



MODUTECH[®]

Movement Technologies

Modular Belt Product Catalog



MODUTECH[®]

Movement Technologies

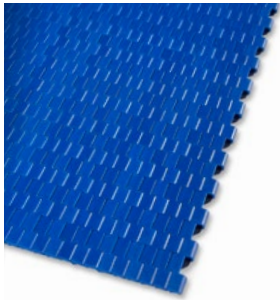

MP80 C 14-15
Micropitch Belt Series

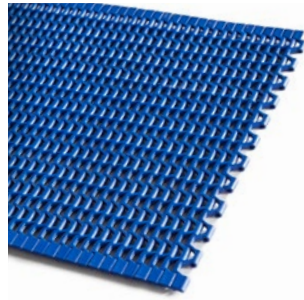

MP80 FG 16-17
Micropitch Belt Series



MP80 NS 18-19
Micropitch Belt Series

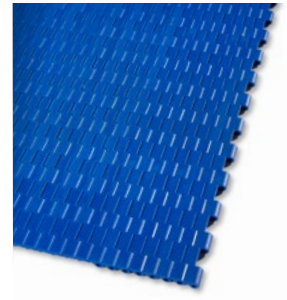

MP80 NP 20-21
Micropitch Belt Series



EC127 C 28-29

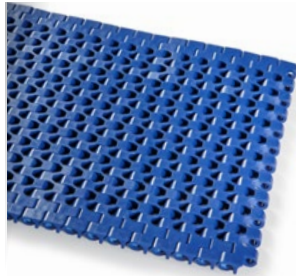

EC127 FG 30-31

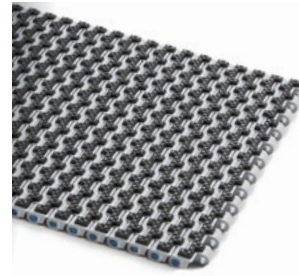

EC127 GT 32-33

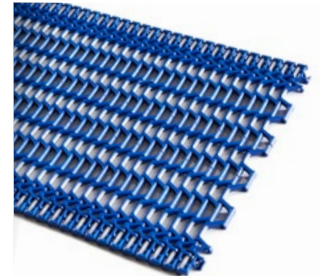

MD127 GAP%50 40-41

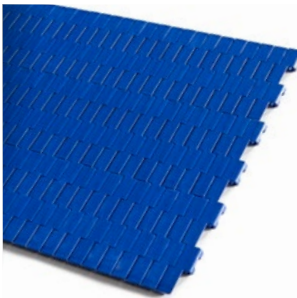

HC127 C 46-47



XP254 CR 52-53
Corrugated & Logistic Belt Series



XP254 FLT CR 54-55
Corrugated & Logistic Belt Series



XP254 C 58-59

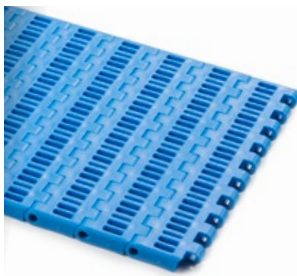

XP254 PR%22 60-61



XP254 FG 62-63

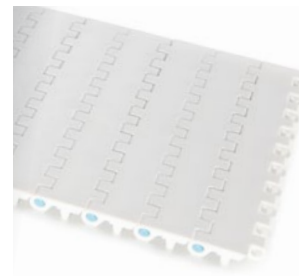

EC254 C 70-71

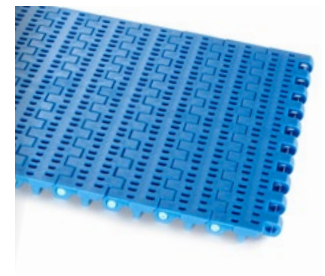

EC254 PR%16 72-73

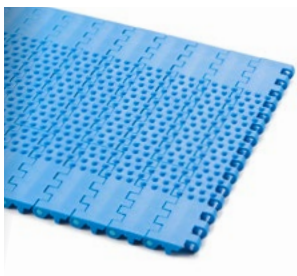

EC254 NT 74-75



MD254 FG 82-83



MD254 C 84-85

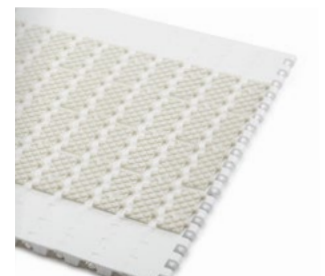

MD254 GT 86-87

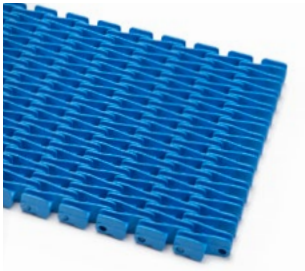

MD254 RR

88-89



MD254 GAP%48

96-97



EC508 C

104-105



EC508 PR%22

106-107



EC508 FG

108-109

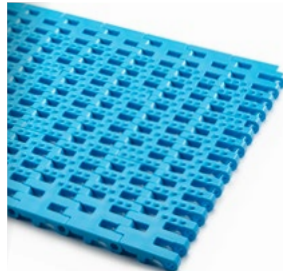

EC508 FG-NT

110-111



EC508 PR%11

112-113



EC508 PR%13

114-115



EC508 DT

116-117

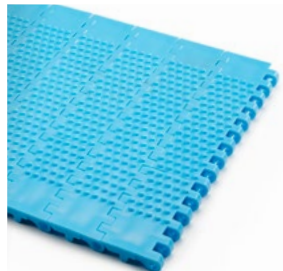

EC508 NT

118-119



MD508 C

126-127



MD508 FG

128-129



MD508 PR%25

130-131



HP508 RR

138-139



HP508 FG

140-141

Battery Belt

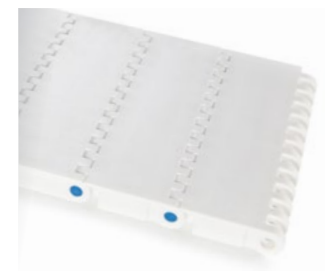

HP508 C

142-143

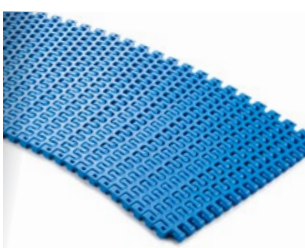

EC254 R

150-151

Radius Belt 2,1

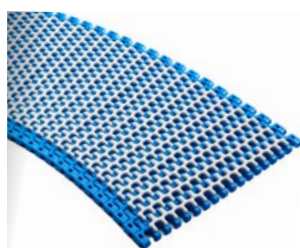

EC254 R-GT

152-153

Radius Belt 2,1 with friction surface



EC254T R

158-159

Tight Radius Belt 1,4

**Engineering
Guide**

166-181

**Declaration
Certificate**

182

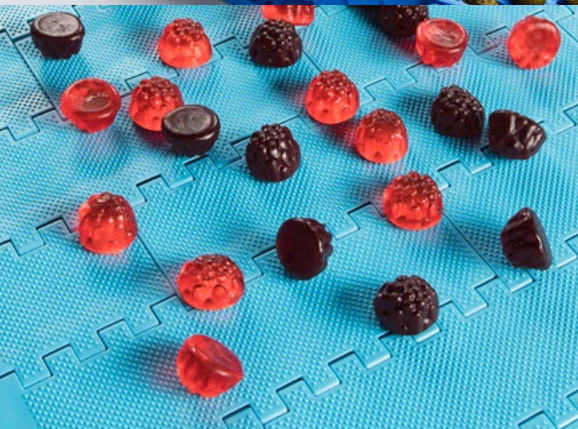

MODUTECH

Movement Technologies

We are rapidly growing. Thanks to the "understanding of excellence" in product and service quality, in the plastic modular belt sector. We export plastic modular belts and accessories (sprockets, flights, sidewalls) produced with high production standards to more than 40 countries, including 5 continents.

We have right partnerships with industrial companies, original equipment manufacturers and distributors in many countries of the world with the strength of our production quality, flexible capability, pre-sales and after-sales service.

We are constantly proving our expertise for food industry. We have FDA and EU approvals that are recognized as quality standards around the world for the safe and hygienic carry of food products.

With our movement technologies, we are carrying your business to the future.

Today and always.



Flexibility for various applications

Modular Belts are more durable, flexible and efficient than traditional conveyor belts because of their material and functional solutions.

Modutech Modular Belts are constructed of plastic modules. They are secured with full-length hinge rods and driven through plastic sprockets which allows customization with a variety of flights, side guards and accessories. In addition, with the advantages of resilience in difficult environments, sterilization, low maintenance and easy installation; modular belts offer high performance even in various applications.

Here are our applications for various industries:

- fruit and vegetable applications
- meat, poultry and seafood applications
- bakery and pasta applications
- beverage applications
- can applications
- corrugated applications



Modutech Modular Belts ensures quality

We rely on standardisation by producing plastic modular belts from design to plastic moulding and assembling at acceptable standards. With the high quality materials combined with ultimate engineering offers us specialization in the production of plastic modular belts. We ensure this quality through complying with FDA and EU regulations. These regulations provides precise manufacturing process and high performance conveyor belts.

High Quality Materials

Best material ensures superior product quality and performance. Because of the material quality, change in temperatures can be easily handled through operations. We offer you standard materials like PP, PE, POM (acetal) and special materials such as detectable, antistatic, flame retardant, extra high temperature, hot water resistant, reinforced and low friction.



Various Industries Need Special Solutions

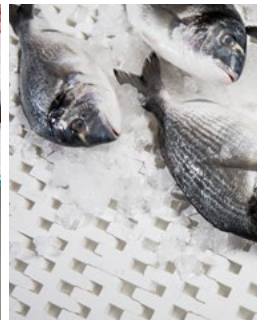

We offer combinable designs, materials and accessories for specific industries. Because, different working environments needs different solutions. Hygiene in case of bacteria retention is the key for food industry. Cleanliness standards are ensured through FDA and EU regulations. During manufacturing process, easy to clean and low maintenance helps you to keep these standards.



MODUTECH

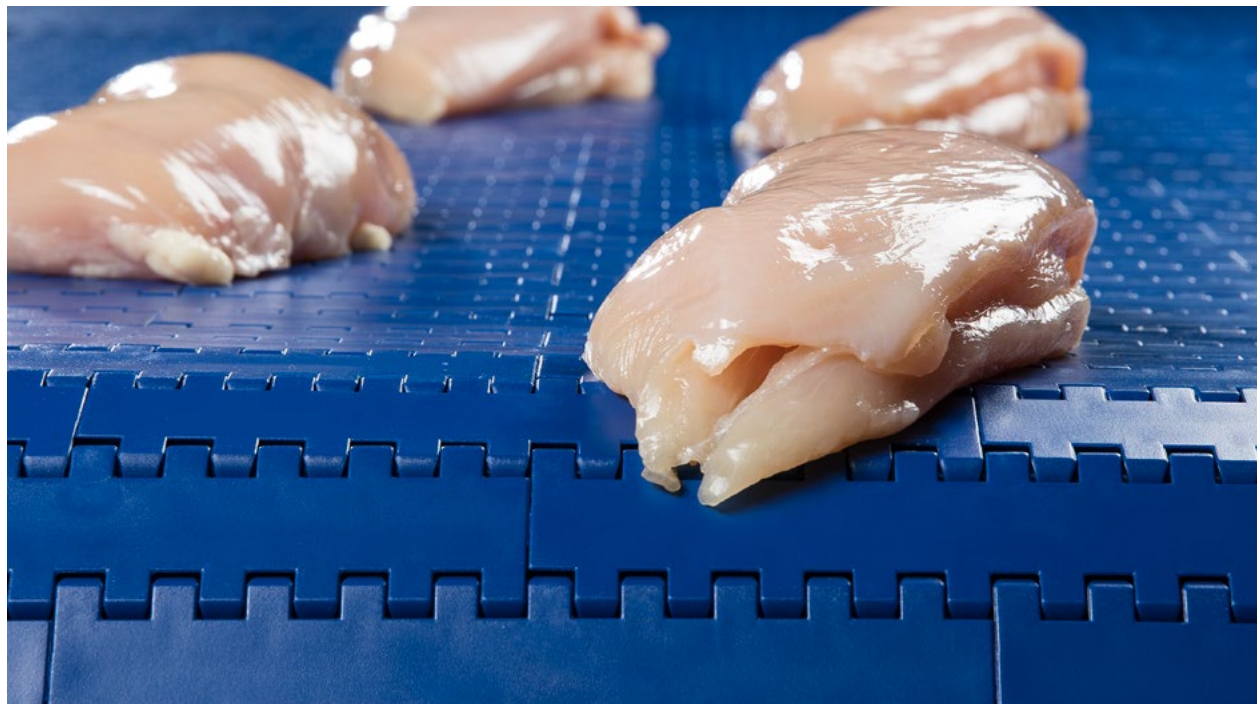

Customer satisfaction based qualified manufacturing



As Modutech Modular Belts, we see the customer satisfaction as one of the most crucial issues. To ensure the customer needs completely, our manufacturing plant which has a 5000 m² closed area and located in an industrial zone is working 7 days and 24 hours. We stock a wide variety of products so that we supply your urgent requests and demands. Delivery on time is also one of the most important matters for us. Through all of this hard work, we always aim to fulfil your requirements efficiently and thus to be your reliable business partner.



MP80

Micro Pitch Modular Belt Series

MP80 C

MP80 FG

MP80 NS (Non-Slip)

MP80 NP (Negative Pyramid)

Sprockets

Engineering Information

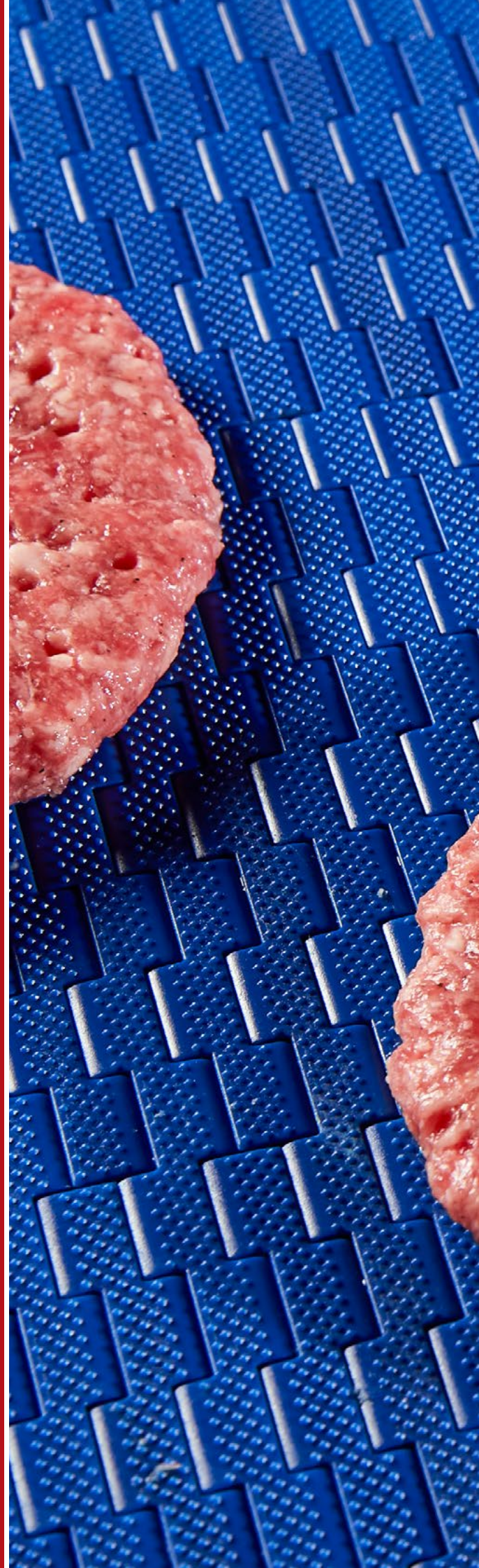





MP80 C

Micro Pitch Modular Belt Series

- ***Bakery Applications***

Row Dough Handling, Divider, Proofer Lines, Laminating Lines

- ***Meat Applications***

Transfer - Crossover Conveyance and Metal Detectors

- ***Seafood Applications***

Grading Lines and Weighing Lines

- ***Fruits and Vegetables Applications***

Control and Sorting Tables

- ***Snack Food Applications***

Cooling Lines

- ***Beverage Applications***

Box Transfer



MP80 C

Pitch:	8 mm / 0.315 inch
Belt Surface:	Close, Smooth Surface
Minimum Width:	101,6 mm / 4 inch
Open Area (%):	0%
Flight:	No
Sidewall:	No
Rod:	Ø3 mm / 0.118 inch
Approved:	FDA and EU
Curve:	No
Color:	Additional colors available
Cleanability:	Good
Belt Thickness:	6 mm / 0.236 inch
Min. Nosebar Diameter:	6 mm / 0.236 inch

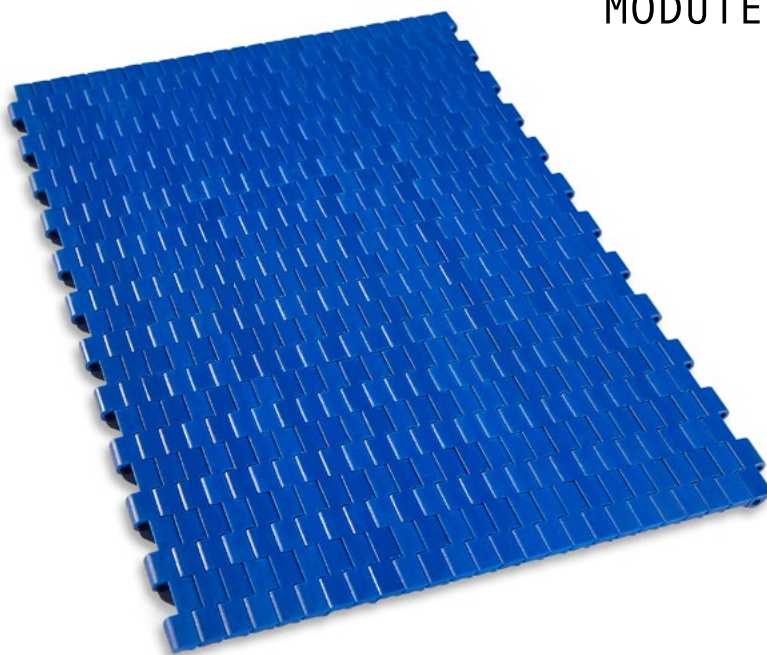

Product Features and Functional Benefits

- Micro pitch series with small transfer gaps for tight transfer.
- Designed to run over 6 mm nosebars or rollers.
- Belt and sprocket design ensures superior load transmission and belt pull capacity.
- Headless pin making it very easy to install and remove the belt for maintenance.

Available Moulded Module Sizes

- 203,2 mm / **8 inch** module
- 101,6 mm / **4 inch** module

MP80 C / Technical Information

BELT / PIN MATERIAL	BELT STRENGTH				TEMPERATURE		BELT WEIGHT
	Straight		Curve		°C / °F (min.)	°C / °F (max.)	
	N/m	lb/ft	N/m	lb/ft			Kg/m ² / lb/ft ²
Acetal / Acetal	2750	188	-	-	-43 / -45.4	+110 / +230	5,3 / 1.09

- Belt strength and temperature values are maximum on the table.

MP80 C / Standard Belt Widths

BELT SERIES	WIDTH (W)				Belt With Tolerance (max.)
	PP-PE		POM		
	mm	inch	mm	inch	
MP80 C	-	-	101,6	4.0	± 1 mm
MP80 C	-	-	203,2	8.0	± 1 mm
MP80 C	-	-	304,8	12.0	± 1 mm
MP80 C	-	-	406,4	16.0	± 1 mm
MP80 C	-	-	508,0	20.0	± 2 mm
MP80 C	-	-	609,6	24.0	± 2 mm
MP80 C	-	-	711,2	28.0	± 2 mm
MP80 C	-	-	812,8	32.0	± 2 mm
MP80 C	-	-	914,4	36.0	± 2 mm

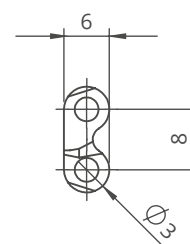
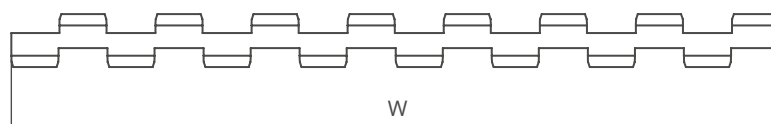

- Standard belt increments 101,6 mm.
 - Non-standard belt increments 25,4 mm.
- Please contact with customer service for precise belt measurements.



MP80 FG

Micro Pitch Modular Belt Series

- **Bakery Applications**

Row Dough Handling, Divider, Proofer Lines, Laminating Lines

- **Meat Applications**

Transfer - Crossover Conveyance and Metal Detectors

- **Seafood Applications**

Grading Lines and Weighing Lines

- **Fruits and Vegetables Applications**

Control and Sorting Tables

- **Snack Food Applications**

Cooling Lines

- **Beverage Applications**

Box Transfer



MP80 FG

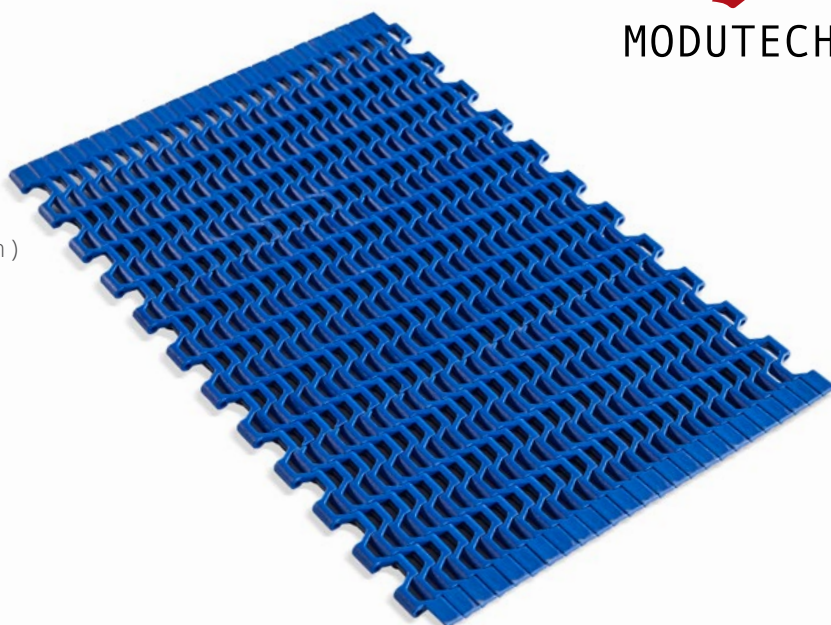

Pitch:	8 mm / 0.315 inch
Belt Surface:	Open, Smooth Surface
Minimum Width:	101,6 mm / 4 inch
Open Area (%):	34%. (Biggest opening 6,5 x 13 mm)
Flight:	No
Sidewall:	No
Rod:	Ø3 mm / 0.118 inch
Approved:	FDA and EU
Curve:	No
Color:	Additional colors available
Cleanability:	Good
Belt Thickness:	6 mm / 0.236 inch
Min. Nosebar Diameter:	6 mm / 0.236 inch

Product Features and Functional Benefits

- Micro pitch series with small transfer gaps for tight transfer.
- Designed to run over nosebars/knife edges or rollers with a radius down to 3mm (**0.12 inch**) allowing, precise transfer of even the smallest products.
- Versatile for conveying, drying and cooling applications.
- Optimal design of sprocket teeth, and belt underside provides superior sprocket engagement, safe belt tracking and favorable cleanability.
- Headless pin making it very easy to install and remove the belt for maintenance.

Available Moulded Module Sizes

- 203,2 mm / **8 inch** module
- 101,6 mm / **4 inch** module

MP80 FG / Technical Information

BELT / PIN MATERIAL	BELT STRENGTH				TEMPERATURE		BELT WEIGHT
	Straight		Curve		°C / °F (min.)	°C / °F (max.)	
	N/m	lb/ft	N/m	lb/ft			Kg/m ² / lb/ft ²
Acetal / Acetal	2650	181	-	-	-43 / -45.4	+110 / +230	4,4 / 0.90

- Belt strength and temperature values are maximum on the table.

MP80 FG / Standard Belt Widths

BELT SERIES	WIDTH (W)				Belt With Tolerance (max.)
	PP-PE		POM		
	mm	inch	mm	inch	
MP80 FG	-	-	101,6	4.0	± 1 mm
MP80 FG	-	-	203,2	8.0	± 1 mm
MP80 FG	-	-	304,8	12.0	± 1 mm
MP80 FG	-	-	406,4	16.0	± 1 mm
MP80 FG	-	-	508,0	20.0	± 2 mm
MP80 FG	-	-	609,6	24.0	± 2 mm
MP80 FG	-	-	711,2	28.0	± 2 mm
MP80 FG	-	-	812,8	32.0	± 2 mm
MP80 FG	-	-	914,4	36.0	± 2 mm

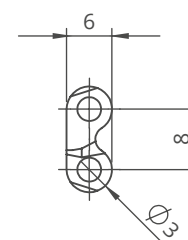
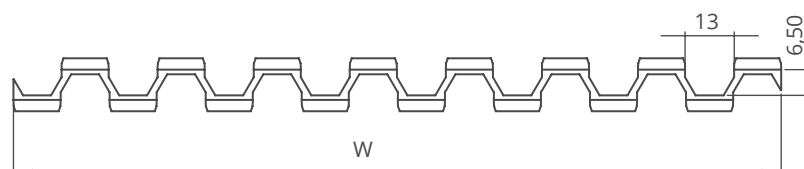

- Standard belt increments 101,6 mm.
 - Non-standard belt increments 25,4 mm.
 Please contact with customer service for precise belt measurements.



MP80 NS

Micro Pitch Modular Belt Series

• Bakery Applications

Row Dough Handling, Divider, Proofer Lines, Laminating Lines

• Meat Applications

Transfer - Crossover Conveyance and Metal Detectors

• Seafood Applications

Grading Lines and Weighing Lines

• Fruits and Vegetables Applications

Control and Sorting Tables

• Snack Food Applications

Cooling Lines

• Beverage Applications

Box Transfer



MP80 NS

Pitch:	8 mm / 0.315 inch
Belt Surface:	Close, Non-Slip Surface
Minimum Width:	101,6 mm / 4 inch
Open Area (%):	0%
Flight:	No
Sidewall:	No
Rod:	Ø3 mm / 0.118 inch
Approved:	FDA and EU
Curve:	No
Color:	Additional colors available
Cleanability:	Good
Belt Thickness:	6,4 mm / 0.252 inch
Min. Nosebar Diameter:	6 mm / 0.236 inch

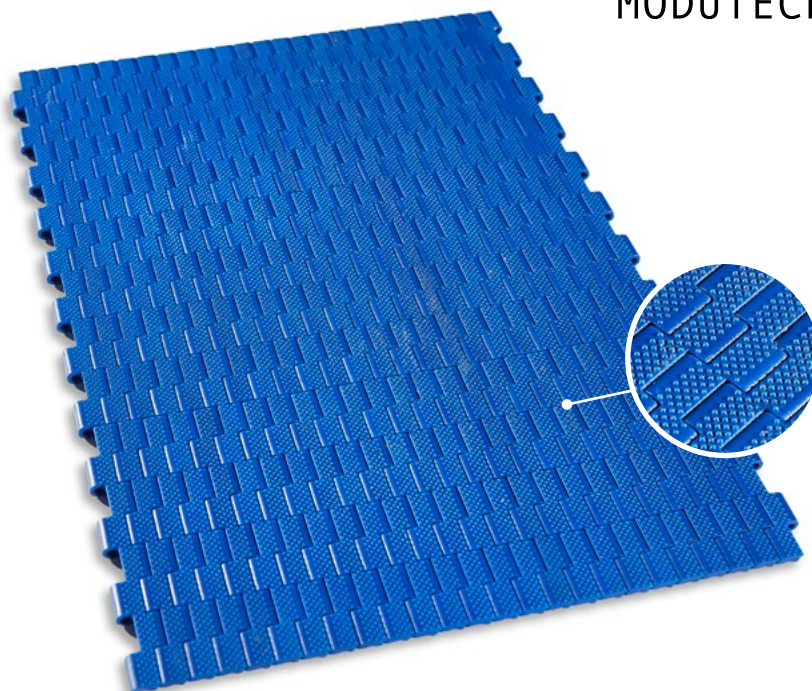

Product Features and Functional Benefits

- Closed surface and pointed studs, cone top surface pattern for superior grip
- Micro pitch series with small transfer gaps for tight transfer.
- Designed to run over nosebars/knife edges or rollers with a radius down to 3mm (**0.12 inch**) allowing, precise transfer of even the smallest products.
- Optimal design of sprocket teeth, and belt underside provides superior sprocket engagement, safe belt tracking and favorable cleanability.
- Headless pin making it very easy to install and remove the belt for maintenance.

Available Moulded Module Sizes

- 203,2 mm / **8 inch** module
- 101,6 mm / **4 inch** module

MP80 NS / Technical Information

BELT / PIN MATERIAL	BELT STRENGTH				TEMPERATURE		BELT WEIGHT
	Straight		Curve		°C / °F (min.)	°C / °F (max.)	Kg/m² / lb/ft²
	N/m	lb/ft	N/m	lb/ft			
Acetal / Acetal	2750	188	-	-	-43 / -45.4	+110 / +230	5,3 / 1.09

- Belt strength and temperature values are maximum on the table.

MP80 NS / Standard Belt Widths

BELT SERIES	WIDTH (W)				Belt With Tolerance (max.)
	PP-PE		POM		
	mm	inch	mm	inch	
MP80 NS	-	-	101,6	4.0	± 1 mm
MP80 NS	-	-	203,2	8.0	± 1 mm
MP80 NS	-	-	304,8	12.0	± 1 mm
MP80 NS	-	-	406,4	16.0	± 1 mm
MP80 NS	-	-	508,0	20.0	± 2 mm
MP80 NS	-	-	609,6	24.0	± 2 mm
MP80 NS	-	-	711,2	28.0	± 2 mm
MP80 NS	-	-	812,8	32.0	± 2 mm
MP80 NS	-	-	914,4	36.0	± 2 mm

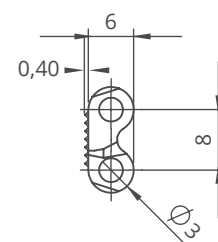
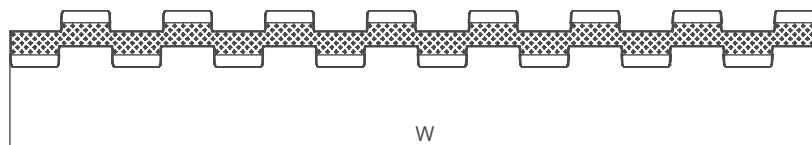

- Standard belt increments 101,6 mm.
 - Non-standard belt increments 25,4 mm.
- Please contact with customer service for precise belt measurements.



MP80 NP

Micro Pitch Modular Belt Series

• Bakery Applications

Row Dough Handling, Divider, Proofer Lines, Laminating Lines

• Meat Applications

Transfer - Crossover Conveyance and Metal Detectors

• Seafood Applications

Grading Lines and Weighing Lines

• Fruits and Vegetables Applications

Control and Sorting Tables

• Snack Food Applications

Cooling Lines

• Beverage Applications

Box Transfer



MODUTECH

MP80 NP

Pitch:	8 mm / 0.315 inch
Belt Surface:	Close, Negative Pyramid Surface
Minimum Width:	101,6 mm / 4 inch
Open Area (%):	0%
Flight:	No
Sidewall:	No
Rod:	Ø3 mm / 0.118 inch
Approved:	FDA and EU
Curve:	No
Color:	Additional colors available
Cleanability:	Good
Belt Thickness:	6 mm / 0.236 inch
Min. Nosebar Diameter:	6 mm / 0.236 inch

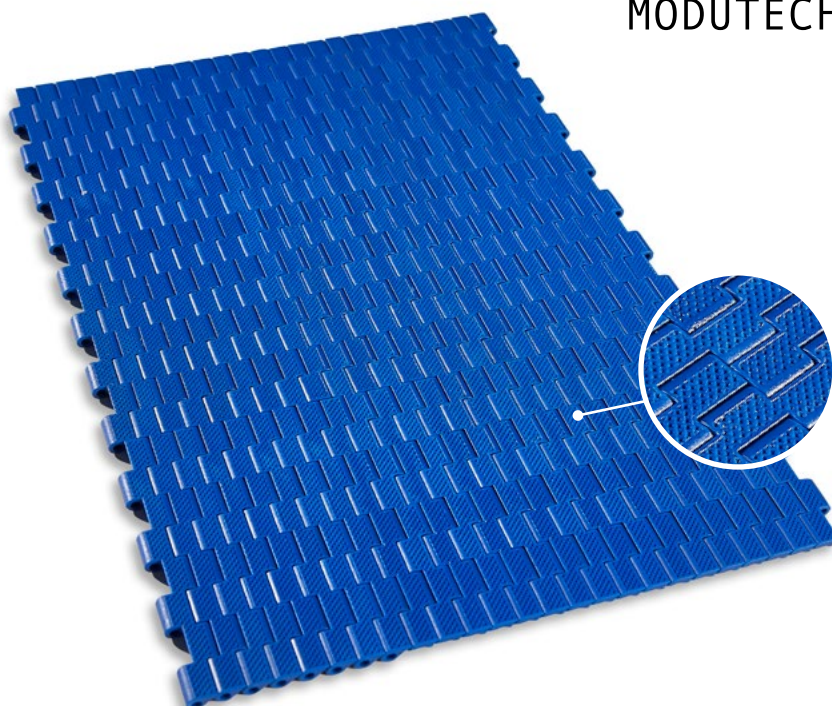

Product Features and Functional Benefits

- Closed surface with inverted pyramid pattern.
- Provides superb release characteristics when conveying wet or sticky products
- Micropitch series with small transfer gaps for tight transfer.
- Designed to run over nosebars/knife edges or rollers with a radius down to 3mm (**0.12 inch**) allowing, precise transfer of even the smallest products.
- Optimal design of sprocket teeth, and belt underside provides superior sprocket engagement, safe belt tracking and favorable cleanability.
- Headless pin making it very easy to install and remove the belt for maintenance.

Available Moulded Module Sizes

- 203,2 mm / **8 inch** module
- 101,6 mm / **4 inch** module

MP80 NP / Technical Information

BELT / PIN MATERIAL	BELT STRENGTH				TEMPERATURE		BELT WEIGHT
	Straight		Curve		°C / °F (min.)	°C / °F (max.)	Kg/m ² / lb/ft ²
	N/m	lb/ft	N/m	lb/ft			
Acetal / Acetal	2750	188	-	-	-43 / -45.4	+110 / +230	5,3 / 1.09

- Belt strength and temperature values are maximum on the table.

MP80 NP / Standard Belt Widths

BELT SERIES	WIDTH (W)				Belt With Tolerance (max.)
	PP-PE		POM		
	mm	inch	mm	inch	
MP80 NP	-	-	101,6	4.0	± 1 mm
MP80 NP	-	-	203,2	8.0	± 1 mm
MP80 NP	-	-	304,8	12.0	± 1 mm
MP80 NP	-	-	406,4	16.0	± 1 mm
MP80 NP	-	-	508,0	20.0	± 2 mm
MP80 NP	-	-	609,6	24.0	± 2 mm
MP80 NP	-	-	711,2	28.0	± 2 mm
MP80 NP	-	-	812,8	32.0	± 2 mm
MP80 NP	-	-	914,4	36.0	± 2 mm

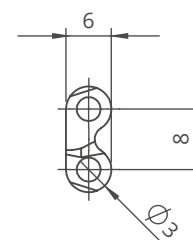
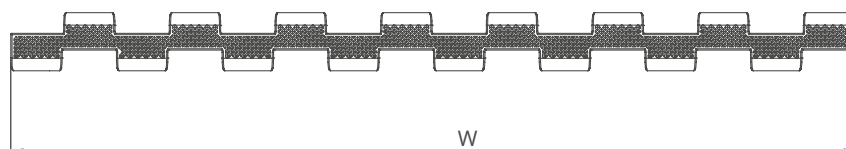

- Standard belt increments 101,6 mm.
 - Non-standard belt increments 25,4 mm.
 Please contact with customer service for precise belt measurements.

Micro Pitch Modular Belt Series

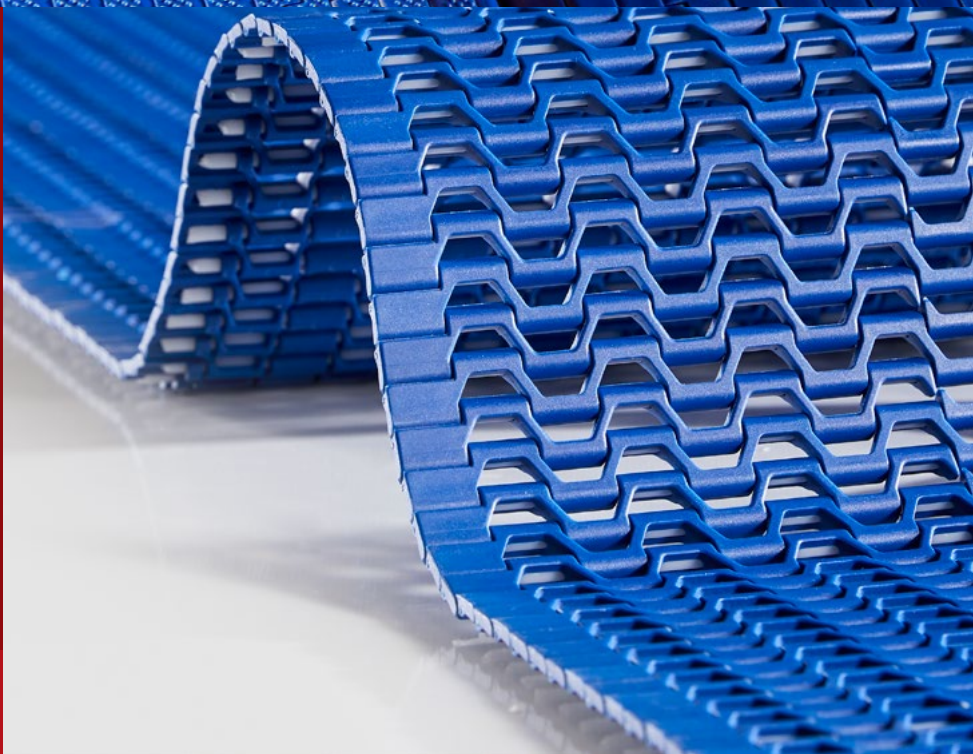



MP80 (Micro Pitch Series)

Technical Specifications



Z36

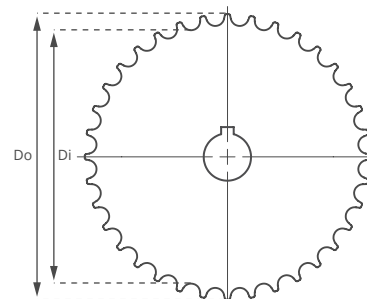
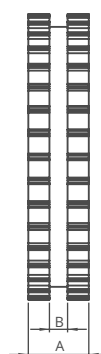
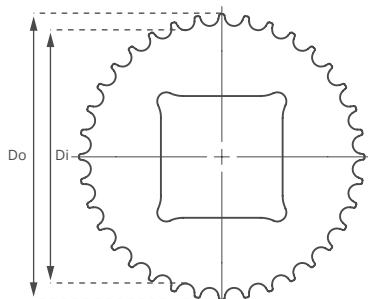

MP80 Micro Pitch Series / Machined Sprockets Dimensions

NO.TEETH	Di mm/inch	Do mm/inch	B mm/inch	A mm/inch	Square Bore (Q) mm/inch	Round Bore (R) mm/inch	PRODUCT CODE	
							Square Type (Q)	Round Type (R)
Z18	40,9 / 1.61	48,0 / 1.89	6 / 0.23	20 / 0.78	20 / 0.78	25 / 1	MP80SQZ18	MP80SRZ18
Z24	56,4 / 2.22	63,7 / 2.51	6 / 0.23	20 / 0.78	25 / 1	25-30 / 1-1.25	MP80SQZ24	MP80SRZ24
Z36	87,5 / 3.44	94,9 / 3.74	6 / 0.23	20 / 0.78	40 / 1.57	25-30 / 1-1.25	MP80SQZ36	MP80SRZ36

*All required sprockets produced by CNC.

*Other sprockets and hub sizes are manufactured up to request.

*POM (Acetal) and PA (Polyamide) sprockets raw material is available on request.

***Machined Split Sprockets are available for each size.**



Precise transfer even the smallest products!

Micropitch belt series are suitable to run 6 mm nosebar roller.



MP80 Series *Engineering Information*

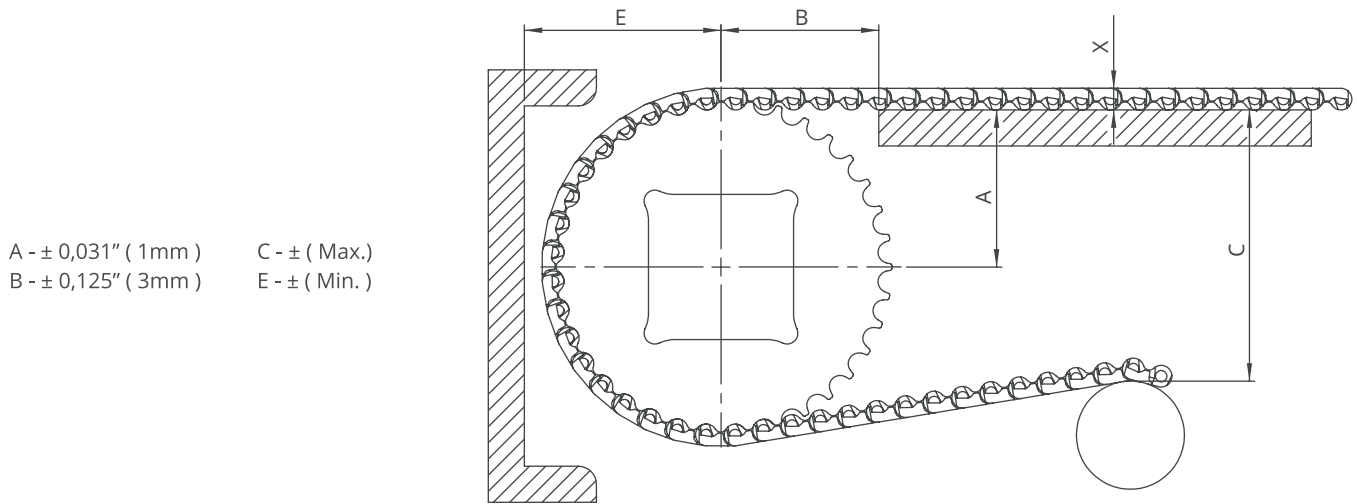

A - ± 0,031" (1mm) C - ± (Max.)
 B - ± 0,125" (3mm) E - ± (Min.)

MP80 Series / Conveyor Frame Dimensions

Sprockets Description		A		B		C		E		X		
Pitch Diameter		Range (Bottom to Top)		Inch	mm	Inch	mm	Inch	mm	Inch	mm	
Inch	mm	Inch	mm									Inch
MP80 C, MP80 FG, MP80 NP, MP80 NS												
1.85	47,0	18	0.81	20,5	1.18	30,0	1.12	28,5	1.24	31,5	0.24	6,0
1.95	49,5	24	1.11	28,3	1.38	35,0	1.73	44,0	1.55	39,3	0.24	6,0
3.68	93,5	36	1.72	43,8	1.77	45,0	2.95	75,0	2.16	54,8	0.24	6,0

MP80 Series / Slider Support System For Straight Running Belts

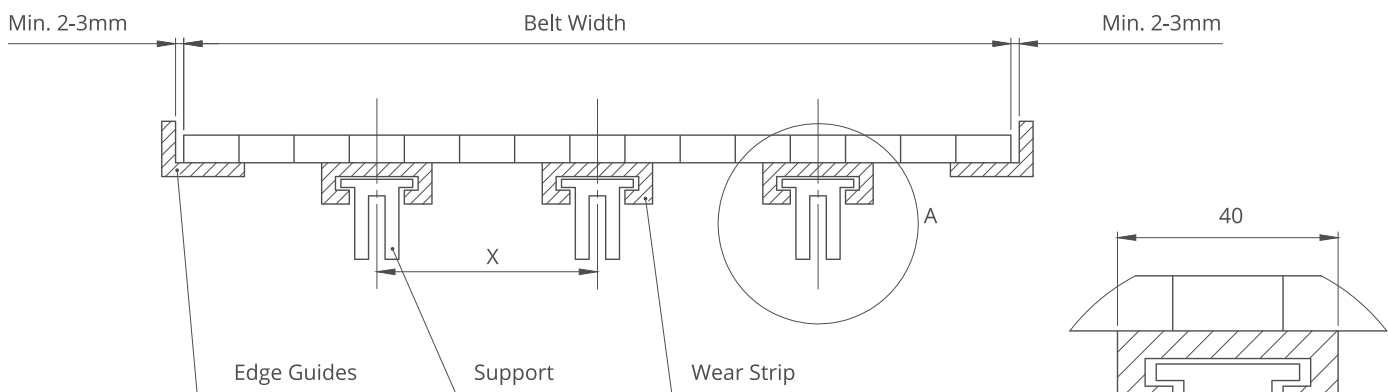

Note: The max. distances between the wear strips have to be (X) ;

125 mm for 2" belts
 80 mm for 1" / 0.5" belts

Detail A
 Scale 1:1

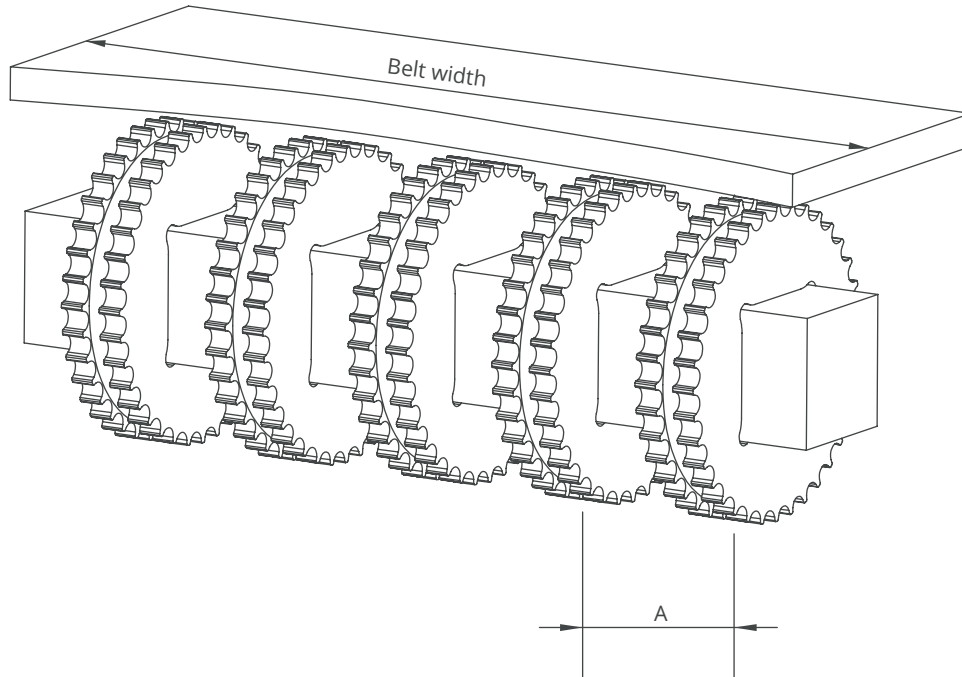

MP80 Series / Sprockets Arrangement

Standard Belt Width		Number of sprockets per shaft		A (mm/inch)	
mm	inch	Drive Shaft	Return Shaft	Min.	Max.
101,6	4.0	2	2	50/2	100/4
203,2	8.0	3	2	50/2	100/4
304,8	12.0	4	3	50/2	100/4
406,4	16.0	5	3	50/2	100/4
508,0	20.0	6	4	50/2	100/4
609,6	24.0	7	5	50/2	100/4
711,2	28.0	8	6	50/2	100/4
812,8	32.0	9	7	50/2	100/4
914,4	36.0	10	8	50/2	100/4
1016,0	40.0	11	9	50/2	100/4
1117,6	44.0	12	9	50/2	100/4
1219,2	48.0	13	10	50/2	100/4
1320,8	52.0	14	11	50/2	100/4
1422,4	56.0	14	11	50/2	100/4
1524,0	60.0	15	12	50/2	100/4
1625,6	64.0	16	12	50/2	100/4

EC127

Modular Belt Series

EC127 C

EC127 FG

EC127 GT / Friction Top

Sprockets & Accessories

Engineering Information







EC127 C

Modular Belt Series

- **Bakery Applications**

Row Dough Handling, Divider, Proofer Lines, Laminating Lines

- **Meat Applications**

Transfer - Crossover Conveyance and Metal Detectors

- **Seafood Applications**

Grading Lines and Weighing Lines

- **Beverage Applications**

Depalletizers, Accumulation Tables and Acceleration Lines

- **Fruits and Vegetables Applications**

Control and Sorting Tables

- **Can Manufacturing Applications**

Including Palletizers, Mass Handling and Accumulation Tables

- **Tire Manufacturing Applications**

*Scalling, Marking, Sciver Cementing, Water Blow - Off,
Tire Transport Horizontal*

- **Corrugated Applications**

Down Stackers, Corrugator Take Off, Transfer Car



EC127 C

Pitch:	12,7 mm / 0.5 inch
Belt Surface:	Close, Smooth Surface
Minimum Width:	50 mm / 1.97 inch
Open Area (%):	0%
Flight:	Yes (T25, T50)
Sidewall:	No
Rod:	Ø4,7 mm / 0.185 inch - Self Lock
Approved:	FDA and EU
Curve:	No
Color:	Additional colors available
Cleanability:	Good
Belt Thickness:	10 mm / 0.394 inch

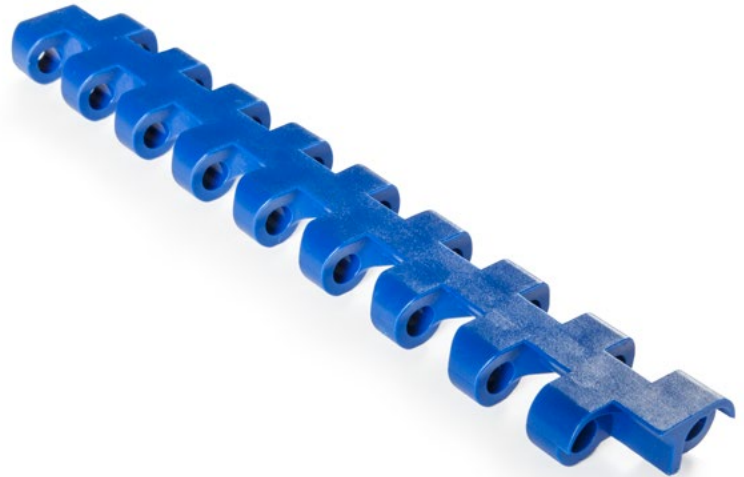

Product Features and Functional Benefits

- Less vibration in high speed and nosebar applicaitons.
- Wear resistance in high speed applications with tight transfer.
- Unique sprocket engagement reduces pulsation.
- Tight transfer applications.
- Tight transfer and high speed conveyors.

Available Moulded Module Sizes

- 150 mm / **5.90 inch** module
- 100 mm / **3.94 inch** module
- 50 mm / **1.97 inch** module

EC127 C / Technical Information

BELT MATERIAL	BELT STRENGTH				TEMPERATURE		BELT WEIGHT Kg/m ² / lb/ft ²
	Straight		Curve		°C / °F (min.)	°C/°F (max.)	
	N/m	lb/ft	N/m	lb/ft			
Polypropylene	12100	829	-	-	+5 / +41	+90 / +194	5,8 / 1.20
Polyethylene	6600	452	-	-	-73 / -99.4	+66 / +150.8	6,2 / 1.27
Acetal	19800	1356	-	-	-43 / -45.4	+110 / +230	8,7 / 1.78

- Belt strength and temperature values are maximum on the table.

EC127 C / Standard Belt Widths

BELT SERIES	WIDTH (W)				Belt With Tolerance (max.)
	PP-PE		POM		
	mm	inch	mm	inch	
EC127 C	150,0	5.90	150,0	5.90	± 1 mm
EC127 C	200,0	7.87	200,0	7.87	± 1 mm
EC127 C	250,0	9.84	250,0	9.84	± 2 mm
EC127 C	300,0	11.81	300,0	11.81	± 2 mm
EC127 C	350,0	13.77	350,0	13.77	± 2 mm
EC127 C	400,0	15.75	400,0	15.75	± 2 mm
EC127 C	450,0	17.71	450,0	17.71	± 2 mm
EC127 C	500,0	19.69	500,0	19.69	± 2 mm
EC127 C	550,0	21.65	550,0	21.65	± 2 mm
EC127 C	600,0	23.62	600,0	23.62	± 3 mm
EC127 C	650,0	25.60	650,0	25.60	± 3 mm
EC127 C	700,0	27.56	700,0	27.56	± 3 mm
EC127 C	750,0	29.50	750,0	29.50	± 3 mm
EC127 C	800,0	31.50	800,0	31.50	± 3 mm
EC127 C	850,0	33.46	850,0	33.46	± 4 mm
EC127 C	900,0	35.43	900,0	35.43	± 4 mm

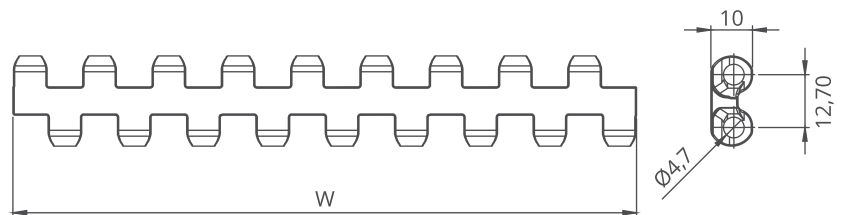

- Standard belt increments 50 mm.
- Non-standard belt increments 16,6 mm.
- Please contact with customer service for precise belt measurements.



EC127 FG

Modular Belt Series

- Bakery Applications

Divider, Oven Infeed - Outfeed, Cooling Lines, Coating Lines, Glazing Lines

- Poultry Applications

Breeding Lines and Grading Lines, Weighing Lines

- Seafood Applications

Breeding Lines, Grading Lines and Weighing Lines

- Snack Food Applications

Cooling Lines

- Fruits and Vegetables Applications

Draining, Sterilization, Conveyance

- Packaging Applications

Check Weighers, Filling, Palletizing - Depalletizing, Box Transfer



EC127 FG

Pitch:	12,7 mm / 0.5 inch
Belt Surface:	Open, Smooth Surface
Minimum Width:	50 mm / 1.97 inch
Open Area (%):	20%. (Biggest opening 3 x 6 mm)
Flight:	Yes (T25, T50)
Sidewall:	No
Rod:	Ø4,7 mm / 0.185 inch - Self Lock
Approved:	FDA and EU
Curve:	No
Color:	Additional colors available
Cleanability:	Excellent
Belt Thickness:	10 mm / 0.394 inch



Product Features and Functional Benefits

- Belt provides optimal open area for drainage and airflow.
- Less friction and product contact for easy cooking, cooling and freezing of products.
- Reduced dirt and oxide build due to self cleaning surface.

Available Moulded Module Sizes

- 150 mm / **5.90 inch** module
- 100 mm / **3.94 inch** module
- 50 mm / **1.97 inch** module

EC127 FG / Technical Information

BELT MATERIAL	BELT STRENGTH				TEMPERATURE		BELT WEIGHT
	Straight		Curve		°C / °F (min.)	°C/°F (max.)	Kg/m ² / lb/ft ²
	N/m	lb/ft	N/m	lb/ft			
Polypropylene	12100	825	-	-	+5 / +41	+90 / +194	5,2 / 1.07
Polyethylene	6600	452	-	-	-73 / -99.4	+66 / +150.8	5,4 / 1.11
Acetal	19800	1356	-	-	-43 / -45.4	+110 / +230	7,2 / 1.48

- Belt strength and temperature values are maximum on the table.

EC127 FG / Standard Belt Widths

BELT SERIES	WIDTH (W)				Belt With Tolerance (max.)
	PP-PE		POM		
	mm	inch	mm	inch	
EC127 FG	150,0	5.90	150,0	5.90	± 1 mm
EC127 FG	200,0	7.87	200,0	7.87	± 1 mm
EC127 FG	250,0	9.84	250,0	9.84	± 2 mm
EC127 FG	300,0	11.81	300,0	11.81	± 2 mm
EC127 FG	350,0	13.77	350,0	13.77	± 2 mm
EC127 FG	400,0	15.75	400,0	15.75	± 2 mm
EC127 FG	450,0	17.71	450,0	17.71	± 2 mm
EC127 FG	500,0	19.69	500,0	19.69	± 2 mm
EC127 FG	550,0	21.65	550,0	21.65	± 2 mm
EC127 FG	600,0	23.62	600,0	23.62	± 3 mm
EC127 FG	650,0	25.60	650,0	25.60	± 3 mm
EC127 FG	700,0	27.56	700,0	27.56	± 3 mm
EC127 FG	750,0	29.50	750,0	29.50	± 3 mm
EC127 FG	800,0	31.50	800,0	31.50	± 3 mm
EC127 FG	850,0	33.46	850,0	33.46	± 4 mm
EC127 FG	900,0	35.43	900,0	35.43	± 4 mm

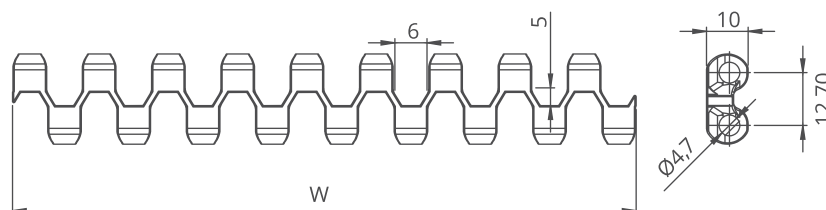

- Standard belt increments 50 mm.
- Non-standard belt increments 16,6 mm.
- Please contact with customer service for precise belt measurements.

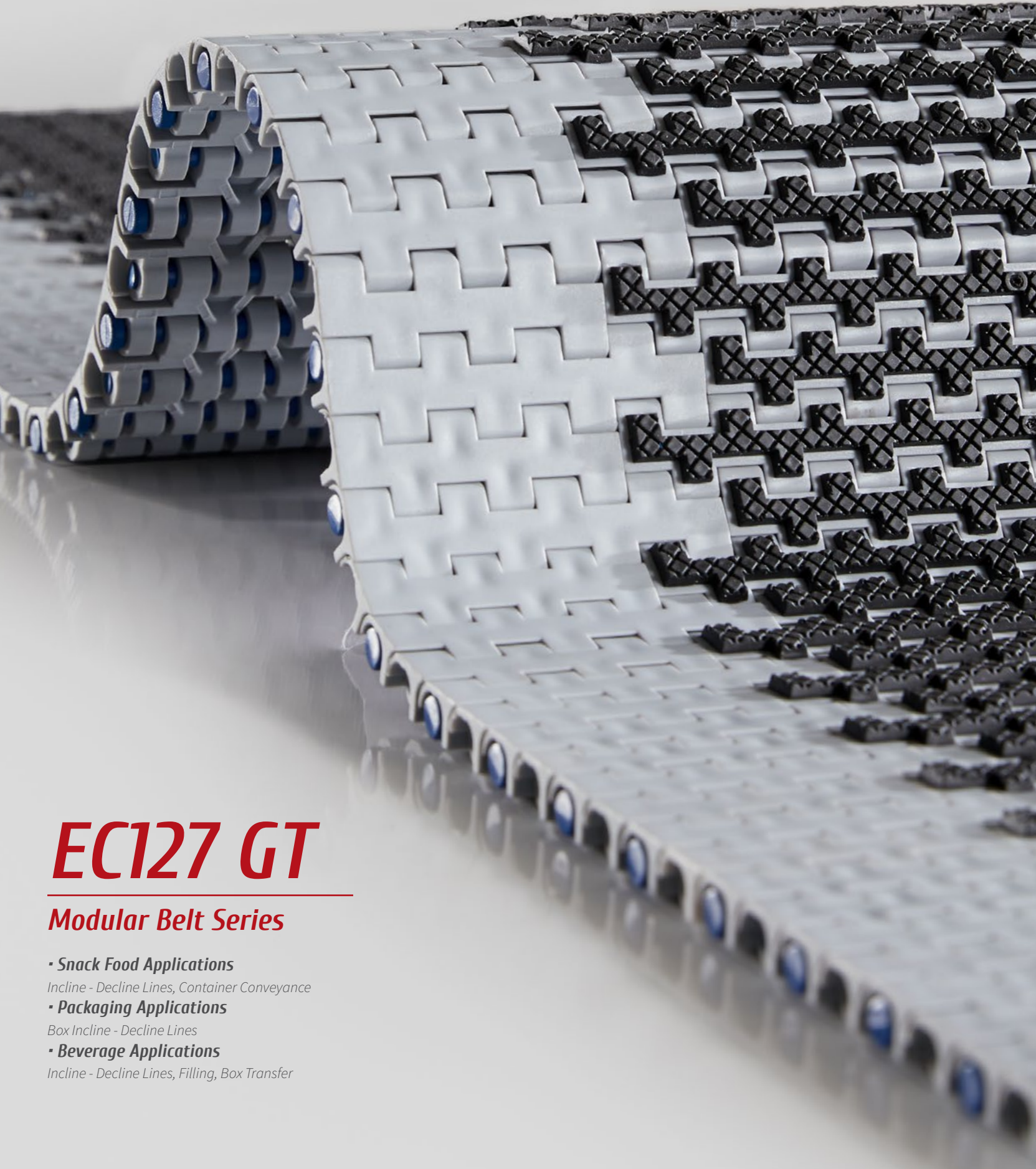

EC127 GT

Modular Belt Series

- **Snack Food Applications**

Incline - Decline Lines, Container Conveyance

- **Packaging Applications**

Box Incline - Decline Lines

- **Beverage Applications**

Incline - Decline Lines, Filling, Box Transfer



EC127 GT



Pitch:	12,7 mm / 0.5 inch
Belt Surface:	Close, Friction Surface
Minimum Width:	150 mm / 5.90 inch
Open Area (%):	0%
Flight:	Yes (T25, T50)
Sidewall:	No
Rod:	Ø4,7 mm / 0.185 inch - Self Lock
Approved:	FDA and EU
Curve:	No
Color:	Additional colors available
Cleanability:	Excellent
Belt Thickness:	12,5 mm / 0.49 inch

Product Features and Functional Benefits

- Unique rubber top eliminates wear and increases friction in incline-decline applications.
- Minimum nosebar diameter 18 mm.
- Tight transfer applications.

Available Moulded Module Sizes

- 150 mm / **5.90 inch** module

EC127 GT / Technical Information

BELT MATERIAL	BELT STRENGTH				TEMPERATURE		BELT WEIGHT
	Straight		Curve		°C / °F (min.)	°C/°F (max.)	Kg/m ² / lb/ft ²
	N/m	lb/ft	N/m	lb/ft			
Polypropylene	9900	679	-	-	+5 / +41	+90 / +194	6,5 / 1.33
Polyethylene	-	-	-	-	-	-	-
Acetal	-	-	-	-	-	-	-

- Belt strength and temperature values are maximum on the table.

EC127 GT / Standard Belt Widths

BELT SERIES	WIDTH (W)				Belt With Tolerance (max.)
	PP		POM		
	mm	inch	mm	inch	
EC127 GT	150,0	5.90	-	-	± 1 mm
EC127 GT	200,0	7.87	-	-	± 1 mm
EC127 GT	250,0	9.84	-	-	± 2 mm
EC127 GT	300,0	11.81	-	-	± 2 mm
EC127 GT	350,0	13.77	-	-	± 2 mm
EC127 GT	400,0	15.75	-	-	± 2 mm
EC127 GT	450,0	17.71	-	-	± 2 mm
EC127 GT	500,0	19.69	-	-	± 2 mm
EC127 GT	550,0	21.65	-	-	± 2 mm
EC127 GT	600,0	23.62	-	-	± 3 mm
EC127 GT	650,0	25.60	-	-	± 3 mm
EC127 GT	700,0	27.56	-	-	± 3 mm
EC127 GT	750,0	29.50	-	-	± 3 mm
EC127 GT	800,0	31.50	-	-	± 3 mm
EC127 GT	850,0	33.46	-	-	± 4 mm
EC127 GT	900,0	35.43	-	-	± 4 mm

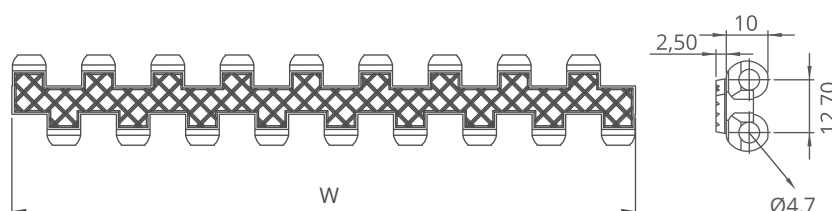

- Standard belt increments 50 mm.
- Non-standard belt increments 16,6 mm.
- Please contact with customer service for precise belt measurements.

EC127 Series Sprockets and Technical Specifications



Z24



Z24

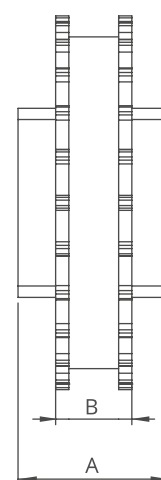
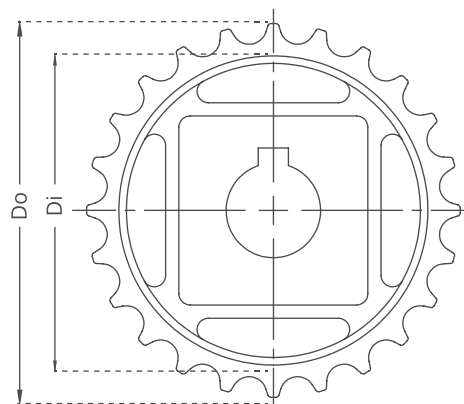
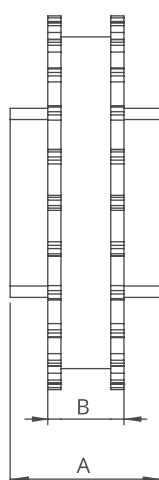
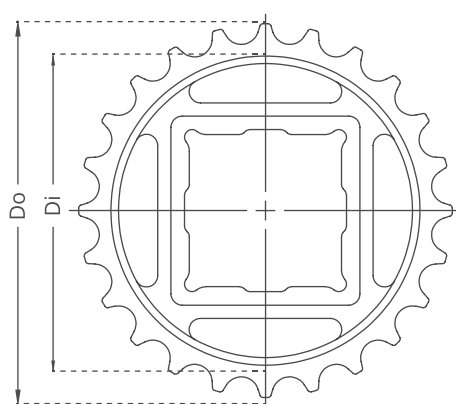

EC127 Series / Standard Moulded Sprockets Dimensions

NO. TEETH	Di mm/inch	Do mm/inch	B mm/inch	A mm/inch	Square Bore (Q) mm/inch	Round Bore (R) mm/inch	PRODUCT CODE	
							Square Type (Q)	Round Type (R)
Z19	68,5 / 2.69	78,0 / 2.54	20 / 0.79	40 / 1.57	25-40 / 1-1.5	25-30 / 1-1.25	EC127SQZ19*PA	EC127SRZ19*PA
Z24	88,7 / 3.49	98,8 / 3.89	20 / 0.79	40 / 1.57	25-40 / 1-1.5	25-30 / 1-1.25	EC127SQZ24*PA	EC127SRZ24*PA
Z28	105,0 / 4.13	115,2 / 4.53	20 / 0.79	40 / 1.57	25-40 / 1-1.5	25-30 / 1-1.25	EC127SQZ28*PA	EC127SRZ28*PA
Z30	113,0 / 4.44	123,3 / 4.85	20 / 0.79	40 / 1.57	25-40 / 1-1.5	25-30 / 1-1.25	EC127SQZ30*PA	EC127SRZ30*PA
Z36	137,5 / 5.41	148,0 / 5.82	20 / 0.79	40 / 1.57	25-40 / 1-1.5	25-30 / 1-1.25	EC127SQZ36*PA	EC127SRZ36*PA

*Other sprockets and hub sizes are manufactured up to request.

*POM (Acetal) and PP (Polypropylene) sprockets raw material is available on request.

***Machined Split Sprockets are available for each size.**



Clamp



Machined Split Sprocket



Moulded Sprocket

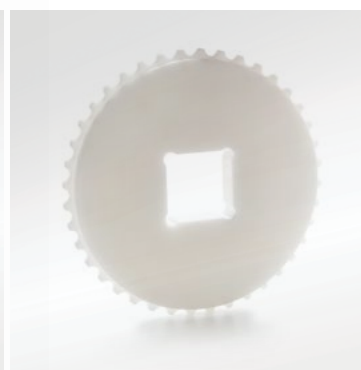

Machined Sprocket

EC127 Series *Accessories and Technical Specifications*



EC127 Series / Flight Dimensions

EC127 Series / Flights				
PRODUCT CODE	Flight Height (mm/ inch)	Flight Width (mm/ inch)	PRODUCT CODE	Sidewall Height (mm/ inch)
EC127T25	25 / 1	150 / 5.90	-	-
EC127T50	50 / 2	150 / 5.90	-	-

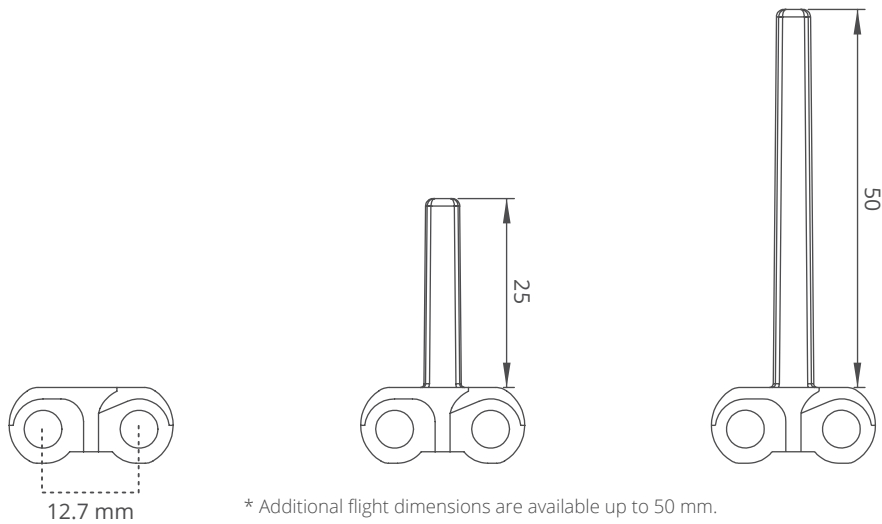

* Additional flight dimensions are available up to 50 mm.

EC127 Series / Flight Technical Specifications

Possible Flight Indents for EC127 Series	Z	
	mm	inch
Standard, module cutting	33,3	1.31
Standard, no module cutting	50,0	1.97
Standard, module cutting	66,6	2.62
Standard, module cutting	83,3	3.28
Standard, no module cutting	100,0	3.94

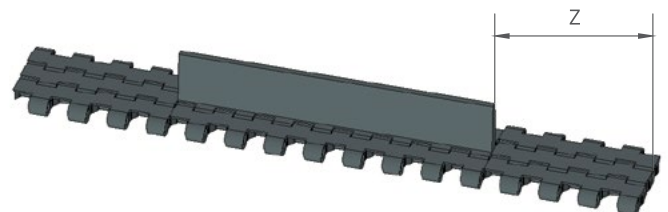

*Non-standard flight indent is on request.

EC127 Series *Engineering Information*

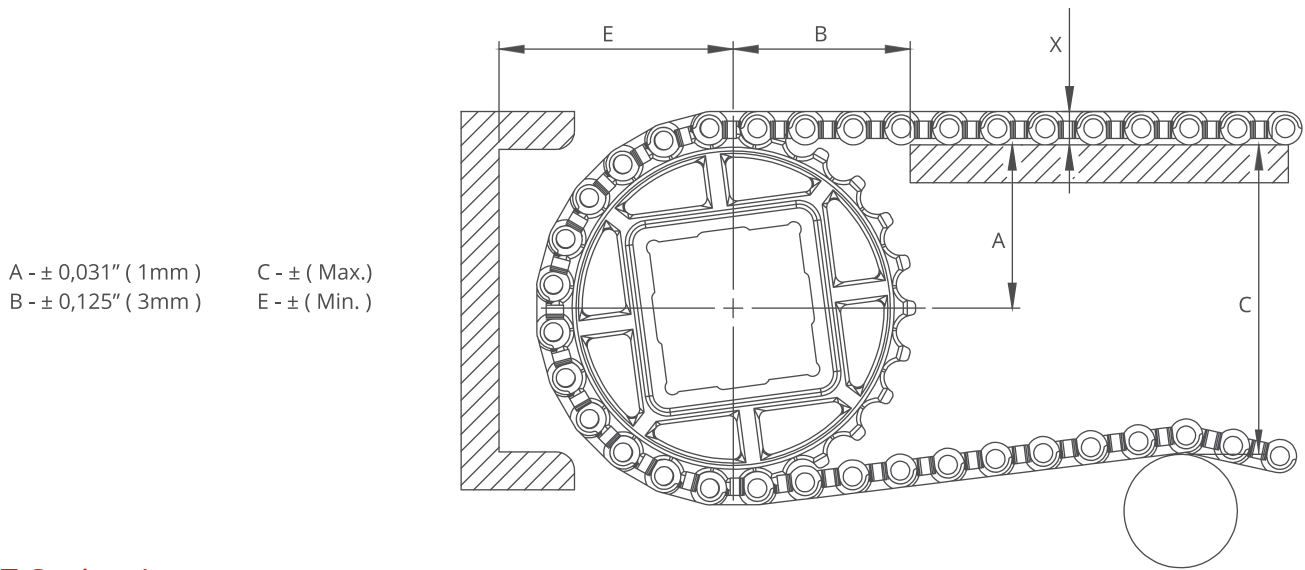

A - ± 0,031" (1mm) C - ± (Max.)
 B - ± 0,125" (3mm) E - ± (Min.)

EC127 Series / Conveyor Frame Dimensions

Sprockets Description			A		B		C		E		X	
Pitch Diameter		No.Teeth	Range (Bottom to Top)		inch	mm	inch	mm	inch	mm	inch	mm
inch	mm		inch	mm								
EC127 C, EC127 FG												
2.89	73,4	19	1.36	34,5	1.67	42,5	2.83	72,0	2.09	53,0	0.39	10,0
3.69	93,8	24	1.73	44,0	1.89	48,0	3.23	82,0	2.48	63,0	0.39	10,0
4.33	110,1	28	2.07	52,5	2.05	52,0	3.86	98,0	2.80	71,0	0.39	10,0
4.66	118,3	30	2.24	57,0	2.13	54,0	4.02	102,0	2.95	75,0	0.39	10,0
5.62	142,7	36	2.72	69,0	2.35	59,8	4.96	126,0	3.43	87,0	0.39	10,0
EC127 GT												
2.89	73,4	19	1.46	37,0	1.67	42,5	2.83	72,0	2.19	55,5	0.49	12,5
3.69	93,8	24	1.83	46,5	1.89	48,0	3.23	82,0	2.58	65,5	0.49	12,5
4.33	110,1	28	2.17	55,0	2.05	52,0	3.86	98,0	2.89	73,5	0.49	12,5
4.66	118,3	30	2.34	59,5	2.13	54,0	4.02	102,0	3.05	77,5	0.49	12,5
5.62	142,7	36	2.81	71,5	2.35	59,8	4.96	126,0	3.52	89,5	0.49	12,5

EC127 Series / Slider Support System For Straight Running Belts

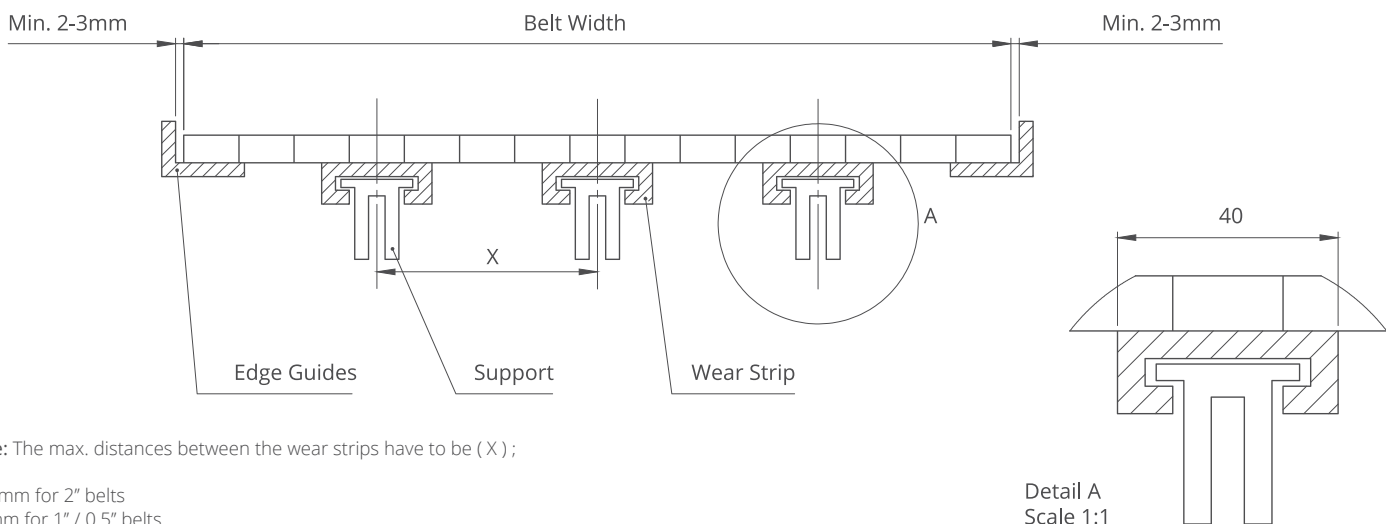

Note: The max. distances between the wear strips have to be (X) ;

125 mm for 2" belts
 80 mm for 1" / 0.5" belts

Detail A
 Scale 1:1

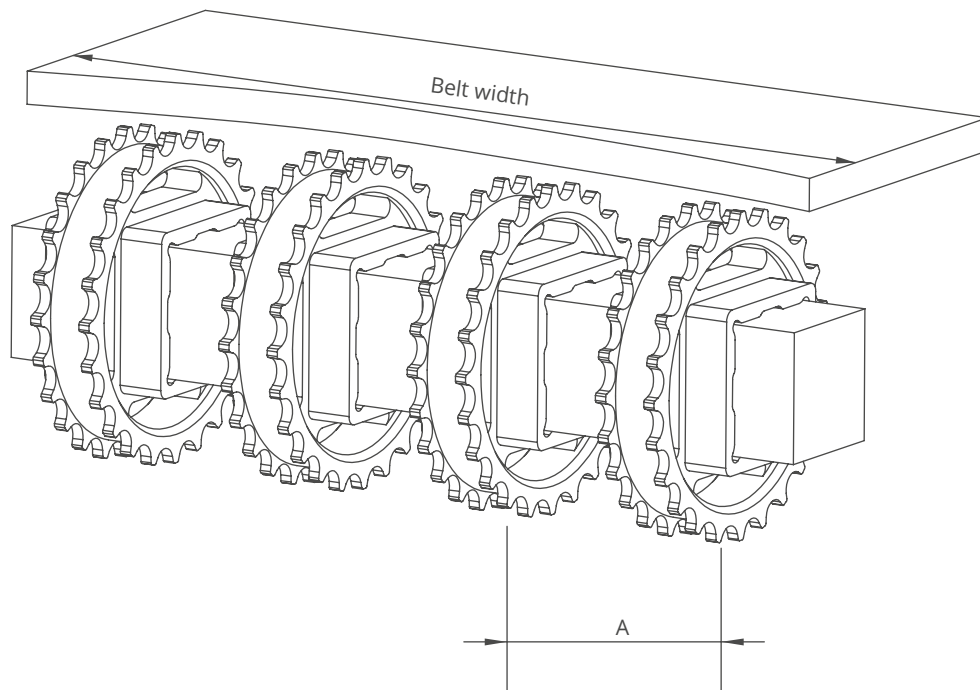

EC127 Series / Sprockets Arrangement

Standard Belt Width		Number of sprockets per shaft		A (mm/inch)	
mm	inch	Drive Shaft	Return Shaft	Min.	Max.
150,0	5.91	2	2	50/2	100/4
200,0	7.87	3	2	50/2	100/4
250,0	9.84	3	2	50/2	100/4
300,0	11.81	4	3	50/2	100/4
350,0	13.78	4	3	50/2	100/4
400,0	15.75	5	3	50/2	100/4
450,0	17.72	5	3	50/2	100/4
500,0	19.69	6	4	50/2	100/4
550,0	21.65	7	4	50/2	100/4
600,0	23.62	7	4	50/2	100/4
650,0	25.59	7	4	50/2	100/4
700,0	27.56	8	5	50/2	100/4
750,0	29.53	9	6	50/2	100/4
800,0	31.50	9	6	50/2	100/4
850,0	33.46	10	7	50/2	100/4
900,0	35.43	11	7	50/2	100/4
950,0	37.40	11	7	50/2	100/4
1000,0	39.37	11	7	50/2	100/4
1050,0	41.34	11	7	50/2	100/4
1100,0	43.31	12	7	50/2	100/4
1150,0	45.28	12	7	50/2	100/4
1200,0	47.24	12	7	50/2	100/4
1250,0	49.21	13	8	50/2	100/4
1300,0	51.18	13	8	50/2	100/4
1350,0	53.15	13	8	50/2	100/4
1400,0	55.12	14	8	50/2	100/4

MD127 GAP%50

Modular Belt Serie

MD127 GAP%50

Sprockets

Engineering Information





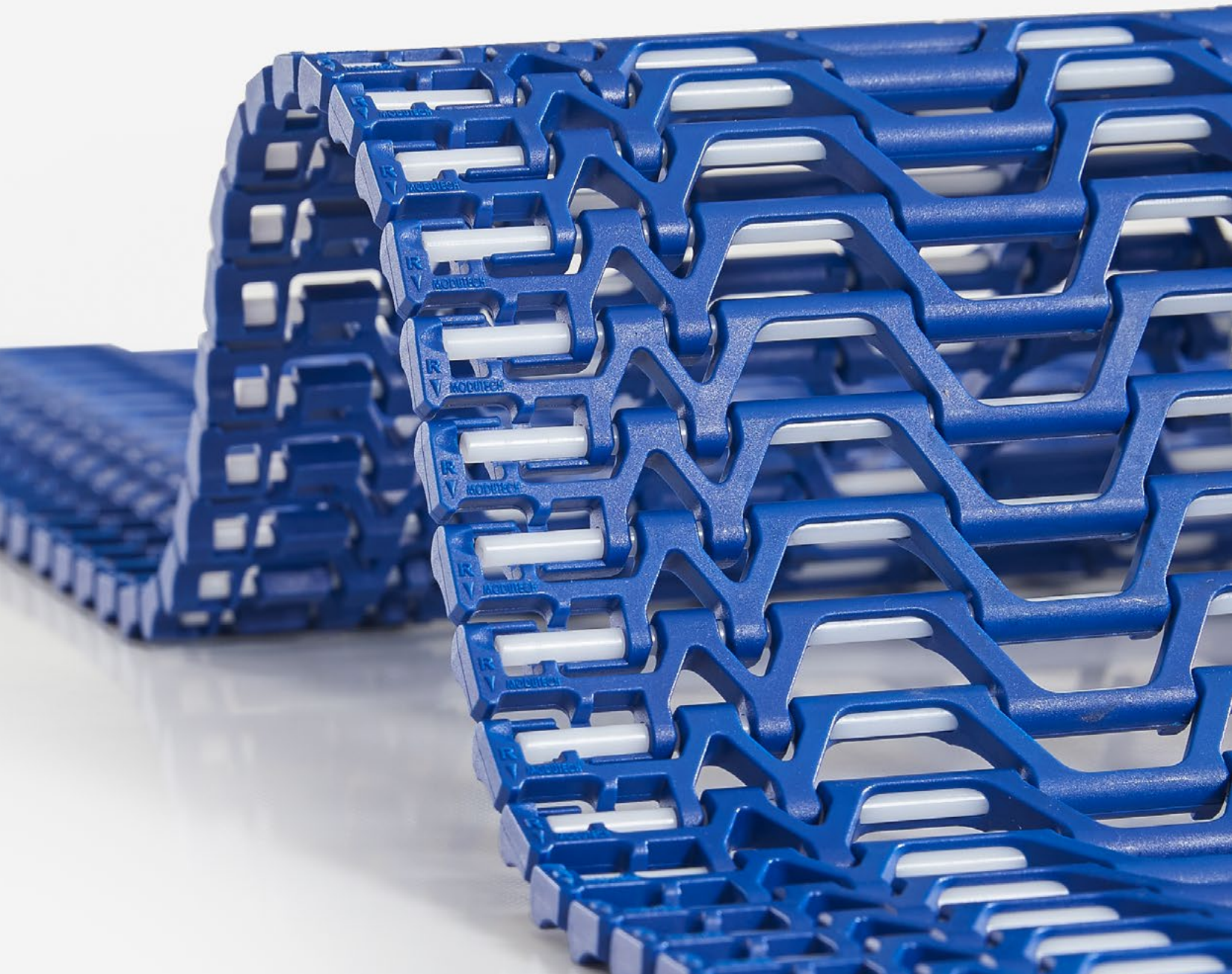

MD127 GAP%50

Modular Belt Serie

- **Bakery Applications**

Including Oven Infeed - Outfeed, Coating Lines, Glazing Lines, Freezing Lines, Conditioning Lines, Cooling Lines

- **Poultry Applications**

Cooling and Freezing Lines

- **Seafood Applications**

Including Breeding Machines, Draining Lines

- **Snack Food Applications**

Including Proofer Lines, Boiler Infeed, Oven Infeed - Outfeed, Cooling Lines

- **Fruits and Vegetables Applications**

Including Prewashing / Rinsing, Draining

- **Packing Industry**

Shrink Tunnels



MD127 GAP%50

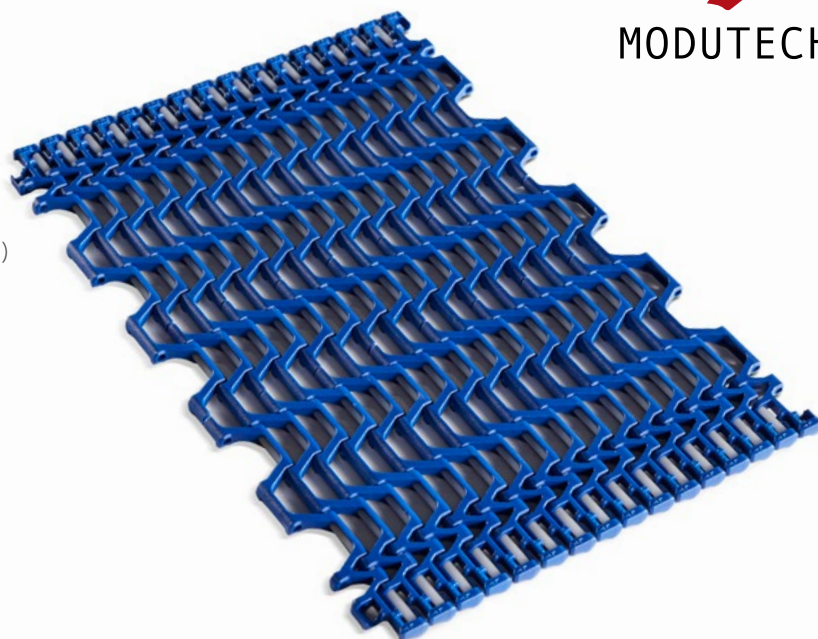

Pitch:	12,7 mm / 0.5 inch
Belt Surface:	Open, Smooth Surface
Minimum Width:	177,8 mm / 7 inch
Open Area (%):	50%. (Biggest opening 10 x 25 mm)
Flight:	No
Sidewall:	No
Rod:	Ø3,6 mm / 0.142 inch
Approved:	FDA and EU
Curve:	No
Color:	Additional colors available
Cleanability:	Excellent
Belt Thickness:	7 mm / 0.276 inch

Product Features and Functional Benefits

- Belt provides optimal open area for drainage and airflow.
- Less friction and product contact for easy cooking, cooling and freezing of products.
- Reduced dirt and oxide build due to self cleaning surface.
- Easy to clean reduces downtime for cleaning time 80%.

Available Moulded Module Sizes

- 203,2 mm / **8 inch** module
- 177,8 mm / **7 inch** module
- 127 mm / **5 inch** module

MD127 GAP%50 / Technical Information

BELT MATERIAL	BELT STRENGTH				TEMPERATURE		BELT WEIGHT
	Straight		Curve		°C / °F (min.)	°C/°F (max.)	Kg/m ² / lb/ft ²
	N/m	lb/ft	N/m	lb/ft			
Polypropylene	3410	233	-	-	+5 / +41	+90 / +194	2,8 / 0.57
Polyethylene	-	-	-	-	-	-	-
Acetal	4840	331	-	-	-43 / -45.4	+110 / +230	3,6 / 0.75

- Belt strength and temperature values are maximum on the table.

MD127 GAP%50 / Standard Belt Widths

BELT SERIES	WIDTH (W)				Belt With Tolerance (max.)
	PP		POM		
	mm	inch	mm	inch	
MD127G50	177,80	7.0	177,80	7.0	± 1 mm
MD127G50	203,20	8.0	203,20	8.0	± 1 mm
MD127G50	304,80	12.0	304,80	12.0	± 1 mm
MD127G50	406,40	16.0	406,40	16.0	± 1 mm
MD127G50	508,00	20.0	508,00	20.0	± 2 mm
MD127G50	609,60	24.0	609,60	24.0	± 2 mm
MD127G50	711,20	28.0	711,20	28.0	± 2 mm
MD127G50	812,80	32.0	812,80	32.0	± 2 mm
MD127G50	914,40	36.0	914,40	36.0	± 2 mm

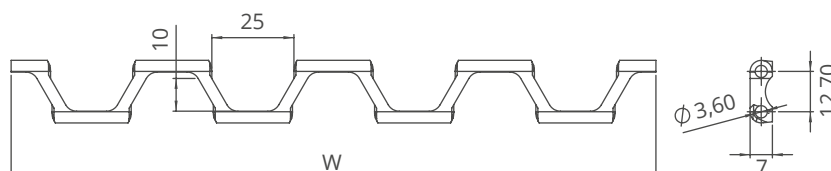

- Standard belt increments 101,6 mm.
- Non-standard belt increments 25,4 mm.
- Please contact with customer service for precise belt measurements.

MD127 GAP%50 Serie *Engineering Information*



Z36

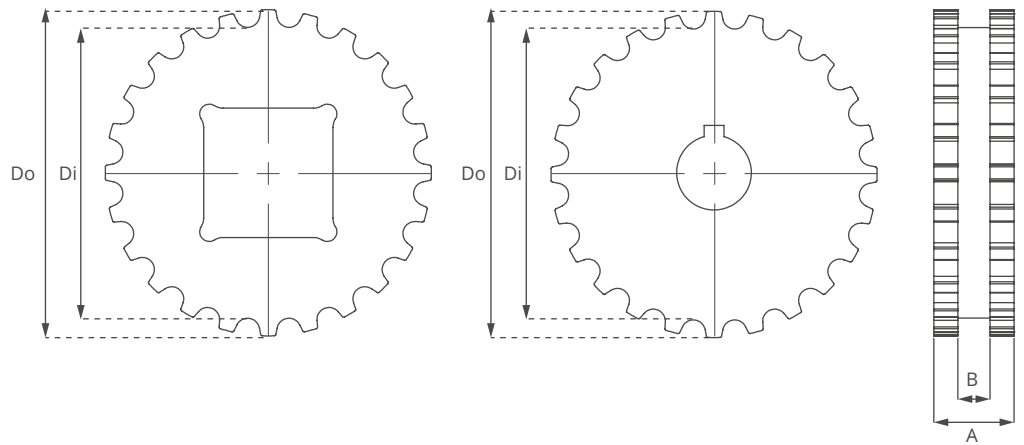

MD127 GAP%50 Serie / Machined Sprockets Dimensions

NO.TEETH	Di mm/inch	Do mm/inch	B mm/inch	A mm/inch	Square Bore (Q) mm/inch	Round Bore (R) mm/inch	PRODUCT CODE	
							Square Type (Q)	Round Type (R)
Z19	70,9 / 2.79	80,8 / 3.18	10 / 0.39	25 / 1.0	20 / 0.78	25 / 1	MD127G50SQZ19	MD127G50SRZ19
Z24	91,3 / 3.59	101,6 / 4.00	10 / 0.39	25 / 1.0	25 / 1	25-40 / 1-1.50	MD127G50SQZ24	MD127G50SRZ24
Z36	140,5 / 5.53	150,5 / 5.93	10 / 0.39	25 / 1.0	40 / 1.57	25-400 / 1-1.50	MD127G50SQZ36	MD127G50SRZ36

*All required sprockets produced by CNC.

*Other sprockets and hub sizes are manufactured up to request.

*POM (Acetal) and PA (Polyamide) sprockets raw material is available on request.

***Machined Split Sprockets are available for each size.**

A - ± 0,031" (1mm)
B - ± 0,125" (3mm)
C - ± (Max.)
E - ± (Min.)

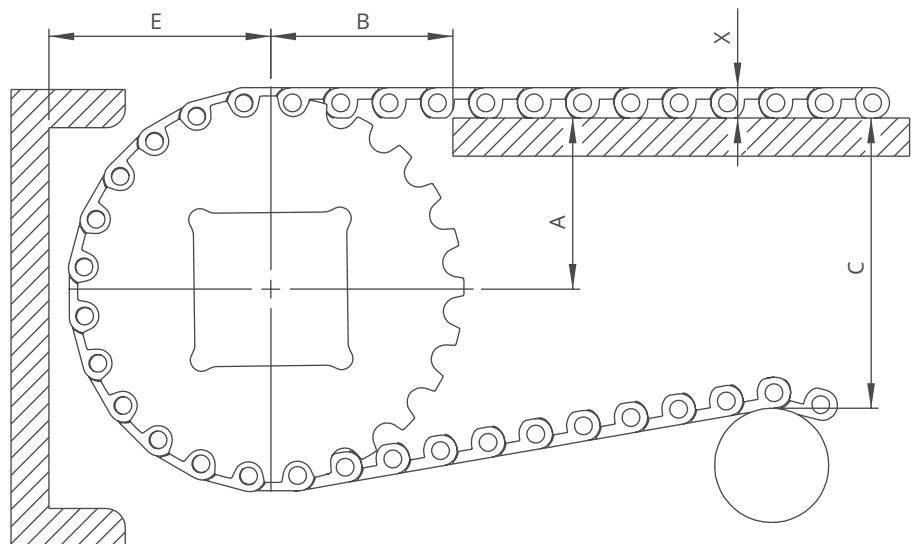

MD127 GAP%50 Serie / Conveyor Frame Dimensions

Sprockets Description		A		B		C		E		X		
Pitch Diameter		Range (Bottom to Top)		Inch	mm	Inch	mm	Inch	mm	Inch	mm	
Inch	mm	No.Teeth	Inch									mm
MD127 GAP%50												
3.09	78,4	19	1.40	35,4	1.59	40,4	2.00	50,9	1.87	47,4	0.28	7,0
3.86	98,0	24	1.80	45,7	2.00	50,8	2.81	71,3	2.27	57,7	0.28	7,0
5.83	148,0	36	2.77	70,3	2.97	75,5	4.74	120,5	3.24	82,3	0.28	7,0

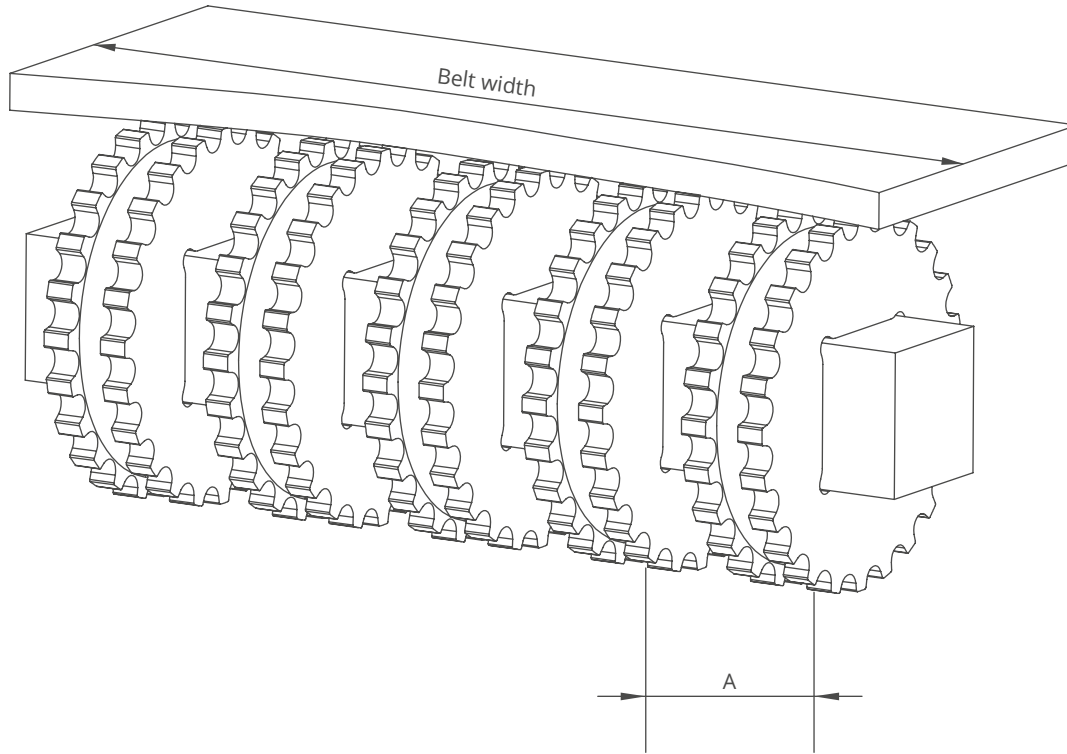

MD127 GAP%50 Serie / Sprockets Arrangement

Standard Belt Width		Number of sprockets per shaft		A (mm/inch)	
mm	inch	Drive Shaft	Return Shaft	Min.	Max.
177,8	7.0	2	2	50/2	100/4
203,2	8.0	3	2	50/2	100/4
304,8	12.0	4	3	50/2	100/4
406,4	16.0	5	3	50/2	100/4
508,0	20.0	6	4	50/2	100/4
609,6	24.0	7	5	50/2	100/4
711,2	28.0	8	6	50/2	100/4
812,8	32.0	9	7	50/2	100/4
914,4	36.0	10	8	50/2	100/4
1016,0	40.0	11	9	50/2	100/4
1117,6	44.0	12	9	50/2	100/4
1219,2	48.0	13	10	50/2	100/4
1320,8	52.0	14	11	50/2	100/4
1422,4	56.0	14	11	50/2	100/4
1524,0	60.0	15	12	50/2	100/4
1625,6	64.0	16	12	50/2	100/4

HC127 C

Modular Belt Series

HC127 C

Sprockets

Engineering Information







HC127 C

Modular Belt Serie

- **Meat (Beef and Pork) Applications**

Fat - Trim Lines, General Conveyence, Packing Lines, Elevator

- **Poultry Applications**

Debonning, Trim Lines, Offal - Feather Lines, Grading Lines, Freezing Lines, Elevator

- **Seafood Applications**

Inspection Tables, Grading Lines, Trim Lines

- **Bakery Applications**

Row Dough Handling, Cooling Lines, Packing Lines

- **Snack Food Applications**

Corn Processing

- **Fruits and Vegetables Applications**

Bulk Feeding, Elevator, Control - Sorting Table

- **Packaging Applications**

Labelling, Palletizing - Depalletizing



HC127 C

Pitch:	12,7 mm / 0.5 inch
Belt Surface:	Close, Smooth Surface
Minimum Width:	101,6 mm / 4 inch
Open Area (%):	0%
Flight:	No
Sidewall:	No
Rod:	Ø4,5 mm / 0.177 inch
Approved:	FDA and EU
Curve:	No
Color:	Additional colors available
Cleanability:	Excellent
Belt Thickness:	8 mm / 0.315 inch

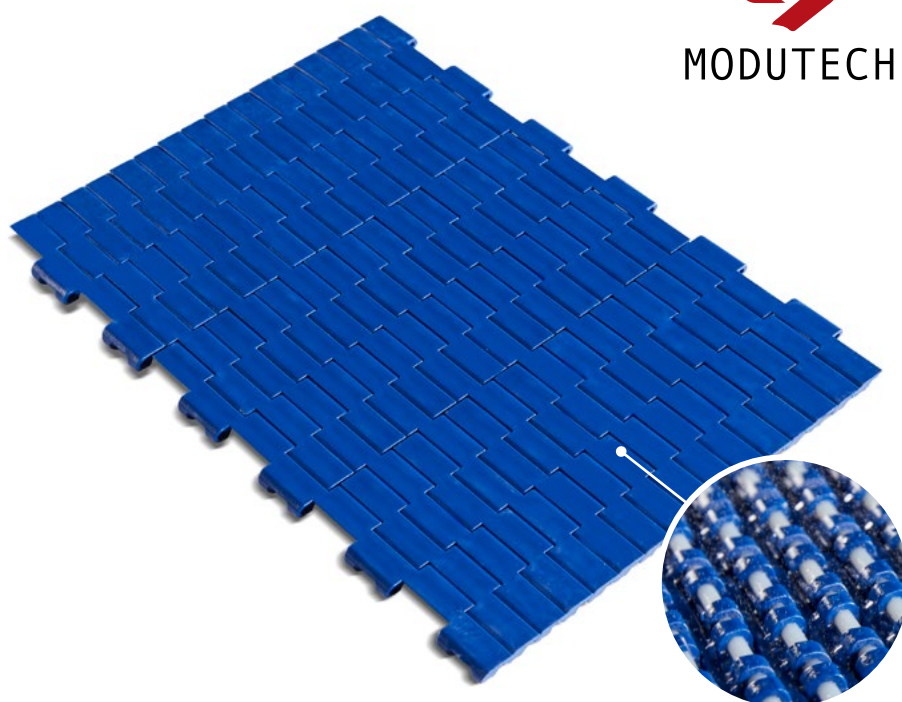

Product Features and Functional Benefits

- Easy to clean reduces downtime for cleaning time 80%.
- Unique sprocket engagement - higher product load and longer conveyors.
- Close transfer applications.
- Reduces bacteria growth.

Available Moulded Module Sizes

- 203,2 mm / **8 inch** module
- 101,6 mm / **4 inch** module

HC127 C / Technical Information

BELT MATERIAL	BELT STRENGTH				TEMPERATURE		BELT WEIGHT
	Straight		Curve		°C / °F (min.)	°C/°F (max.)	
	N/m	lb/ft	N/m	lb/ft			Kg/m ² / lb/ft ²
Polypropylene	2750	188	-	-	+5 / +41	+90 / +194	3,8 / 0.78
Polyethylene	-	-	-	-	-	-	-
Acetal	5170	354	-	-	-43 / -45.4	+110 / +230	5,7 / 1.17

- Belt strength and temperature values are maximum on the table.

HC127 C / Standard Belt Widths

BELT SERIES	WIDTH (W)				Belt With Tolerance (max.)
	PP		POM		
	mm	inch	mm	inch	
HC127 C	101,60	4.0	101,60	4.0	± 1 mm
HC127 C	203,20	8.0	203,20	8.0	± 1 mm
HC127 C	304,80	12.0	304,80	12.0	± 1 mm
HC127 C	406,40	16.0	406,40	16.0	± 1 mm
HC127 C	508,00	20.0	508,00	20.0	± 2 mm
HC127 C	609,60	24.0	609,60	24.0	± 2 mm
HC127 C	711,20	28.0	711,20	28.0	± 2 mm
HC127 C	812,80	32.0	812,80	32.0	± 2 mm
HC127 C	914,40	36.0	914,40	36.0	± 2 mm

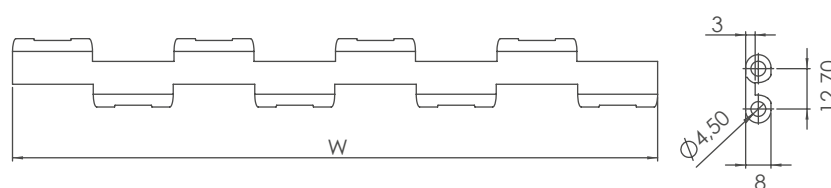

- Standard belt increments 101,6 mm.
- Non-standard belt increments 25,4 mm.
- Please contact with customer service for precise belt measurements.

HC127 C Serie *Engineering Information*



Z36

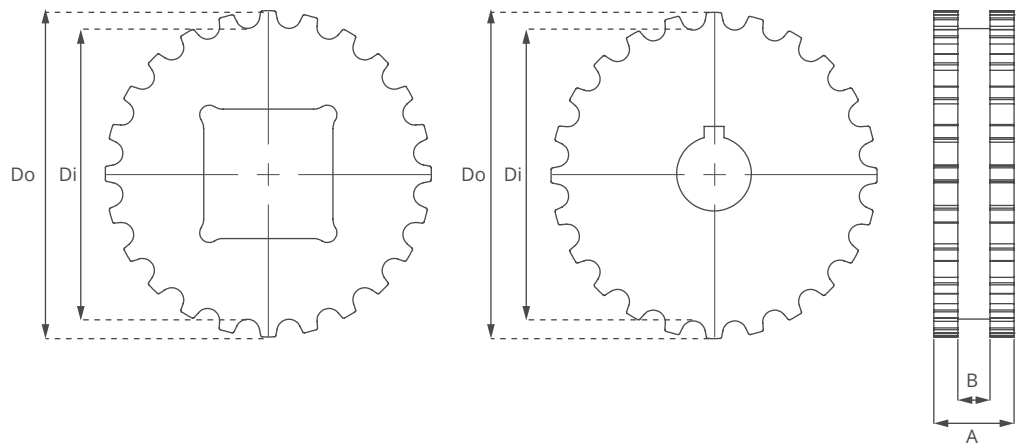

HC127 C Serie / Machined Sprockets Dimensions

NO.TEETH	Di mm/inch	Do mm/inch	B mm/inch	A mm/inch	Square Bore (Q) mm/inch	Round Bore (R) mm/inch	PRODUCT CODE	
							Square Type (Q)	Round Type (R)
Z19	69,4 / 2.73	79,3 / 3.12	10 / 0.36	25 / 1.0	20 / 0.78	25 / 1	HC127SQZ19	HC127SRZ19
Z24	89,8 / 3.54	100,0 / 3.94	10 / 0.36	25 / 1.0	25 / 1	25-30 / 1-1.25	HC127SQZ24	HC127SRZ24
Z36	139,0 / 5.47	149,4 / 5.88	10 / 0.36	25 / 1.0	40 / 1.57	25-30 / 1-1.25	HC127SQZ36	HC127SRZ36

*All required sprockets produced by CNC.

*Other sprockets and hub sizes are manufactured up to request.

*POM (Acetal) and PA (Polyamide) sprockets raw material is available on request.

***Machined Split Sprockets are available for each size.**

A - ± 0,031" (1mm)
B - ± 0,125" (3mm)
C - ± (Max.)
E - ± (Min.)

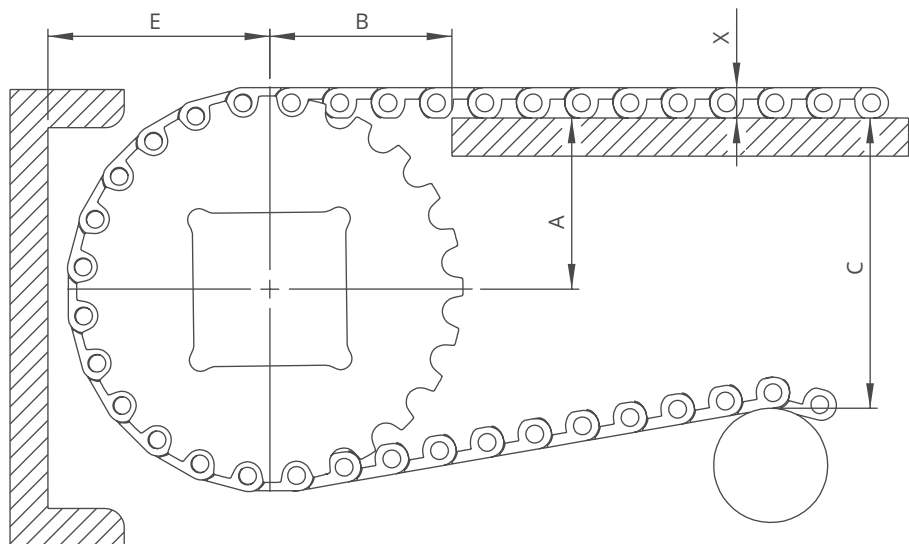

HC127 C Serie / Conveyor Frame Dimensions

Sprockets Description		A		B		C		E		X		
Pitch Diameter		Range (Bottom to Top)		Inch	mm	Inch	mm	Inch	mm	Inch	mm	
Inch	mm	No.Teeth	Inch									mm
HC127 C												
3.09	78,4	19	1.37	34,7	1.56	39,7	1.94	49,4	1.84	46,7	0.31	8,0
3.86	98,0	24	1.77	44,9	1.97	50,0	2.75	69,8	2.24	56,9	0.31	8,0
5.83	148,0	36	2.74	69,5	2.94	74,7	4.69	119,0	3.21	81,5	0.31	8,0

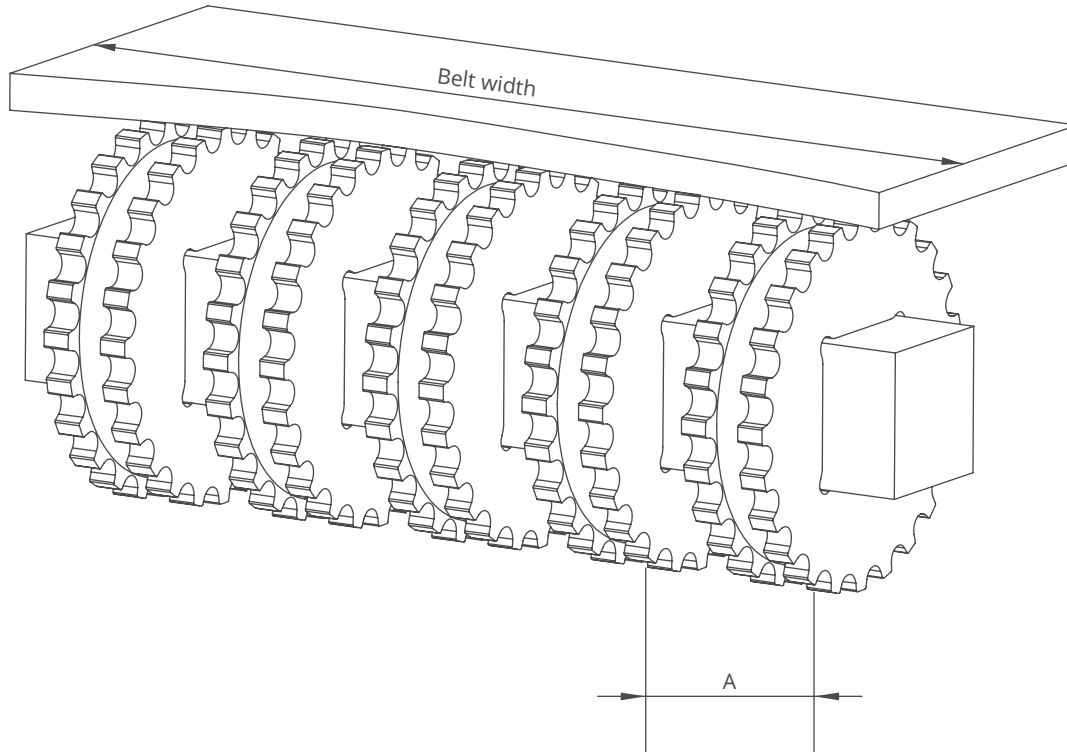

HC127 C Serie / Sprockets Arrangement

Standard Belt Width		Number of sprockets per shaft		A (mm/inch)	
mm	inch	Drive Shaft	Return Shaft	Min.	Max.
101,6	4.0	2	2	50/2	100/4
203,2	8.0	3	2	50/2	100/4
304,8	12.0	4	3	50/2	100/4
406,4	16.0	5	3	50/2	100/4
508,0	20.0	6	4	50/2	100/4
609,6	24.0	7	5	50/2	100/4
711,2	28.0	8	6	50/2	100/4
812,8	32.0	9	7	50/2	100/4
914,4	36.0	10	8	50/2	100/4
1016,0	40.0	11	9	50/2	100/4
1117,6	44.0	12	9	50/2	100/4
1219,2	48.0	13	10	50/2	100/4
1320,8	52.0	14	11	50/2	100/4
1422,4	56.0	14	11	50/2	100/4
1524,0	60.0	15	12	50/2	100/4
1625,6	64.0	16	12	50/2	100/4

XP254

Corrugated Belt Series

XP254 CR

XP254 FLT CR

Sprockets

Engineering Information







XP254 CR

Corrugated Belt Series

• Corrugated Cardbord Applications

Down Stackers, Corrugator Take Off, Strap Feed



Safety first because
Modutech cares about you!
Non-Skid surface offers safety
through walking for corrugated
industry .



XP254 CR

Pitch:	25,4 mm / 1 inch
Belt Surface:	Close, Non Slip Surface
Minimum Width:	76,2 mm / 3 inch
Open Area (%):	0%
Flight:	No
Sidewall:	No
Rod:	Ø4,5 mm / 0.177 inch - Self Lock
Approved:	No
Curve:	No
Color:	Additional colors available
Cleanability:	Good
Belt Thickness:	9,3 mm / 0.366 inch

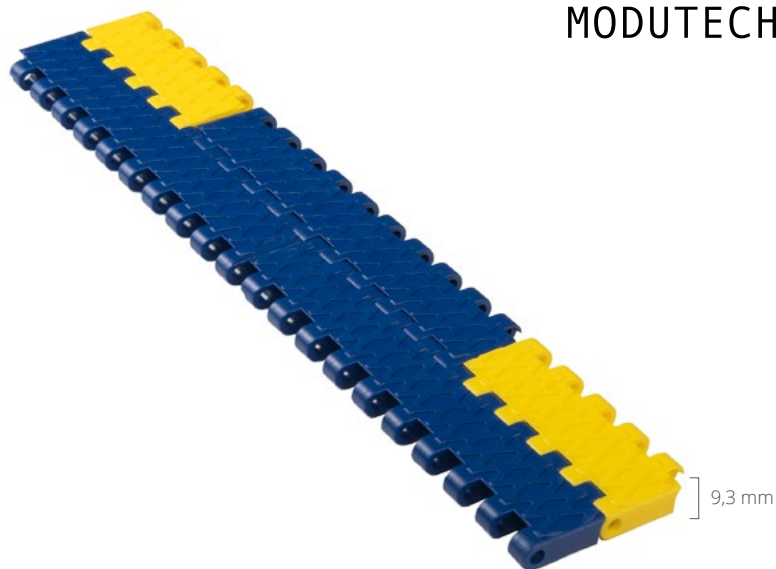

Product Features and Functional Benefits

- Chamfered belt edges.
- Reinforced bottom surface - higher product load and longer conveyors.
- Unique sprocket engagement reduces pulsation and increases load capacity.
- Close transfer applications.
- Extra power, bi-directional belt for long conveyors.
- Safety walking top surface.

Available Moulded Module Sizes

- 152,4 mm / **6 inch** module
- 76,2 mm / **3 inch** module

XP254 CR / Technical Information

BELT / PIN MATERIAL	BELT STRENGTH				TEMPERATURE		BELT WEIGHT
	Straight		Curve		°C / °F (min.)	°C / °F (max.)	Kg/m ² / lb/ft ²
	N/m	lb/ft	N/m	lb/ft			
Acetal / PA6	40250	2758	-	-	-43 / -45.4	+110 / +230	8,1 / 1.67

- Belt strength and temperature values are maximum on the table.

XP254 CR / Standard Belt Widths

BELT SERIES	WIDTH (W)				Belt With Tolerance (max.)
	PP-PE		POM		
	mm	inch	mm	inch	
XP254 CR	-	-	76,2	3.0	± 0,5 mm
XP254 CR	-	-	152,4	6.0	± 0,5 mm
XP254 CR	-	-	228,6	9.0	± 2 mm
XP254 CR	-	-	304,8	12.0	± 2 mm
XP254 CR	-	-	381,0	15.0	± 3 mm
XP254 CR	-	-	457,2	18.0	± 3 mm
XP254 CR	-	-	533,4	21.0	± 3 mm
XP254 CR	-	-	609,6	24.0	± 3 mm
XP254 CR	-	-	685,8	27.0	± 4 mm
XP254 CR	-	-	762,0	30.0	± 4 mm
XP254 CR	-	-	838,2	33.0	± 4 mm
XP254 CR	-	-	914,4	36.0	± 4 mm
XP254 CR	-	-	990,6	39.0	± 4 mm
XP254 CR	-	-	1066,8	42.0	± 4 mm
XP254 CR	-	-	1143,0	45.0	± 4 mm

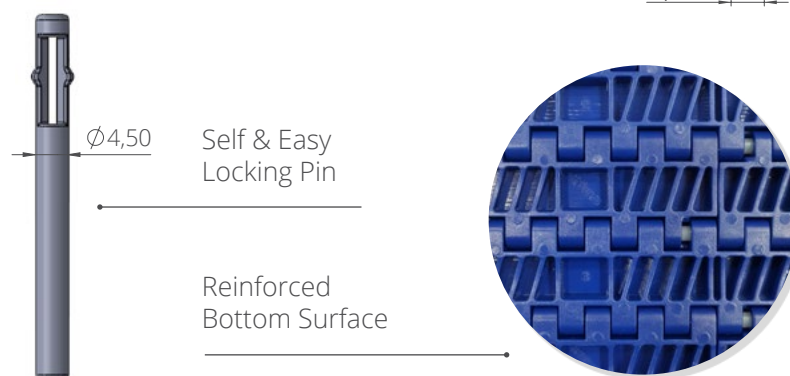
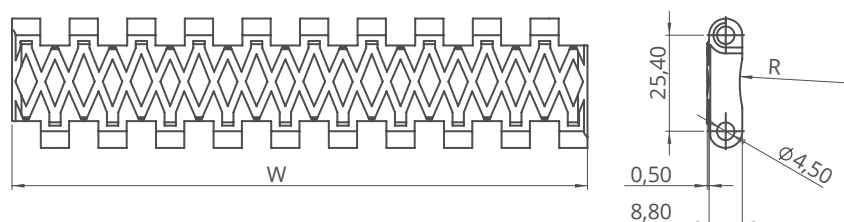

- Standard belt increments 76,2 mm.
 - Please contact with customer service for precise belt measurements.



XP254 FLT CR

Corrugated Belt Series

• Corrugated Cardbord Applications

Down Stackers, Corrugator Take Off, Strap Feed



XP254 FLT CR

Pitch:	25,4 mm / 1 inch
Belt Surface:	Close, Smooth Surface
Minimum Width:	76,2 mm / 3 inch
Open Area (%):	0%
Flight:	No
Sidewall:	No
Rod:	Ø4,5 mm / 0.177 inch - Self Lock
Approved:	No
Curve:	No
Color:	Additional colors available
Cleanability:	Good
Belt Thickness:	8,8 mm / 0.346 inch

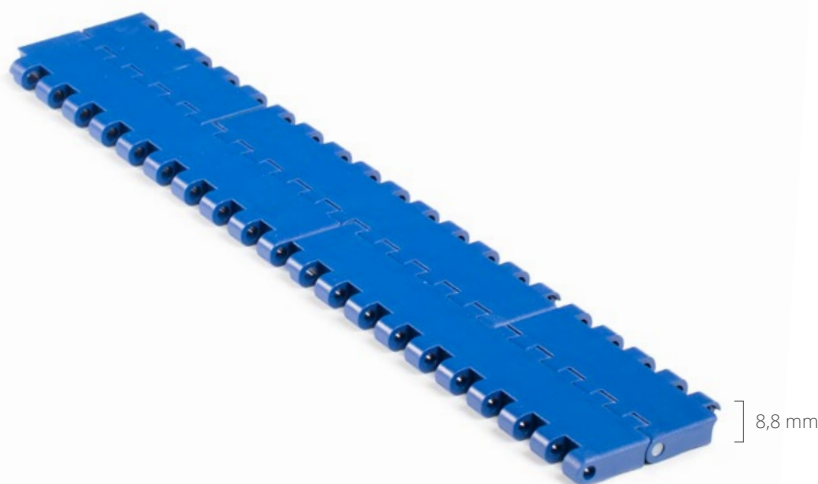

Product Features and Functional Benefits

- Chamfered belt edges.
- Reinforced bottom surface - higher product load and longer conveyors.
- Unique sprocket engagement reduces pulsation and increases load capacity.
- Close transfer applications.
- Extra power, bi-directional belt for long conveyors.

Available Moulded Module Sizes

- 152,4 mm / **6 inch** module
- 76,2 mm / **3 inch** module

XP254 FLT CR / Technical Information

BELT / PIN MATERIAL	BELT STRENGTH				TEMPERATURE		BELT WEIGHT
	Straight		Curve		°C / °F (min.)	°C / °F (max.)	
	N/m	lb/ft	N/m	lb/ft			Kg/m ² / lb/ft ²
Acetal / PA6	40250	2758	-	-	-43 / -45.4	+110 / +230	8,1 / 1.67

- Belt strength and temperature values are maximum on the table.

XP254 FLT CR / Standard Belt Widths

BELT SERIES	WIDTH (W)				Belt With Tolerance (max.)
	PP-PE		POM		
	mm	inch	mm	inch	
XP254 FLT CR	-	-	76,2	3.0	± 0,5 mm
XP254 FLT CR	-	-	152,4	6.0	± 0,5 mm
XP254 FLT CR	-	-	228,6	9.0	± 2 mm
XP254 FLT CR	-	-	304,8	12.0	± 2 mm
XP254 FLT CR	-	-	381,0	15.0	± 3 mm
XP254 FLT CR	-	-	457,2	18.0	± 3 mm
XP254 FLT CR	-	-	533,4	21.0	± 3 mm
XP254 FLT CR	-	-	609,6	24.0	± 3 mm
XP254 FLT CR	-	-	685,8	27.0	± 4 mm
XP254 FLT CR	-	-	762,0	30.0	± 4 mm
XP254 FLT CR	-	-	838,2	33.0	± 4 mm
XP254 FLT CR	-	-	914,4	36.0	± 4 mm
XP254 FLT CR	-	-	990,6	39.0	± 4 mm
XP254 FLT CR	-	-	1066,8	42.0	± 4 mm
XP254 FLT CR	-	-	1143,0	45.0	± 4 mm

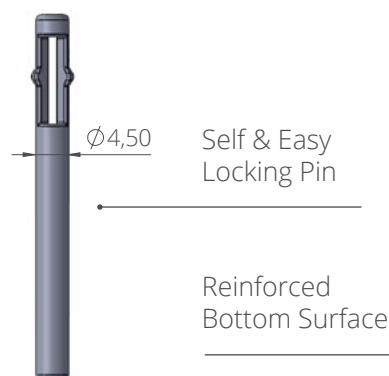
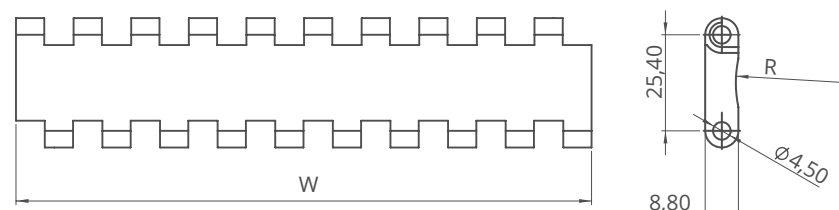

- Standard belt increments 76,2 mm.
 - Please contact with customer service for precise belt measurements.

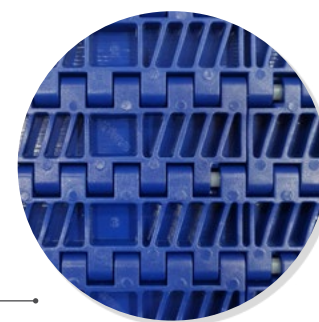

XP254

Modular Belt Series

XP254 C

XP254 PR %22

XP254 FG

Sprockets & Accessories

Engineering Information







XP254 C

Modular Belt Series

- **Seafood Applications**

Inspection Tables, Grading Lines, Trim Lines

- **Bakery Applications**

Row Dough Handling, Cooling Lines, Packing Lines

- **Snack Food Applications**

Corn Processing

- **Fruits and Vegetables Applications**

Bulk Feeding, Elevator, Control - Sorting Table

- **Tire Manufacturing Applications**

Mixer Infeed - Outfeed, Calendering Infeed, Extrusion Outfeed

- **Packaging Applications**

Labelling, Case Packers, Tray Packers, Palletizing - Depalletizing

- **Printing and Paper Applications**

Printing Machine Outfeed, Wrapping Machine Outfeed

- **Beverages and Bottling Applications**

Can Palletizing and Depalletizing, Glass Palletizing and Depalletizing,

Pet Palletizing and Depalletizing

- **Material Handling Applications**

Incline Applications, Palletizers, Packaging Lines



XP254 C

Pitch:	25,4 mm / 1 inch
Belt Surface:	Close, Smooth Surface
Minimum Width:	50 mm / 1.97 inch
Open Area (%):	0%
Flight:	Yes (T25, T50, T75, T100)
Sidewall:	Yes (h=25 mm, h=50 mm, h=75 mm, h=100 mm)
Rod:	Ø4,5 mm / 0.177 inch - Self Lock
Approved:	FDA and EU
Curve:	No
Color:	Additional colors available
Cleanability:	Good
Belt Thickness:	8.8 mm / 0.346 inch

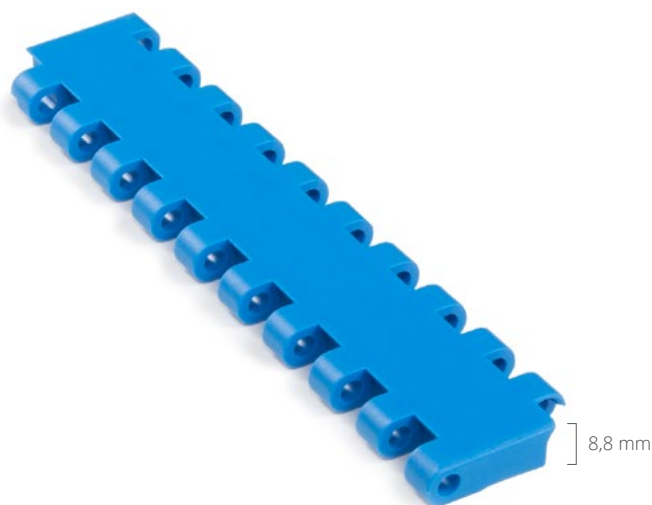

Product Features and Functional Benefits

- Unique sprocket engagement - higher product load and longer conveyors.
- Unique sprocket engagement reduces pulsation and increases load capacity.
- Close transfer applications.
- Extra power, bi-directional belt for long conveyors.
- Chamfered belt edges.

Available Moulded Module Sizes

- 152,4 mm / **6 inch** module
- 76,2 mm / **3 inch** module

XP254 C / Technical Information

BELT MATERIAL	BELT STRENGTH				TEMPERATURE		BELT WEIGHT
	Straight		Curve		°C / °F (min.)	°C / °F (max.)	
	N/m	lb/ft	N/m	lb/ft			Kg/m ² / lb/ft ²
Polypropylene	18400	1260.80	-	-	+5 / +41	+90 / +194	5,50 / 1.13
Polyethylene	9100	623.55	-	-	-73 / -99.4	+66 / +150.8	5,80 / 1.19
Acetal	32100	2199.55	-	-	-43 / -45.4	+110 / +230	7,90 / 1.62

- Belt strength and temperature values are maximum on the table.

XP254 C / Standard Belt Widths

BELT SERIES	WIDTH (W)				Belt With Tolerance (max.)
	PP-PE		POM		
	mm	inch	mm	inch	
XP254 C	152,4	6.0	152,4	6.0	± 0,5 mm
XP254 C	228,6	9.0	228,6	9.0	± 2 mm
XP254 C	304,8	12.0	304,8	12.0	± 2 mm
XP254 C	381,0	15.0	381,0	15.0	± 3 mm
XP254 C	457,2	18.0	457,2	18.0	± 3 mm
XP254 C	533,4	21.0	533,4	21.0	± 3 mm
XP254 C	609,6	24.0	609,6	24.0	± 3 mm
XP254 C	685,8	27.0	685,8	27.0	± 4 mm
XP254 C	762,0	30.0	762,0	30.0	± 4 mm
XP254 C	838,2	33.0	838,2	33.0	± 4 mm
XP254 C	914,4	36.0	914,4	36.0	± 4 mm
XP254 C	990,6	39.0	990,6	39.0	± 4 mm
XP254 C	1066,8	42.0	1066,8	42.0	± 4 mm
XP254 C	1143,0	45.0	1143,0	45.0	± 4 mm

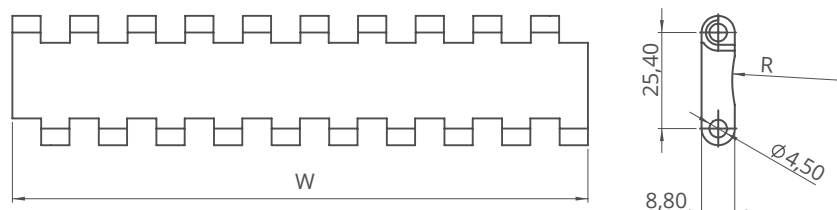

- Standard belt increments 76,2 mm.
- Non-standard belt increments 15,2 mm.
- Please contact with customer service for precise belt measurements.



XP254 PR%22

Modular Belt Series

• Meat and Poultry Applications

General Conveyance and Breeding Lines

• Fruit and Vegetable Application

Elevators, Steam Peeler, Inspection Tables, Blanching Lines

• Seafood Applications

Elevators, Inspection Tables, Grading Lines, Trim Lines, Glazing Lines, Cooking Lines

• Bakery Applications

*Row Dough Handling, Cooling Lines, Icing Lines, Packing Lines,
Metal Detectors*



XP254 PR%22

Pitch:	25,4 mm / 1 inch
Belt Surface:	Open, Smooth Surface
Minimum Width:	50 mm / 1.97 inch
Open Area (%):	22%. (Biggest opening 9,44 x 3 mm)
Flight:	Yes (T25, T50, T75, T100)
Sidewall:	Yes (h=25 mm, h=50 mm, h=75 mm, h=100 mm)
Rod:	Ø4,5 mm / 0.177 inch - Self Lock
Approved:	FDA and EU
Curve:	No
Color:	Additional colors available
Cleanability:	Good
Belt Thickness:	8,8 mm / 0.346 inch

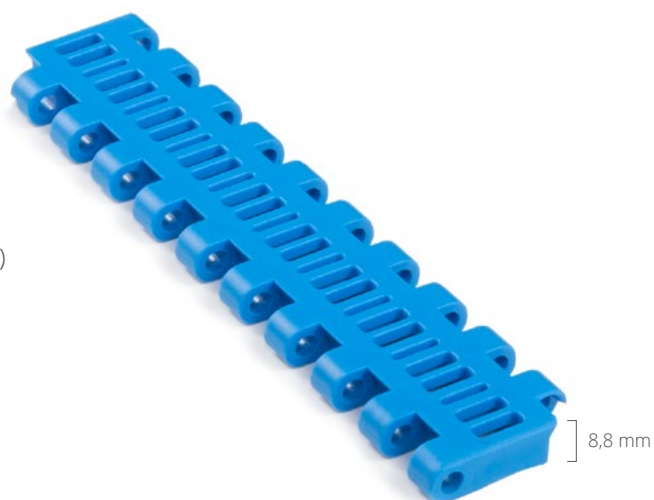

Product Features and Functional Benefits

- Unique sprocket engagement - precise indexing, easy cleaning.
- Different openings to optimize performance in cooling and draining applications.
- Extra power, bi-directional belt for long conveyors.
- Unique sprocket engagement reduces pulsation and increases load capacity.
- Chamfered belt edges.

Available Moulded Module Sizes

- 152,4 mm / **6 inch** module
- 76,2 mm / **3 inch** module

XP254 PR%22 / Technical Information

BELT MATERIAL	BELT STRENGTH				TEMPERATURE		BELT WEIGHT
	Straight		Curve		°C / °F (min.)	°C / °F (max.)	
	N/m	lb/ft	N/m	lb/ft			Kg/m ² / lb/ft ²
Polypropylene	18400	1260.80	-	-	+5 / +41	+90 / +194	5,50 / 1.13
Polyethylene	9100	623.55	-	-	-73 / -99.4	+66 / +150.8	5,80 / 1.19
Acetal	32100	2199.55	-	-	-43 / -45.4	+110 / +230	7,90 / 1.62

- Belt strength and temperature values are maximum on the table.

XP254 PR%22 / Standard Belt Widths

BELT SERIES	WIDTH (W)				Belt With Tolerance (max.)
	PP-PE		POM		
	mm	inch	mm	inch	
XP254 PR22	152,4	6.0	152,4	6.0	± 0,5 mm
XP254 PR22	228,6	9.0	228,6	9.0	± 2 mm
XP254 PR22	304,8	12.0	304,8	12.0	± 2 mm
XP254 PR22	381,0	15.0	381,0	15.0	± 3 mm
XP254 PR22	457,2	18.0	457,2	18.0	± 3 mm
XP254 PR22	533,4	21.0	533,4	21.0	± 3 mm
XP254 PR22	609,6	24.0	609,6	24.0	± 3 mm
XP254 PR22	685,8	27.0	685,8	27.0	± 4 mm
XP254 PR22	762,0	30.0	762,0	30.0	± 4 mm
XP254 PR22	838,2	33.0	838,2	33.0	± 4 mm
XP254 PR22	914,4	36.0	914,4	36.0	± 4 mm
XP254 PR22	990,6	39.0	990,6	39.0	± 4 mm
XP254 PR22	1066,8	42.0	1066,8	42.0	± 4 mm
XP254 PR22	1143,0	45.0	1143,0	45.0	± 4 mm

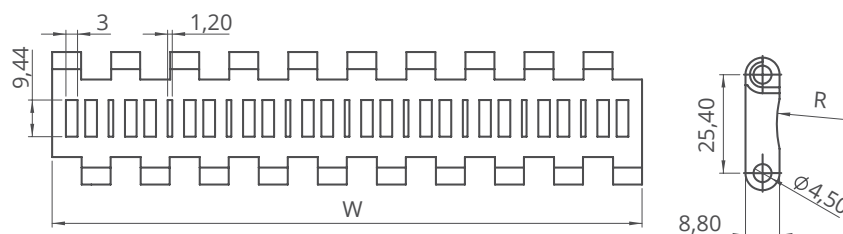

- Standard belt increments 76,2 mm.
- Non-standard belt increments 15,2 mm.
- Please contact with customer service for precise belt measurements.



XP254 FG

Modular Belt Series

• Seafood Applicaitons

Breeding Machines, Draining Lines, Glazing Lines, Elevators, Freezing Lines

• Snack Food Applications

Proofer Lines, Boiler Infeed, Oven Infeed - Outfeed, Cooling Lines

• Fruits and Vegetables Applications

Prewashing - Rinsing, Draining, Blanching Lines, Elevators

• Packaging Applications

Filling, Accumulation Palletizing - Depalletizing, Box Transfer

• Textile Applications

Cutter, Dyeing



XP254 FG

Pitch:	25,4 mm / 1 inch
Belt Surface:	Open, Smooth Surface
Minimum Width:	50 mm / 1.97 inch
Open Area (%):	28%. (Biggest opening 8,44 x 9,44 mm)
Flight:	Yes (T25, T50, T75, T100)
Sidewall:	Yes (h=25 mm, h=50 mm, h=75 mm, h=100 mm)
Rod:	Ø4,5 mm / 0.177 inch - Self Lock
Approved:	FDA and EU
Curve:	No
Color:	Additional colors available
Cleanability:	Good
Belt Thickness:	8,8 mm / 0.346 inch

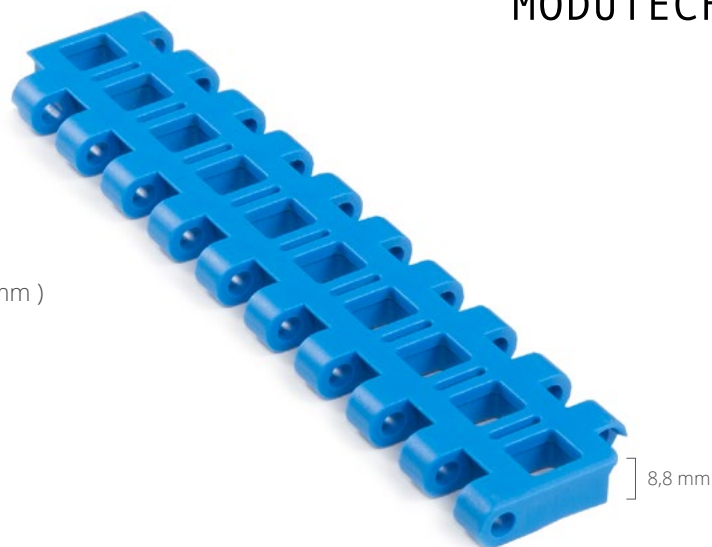

Product Features and Functional Benefits

- Unique sprocket engagement - precise indexing, easy cleaning.
- Different openings to optimize performance in cooling and draining applications.
- Extra power, bi-directional belt for long conveyors.
- Unique sprocket engagement reduces pulsation and increases load capacity.
- Chamfered belt edges.

Available Moulded Module Sizes

- 152,4 mm / **6 inch** module
- 76,2 mm / **3 inch** module

XP254 FG / Technical Information

BELT MATERIAL	BELT STRENGTH				TEMPERATURE		BELT WEIGHT
	Straight		Curve		°C / °F (min.)	°C / °F (max.)	
	N/m	lb/ft	N/m	lb/ft			Kg/m ² / lb/ft ²
Polypropylene	18400	1260.80	-	-	+5 / +41	+90 / +194	5,50 / 1.13
Polyethylene	9100	623.55	-	-	-73 / -99.4	+66 / +150.8	5,80 / 1.19
Acetal	32100	2199.55	-	-	-43 / -45.4	+110 / +230	7,90 / 1.62

- Belt strength and temperature values are maximum on the table.

XP254 FG / Standard Belt Widths

BELT SERIES	WIDTH (W)				Belt With Tolerance (max.)
	PP-PE		POM		
	mm	inch	mm	inch	
XP254 FG	152,4	6.0	152,4	6.0	± 0,5 mm
XP254 FG	228,6	9.0	228,6	9.0	± 2 mm
XP254 FG	304,8	12.0	304,8	12.0	± 2 mm
XP254 FG	381,0	15.0	381,0	15.0	± 3 mm
XP254 FG	457,2	18.0	457,2	18.0	± 3 mm
XP254 FG	533,4	21.0	533,4	21.0	± 3 mm
XP254 FG	609,6	24.0	609,6	24.0	± 3 mm
XP254 FG	685,8	27.0	685,8	27.0	± 4 mm
XP254 FG	762,0	30.0	762,0	30.0	± 4 mm
XP254 FG	838,2	33.0	838,2	33.0	± 4 mm
XP254 FG	914,4	36.0	914,4	36.0	± 4 mm
XP254 FG	990,6	39.0	990,6	39.0	± 4 mm
XP254 FG	1066,8	42.0	1066,8	42.0	± 4 mm
XP254 FG	1143,0	45.0	1143,0	45.0	± 4 mm

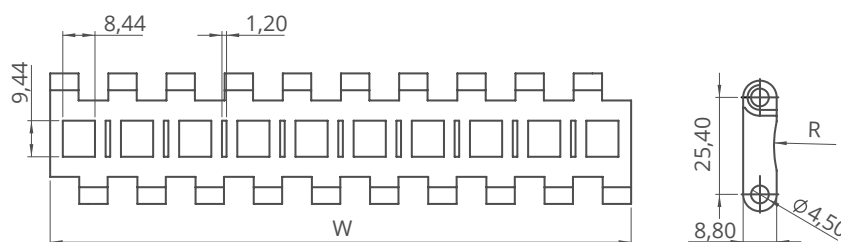

- Standard belt increments 76,2 mm.
- Non-standard belt increments 15,2 mm.
- Please contact with customer service for precise belt measurements.

XP254 Series Sprockets and Technical Specifications



Z18



Z18

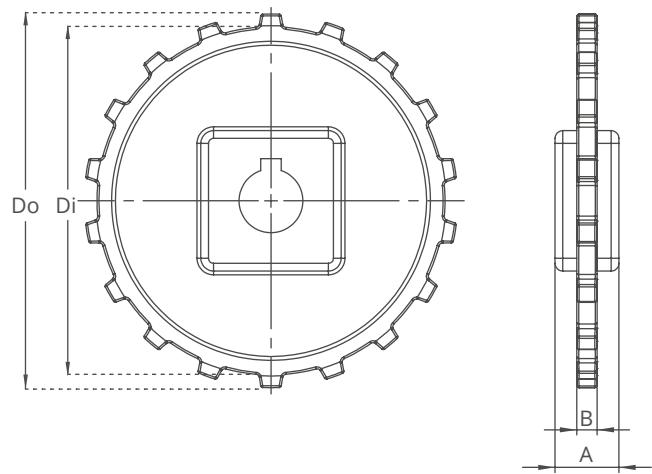
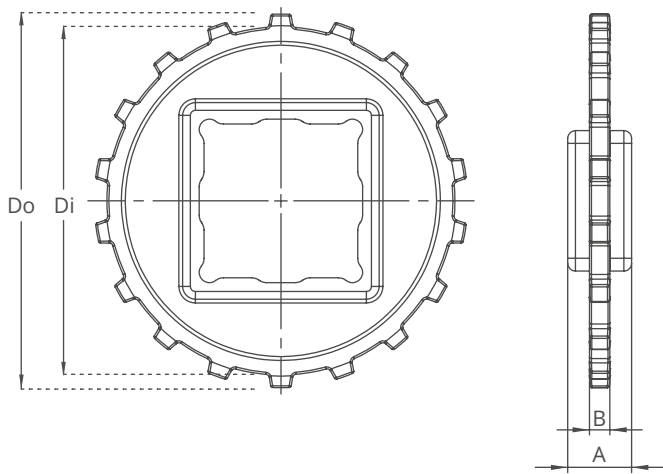

- Split moulded sprockets are available for XP254 Z15 & Z18!

XP254 Series / Standard Sprockets Dimensions

NO. TEETH	Di mm/inch	Do mm/inch	B mm/inch	A mm/inch	Square Bore (Q) mm/inch	Round Bore (R) mm/inch	PRODUCT CODE	
							Square Type (Q)	Round Type (R)
Z8	53,2 / 2.09	64,0 / 2.52	8 / 0.31	25 / 1	25 / 1	25-30 / 1-1.25	XP254SQZ8*PA	XP254SRZ8*PA
Z10	71,6 / 2.82	82,5 / 3.25	8 / 0.31	25 / 1	40 / 1.5	25-30 / 1-1.25	XP254SQZ10*PA	XP254SRZ10*PA
Z12	89,0 / 3.50	99,5 / 3.92	8 / 0.31	25 / 1	40 / 1.5	25-30 / 1-1.25	XP254SQZ12*PA	XP254SRZ12*PA
Z15	114,0 / 4.49	124,0 / 4.88	8 / 0.31	25 / 1	40-60 / 1.5-2.5	25-30 / 1-1.25	XP254SQZ15*PA	XP254SRZ15*PA
Z18	136,4 / 5.37	146,4 / 5.76	8 / 0.31	25 / 1	40-60 / 1.5-2.5	25-30 / 1-1.25	XP254SQZ18*PA	XP254SRZ18*PA

*Other sprockets and hub sizes are manufactured up to request. *POM (Acetal) and PP (Polypropylene) sprockets raw material is available on request.

***Machined Split Sprockets are available for each size.**



Clamp



Machined Split Sprocket

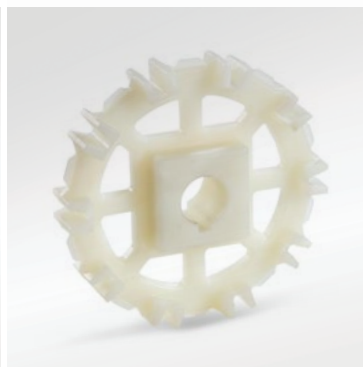

Moulded Sprocket

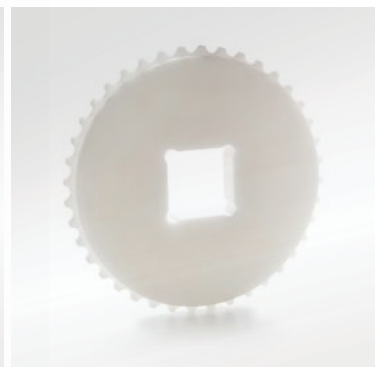

Machined Sprocket



XP254 Series Accessories and Technical Specifications

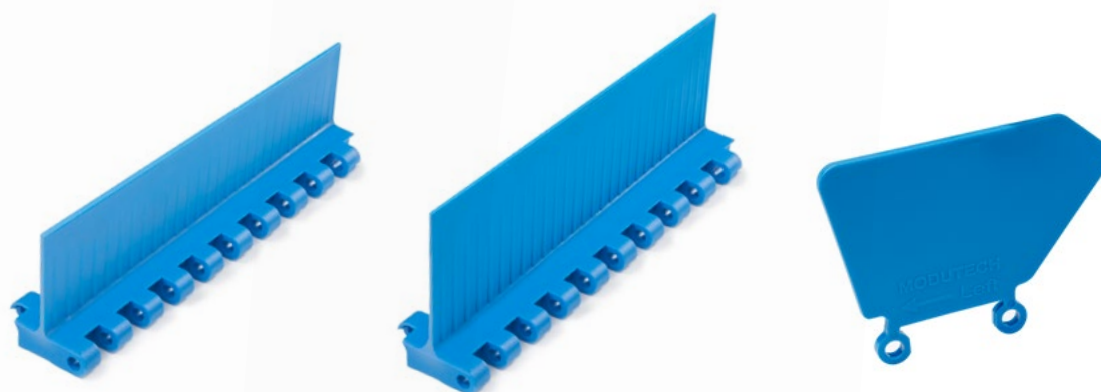

XP254 Series / Flight & Sidewall Dimensions

XP254 Series / Flights & Sidewalls				
PRODUCT CODE	Flight Height (mm/ <i>inch</i>)	Flight Width (mm/ <i>inch</i>)	PRODUCT CODE	Sidewall Height (mm/ <i>inch</i>)
XP254T25	25 / 1	152,4 / 6	XP254SW25	25 / 1
XP254T50	50 / 2	152,4 / 6	XP254SW50	50 / 2
XP254T75	75 / 3	152,4 / 6	XP254SW75	75 / 3
XP254T100	100 / 4	152,4 / 6	XP254SW100	100 / 4

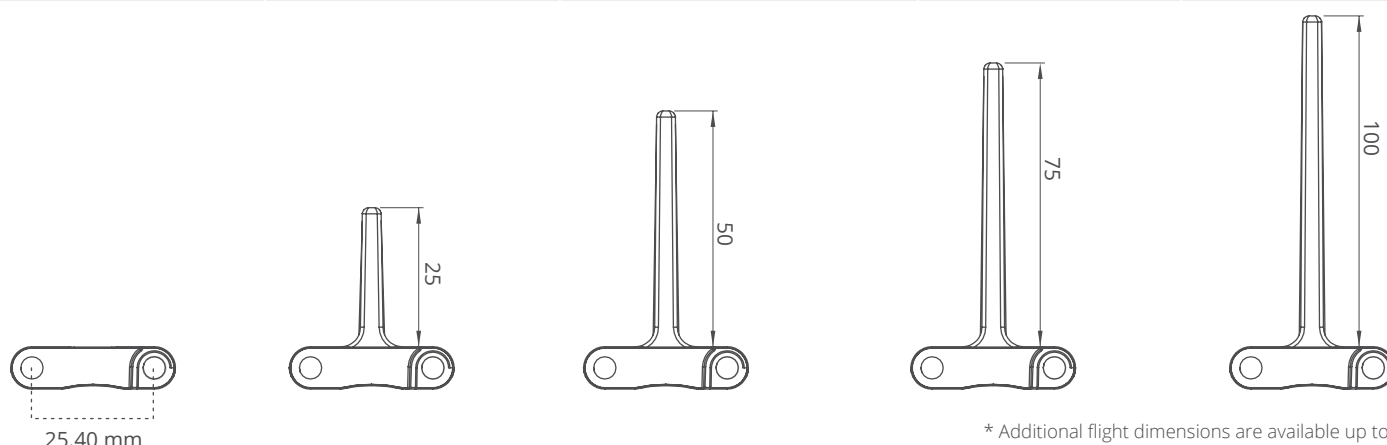

* Additional flight dimensions are available up to 75 mm.

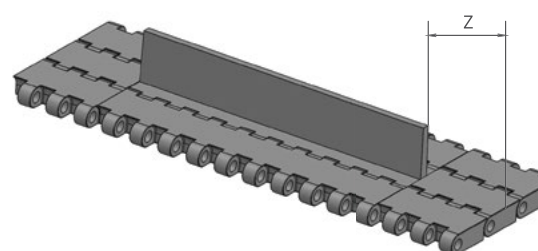
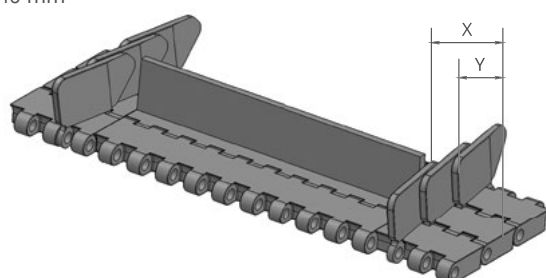

XP254 Series / Sidewall Technical Specifications

Possible Sidewall and Flight Indents	X		Y	
	mm	<i>inch</i>	mm	<i>inch</i>
Standard, no module cutting	24,0	0.94	15,0	0.59
Module cutting necessary	32,0	1.26	22,0	0.87
Standard, no module cutting	40,0	1.57	30,0	1.18
Module cutting necessary	48,0	1.89	37,0	1.46
Standard, no module cutting	56,0	2.20	45,0	1.77
Module cutting necessary	64,0	2.52	53,0	2.09

XP254 Series / Flight Technical Specifications

Possible Flight Indents for XP254 Series	Z	
	mm	<i>inch</i>
Standard, module cutting	15,0	0.59
Standard, no module cutting	30,0	1.18
Standard, no module cutting	45,0	1.77
Standard, module cutting	60,0	2.36
Standard, no module cutting	76,0	2.99

*Non-standard flight indent is on request.

Note: Gap between flight and sidewall minimum 2-3 mm

XP254 Series *Engineering Information*

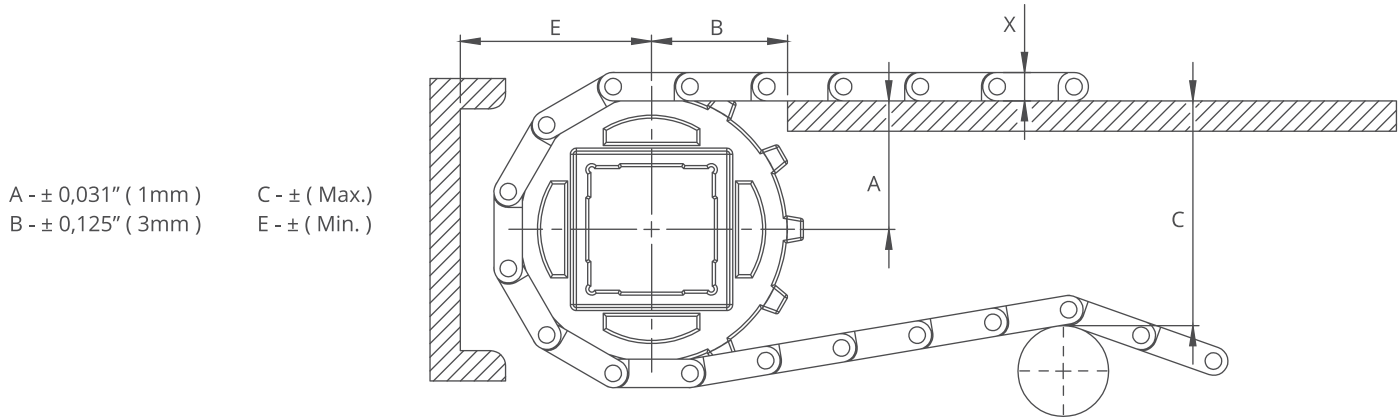

A - $\pm 0,031''$ (1mm)
 B - $\pm 0,125''$ (3mm)
 C - \pm (Max.)
 E - \pm (Min.)

XP254 Series / Conveyor Frame Dimensions

Sprockets Description			A		B		C		E		X	
Pitch Diameter		No.Teeth	Range (Bottom to Top)		inch	mm	inch	mm	inch	mm	inch	mm
inch	mm		inch	mm								
XP254 FLT CR, XP254 C, XP254 FG, XP254 PR%22												
2.32	59,0	8	1.17	29,8	1.44	36,5	1.94	49,3	1.91	48,6	0.35	8,8
2.99	76,0	10	1.47	37,0	1.69	42,9	2.57	65,4	2.21	56,2	0.35	8,8
3.59	91,2	12	1.79	45,5	1.86	47,3	3.19	81,1	2.53	64,3	0.35	8,8
4.65	118,0	15	2.22	56,3	2.13	54,1	4.15	105,3	2.96	75,1	0.35	8,8
5.67	144,0	18	2.71	69,0	2.31	58,7	5.16	131,0	3.45	87,8	0.35	8,8
XP254 CR												
2.32	59,0	8	1.17	29,8	1.44	36,5	1.94	49,3	1.91	48,6	0.37	9,3
2.99	76,0	10	1.47	37,0	1.69	42,9	2.57	65,4	2.21	56,2	0.37	9,3
3.59	91,2	12	1.79	45,5	1.86	47,3	3.19	81,1	2.53	64,3	0.37	9,3
4.65	118,0	15	2.22	56,3	2.13	54,1	4.15	105,3	2.96	75,1	0.37	9,3
5.67	144,0	18	2.71	69,0	2.31	58,7	5.16	131,0	3.45	87,8	0.37	9,3

XP254 Series / Slider Support System For Straight Running Belts

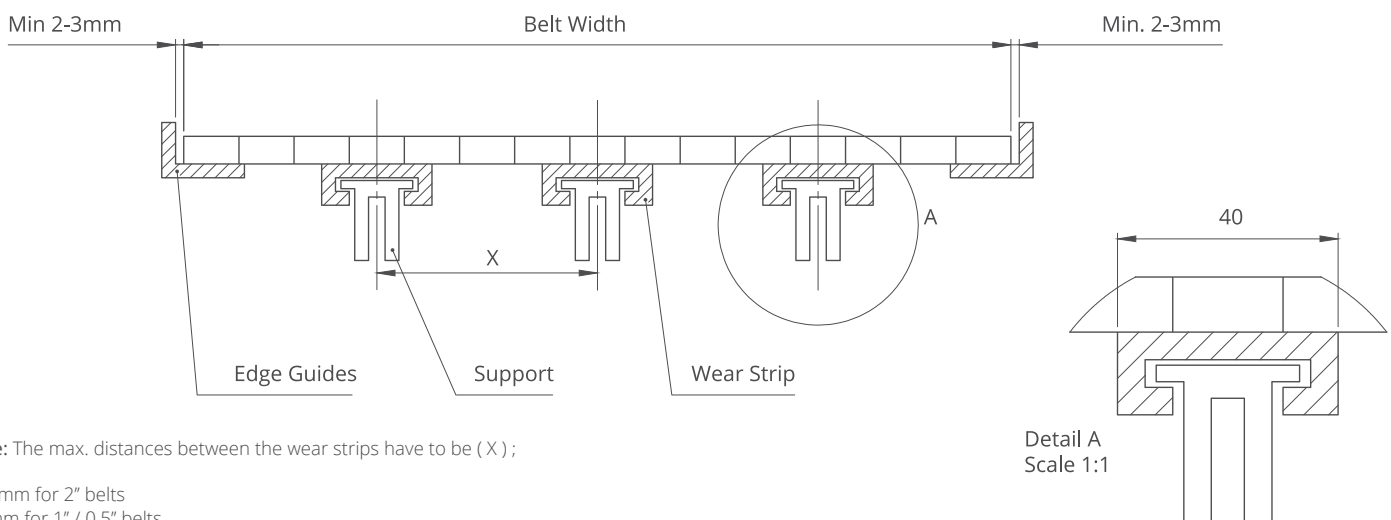

Note: The max. distances between the wear strips have to be (X) ;

125 mm for 2" belts
 80 mm for 1" / 0.5" belts

Detail A
 Scale 1:1

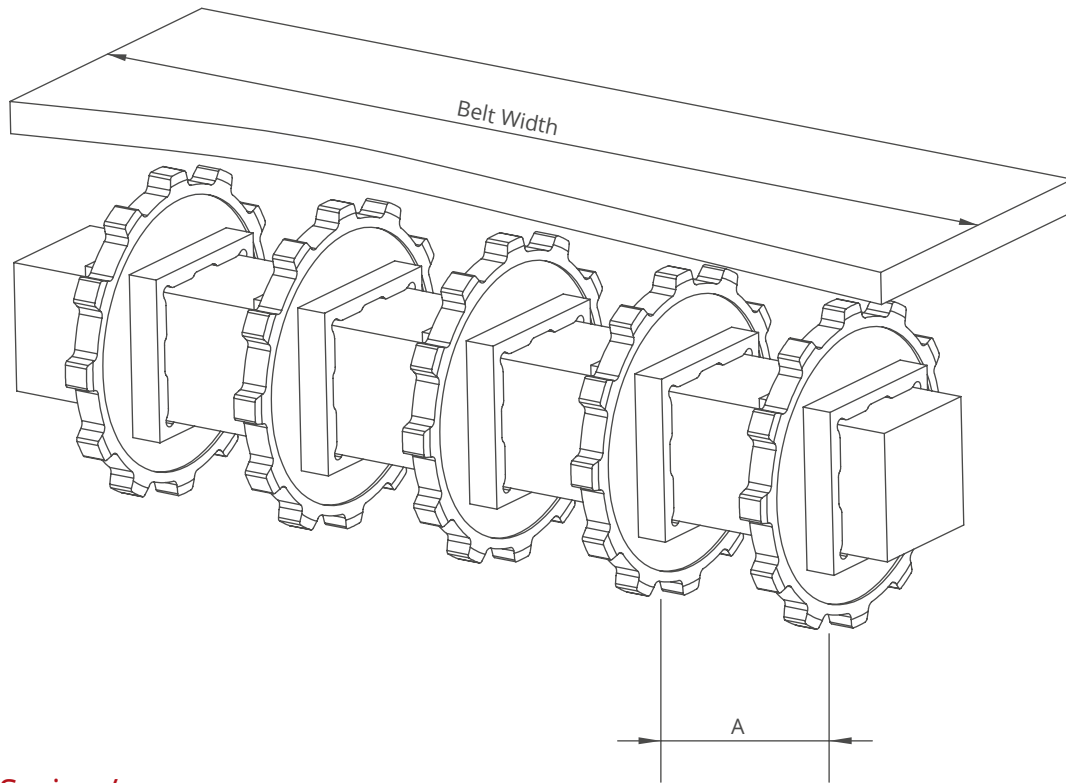

XP254 Series / Sprockets Arrangement

Standard Belt Width		Number of sprockets per shaft		A (mm/inch)	
mm	inch	Drive Shaft	Return Shaft	Min.	Max.
152,4	6.0	2	2	60/2.36	170/6.6
228,6	9.0	2	2	60/2.36	170/6.6
304,8	12.0	3	2	60/2.36	170/6.6
381,0	15.0	4	3	60/2.36	170/6.6
457,2	18.0	5	3	60/2.36	170/6.6
533,4	21.0	5	3	60/2.36	170/6.6
609,6	24.0	6	3	60/2.36	170/6.6
685,8	27.0	6	4	60/2.36	170/6.6
762,0	30.0	7	4	60/2.36	170/6.6
838,2	33.0	7	4	60/2.36	170/6.6
914,4	36.0	8	4	60/2.36	170/6.6
990,6	39.0	8	5	60/2.36	170/6.6
1066,8	42.0	9	5	60/2.36	170/6.6
1143,0	45.0	9	5	60/2.36	170/6.6
1219,2	48.0	10	5	60/2.36	170/6.6
1295,4	51.0	10	6	60/2.36	170/6.6
1371,6	54.0	11	7	60/2.36	170/6.6
1447,8	57.0	11	7	60/2.36	170/6.6
1524,0	60.0	12	7	60/2.36	170/6.6
1600,2	63.0	12	8	60/2.36	170/6.6
1676,4	66.0	12	8	60/2.36	170/6.6
1752,6	69.0	13	8	60/2.36	170/6.6
1828,8	72.0	14	9	60/2.36	170/6.6
1905,0	75.0	14	9	60/2.36	170/6.6
1981,2	78.0	15	10	60/2.36	170/6.6
2057,4	81.0	15	10	60/2.36	170/6.6

Note: Number of sprockets depends on the belt load.

EC254

Modular Belt Series

EC254 C

EC254 PR%16

EC254 NT

Sprockets & Accessories

Engineering Information

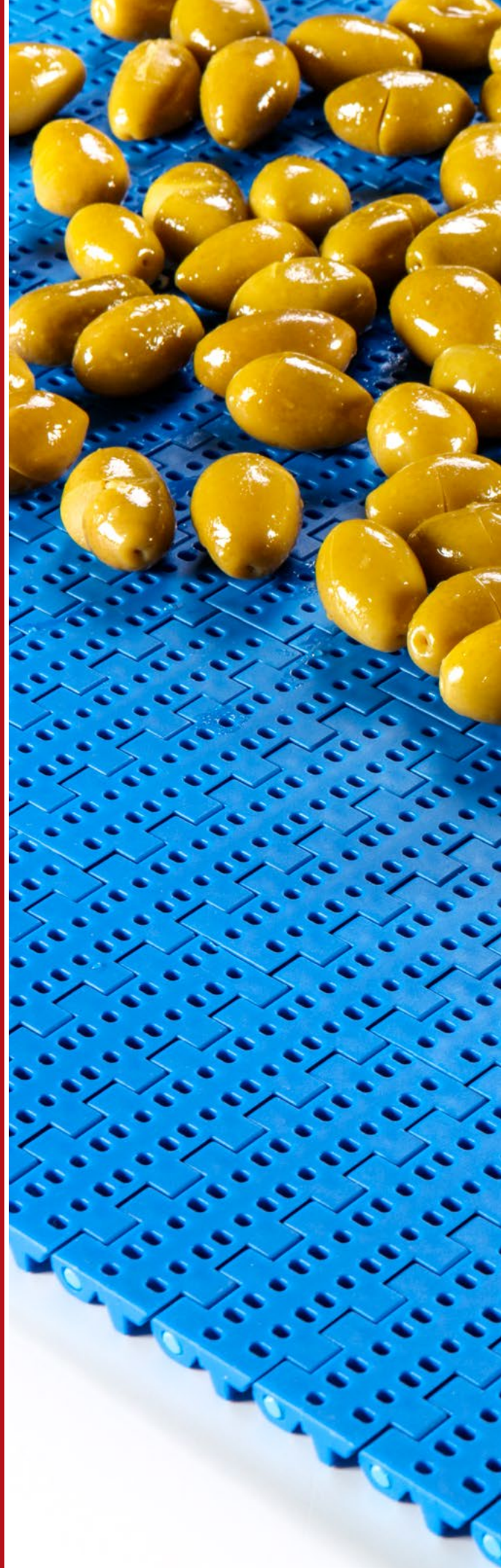





EC254 C

Modular Belt Series

- **Meat (Beef and Pork) Applications**

Fat - Trim Lines, General Conveyence, Packing Lines, Elevator

- **Poultry Applications**

Debonning, Trim Lines, Offal - Feather Lines, Grading Lines, Freezing Lines, Elevator

- **Seafood Applications**

Inspection Tables, Grading Lines, Trim Lines

- **Bakery Applications**

Row Dough Handling, Cooling Lines, Packing Lines

- **Snack Food Applications**

Corn Processing

- **Fruits and Vegetables Applications**

Bulk Feeding, Elevator, Control - Sorting Table

- **Packaging Applications**

Labelling, Palletizing - Depalletizing



EC254 C

Pitch:	25,4 mm / 1 inch
Belt Surface:	Close, Smooth Surface
Minimum Width:	152,4 mm / 6 inch
Open Area (%):	0%
Flight:	Yes (T25, T50, T75, TC75, TCH75, T100, TNC50, TNC100)
Sidewall:	Yes (h=25 mm, h=50 mm, h=75 mm, h=100 mm)
Rod:	Ø5 mm / 0.197 inch - Self Lock
Approved:	FDA and EU
Curve:	No
Color:	Additional colors available
Cleanability:	Excellent
Belt Thickness:	10 mm / 0.394 inch



Product Features and Functional Benefits

- Easy to clean reduces downtime for cleaning time 70%.
- Unique sprocket engagement - higher product load and longer conveyors.
- Close transfer applications.
- Reduces bacteria growth.

Available Moulded Module Sizes

- 152,4 mm / **6 inch** module
- 76,2 mm / **3 inch** module
- 45 mm / **1.77 inch** module
- 30 mm / **1.18 inch** module

EC254 C / Technical Information

BELT MATERIAL	BELT STRENGTH				TEMPERATURE		BELT WEIGHT
	Straight		Curve		°C / °F (min.)	°C / °F (max.)	Kg/m ² / lb/ft ²
	N/m	lb/ft	N/m	lb/ft			
Polypropylene	15400	1055	-	-	+5 / +41	+90 / +194	4,9 / 1.00
Polyethylene	9240	603	-	-	-73 / -99.4	+66 / +150.8	5,2 / 1.05
Acetal	25150	1723	-	-	-43 / -45.4	+110 / +230	7,3 / 1.49

- Belt strength and temperature values are maximum on the table.

EC254 C / Standard Belt Widths

BELT SERIES	WIDTH (W)				Belt With Tolerance (max.)
	PP-PE		POM		
	mm	inch	mm	inch	
EC254 C	152,4	6.0	152,4	6.0	± 0,5 mm
EC254 C	228,6	9.0	228,6	9.0	± 2 mm
EC254 C	304,8	12.0	304,8	12.0	± 2 mm
EC254 C	381,0	15.0	381,0	15.0	± 3 mm
EC254 C	457,2	18.0	457,2	18.0	± 3 mm
EC254 C	533,4	21.0	533,4	21.0	± 3 mm
EC254 C	609,6	24.0	609,6	24.0	± 3 mm
EC254 C	685,8	27.0	685,8	27.0	± 4 mm
EC254 C	762,0	30.0	762,0	30.0	± 4 mm
EC254 C	838,2	33.0	838,2	33.0	± 4 mm
EC254 C	914,4	36.0	914,4	36.0	± 4 mm
EC254 C	990,6	39.0	990,6	39.0	± 4 mm
EC254 C	1066,8	42.0	1066,8	42.0	± 4 mm
EC254 C	1143,0	45.0	1143,0	45.0	± 4 mm

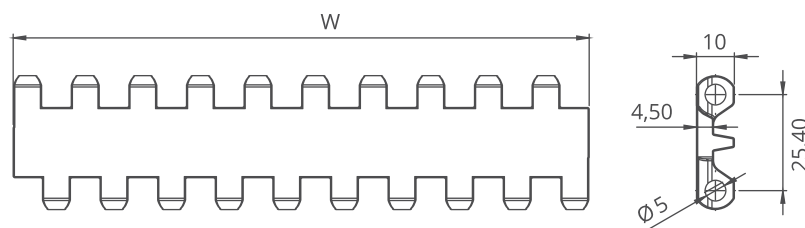

- Standard belt increments 76,2 mm.
- Non-standard belt increments 15,2 mm.
- Please contact with customer service for precise belt measurements.



EC254 PR%16

Modular Belt Series

• Meat and Poultry Applications

General Conveyance and Breeding Lines

• Fruit and Vegetable Applications

Including Elevators, Steam Peeler, Inspection Tables

• Seafood Applications

Including Elevators, Inspection Tables, Grading Lines,

Trim Lines, Glazing Lines, Cooking Lines

• Bakery Applications

Including Raw Dough Handling, Cooling Lines,

Icing Lines, Packing Lines, Metal Detectors



EC254 PR%16

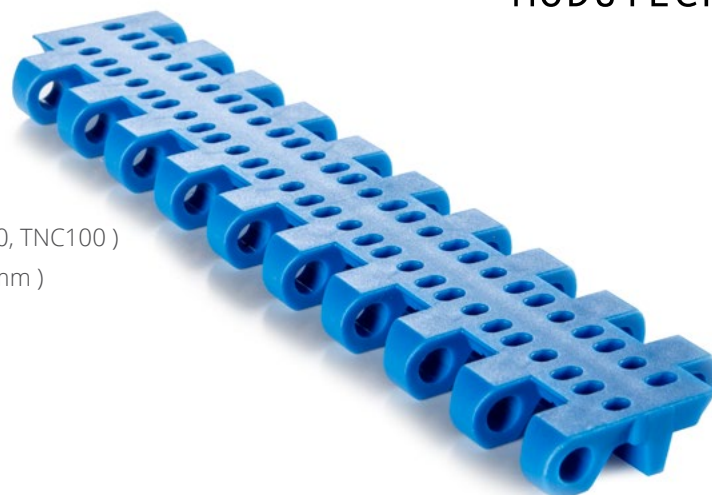

Pitch:	25,4 mm / 1 inch
Belt Surface:	Open, Smooth Surface
Minimum Width:	152,4 mm / 6 inch
Open Area (%):	16%. (Biggest opening 2,5 x 4,5 mm)
Flight:	Yes (T25, T50, T75, TC75, TCH75, T100, TNC50, TNC100)
Sidewall:	Yes (h=25 mm, h=50 mm, h=75 mm, h=100 mm)
Rod:	Ø5 mm / 0.197 inch - Self Lock
Approved:	FDA and EU
Curve:	No
Color:	Additional colors available
Cleanability:	Excellent
Belt Thickness:	10 mm / 0.394 inch

Product Features and Functional Benefits

- Unique sprocket engagement - precise indexing, easy cleaning.
- Different openings to optimize performance in cooling and draining applications.
- Easy to clean reduces downtime for cleaning time 70%.
- Reduces bacteria growth.

Available Moulded Module Sizes

- 152,4 mm / **6 inch** module
- 76,2 mm / **3 inch** module
- 45 mm / **1.77 inch** module
- 30 mm / **1.18 inch** module

EC254 PR%16 / Technical Information

BELT MATERIAL	BELT STRENGTH				TEMPERATURE		BELT WEIGHT
	Straight		Curve		°C / °F (min.)	°C / °F (max.)	
	N/m	lb/ft	N/m	lb/ft			Kg/m ² / lb/ft ²
Polypropylene	12100	828	-	-	+5 / +41	+90 / +194	4,5 / 0.92
Polyethylene	7700	527	-	-	-73 / -99.4	+66 / +150.8	4,7 / 0.96
Acetal	19800	1356	-	-	-43 / -45.4	+110 / +230	6,5 / 1.33

- Belt strength and temperature values are maximum on the table.

EC254 PR%16 / Standard Belt Widths

BELT SERIES	WIDTH (W)				Belt With Tolerance (max.)
	PP-PE		POM		
	mm	inch	mm	inch	
EC254 PR16	152,4	6.0	152,4	6.0	± 0,5 mm
EC254 PR16	228,6	9.0	228,6	9.0	± 2 mm
EC254 PR16	304,8	12.0	304,8	12.0	± 2 mm
EC254 PR16	381,0	15.0	381,0	15.0	± 3 mm
EC254 PR16	457,2	18.0	457,2	18.0	± 3 mm
EC254 PR16	533,4	21.0	533,4	21.0	± 3 mm
EC254 PR16	609,6	24.0	609,6	24.0	± 3 mm
EC254 PR16	685,8	27.0	685,8	27.0	± 4 mm
EC254 PR16	762,0	30.0	762,0	30.0	± 4 mm
EC254 PR16	838,2	33.0	838,2	33.0	± 4 mm
EC254 PR16	914,4	36.0	914,4	36.0	± 4 mm
EC254 PR16	990,6	39.0	990,6	39.0	± 4 mm
EC254 PR16	1066,8	42.0	1066,8	42.0	± 4 mm
EC254 PR16	1143,0	45.0	1143,0	45.0	± 4 mm

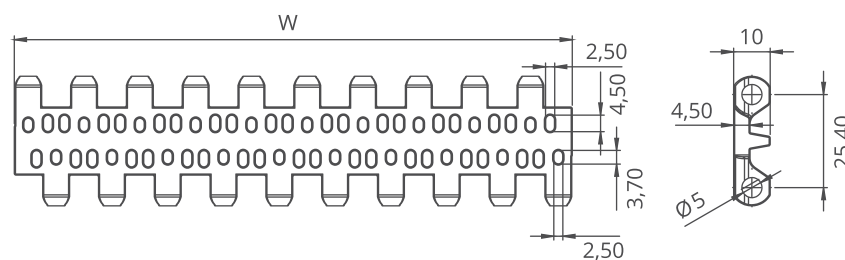

- Standard belt increments 76,2 mm.
- Non standard belt increments 15,2 mm.
- Please contact with customer service for precise belt measurements.



EC254 NT

Modular Belt Series

• Meat (Beef and Pork) Applications

Elevator

• Poultry Applications

Elevator, Freezing Lines

• Seafood Applications

Control Tables, Glazing

• Fruits and Vegetables

Including Elevator



EC254 NT

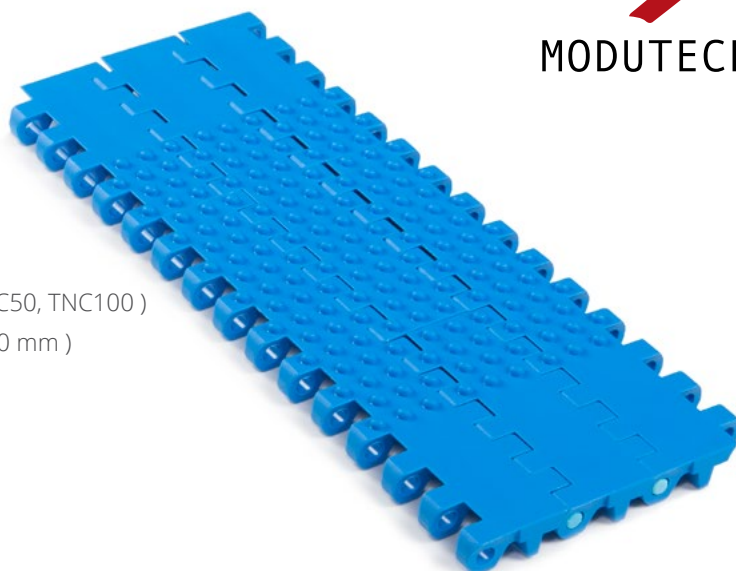

Pitch:	25,4 mm / 1 inch
Belt Surface:	Close, Nub Top Surface
Minimum Width:	152,4 mm / 6 inch
Open Area (%):	0%
Flight:	Yes (T25, T50, T75, TC75, TCH75, T100, TNC50, TNC100)
Sidewall:	Yes (h=25 mm, h=50 mm, h=75 mm, h=100 mm)
Rod:	Ø5 mm / 0.197 inch - Self Lock
Approved:	FDA and EU
Curve:	No
Color:	Additional colors available
Cleanability:	Excellent
Belt Thickness:	12 mm / 0.472 inch

Product Features and Functional Benefits

- Easy to clean reduces downtime for cleaning time 70%.
- Reduces bacteria growth.
- Non-adhesive due to reduced contact surface.
- Close transfer applications.

Available Moulded Module Sizes

- 152,4 mm / **6 inch** module
- 152,4 mm / **6 inch** edge module with 45 mm indent

EC254 NT / Technical Information

BELT MATERIAL	BELT STRENGTH				TEMPERATURE		BELT WEIGHT
	Straight		Curve		°C / °F (min.)	°C / °F (max.)	
	N/m	lb/ft	N/m	lb/ft			Kg/m ² / lb/ft ²
Polypropylene	15400	1055	-	-	+5 / +41	+90 / +194	5,1 / 1.05
Polyethylene	8800	603	-	-	-73 / -99.4	+66 / +150.8	5,4 / 1.11
Acetal	25150	1723	-	-	-43 / -45.4	+110 / +230	7,7 / 1.57

- Belt strength and temperature values are maximum on the table.

EC254 NT / Standard Belt Widths

BELT SERIES	WIDTH (W)				Belt With Tolerance (max.)
	PP-PE		POM		
	mm	inch	mm	inch	
EC254 NT	152,4	6.0	152,4	6.0	± 0,5 mm
EC254 NT	228,6	9.0	228,6	9.0	± 2 mm
EC254 NT	304,8	12.0	304,8	12.0	± 2 mm
EC254 NT	381,0	15.0	381,0	15.0	± 3 mm
EC254 NT	457,2	18.0	457,2	18.0	± 3 mm
EC254 NT	533,4	21.0	533,4	21.0	± 3 mm
EC254 NT	609,6	24.0	609,6	24.0	± 3 mm
EC254 NT	685,8	27.0	685,8	27.0	± 4 mm
EC254 NT	762,0	30.0	762,0	30.0	± 4 mm
EC254 NT	838,2	33.0	838,2	33.0	± 4 mm
EC254 NT	914,4	36.0	914,4	36.0	± 4 mm
EC254 NT	990,6	39.0	990,6	39.0	± 4 mm
EC254 NT	1066,8	42.0	1066,8	42.0	± 4 mm
EC254 NT	1143,0	45.0	1143,0	45.0	± 4 mm

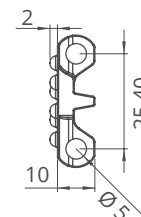
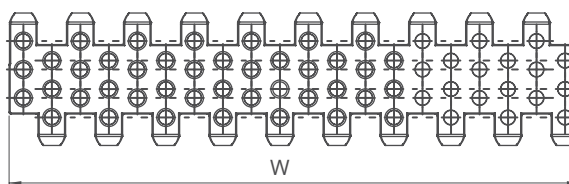

- Standard belt increments 76,2 mm.
- Non-standard belt increments 15,2 mm.
- Please contact with customer service for precise belt measurements.

EC254 Series Sprockets and Technical Specifications



Z15



Z15

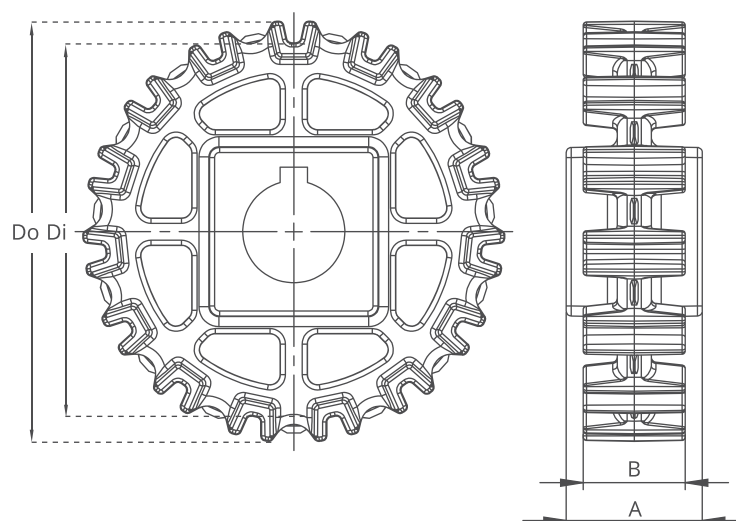
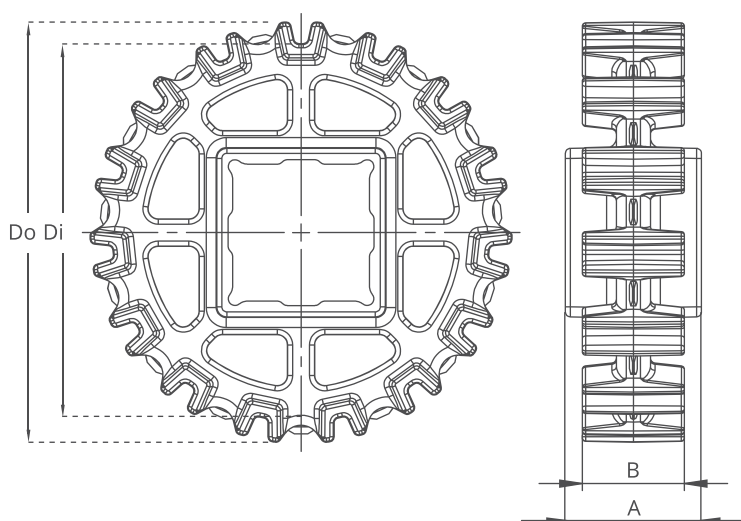

EC254 Series / Standard Sprockets Dimensions

NO. TEETH	Di mm/inch	Do mm/inch	B mm/inch	A mm/inch	Square Bore (Q) mm/inch	Round Bore (R) mm/inch	PRODUCT CODE	
							Square Type (Q)	Round Type (R)
Z8	51,6 / 2.03	64,6 / 2.54	30 / 1.18	40 / 1.57	25 / 1	25 / 1	EC254SQZ8*POM	EC254SRZ8*POM
Z10	68,8 / 2.71	81,8 / 3.22	30 / 1.18	40 / 1.57	40 / 1.5	25-30 / 1-1.25	EC254SQZ10*POM	EC254SRZ10*POM
Z12	85,5 / 3.37	98,8 / 3.89	30 / 1.18	40 / 1.57	40 / 1.5	25-30 / 1-1.25	EC254SQZ12*POM	EC254SRZ12*POM
Z15	111,1 / 4.37	124,1 / 4.89	30 / 1.18	40 / 1.57	40 / 1.5	25-30 / 1-1.25	EC254SQZ15*POM	EC254SRZ15*POM
Z18	136,1 / 5.36	149,1 / 5.87	30 / 1.18	40 / 1.57	40 / 1.5	25-30 / 1-1.25	EC254SQZ18*POM	EC254SRZ18*POM

*Other sprockets and hub sizes are manufactured up to request. *PA (Polyamide) and PP (Polypropylene) sprockets raw material is available on request.

***Machined Split Sprockets are available for each size.**



Clamp



Machined Split Sprocket

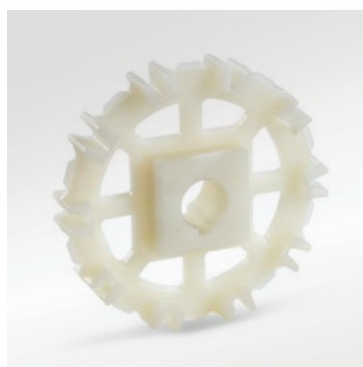

Moulded Sprocket

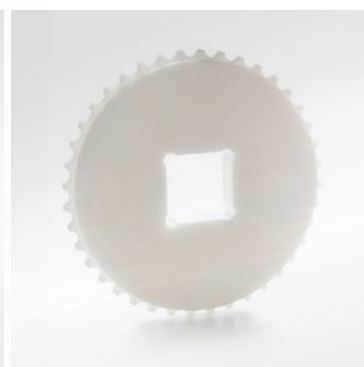

Machined Sprocket



EC254 Series Accessories and Technical Specifications

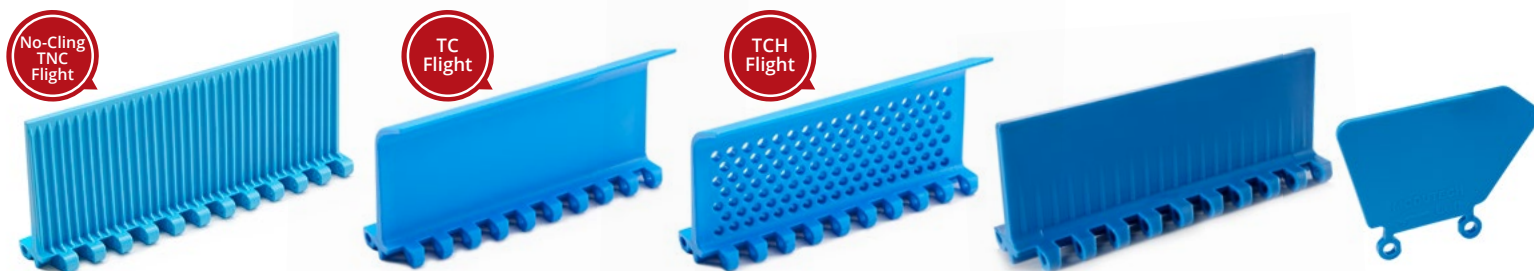

EC254 Series / Flight & Sidewall Dimensions

EC254 Series / Flights & Sidewalls				
PRODUCT CODE	Flight Height (mm/ inch)	Flight Width (mm/ inch)	PRODUCT CODE	Sidewall Height (mm/ inch)
EC254T25	25 / 1	152,4 / 6	EC254SW25	25 / 1
EC254T50	50 / 2	152,4 / 6	EC254SW50	50 / 2
EC254T75	75 / 3	152,4 / 6	EC254SW75	75 / 3
EC254T100	100 / 4	152,4 / 6	EC254SW100	100 / 4
EC254TC75	75 / 3	152,4 / 6	-	-
EC254TCH75	75 / 3	152,4 / 6	-	-
EC254TNC50	50 / 2	152,4 / 6	-	-
EC254TNC100	100 / 4	152,4 / 6	-	-

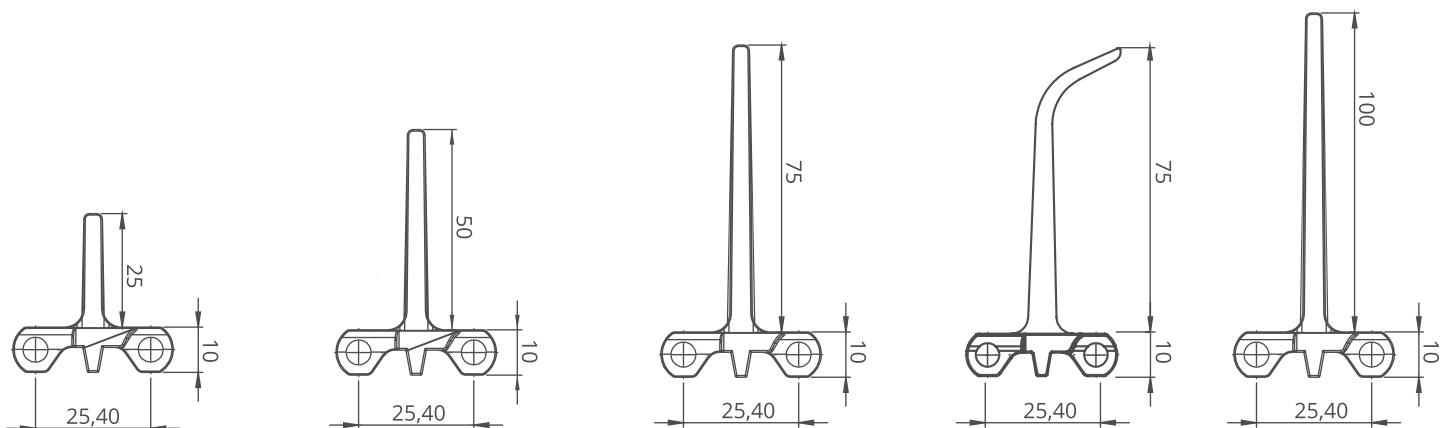

* Additional flight dimensions are available up to 100 mm.

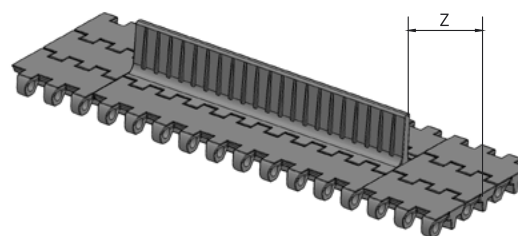
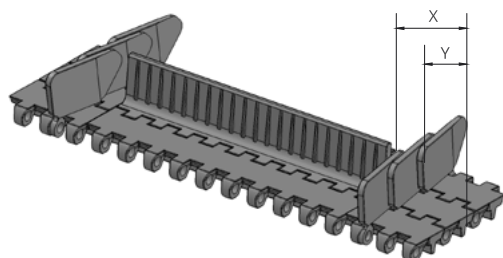

EC254 Series / Sidewall Technical Specifications

Possible Sidewall and Flight Indents	X		Y	
	mm	inch	mm	inch
Standard, no module cutting	24,0	0.94	15,0	0.59
Module cutting necessary	32,0	1.26	22,0	0.87
Standard, no module cutting	40,0	1.57	30,0	1.18
Module cutting necessary	48,0	1.89	37,0	1.46
Standard, no module cutting	56,0	2.20	45,0	1.77
Module cutting necessary	64,0	2.52	53,0	2.09

EC254 Series / Flight Technical Specifications

Possible Flight Indents for EC254 Series	Z	
	mm	inch
Standard, module cutting	15,0	0.59
Standard, no module cutting	30,0	1.18
Standard, no module cutting	45,0	1.77
Standard, module cutting	60,0	2.36
Standard, no module cutting	76,0	2.99

*Non-standard flight indent is on request.

Note: Gap between flight and sidewall minimum 2-3 mm
Gap between flight and sidewall maximum 10 mm

EC254 Series *Engineering Information*

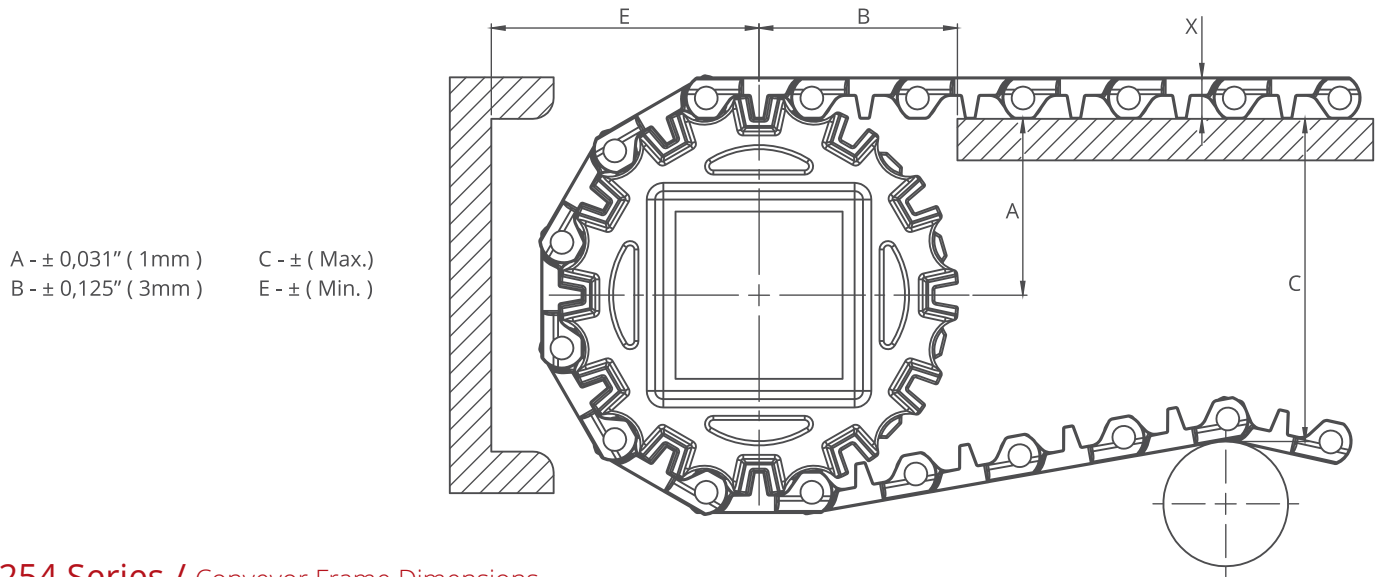

A - $\pm 0,031''$ (1mm) C - \pm (Max.)
 B - $\pm 0,125''$ (3mm) E - \pm (Min.)

EC254 Series / Conveyor Frame Dimensions

Sprockets Description			A		B		C		E		X	
Pitch Diameter		No.Teeth	Range (Bottom to Top)		inch	mm	inch	mm	inch	mm	inch	mm
inch	mm		inch	mm								
EC254 C, EC254 PR%16												
2.30	58,5	8	1.16	29,4	1.48	37,6	1.92	48,7	1.94	49,4	0.39	10,0
2.97	75,5	10	1.48	37,5	1.69	42,9	2.57	65,3	2.26	57,5	0.39	10,0
3.63	92,3	12	1.80	45,8	1.87	47,4	3.23	82,0	2.59	65,8	0.39	10,0
4.65	118,0	15	2.23	56,7	2.16	54,9	4.16	105,7	3.02	76,7	0.39	10,0
5.63	143,0	18	2.75	70,0	2.35	59,7	5.18	131,5	3.54	90,0	0.39	10,0
EC254 NT												
2.30	58,5	8	1.08	27,4	1.52	38,6	1.84	46,7	1.94	49,4	0.47	12,0
2.97	75,5	10	1.40	35,5	1.74	44,1	2.49	63,3	2.26	57,5	0.47	12,0
3.63	92,3	12	1.74	44,1	1.92	48,7	3.16	80,3	2.60	66,1	0.47	12,0
4.65	118,0	15	2.20	55,9	2.19	55,5	4.13	109,0	3.07	77,9	0.47	12,0
5.63	143,0	18	2.70	68,6	2.40	61,0	4.20	120,0	2.95	91,0	0.47	12,0

EC254 Series / Slider Support System For Straight Running Belts

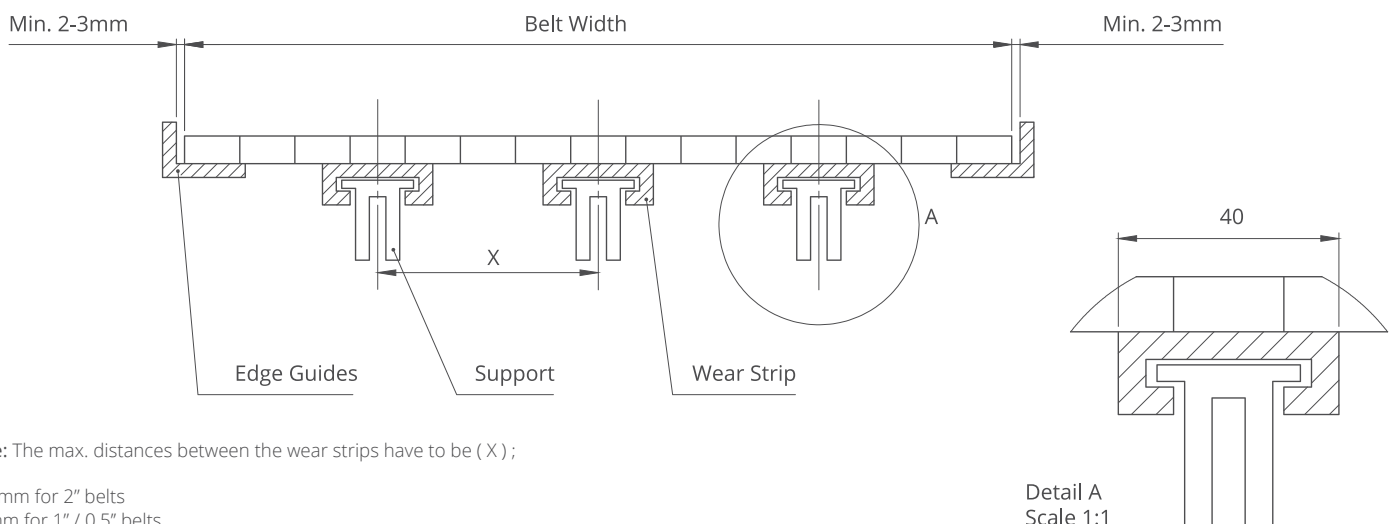

Note: The max. distances between the wear strips have to be (X) ;

125 mm for 2" belts
 80 mm for 1" / 0.5" belts

Detail A
 Scale 1:1

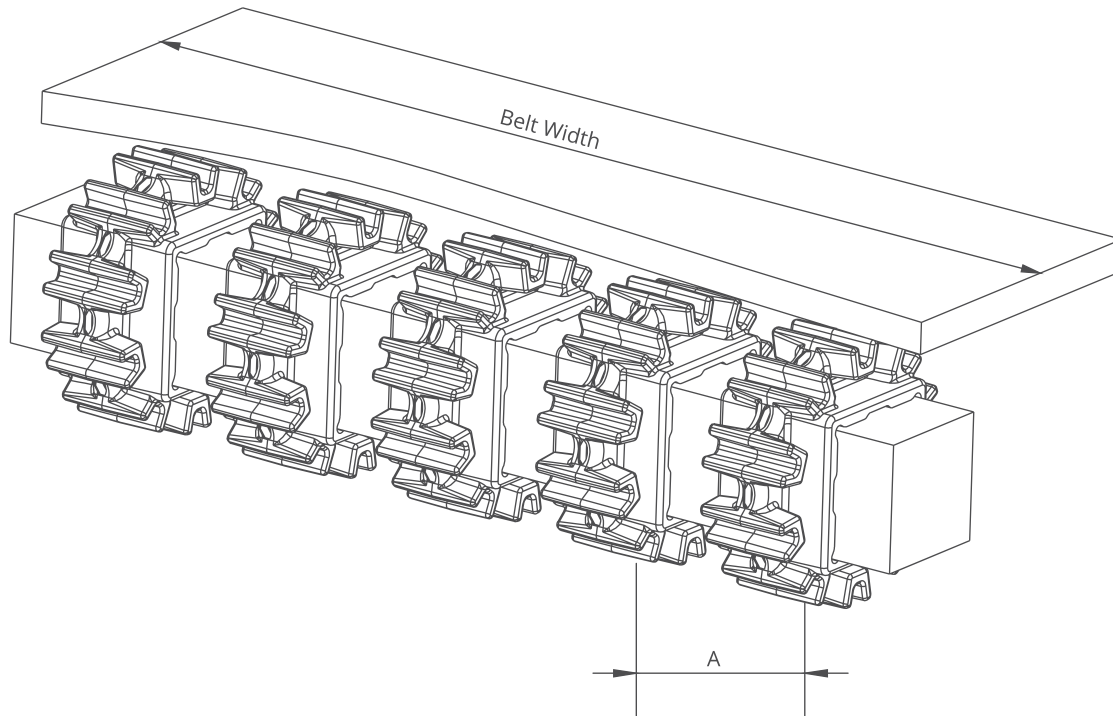

EC254 Series / Sprockets Arrangement

Standard Belt Width		Number of sprockets per shaft		A (mm/inch)	
mm	inch	Drive Shaft	Return Shaft	Min.	Max.
152,4	6.0	2	2	60/2.36	170/6.6
228,6	9.0	2	2	60/2.36	170/6.6
304,8	12.0	3	2	60/2.36	170/6.6
381,0	15.0	4	3	60/2.36	170/6.6
457,2	18.0	5	3	60/2.36	170/6.6
533,4	21.0	5	3	60/2.36	170/6.6
609,6	24.0	6	3	60/2.36	170/6.6
685,8	27.0	6	4	60/2.36	170/6.6
762,0	30.0	7	4	60/2.36	170/6.6
838,2	33.0	7	4	60/2.36	170/6.6
914,4	36.0	8	4	60/2.36	170/6.6
990,6	39.0	8	5	60/2.36	170/6.6
1066,8	42.0	9	5	60/2.36	170/6.6
1143,0	45.0	9	5	60/2.36	170/6.6
1219,2	48.0	10	5	60/2.36	170/6.6
1295,4	51.0	10	6	60/2.36	170/6.6
1371,6	54.0	11	7	60/2.36	170/6.6
1447,8	57.0	11	7	60/2.36	170/6.6
1524,0	60.0	12	7	60/2.36	170/6.6
1600,2	63.0	12	8	60/2.36	170/6.6
1676,4	66.0	12	8	60/2.36	170/6.6
1752,6	69.0	13	8	60/2.36	170/6.6
1828,8	72.0	14	9	60/2.36	170/6.6
1905,0	75.0	14	9	60/2.36	170/6.6
1981,2	78.0	15	10	60/2.36	170/6.6
2057,4	81.0	15	10	60/2.36	170/6.6

Note: Number of sprockets depends on the belt load.

MD254

Modular Belt Series

MD254 FG

MD254 C

MD254 GT / Friction Top

MD254 RR

Sprockets & Accessories

Engineering Information

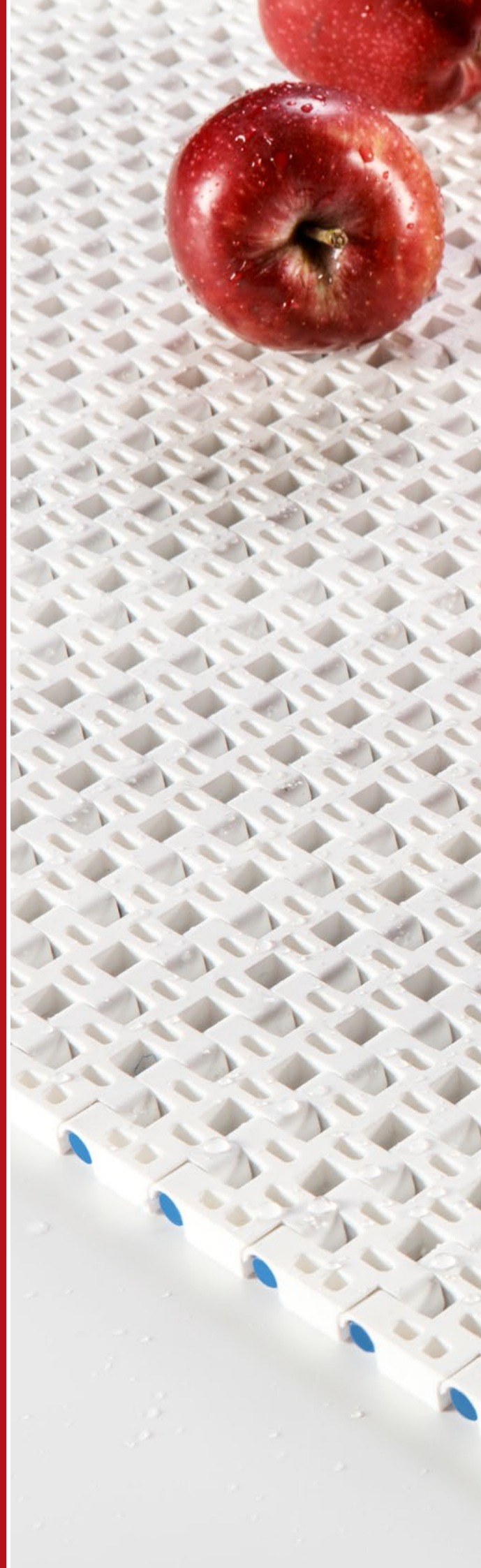





MD254 FG

Modular Belt Series

- **Bakery Applications**

Oven Infeed - Outfeed, Cooling Lines, Coating Lines, Glazing Lines, Freezing Lines, Conditioning Lines

- **Poultry Applications**

Skinning, Breeding Machines and Grading Lines

- **Seafood Applications**

Breeding Machines, Draining Lines, Glazing Lines, Elevators, Freezing Lines

- **Snack Food Applications**

Proofer Lines, Boiler Infeed, Oven Infeed - Outfeed, Cooling Lines

- **Fruits and Vegetables Applications**

Prewashing - Rinsing, Draining, Blanching Lines, Elevators

- **Packaging Applications**

Filling, Accumulation Palletizing - Depalletizing, Box Transfer

- **Textile Applications**

Cutter, Dyeing



MD254 FG



Pitch:	25,4 mm / 1 inch
Belt Surface:	Open, Smooth Surface
Minimum Width:	50 mm / 1.97 inch
Open Area (%):	33%. (Biggest opening 5,5 x 7 mm)
Flight:	Yes (T25, T50, TC50, TCH50, TNC75, TNC100, T75, T100)
Sidewall:	Yes (h=25mm, h=50mm, h=75mm, h=100mm)
Rod:	Ø 5 mm / 0.197 inch - Self Lock
Approved:	FDA and EU
Curve:	No
Color:	Additional colors available
Cleanability:	Good
Belt Thickness:	10 mm / 0.394 inch

Product Features and Functional Benefits

- Belt provides optimal open area for drainage and airflow.
- Less friction and product contact for easy cooking, cooling and freezing of products.
- Reduced dirt and oxide build due to self cleaning surface.
- Bi-directional belt for long conveyors.
- Stainless steel pins option for high temperature applications.
- Easy to clean reduces downtime for cleaning time 70%.
- Stainless steel pins option reduce belt elongation for high temperature application.

Available Moulded Module Sizes

- 200 mm / **7.87 inch** module
- 100 mm / **3.94 inch** module
- 50 mm / **1.97 inch** module
- 33 mm / **1.30 inch** module

MD254 FG / Technical Information

BELT MATERIAL	BELT STRENGTH				TEMPERATURE		BELT WEIGHT
	Straight		Curve		°C / °F (min.)	°C / °F (max.)	Kg/m ² / lb/ft ²
	N/m	lb/ft	N/m	lb/ft			
Polypropylene	15400	1055	-	-	+5 / +41	+90 / +194	4,6 / 0.94
Polyethylene	8800	603	-	-	-73 / -99.4	+66 / +150.8	5,1 / 1.04
Acetal	27170	1861	-	-	-43 / -45.4	+110 / +230	7,1 / 1.45

- Belt strength and temperature values are maximum on the table.

MD254 FG / Standard Belt Widths

BELT SERIES	WIDTH (W)				Belt With Tolerance (max.)
	PP-PE		POM		
	mm	inch	mm	inch	
MD254 FG	200,0	7.87	200,0	7.87	± 1 mm
MD254 FG	250,0	9.84	250,0	9.84	± 1 mm
MD254 FG	300,0	11.81	300,0	11.81	± 2 mm
MD254 FG	350,0	13.77	350,0	13.77	± 2 mm
MD254 FG	400,0	15.75	400,0	15.75	± 2 mm
MD254 FG	450,0	17.71	450,0	17.71	± 2 mm
MD254 FG	500,0	19.69	500,0	19.69	± 2 mm
MD254 FG	550,0	21.65	550,0	21.65	± 3 mm
MD254 FG	600,0	23.62	600,0	23.62	± 3 mm
MD254 FG	650,0	25.60	650,0	25.60	± 3 mm
MD254 FG	700,0	27.56	700,0	27.56	± 3 mm
MD254 FG	750,0	29.50	750,0	29.50	± 3 mm
MD254 FG	800,0	31.50	800,0	31.50	± 3 mm
MD254 FG	850,0	33.46	850,0	33.46	± 4 mm
MD254 FG	900,0	35.43	900,0	35.43	± 4 mm

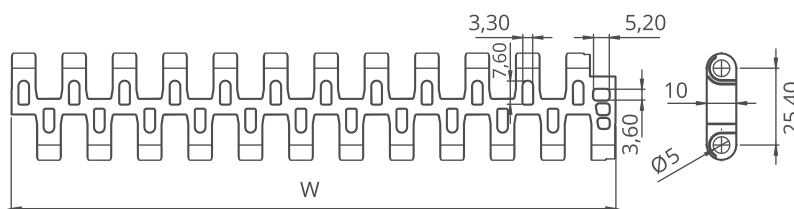

- Standard belt increments 50 mm.
- Non-standard belt increments 16,6 mm.
- Please contact with customer service for precise belt measurements.



MD254 C

Modular Belt Series

- **Meat (Beef and Pork) Applications**

Fat - Trim Lines, General Conveyence, Packing Lines, Elevator

- **Poultry Applications**

Debonning, Trim Lines, Offal - Feather Lines, Grading Lines, Freezing Lines, Elevator

- **Seafood Applications**

Inspection Tables, Grading Lines, Trim Lines

- **Bakery Applications**

Row Dough Handling, Cooling Lines, Packing Lines

- **Snack Food Applications**

Corn Processing

- **Fruits and Vegetables Applications**

Bulk Feeding, Elevator, Control - Sorting Table

- **Automotive Applications**

Car Part Manufacturing

- **Tire Manufacturing Applications**

Mixer Infeed - Outfeed, Calendering Infeed, Extrusion Outfeed

- **Packaging Applications**

Labelling, Case Packers, Tray Packers, Palletizing - Depalletizing

- **Corrugated Cardbord Applications**

Down Stracker, Corrugator Take Off, Strap Feed

- **Printing and Paper Applications**

Printing Machine Outfeed, Wrapping Machine Outfeed

- **Beverages and Botteling Applications**

Can Palletizing and Depalletizing, Glass Palletizing and Depalletizing, Pet Palletizing and Depalletizing

- **Material Handling Applications**

Incline Applications, Palletizers, Packaging Lines



MD254 C

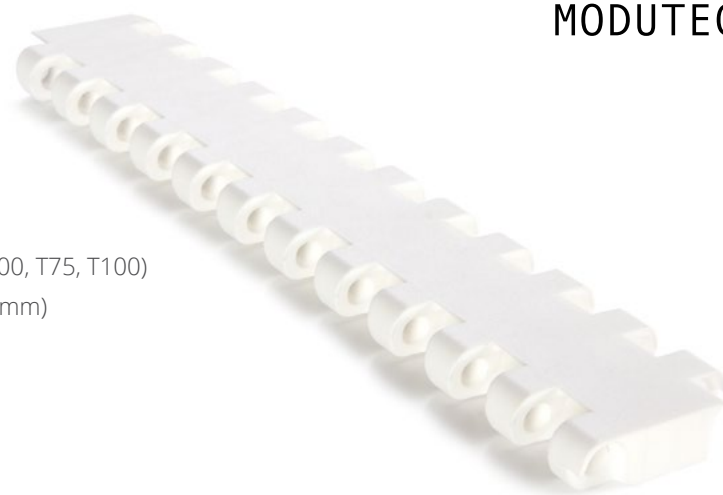

Pitch:	25,4 mm / 1 inch
Belt Surface:	Close, Smooth Surface
Minimum Width:	50 mm / 1.97 inch
Open Area (%):	0%
Flight:	Yes (T25, T50, TC50, TCH50, TNC75, TNC100, T75, T100)
Sidewall:	Yes (h=25mm, h=50mm, h=75mm, h=100mm)
Rod:	Ø 5 mm / 0.197 inch - Self Lock
Approved:	FDA and EU
Curve:	No
Color:	Additional colors available
Cleanability:	Good
Belt Thickness:	10 mm / 0.394 inch

Product Features and Functional Benefits

- Easy to clean reduces downtime for cleaning time 70%.
- Unique sprocket engagement - higher product load and longer conveyors.
- Close transfer applications.
- Reduces bacteria growth.
- Bi-directional belt for long conveyors.

Available Moulded Module Sizes

- 200 mm / **7.87 inch** module
- 100 mm / **3.94 inch** module
- 50 mm / **1.97 inch** module
- 33 mm / **1.30 inch** module

MD254 C / Technical Information

BELT MATERIAL	BELT STRENGTH				TEMPERATURE		BELT WEIGHT
	Straight		Curve		°C / °F (min.)	°C / °F (max.)	Kg/m ² / lb/ft ²
	N/m	lb/ft	N/m	lb/ft			
Polypropylene	19800	1356	-	-	+5 / +41	+90 / +194	5,5 / 1.13
Polyethylene	9900	678	-	-	-73 / -99.4	+66 / +150.8	5,8 / 1.19
Acetal	35200	2411	-	-	-43 / -45.4	+110 / +230	8,4 / 1.71

- Belt strength and temperature values are maximum on the table.

MD254 C / Standard Belt Widths

BELT SERIES	WIDTH (W)				Belt With Tolerance (max.)
	PP-PE		POM		
	mm	inch	mm	inch	
MD254 C	200,0	7.87	200,0	7.87	± 1 mm
MD254 C	250,0	9.84	250,0	9.84	± 1 mm
MD254 C	300,0	11.81	300,0	11.81	± 2 mm
MD254 C	350,0	13.77	350,0	13.77	± 2 mm
MD254 C	400,0	15.75	400,0	15.75	± 2 mm
MD254 C	450,0	17.71	450,0	17.71	± 2 mm
MD254 C	500,0	19.69	500,0	19.69	± 2 mm
MD254 C	550,0	21.65	550,0	21.65	± 3 mm
MD254 C	600,0	23.62	600,0	23.62	± 3 mm
MD254 C	650,0	25.60	650,0	25.60	± 3 mm
MD254 C	700,0	27.56	700,0	27.56	± 3 mm
MD254 C	750,0	29.50	750,0	29.50	± 3 mm
MD254 C	800,0	31.50	800,0	31.50	± 3 mm
MD254 C	850,0	33.46	850,0	33.46	± 4 mm
MD254 C	900,0	35.43	900,0	35.43	± 4 mm

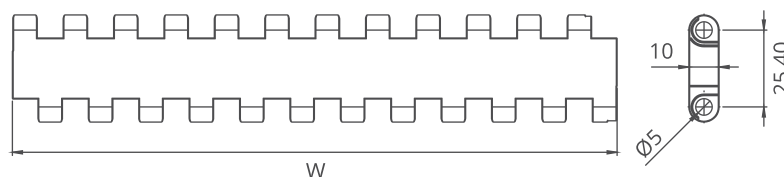

- Standard belt increments 50 mm.
- Non-standard belt increments 16,6 mm.
- Please contact with customer service for precise belt measurements.



MD254 GT

Modular Belt Series

• Snack Food Applications

Incline - Decline Lines, Container Conveyance

• Packaging Applications

Box Incline - Decline Lines

• Beverage Applications

Incline - Decline Lines, Filling, Box Transfer



MD254 GT



Pitch:	25,4 mm / 1 inch
Belt Surface:	Close, Friction Surface
Minimum Width:	50 mm / 1.97 inch
Open Area (%):	0%
Flight:	Yes (T25, T50, TC50, TCH50, TNC75, TNC100, T75, T100)
Sidewall:	Yes (h=25mm, h=50mm, h=75mm, h=100mm)
Rod:	Ø 5 mm / 0.197 inch - Self Lock
Approved:	FDA and EU
Curve:	No
Color:	Additional colors available
Cleanability:	Good
Belt Thickness:	14 mm / 0.551 inch

Product Features and Functional Benefits

- Unique rubber top eliminates wear and increases friction in incline-decline applications.
- Bi-directional belt for long conveyors.

Available Moulded Module Sizes

- 200 mm / **7.87 inch** module
- 100 mm / **3.94 inch** module
- 100 mm / **3.94 inch** edge module with 50 mm indent

MD254 GT / Technical Information

BELT MATERIAL	BELT STRENGTH				TEMPERATURE		BELT WEIGHT
	Straight		Curve		°C / °F (min.)	°C / °F (max.)	Kg/m ² / lb/ft ²
	N/m	lb/ft	N/m	lb/ft			
Polypropylene	19800	1356	-	-	+5 / +41	+90 / +194	8,7 / 1.74
Polyethylene	-	-	-	-	-	-	-
Acetal	-	-	-	-	-	-	-

- Belt strength and temperature values are maximum on the table.

MD254 GT / Standard Belt Widths

BELT SERIES	WIDTH (W)				Belt With Tolerance (max.)
	PP		POM		
	mm	inch	mm	inch	
MD254 GT	200,0	7.87	-	-	± 1 mm
MD254 GT	250,0	9.84	-	-	± 1 mm
MD254 GT	300,0	11.81	-	-	± 2 mm
MD254 GT	350,0	13.77	-	-	± 2 mm
MD254 GT	400,0	15.75	-	-	± 2 mm
MD254 GT	450,0	17.71	-	-	± 2 mm
MD254 GT	500,0	19.69	-	-	± 2 mm
MD254 GT	550,0	21.65	-	-	± 3 mm
MD254 GT	600,0	23.62	-	-	± 3 mm
MD254 GT	650,0	25.60	-	-	± 3 mm
MD254 GT	700,0	27.56	-	-	± 3 mm
MD254 GT	750,0	29.50	-	-	± 3 mm
MD254 GT	800,0	31.50	-	-	± 3 mm
MD254 GT	850,0	33.46	-	-	± 4 mm
MD254 GT	900,0	35.43	-	-	± 4 mm

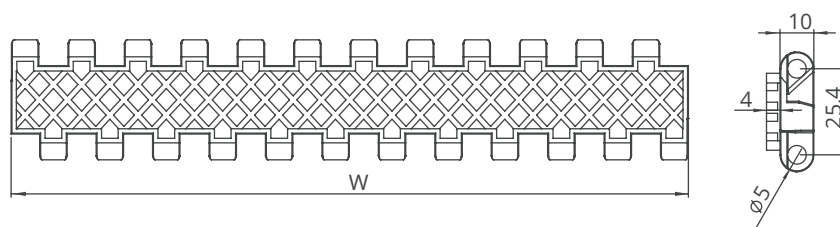

- Standard belt increments 50 mm.
- Non-standard belt increments 16,6 mm.
- Please contact with customer service for precise belt measurements.

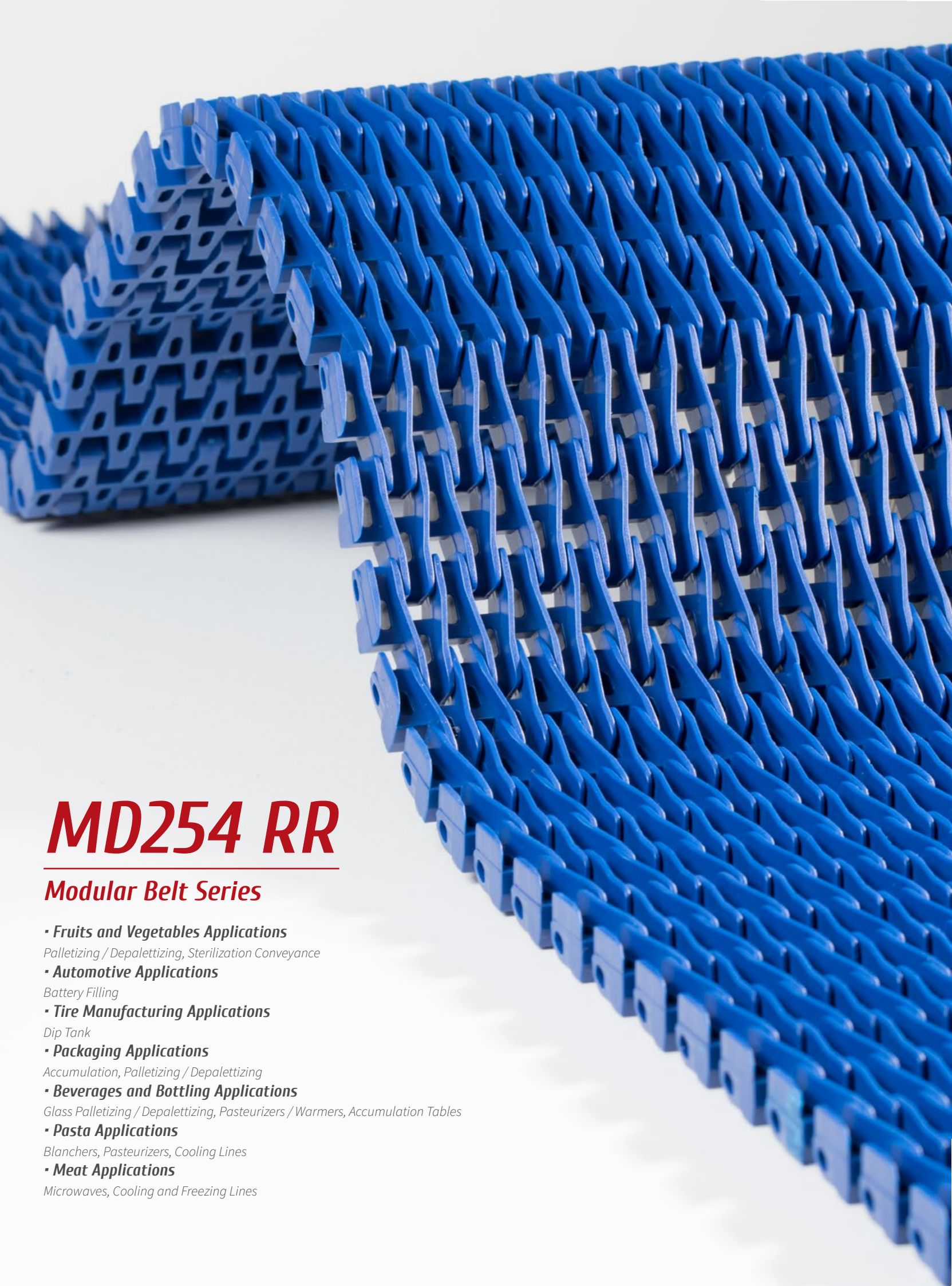

MD254 RR

Modular Belt Series

• **Fruits and Vegetables Applications**

Palletizing / Depalletizing, Sterilization Conveyance

• **Automotive Applications**

Battery Filling

• **Tire Manufacturing Applications**

Dip Tank

• **Packaging Applications**

Accumulation, Palletizing / Depalletizing

• **Beverages and Bottling Applications**

Glass Palletizing / Depalletizing, Pasteurizers / Warmers, Accumulation Tables

• **Pasta Applications**

Blanched, Pasteurizers, Cooling Lines

• **Meat Applications**

Microwaves, Cooling and Freezing Lines



MD254 RR

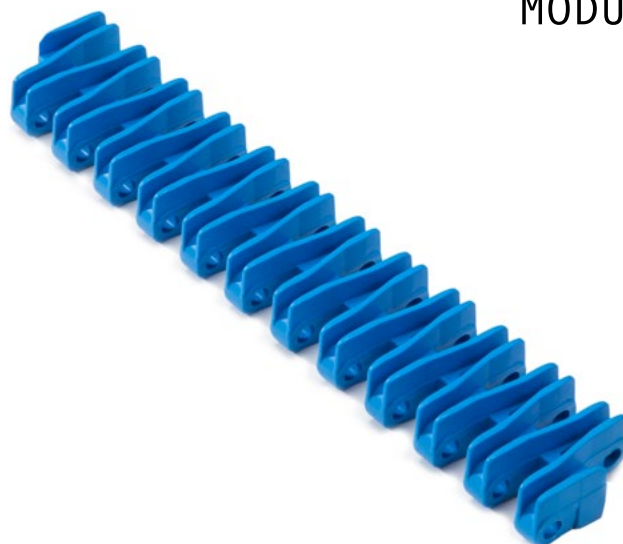

Pitch:	25,4 mm / 1 inch
Belt Surface:	Open, Raised Rib Surface
Minimum Width:	50 mm / 1.97 inch
Open Area (%):	33%. (Biggest opening 5,5 x 7 mm)
Flight:	No
Sidewall:	No
Rod:	Ø 5 mm / 0.197 inch - Self Lock
Approved:	FDA and EU
Curve:	No
Color:	Additional colors available
Cleanability:	Good
Belt Thickness:	16 mm / 0.630 inch

Product Features and Functional Benefits

- Less friction and product contact for easy cooking , cooling and freezing of products.
- Reduces back line pressure with up to 70%.
- Reduced dirt and oxide build up due to self cleaning surface.
- Finger plate for trouble free transfer.
- Bi-directional belt for long conveyors.

Available Moulded Module Sizes

- 200 mm / **7.87 inch** module
- 100 mm / **3.94 inch** module
- 50 mm / **1.97 inch** module
- 33 mm / **1.30 inch** module

MD254 RR / Technical Information

BELT MATERIAL	BELT STRENGTH				TEMPERATURE		BELT WEIGHT
	Straight		Curve		°C / °F (min.)	°C / °F (max.)	Kg/m ² / lb/ft ²
	N/m	lb/ft	N/m	lb/ft			
Polypropylene	17600	1206	-	-	+5 / +41	+90 / +194	6,8 / 1.40
PPHomopolymer	17600	1206	-	-	+5 / +41	+118 / +245	6,8 / 1.40
Acetal	29700	2035	-	-	-43 / -45.4	+110 / +230	10,4 / 2.13

- Belt strength and temperature values are maximum on the table.

MD254 RR / Standard Belt Widths

BELT SERIES	WIDTH (W)				Belt With Tolerance (max.)
	PP-PPH		POM		
	mm	inch	mm	inch	
MD254 RR	200,0	7.87	200,0	7.87	± 1 mm
MD254 RR	250,0	9.84	250,0	9.84	± 1 mm
MD254 RR	300,0	11.81	300,0	11.81	± 2 mm
MD254 RR	350,0	13.77	350,0	13.77	± 2 mm
MD254 RR	400,0	15.75	400,0	15.75	± 2 mm
MD254 RR	450,0	17.71	450,0	17.71	± 2 mm
MD254 RR	500,0	19.69	500,0	19.69	± 2 mm
MD254 RR	550,0	21.65	550,0	21.65	± 3 mm
MD254 RR	600,0	23.62	600,0	23.62	± 3 mm
MD254 RR	650,0	25.60	650,0	25.60	± 3 mm
MD254 RR	700,0	27.56	700,0	27.56	± 3 mm
MD254 RR	750,0	29.50	750,0	29.50	± 3 mm
MD254 RR	800,0	31.50	800,0	31.50	± 3 mm
MD254 RR	850,0	33.46	850,0	33.46	± 4 mm
MD254 RR	900,0	35.43	900,0	35.43	± 4 mm

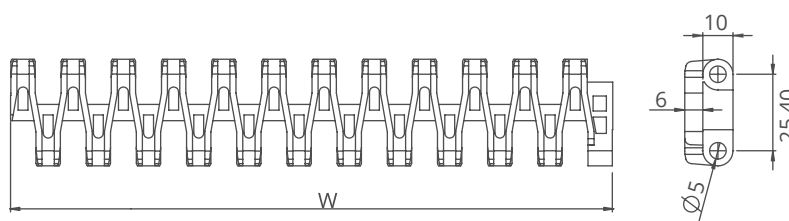

MD254 RR Comb / Finger Plate is available

This product is used for transferring of cans, bottles, etc.

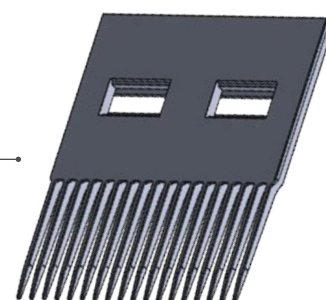

- Standard belt increments 50 mm.
- Non-standard belt increments 16,6 mm.
- Please contact with customer service for precise belt measurements.

MD254 Series Sprockets and Technical Specifications



Z15



Z8

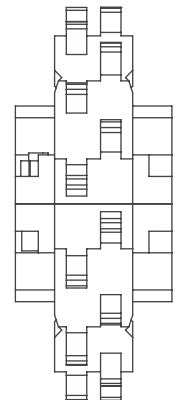
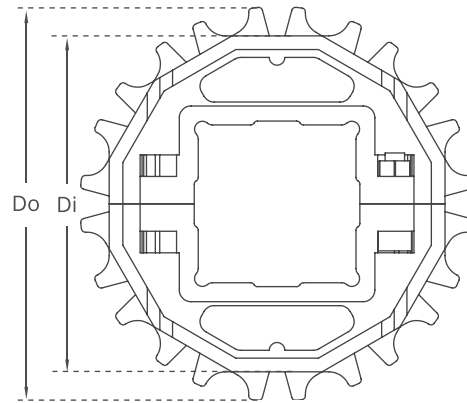
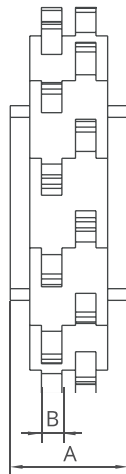
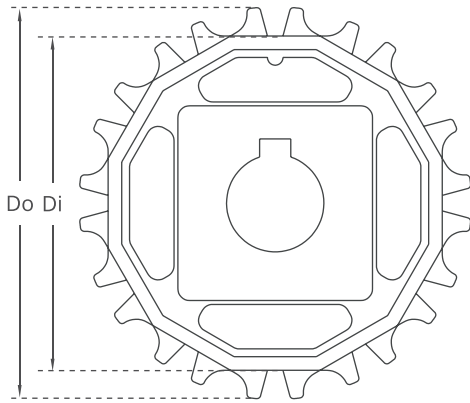

Split moulded sprockets are available.

MD254 Series / Standard Sprockets Dimensions

NO. TEETH	Di mm/inch	Do mm/inch	B mm/inch	A mm/inch	Square Bore (Q) mm/inch	Round Bore (R) mm/inch	PRODUCT CODE	
							Square Type (Q)	Round Type (R)
Z8	52,0 / 2.05	67,0 / 2.64	6 / 0.24	30 / 1.18	25 / 1	25 / 1	MD-TR254SQ25Z8*POM	MD-TR254SRZ8*POM
Z10	69,0 / 2.72	84,0 / 3.31	6 / 0.24	30 / 1.18	40 / 1.5	25-30 / 1-1.25	MD-TR254SQZ10*POM	MD-TR254SRZ10*POM
Z12	85,84 / 3.38	100,84 / 3.97	6 / 0.24	30 / 1.18	40 / 1.5	25-30 / 1-1.25	MD-TR254SQZ12*POM	MD-TR254SRZ12*POM
Z15	110,8 / 4.36	125,8 / 4.95	6 / 0.24	30 / 1.18	40 / 1.5	25-30 / 1-1.25	MD-TR254SQZ15*POM	MD-TR254SRZ15*POM
Z16	119,1 / 4.69	134,1 / 5.28	6 / 0.24	30 / 1.18	40 / 1.5	25-30 / 1-1.25	MD-TR254SQZ16*POM	MD-TR254SRZ16*POM
Z18	135,63 / 5.34	150,58 / 5.93	6 / 0.24	30 / 1.18	40 / 1.5	25-30 / 1-1.25	MD-TR254SQZ18*POM	MD-TR254SRZ18*POM

*Other sprockets and hub sizes are manufactured up to request. *PA (Polyamide) and PP (Polypropylene) sprockets raw material is available on request.

***Machined Split Sprockets are available for each size.**



Clamp



Machined Split Sprocket

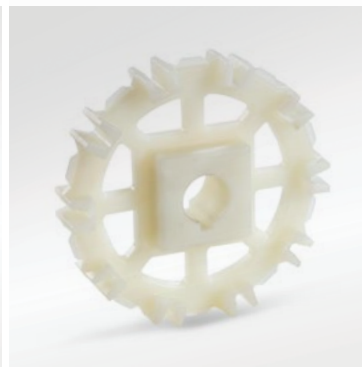

Moulded Sprocket

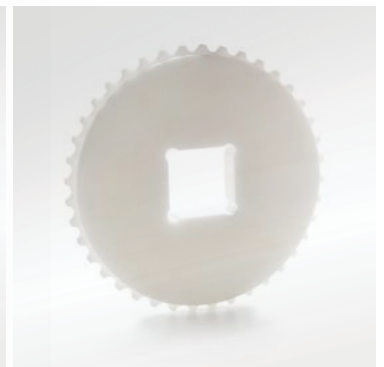

Machined Sprocket



MD254 Series Accessories and Technical Specifications

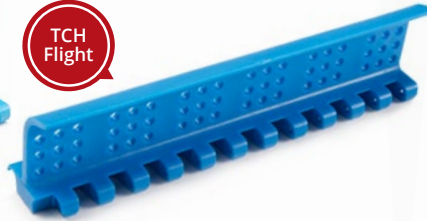

MD254 Series / Flight & Sidewall Dimensions

MD254 Series / Flights & Sidewalls				
PRODUCT CODE	Flight Height (mm/inch)	Flight Width (mm/inch)	PRODUCT CODE	Sidewall Height (mm/inch)
MD254T25	25 / 1	200 / 7.87	MD254SW25	25 / 1
MD254T50	50 / 2	200 / 7.87	MD254SW50	50 / 2
MD254T75	75 / 3	200 / 7.87	MD254SW75	75 / 3
MD254T100	100 / 4	200 / 7.87	MD254SW100	100 / 4
MD254TC50	50 / 2	200 / 7.87	-	-
MD254TCH50	50 / 2	200 / 7.87	-	-
MD254TNC75	75 / 3	200 / 7.87	-	-
MD254TNC100	100 / 4	200 / 7.87	-	-

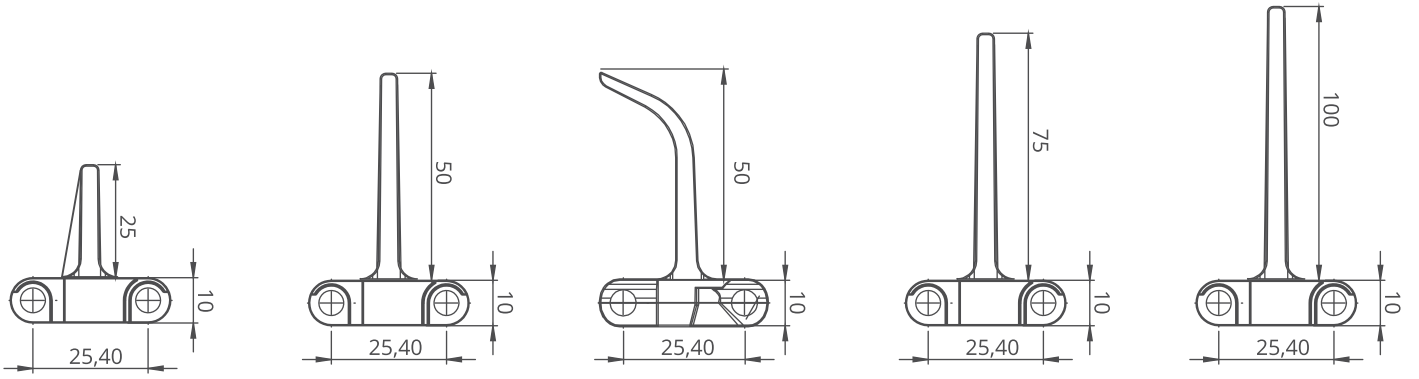

* Additional flight dimensions are available up to 100 mm.

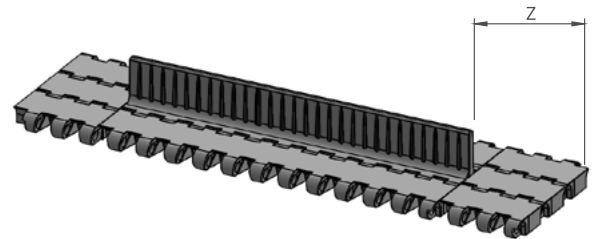
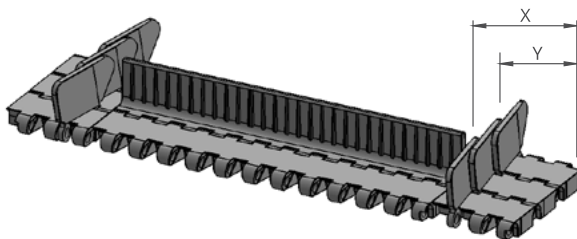

MD254 Series / Sidewall Technical Specifications

Possible Sidewall and Flight Indents	X		Y	
	mm	inch	mm	inch
Standard, no module cutting	24,0	0.94	15,0	0.59
Module cutting necessary for belt and flight	32,0	1.26	22,0	0.87
Standard, no module cutting	40,0	1.57	30,0	1.18
Module cutting necessary for belt and flight	48,0	1.89	37,0	1.46
Module cutting necessary for belt	56,0	2.20	45,0	1.77
Module cutting necessary for belt and flight	64,0	2.52	53,0	2.09
Standard, no module cutting	73,0	2.87	60,0	2.36
Module cutting necessary for belt and flight	81,0	3.19	68,0	2.68
Standard, no module cutting	90,0	3.54	75,0	2.95

MD254 Series / Flight Technical Specifications

Possible Flight Indents for MD254 Series	Z	
	mm	inch
Standard, no module cutting	33,5	1.32
Standard, no module cutting	50,0	1.97
Standard, module cutting	83,5	3.29
Standard, no module cutting	100,0	3.94

*Non-standard flight indent is on request.

Note: Gap between flight and sidewall minimum 2-3 mm

MD254 Series *Engineering Information*

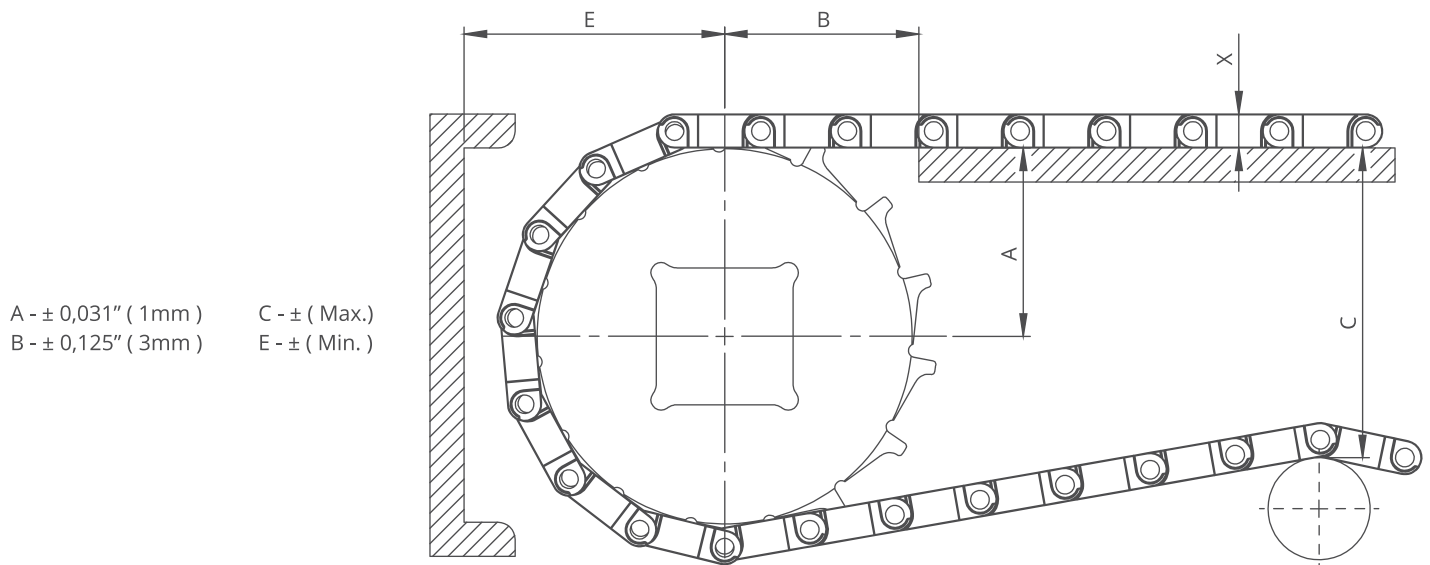

A - ± 0,031" (1mm) C - ± (Max.)
 B - ± 0,125" (3mm) E - ± (Min.)

MD254 Series / Conveyor Frame Dimensions

Sprockets Description			A		B		C		E		X	
Pitch Diameter		No.Teeth	Range (Bottom to Top)		inch	mm	inch	mm	inch	mm	inch	mm
inch	mm		inch	mm								
MD254 FG, MD254 C												
2.38	60,5	8	1.15	29,2	1.55	39,4	1.95	49,5	1.94	49,2	0.39	10,0
3.07	78,0	10	1.46	37,1	1.77	45,0	2.60	66,1	2.25	57,1	0.39	10,0
3.74	95,0	12	1.76	44,8	1.97	50,1	3.24	82,3	2.55	64,8	0.39	10,0
4.70	119,5	15	2.22	56,4	2.23	56,7	4.18	106,1	3.01	76,4	0.39	10,0
5.02	127,5	16	2.37	60,2	2.38	60,5	4.46	113,2	3.21	81,5	0.39	10,0
5.71	145,0	18	2.73	69,3	2.45	62,3	5.19	131,8	3.51	89,3	0.39	10,0
MD254 RR, MD254 GT												
2.38	60,5	8	1.15	29,2	1.55	39,4	1.95	49,5	2.18	55,4	0.64	16,3
3.07	78,0	10	1.46	37,1	1.77	45,0	2.60	66,1	2.48	63,1	0.64	16,3
3.74	95,0	12	1.76	44,8	1.97	50,1	3.24	82,3	2.79	70,9	0.64	16,3
4.70	119,5	15	2.22	56,4	2.23	56,7	4.18	106,1	3.25	82,7	0.64	16,3
5.02	127,5	16	2.37	60,2	2.38	60,5	4.46	113,2	3.46	87,8	0.64	16,3
5.71	145,0	18	2.73	69,3	2.45	62,3	5.19	131,8	3.76	95,5	0.64	16,3

MD254 Series / Slider Support System For Straight Running Belts

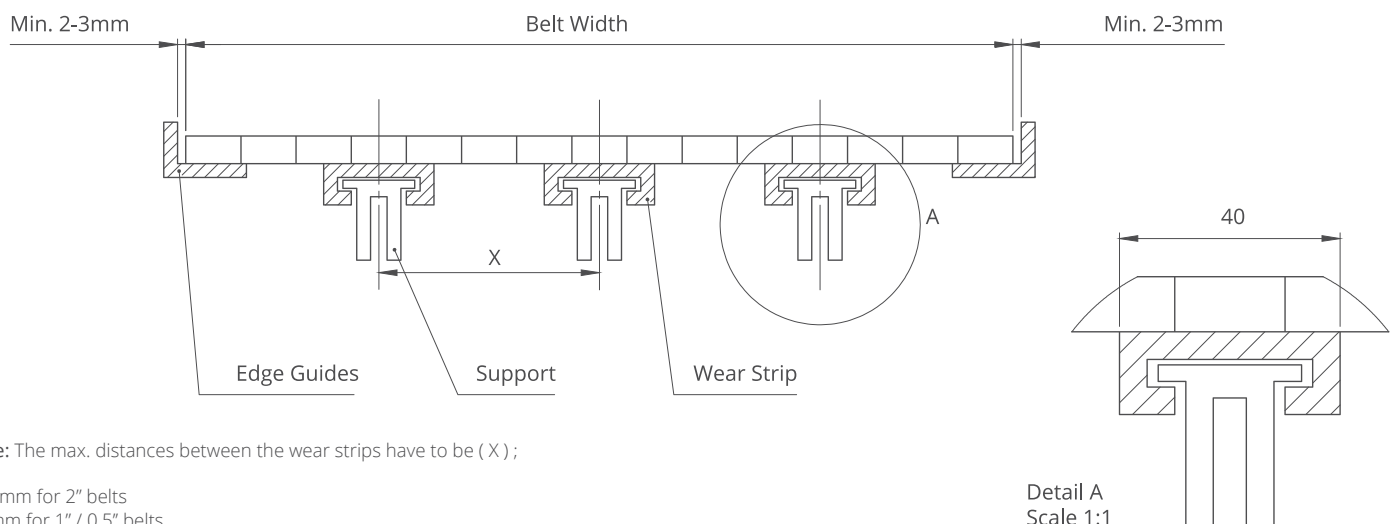

Note: The max. distances between the wear strips have to be (X) ;

125 mm for 2" belts
 80 mm for 1" / 0.5" belts

Detail A
 Scale 1:1

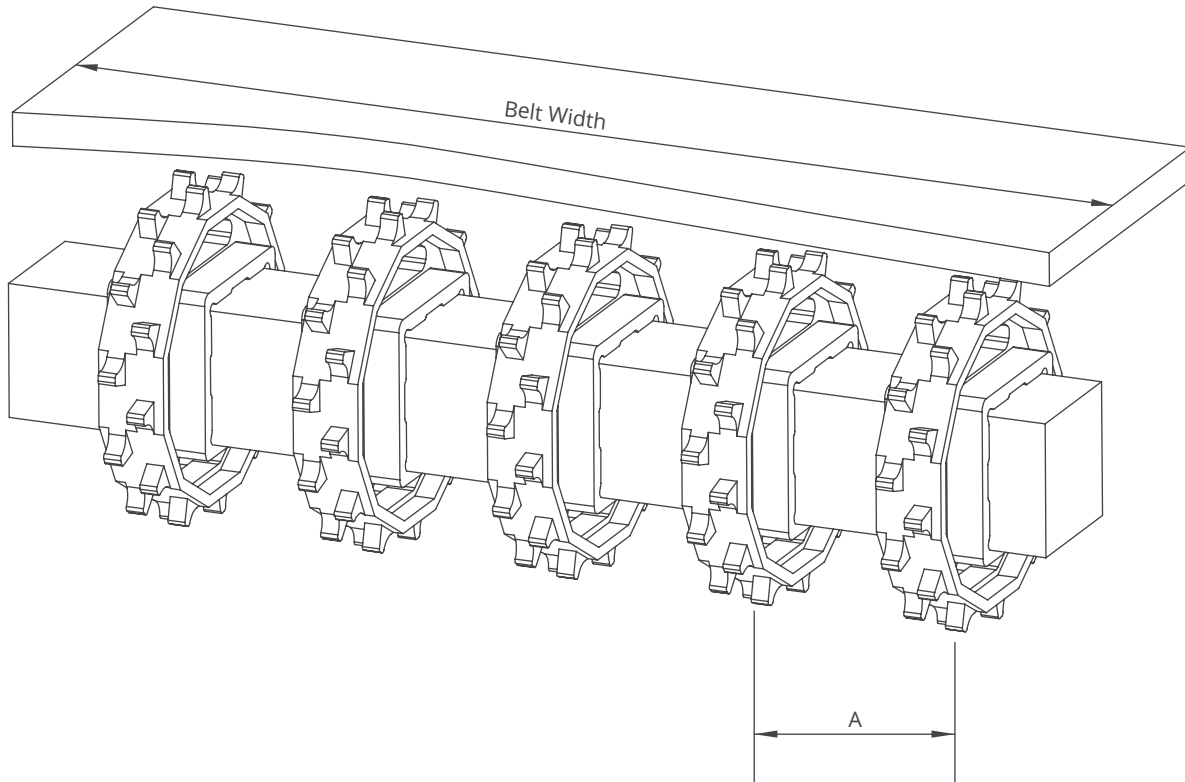

MD254 Series / Sprockets Arrangement

Standard Belt Width		Number of sprockets per shaft		A (mm/inch)	
mm	inch	Drive Shaft	Return Shaft	Min.	Max.
150,0	6.0	2	2	50/2	120/4.7
200,0	8.0	2	2	50/2	120/4.7
250,0	10.0	3	2	50/2	120/4.7
300,0	12.0	3	2	50/2	120/4.7
350,0	14.0	3	3	50/2	120/4.7
400,0	16.0	4	3	50/2	120/4.7
450,0	18.0	4	3	50/2	120/4.7
500,0	20.0	5	4	50/2	120/4.7
550,0	22.0	5	4	50/2	120/4.7
600,0	24.0	6	5	50/2	120/4.7
700,0	26.0	7	5	50/2	120/4.7
800,0	28.0	8	6	50/2	120/4.7
900,0	30.0	9	7	50/2	120/4.7
1000,0	32.0	10	7	50/2	120/4.7

Note: Number of sprockets depends on the belt load.



MODUTECH®

MD254 GAP%48

Modular Belt Serie

MD254 GAP%48

Sprockets & Accessories

Engineering Information







MD254 GAP%48

Modular Belt Serie

- **Bakery Applications**

Including Oven Infeed - Outfeed, Coating Lines, Glazing Lines, Freezing Lines, Conditioning Lines, Cooling Lines

- **Poultry Applications**

Cooling and Freezing Lines

- **Seafood Applications**

Including Breeding Machines, Draining Lines

- **Snack Food Applications**

Including Proofer Lines, Boiler Infeed, Oven Infeed - Outfeed, Cooling Lines

- **Fruits and Vegetables Applications**

Including Prewashing / Rinsing, Draining

- **Packing Industry**

Shrink Tunnels



MD254 GAP%48

Pitch:	25,7 mm / 1 inch
Belt Surface:	Open, Smooth Surface
Minimum Width:	203,2 mm / 8 inch
Open Area (%):	48%. (Biggest opening 9 x 13,5 mm and 6 x 16,5 mm)
Flight:	Yes (T50)
Sidewall:	No
Rod:	Ø5 mm / 0.197 inch - Self Lock
Approved:	FDA and EU
Curve:	No
Color:	Additional colors available
Cleanability:	Excellent
Belt Thickness:	11 mm / 0.433 inch

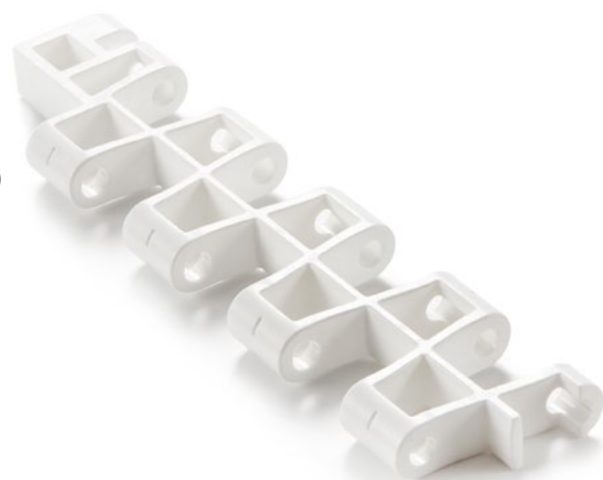

Product Features and Functional Benefits

- Belt provides optimal open area for drainage and airflow.
- Less friction and product contact for easy cooking, cooling and freezing of products.
- Reduced dirt and oxide build due to self cleaning surface.
- Stainless steel pins option for high temperature applications.
- Easy to clean reduces downtime for cleaning time 70%.
- Stainless steel pins option reduce belt elongation for high temperature application.

Available Moulded Module Sizes

- 152,4 mm / **6 inch** module
- 85 mm / **3.35 inch** module

MD254 GAP%48 / Technical Information

BELT MATERIAL	BELT STRENGTH				TEMPERATURE		BELT WEIGHT
	Straight		Curve		°C / °F (min.)	°C / °F (max.)	Kg/m ² / lb/ft ²
	N/m	lb/ft	N/m	lb/ft			
Polypropylene	12100	829	-	-	+5 / +41	+90 / +194	4,2 / 0.85
Polyethylene	-	-	-	-	-	-	-
Acetal	17050	1168	-	-	-43 / -45.4	+110 / +230	6,4 / 1.33

- Belt strength and temperature values are maximum on the table.

MD254 GAP%48 / Standard Belt Widths

BELT SERIES	WIDTH (W)				Belt With Tolerance (max.)
	PP		POM		
	mm	inch	mm	inch	
MD254GAP48	203,2	8.0	203,2	8.0	± 0,5 mm
MD254GAP48	237,0	9.0	237,0	9.0	± 1 mm
MD254GAP48	270,8	11.0	270,8	11.0	± 1 mm
MD254GAP48	304,6	12.0	304,6	12.0	± 1 mm
MD254GAP48	338,4	13.0	338,4	13.0	± 2 mm
MD254GAP48	372,2	15.0	372,2	15.0	± 2 mm
MD254GAP48	406,0	16.0	406,0	16.0	± 2 mm
MD254GAP48	439,8	17.0	439,8	17.0	± 2 mm
MD254GAP48	473,6	19.0	473,6	19.0	± 2 mm
MD254GAP48	507,4	20.0	507,4	20.0	± 2 mm
MD254GAP48	541,2	21.0	541,2	21.0	± 2 mm
MD254GAP48	575,0	23.0	575,0	23.0	± 2 mm
MD254GAP48	608,8	24.0	608,8	24.0	± 3 mm
MD254GAP48	642,6	25.0	642,6	25.0	± 3 mm

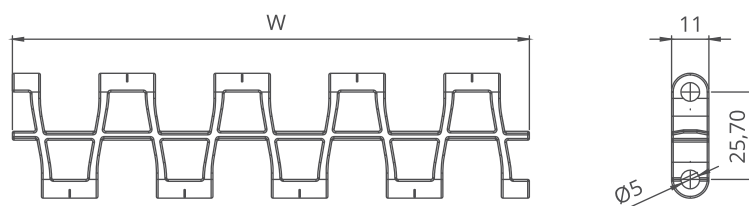

- Bigger sizes are available with 33,8 mm increments.
 - Please contact with customer service for precise belt measurements.

MD254 GAP%48 Serie *Sprockets and Technical Specifications*



Z15



Z8

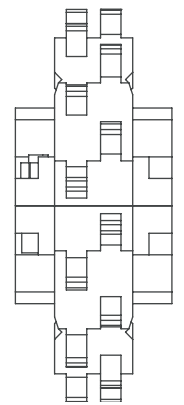
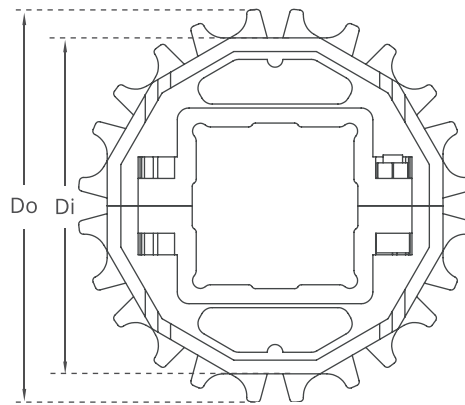
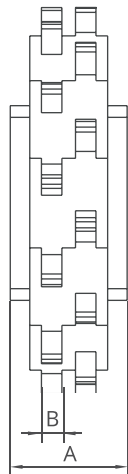
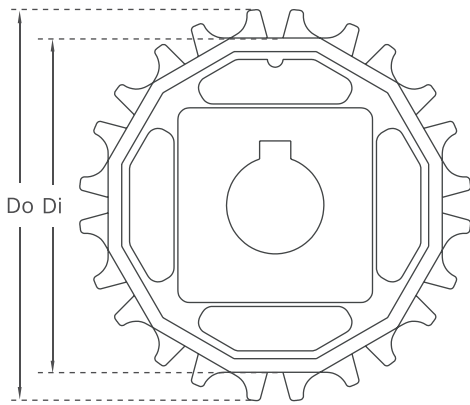

Split moulded sprockets are available.

MD254 GAP%48 Serie / Standard Sprockets Dimensions

NO. TEETH	Di mm/inch	Do mm/inch	B mm/inch	A mm/inch	Square Bore (Q) mm/inch	Round Bore (R) mm/inch	PRODUCT CODE	
							Square Type (Q)	Round Type (R)
Z8	52,0 / 2.05	67,0 / 2.64	6 / 0.24	30 / 1.18	25 / 1	25 / 1	MD-TR254SQ25Z8*POM	MD-TR254SRZ8*POM
Z10	69,0 / 2.72	84,0 / 3.31	6 / 0.24	30 / 1.18	40 / 1.5	25-30 / 1-1.25	MD-TR254SQZ10*POM	MD-TR254SRZ10*POM
Z12	85,84 / 3.38	100,84 / 3.97	6 / 0.24	30 / 1.18	40 / 1.5	25-30 / 1-1.25	MD-TR254SQZ12*POM	MD-TR254SRZ12*POM
Z15	110,8 / 4.36	125,8 / 4.95	6 / 0.24	30 / 1.18	40 / 1.5	25-30 / 1-1.25	MD-TR254SQZ15*POM	MD-TR254SRZ15*POM
Z16	119,1 / 4.69	134,1 / 5.28	6 / 0.24	30 / 1.18	40 / 1.5	25-30 / 1-1.25	MD-TR254SQZ16*POM	MD-TR254SRZ16*POM
Z18	135,63 / 5.34	150,58 / 5.93	6 / 0.24	30 / 1.18	40 / 1.5	25-30 / 1-1.25	MD-TR254SQZ18*POM	MD-TR254SRZ18*POM

*Other sprockets and hub sizes are manufactured up to request. *PA (Polyamide) and PP (Polypropylene) sprockets raw material is available on request.

***Machined sprockets are available for each size.**

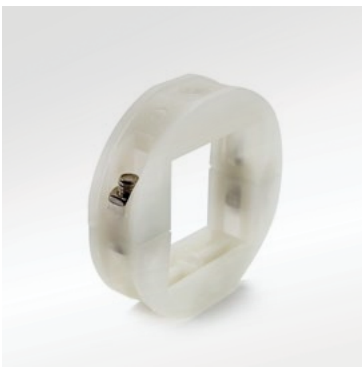

Clamp



Machined Split Sprocket

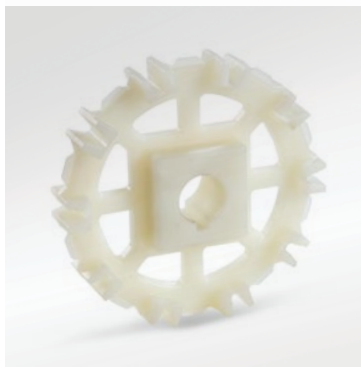

Moulded Sprocket

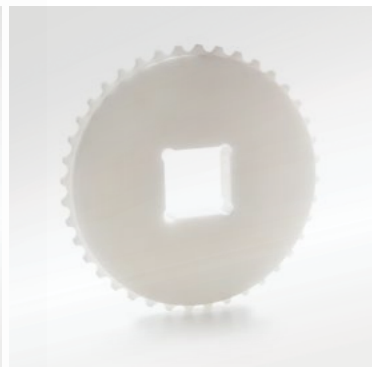

Machined Sprocket

MD254 GAP%48 Serie *Engineering Information*

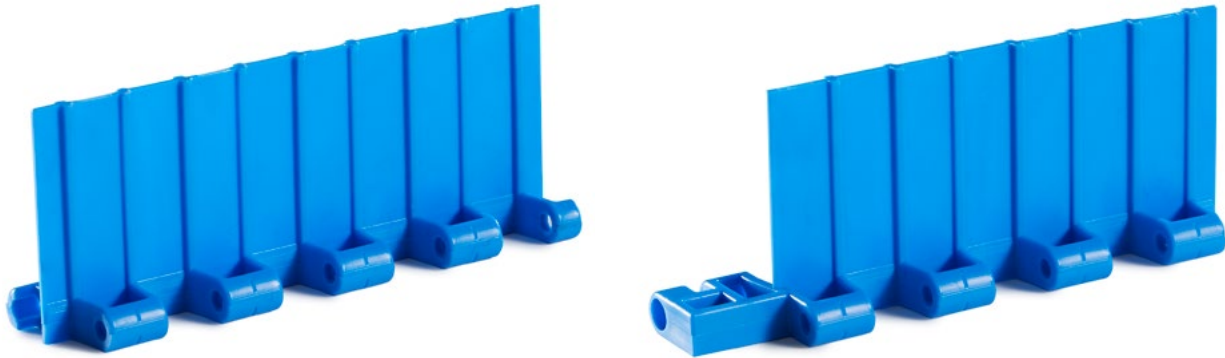

MD254 GAP%48 Serie / Flight Dimensions

MD254 GAP%48 Serie / Flights				
PRODUCT CODE	Flight Height (mm/ <i>inch</i>)	Flight Width (mm/ <i>inch</i>)	PRODUCT CODE	Sidewall Height (mm/ <i>inch</i>)
MD254G48T50	50 / 2	152 / 6	-	-

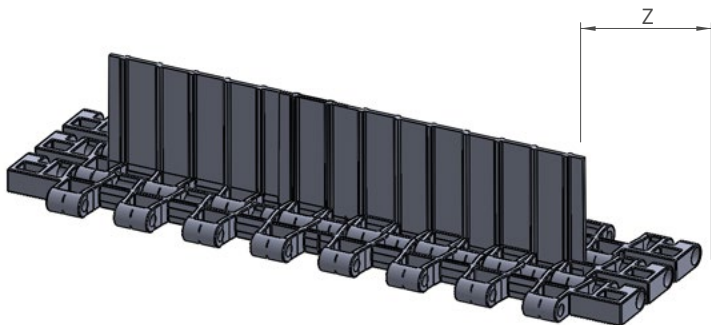
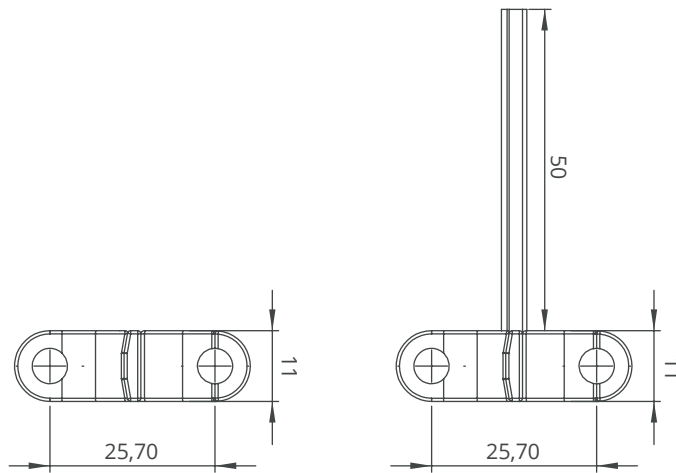

MD254 GAP%48 Serie / Flight Technical Specifications

Possible Flight Indents for MD254GAP%48 Serie	Z	
	mm	<i>inch</i>
Standard, no module cutting	35,0	1.38
Standard, module cutting	68,8	2.71
Standard, module cutting	102,6	4.04

*Non-standard flight indent is on request.

MD254 GAP%48 Serie *Engineering Information*

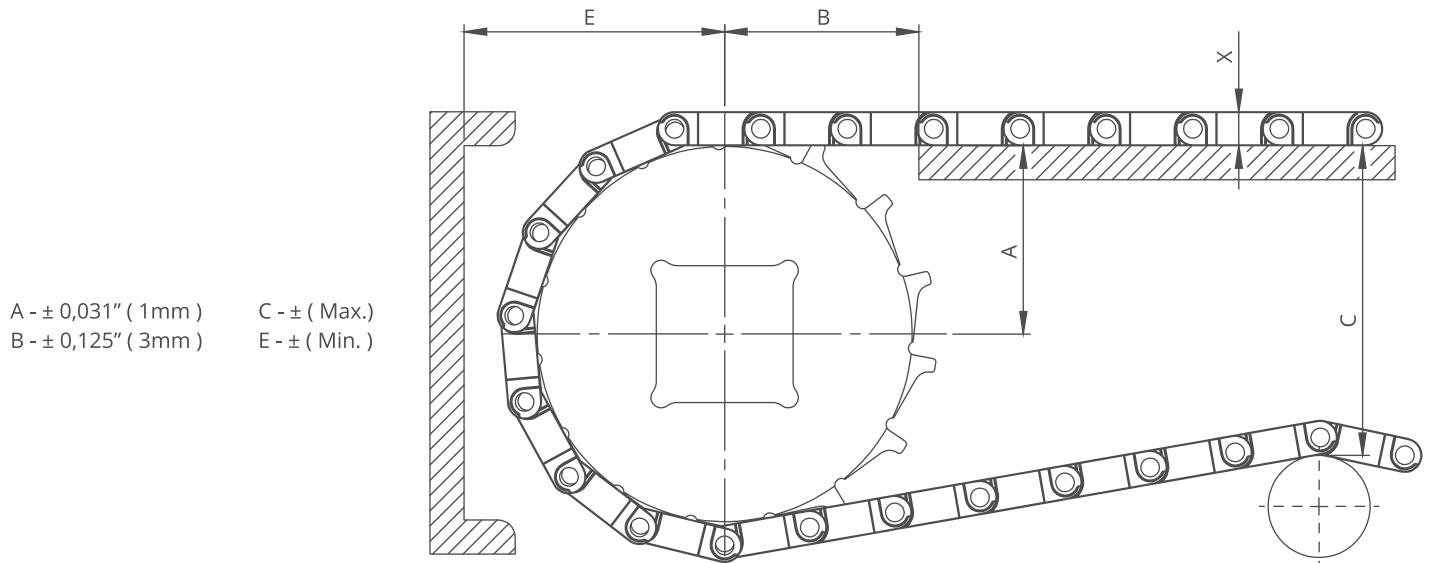

A - $\pm 0,031''$ (1mm) C - \pm (Max.)
 B - $\pm 0,125''$ (3mm) E - \pm (Min.)

MD254 GAP%48 Serie / Conveyor Frame Dimensions

Sprockets Description			A		B		C		E		X	
Pitch Diameter		No.Teeth	Range (Bottom to Top)		inch	mm	inch	mm	inch	mm	inch	mm
inch	mm		inch	mm								
MD254 GAP%48												
2.38	60,5	8	1.15	29,2	1.55	39,4	1.95	49,5	1.94	49,2	0.43	11,0
3.07	78,0	10	1.46	37,1	1.77	45,0	2.60	66,1	2.25	57,1	0.43	11,0
3.74	95,0	12	1.76	44,8	1.97	50,1	3.24	82,3	2.55	64,8	0.43	11,0
4.70	119,5	15	2.22	56,4	2.23	56,7	4.18	106,1	3.01	76,4	0.43	11,0
5.02	127,5	16	2.37	60,2	2.38	60,5	4.46	113,2	3.21	81,5	0.43	11,0
5.71	145,0	18	2.73	69,3	2.45	62,3	5.19	131,8	3.51	89,3	0.43	11,0

MD254 GAP%48 Series / Slider Support System For Straight Running Belts

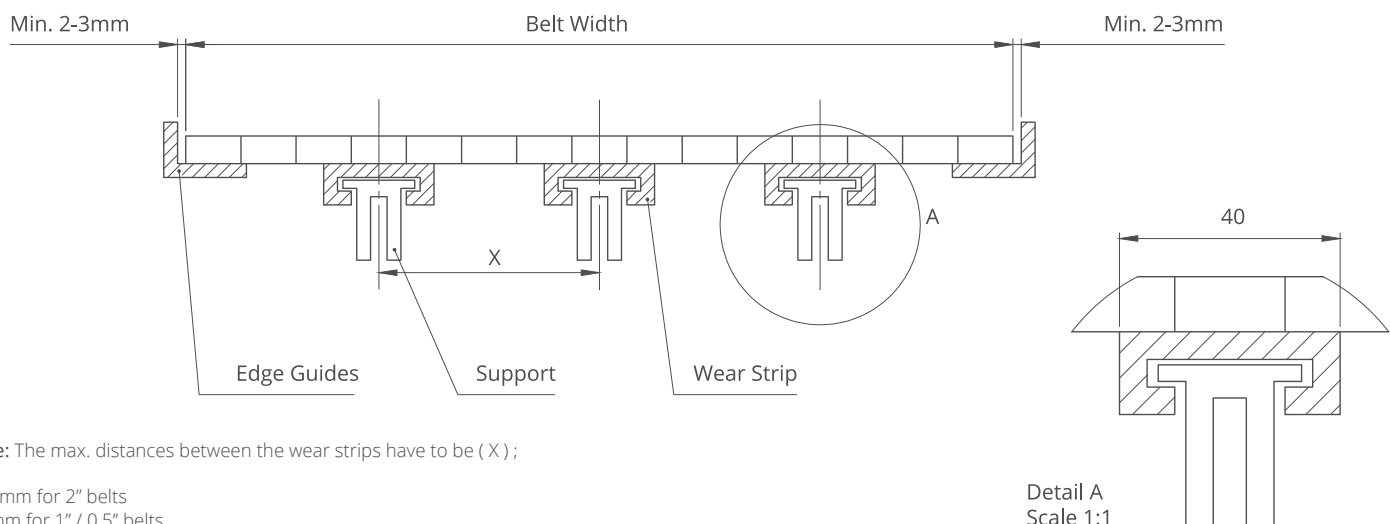

Note: The max. distances between the wear strips have to be (X) ;

125 mm for 2" belts
 80 mm for 1" / 0.5" belts

Detail A
 Scale 1:1

MD254 GAP%48 Serie *Engineering Information*



MODUTECH

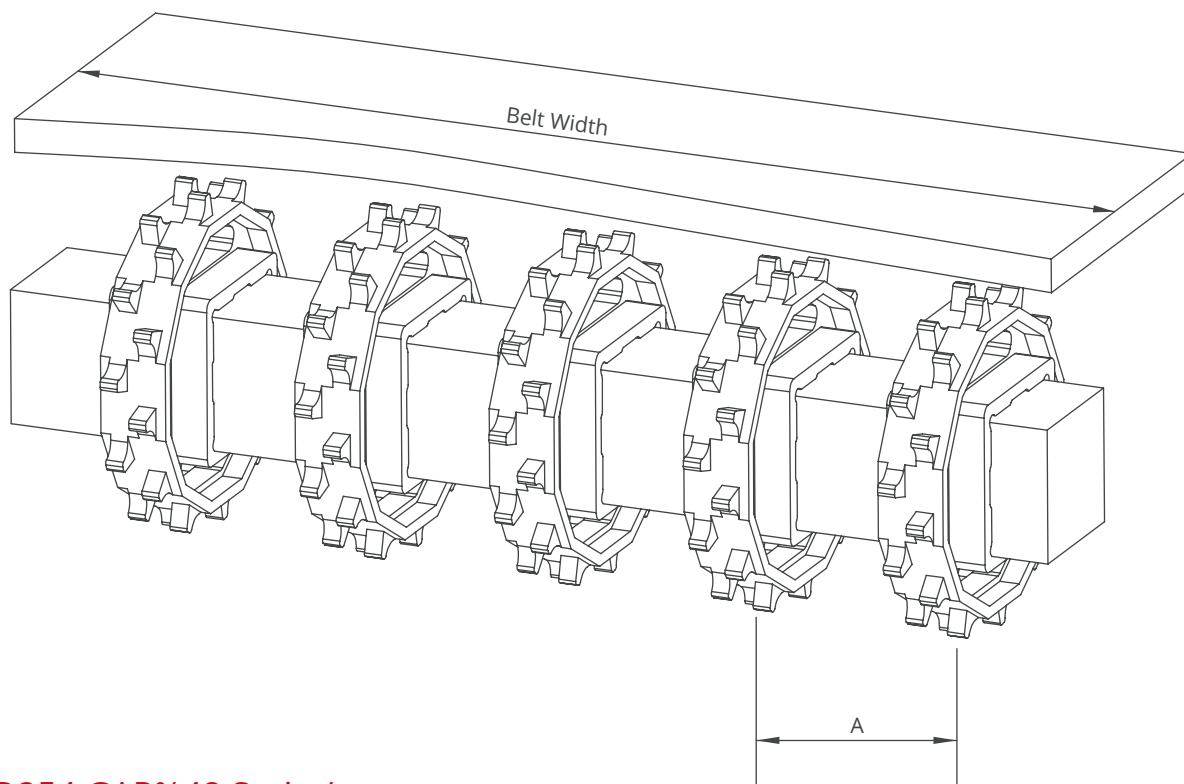

MD254 GAP%48 Serie / Sprockets Arrangement

Standard Belt Width		Number of sprockets per shaft		A (mm/inch)	
mm	inch	Drive Shaft	Return Shaft	Min.	Max.
203,2	8.0	2	2	60/2.36	170/6.6
237,0	9.3	2	2	60/2.36	170/6.6
270,8	10.7	2	2	60/2.36	170/6.6
304,6	12.0	3	2	60/2.36	170/6.6
338,4	13.3	3	2	60/2.36	170/6.6
372,2	14.7	4	3	60/2.36	170/6.6
406,0	16.0	4	3	60/2.36	170/6.6
439,8	17.3	4	3	60/2.36	170/6.6
473,6	18.6	5	3	60/2.36	170/6.6
507,4	20.0	5	3	60/2.36	170/6.6
541,2	21.3	5	3	60/2.36	170/6.6
575,0	22.6	5	3	60/2.36	170/6.6
608,8	24.0	6	4	60/2.36	170/6.6
642,6	25.3	6	4	60/2.36	170/6.6
676,4	26.6	6	4	60/2.36	170/6.6
710,2	28.0	7	4	60/2.36	170/6.6
744,0	29.3	7	4	60/2.36	170/6.6
777,8	30.6	7	4	60/2.36	170/6.6
811,6	32.0	7	4	60/2.36	170/6.6
845,4	33.3	8	4	60/2.36	170/6.6
879,2	34.6	8	5	60/2.36	170/6.6
913,0	35.9	8	5	60/2.36	170/6.6
946,8	37.3	8	5	60/2.36	170/6.6
980,6	38.6	8	5	60/2.36	170/6.6
1014,4	39.9	9	5	60/2.36	170/6.6
1048,2	41.3	9	5	60/2.36	170/6.6

Note: Number of sprockets depends on the belt load.

EC508

Modular Belt Series

EC508 C

EC508 PR%22

EC508 FG

EC508 FG-NT

EC508 PR%11

EC508 PR%13

EC508 DT

EC508 NT

Sprockets & Accessories

Engineering Information







EC508 C

Modular Belt Series

• Meat Applications

*Slaughtering - Evisceration, Cutting Lines, Debonning Lines,
Bone Takeaway, Dressing Lines, Trim Lines*

• Poultry Applications

*Live Birds, Slaughtering - Evisceration, Skinning, Cut - Up,
Chiller Discharge, Bird Accumulation, Freezing Lines, Elevator*

• Sea Food Applications

Trim Lines, Control Tables, Glazing, Elevator

• Bakery Applications

Row Dough Handling, Laminating Lines

• Snack Food Applications

Potato Processing

• Fruits and Vegetables Applications

Bulk Feeding, Elevator, Control Sorting Table, Filling

• Automotive Applications

Chair Lift - Feeder

• Packaging Applications

Bluk Inclines, Box Transport Horizontal



EC508 C

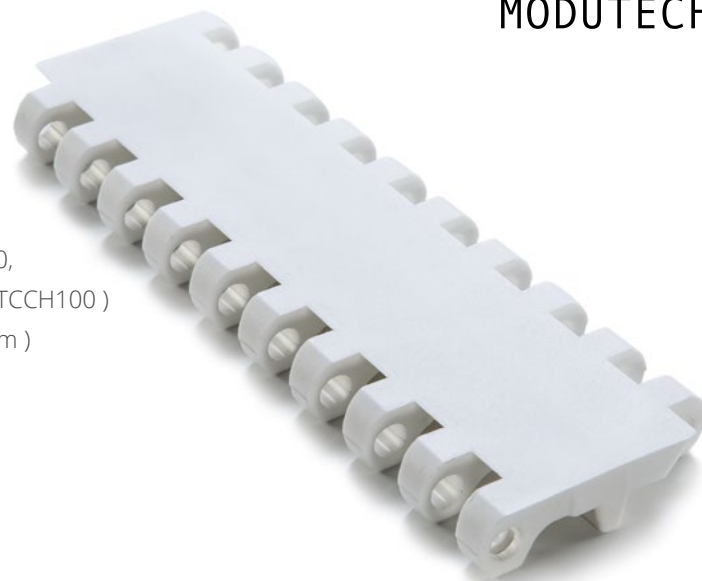

Pitch:	50,8 mm / 2 inch
Belt Surface:	Close, Smooth Surface
Minimum Width:	100 mm / 3.94 inch
Open Area (%):	0%
Flight:	Yes (T25, T50, T75, T100, T150, TNC50, TNC100, TC75, TC100, TC150, TCC75, TCC100, TCC150, TCCH100)
Sidewall:	Yes (h=25 mm, h=50 mm, h=75 mm, h=100 mm)
Rod:	Ø7 mm / 0.276 inch - Self Lock
Approved:	FDA and EU
Curve:	No
Color:	Additional colors available
Cleanability:	Excellent
Belt Thickness:	16 mm / 0.630 inch

Product Features and Functional Benefits

- Easy to clean reduces downtime for cleaning time 70%.
- Close transfer applications.
- Reduces bacteria growth.
- Unique sprocket engagement - higher product load and longer conveyors.
- Strong and thick product supports allow more load without breaking.
- Impact resistance to withstand heavy objects falling into the belt.

Available Moulded Module Sizes

- 200 mm / **7.87 inch** module
- 100 mm / **3.94 inch** module
- 60 mm / **2.36 inch** module
- 40 mm / **1.57 inch** module

EC508 C / Technical Information

BELT MATERIAL	BELT STRENGTH				TEMPERATURE		BELT WEIGHT
	Straight		Curve		°C / °F (min.)	°C / °F (max.)	Kg/m ² / lb/ft ²
	N/m	lb/ft	N/m	lb/ft			
Polypropylene	19800	1356	-	-	+5 / +41	+90 / +194	9,0 / 1.85
Polyethylene	11000	753	-	-	-73 / -99.4	+66 / +150.8	9,4 / 1.93
Acetal	33000	2260	-	-	-43 / -45.4	+110 / +230	13,5 / 2.77

- Belt strength and temperature values are maximum on the table.

EC508 C / Standard Belt Widths

BELT SERIES	WIDTH (W)				Belt With Tolerance (max.)
	PP-PE		POM		
	mm	inch	mm	inch	
EC 508 C	200,0	7.87	200,0	7.87	± 1 mm
EC 508 C	300,0	11.81	300,0	11.81	± 2 mm
EC 508 C	400,0	15.75	400,0	15.75	± 2 mm
EC 508 C	500,0	19.69	500,0	19.69	± 2 mm
EC 508 C	600,0	23.62	600,0	23.62	± 3 mm
EC 508 C	700,0	27.56	700,0	27.56	± 3 mm
EC 508 C	800,0	31.50	800,0	31.50	± 3 mm
EC 508 C	900,0	35.43	900,0	35.43	± 4 mm
EC 508 C	1000,0	39.37	1000,0	39.37	± 4 mm
EC 508 C	1100,0	43.31	1100,0	43.31	± 4 mm
EC 508 C	1200,0	47.24	1200,0	47.24	± 4 mm
EC 508 C	1300,0	51.18	1300,0	51.18	± 5 mm
EC 508 C	1400,0	55.11	1400,0	55.11	± 5 mm
EC 508 C	1500,0	59.06	1500,0	59.06	± 5 mm

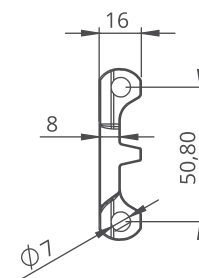
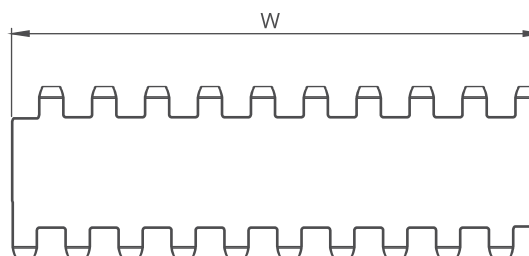

- Standard belt increments 100 mm.
- Non-standard belt increments 20 mm.
- Please contact with customer service for precise belt measurements.



EC508 PR%22

Modular Belt Series

• Meat Applications

Dressing Lines, Trim Lines, Elevator, Metal Detector

• Poultry Applications

Cut-up Lines, Debonning Lines, Chiller Discharge, Rehang / Bird Accumulation, Freezing Lines, Elevators

• Sea Food Applications

Draining, Elevator

• Snack Food Applications

Can Draining

• Fruits and Vegetables Applications

Prewashing / Rinsing, Draining, Peeling, Elevator, Blanching



EC508 PR%22

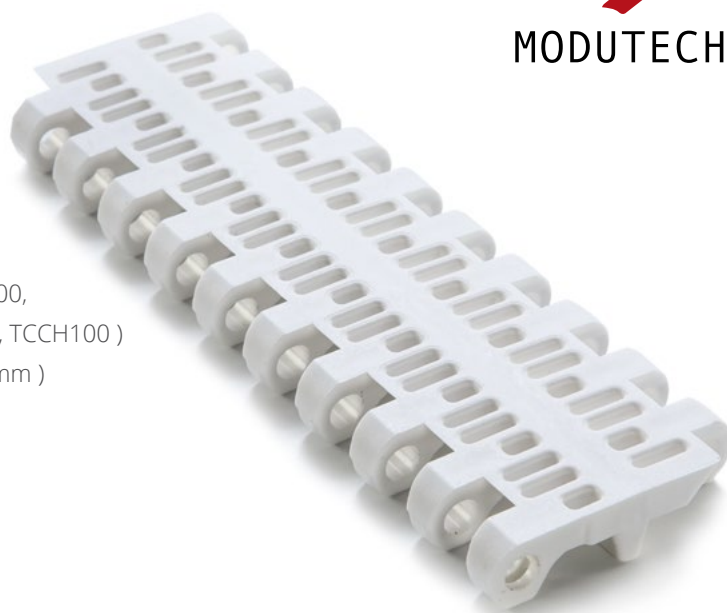

Pitch:	50,8 mm / 2 inch
Belt Surface:	Open, Smooth Surface
Minimum Width:	100 mm / 3.94 inch
Open Area (%):	22%. (Biggest opening 3 x 12 mm)
Flight:	Yes (T25, T50, T75, T100, T150, TNC50, TNC100, TC75, TC100, TC150, TCC75, TCC100, TCC150, TCCH100)
Sidewall:	Yes (h=25 mm, h=50 mm, h=75 mm, h=100 mm)
Rod:	Ø7 mm / 0.276 inch - Self Lock
Approved:	FDA and EU
Curve:	No
Color:	Additional colors available
Cleanability:	Excellent
Belt Thickness:	16 mm / 0.630 inch

Product Features and Functional Benefits

- Unique sprocket engagement - precise indexing, easy cleaning.
- Different openings to optimize performance in cooling and draining applications.
- Easy to clean reduces downtime for cleaning time 70%.
- Unique sprocket engagement - higher product load and longer conveyors.
- Reduces bacteria growth.

Available Moulded Module Sizes

- 200 mm / **7.87 inch** module
- 100 mm / **3.94 inch** module
- 60 mm / **2.36 inch** module
- 40 mm / **1.57 inch** module

EC508 PR%22 / Technical Information

BELT MATERIAL	BELT STRENGTH				TEMPERATURE		BELT WEIGHT
	Straight		Curve		°C / °F (min.)	°C / °F (max.)	Kg/m ² / lb/ft ²
	N/m	lb/ft	N/m	lb/ft			
Polypropylene	19800	1356	-	-	+5 / +41	+90 / +194	6,7 / 1.37
Polyethylene	11000	753	-	-	-73 / -99.4	+66 / +150.8	7,0 / 1.43
Acetal	33000	2260	-	-	-43 / -45.4	+110 / +230	8,7 / 1.78

- Belt strength and temperature values are maximum on the table.

EC508 PR%22 / Standard Belt Widths

BELT SERIES	WIDTH (W)				Belt With Tolerance (max.)
	PP-PE		POM		
	mm	inch	mm	inch	
EC508 PR22	200,0	7.87	200,0	7.87	± 1 mm
EC508 PR22	300,0	11.81	300,0	11.81	± 2 mm
EC508 PR22	400,0	15.75	400,0	15.75	± 2 mm
EC508 PR22	500,0	19.69	500,0	19.69	± 2 mm
EC508 PR22	600,0	23.62	600,0	23.62	± 3 mm
EC508 PR22	700,0	27.56	700,0	27.56	± 3 mm
EC508 PR22	800,0	31.50	800,0	31.50	± 3 mm
EC508 PR22	900,0	35.43	900,0	35.43	± 4 mm
EC508 PR22	1000,0	39.37	1000,0	39.37	± 4 mm
EC508 PR22	1100,0	43.31	1100,0	43.31	± 4 mm
EC508 PR22	1200,0	47.24	1200,0	47.24	± 4 mm
EC508 PR22	1300,0	51.18	1300,0	51.18	± 5 mm
EC508 PR22	1400,0	55.11	1400,0	55.11	± 5 mm
EC508 PR22	1500,0	59.06	1500,0	59.06	± 5 mm

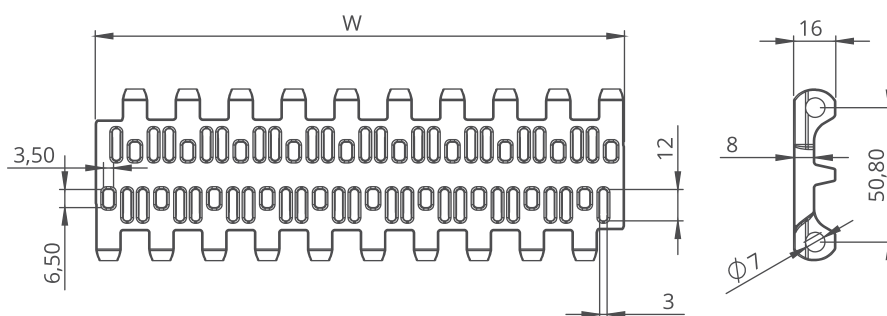

- Standard belt increments 100 mm.
- Non-standard belt increments 20 mm.
- Please contact with customer service for precise belt measurements.



EC508 FG

Modular Belt Series

• Bakery Applications

*Oven Infeed/Outfeed, Cooling Lines, Coating Lines, Glazing Lines,
Freezing Lines, Conditioning Lines*

• Sea Food Applications

Breeding Machines, Draining Lines

• Snack Food Applications

Proofer Lines, Boiler Infeed, Oven Infeed / Outfeed, Cooling Lines

• Fruits and Vegetables Applications

Prewashing / Rinsing, Draining

• Tire Manufacturing Applications

*Mixer Infeed / Outfeed, Extrusion Shower Lines, Cooling Incline,
Cooling Decline, Cooling Horizontal*



EC508 FG



Pitch:	50,8 mm / 2 inch
Belt Surface:	Open, Smooth Surface
Minimum Width:	200 mm / 7.87 inch
Open Area (%):	35%. (Biggest opening 9 x 12 mm)
Flight:	Yes (T25, T50, T75, T100, T150, TNC50, TNC100, TC75, TC100, TC150, TCC75, TCC100, TCC150, TCCH100)
Sidewall:	Yes (h=25 mm, h=50 mm, h=75 mm, h=100 mm)
Rod:	Ø7 mm / 0.276 inch - Self Lock
Approved:	FDA and EU
Curve:	No
Color:	Additional colors available
Cleanability:	Excellent
Belt Thickness:	16 mm / 0.630 inch

Product Features and Functional Benefits

- Belt provides optimal open area for drainage and airflow.
- Less friction and product contact for easy cooking, cooling and freezing of products.
- Reduced dirt and oxide build due to self cleaning surface.
- Easy to clean reduces downtime for cleaning time 70%.

Available Moulded Module Sizes

- 200 mm / **7.87 inch** module

EC508 FG / Technical Information

BELT MATERIAL	BELT STRENGTH				TEMPERATURE		BELT WEIGHT
	Straight		Curve		°C / °F (min.)	°C / °F (max.)	Kg/m ² / lb/ft ²
	N/m	lb/ft	N/m	lb/ft			
Polypropylene	17600	1205	-	-	+5 / +41	+90 / +194	7,5 / 1.54
Polyethylene	7700	528	-	-	-73 / -99.4	+66 / +150.8	8,0 / 1.65
Acetal	27500	1883	-	-	-43 / -45.4	+110 / +230	11,0 / 2.25

- Belt strength and temperature values are maximum on the table.

EC508 FG / Standard Belt Widths

BELT SERIES	WIDTH (W)				Belt With Tolerance (max.)
	PP-PE		POM		
	mm	inch	mm	inch	
EC 508 FG	200,0	7.87	200,0	7.87	± 1 mm
EC 508 FG	300,0	11.81	300,0	11.81	± 2 mm
EC 508 FG	400,0	15.75	400,0	15.75	± 2 mm
EC 508 FG	500,0	19.69	500,0	19.69	± 2 mm
EC 508 FG	600,0	23.62	600,0	23.62	± 3 mm
EC 508 FG	700,0	27.56	700,0	27.56	± 3 mm
EC 508 FG	800,0	31.50	800,0	31.50	± 3 mm
EC 508 FG	900,0	35.43	900,0	35.43	± 4 mm
EC 508 FG	1000,0	39.37	1000,0	39.37	± 4 mm
EC 508 FG	1100,0	43.31	1100,0	43.31	± 4 mm
EC 508 FG	1200,0	47.24	1200,0	47.24	± 4 mm
EC 508 FG	1300,0	51.18	1300,0	51.18	± 5 mm
EC 508 FG	1400,0	55.11	1400,0	55.11	± 5 mm
EC 508 FG	1500,0	59.06	1500,0	59.06	± 5 mm

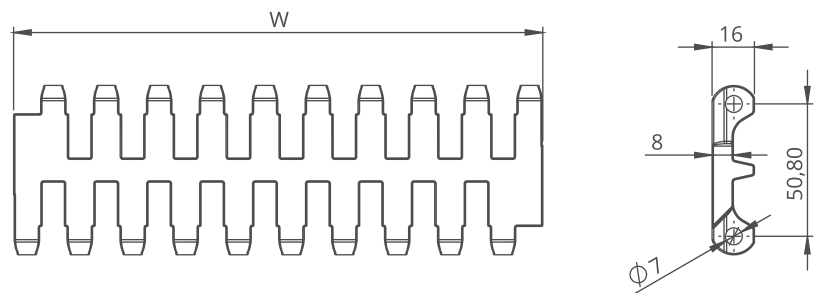

- Standard belt increments 100 mm.
- Non-standard belt increments 20 mm.
- Please contact with customer service for precise belt measurements.



EC508 FG-NT

Modular Belt Series

• Bakery Applications

*Oven Infeed/Outfeed, Cooling Lines, Coating Lines, Glazing Lines,
Freezing Lines, Conditioning Lines*

• Sea Food Applications

Breeding Machines, Draining Lines

• Snack Food Applications

Proofer Lines, Boiler Infeed, Oven Infeed / Outfeed, Cooling Lines

• Fruits and Vegetables Applications

Prewashing / Rinsing, Draining

• Tire Manufacturing Applications

*Mixer Infeed / Outfeed, Extrusion Shower Lines, Cooling Incline,
Cooling Decline, Cooling Horizontal*



EC508 FG-NT

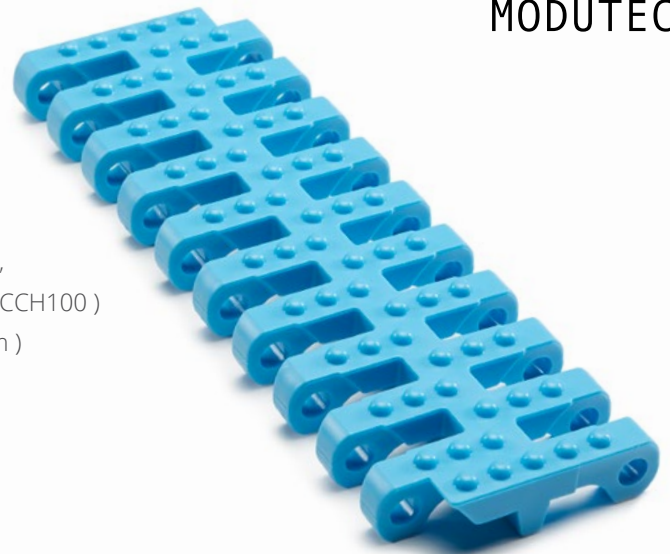

Pitch:	50,8 mm / 2 inch
Belt Surface:	Open, Nub Top Surface
Minimum Width:	200 mm / 7.87 inch
Open Area (%):	35%. (Biggest opening 9 x 12 mm)
Flight:	Yes (T25, T50, T75, T100, T150, TNC50, TNC100, TC75, TC100, TC150, TCC75, TCC100, TCC150, TCCH100)
Sidewall:	Yes (h=25 mm, h=50 mm, h=75 mm, h=100 mm)
Rod:	Ø7 mm / 0.275 inch - Self Lock
Approved:	FDA and EU
Curve:	No
Color:	Additional colors available
Cleanability:	Excellent
Belt Thickness:	18.5 mm / 0.728 inch

Product Features and Functional Benefits

- Belt provides optimal open area for drainage and airflow.
- Less friction and product contact for easy cooking, cooling and freezing of products.
- Non-adhesive due to reduced contact surface.
- Reduced dirt and oxide build due to self cleaning surface.
- Easy to clean reduces downtime for cleaning time 70%.

Available Moulded Module Sizes

- 200 mm / **7.87 inch** module
- 200 mm / **7.87 inch** edge module with 40 mm indent

EC508 FG-NT / Technical Information

BELT MATERIAL	BELT STRENGTH				TEMPERATURE		BELT WEIGHT
	Straight		Curve		°C (min.) - °F (min.)	°C (max.) - °F (max.)	Kg/m ² - lb/ft ²
	N/m	lb/ft	N/m	lb/ft			
Polypropylene	17600	1205	-	-	+5 / +42.8	+90 / +194	7,7 - 1.58
Polyethylene	7700	528	-	-	-73 / -99.4	+66 / +150.8	8,2 - 1.69
Acetal	27500	1883	-	-	-43 / -45.4	+110 / +230	11,4 - 2.33

EC508 FG-NT / Standard Belt Widths

- Belt strength and temperature values are maximum on the table.

BELT SERIES	WIDTH (W)				Belt With Tolerance (max.)
	PP-PE		POM		
	mm	inch	mm	inch	
EC 508 FG-NT	200,0	7.87	200,0	7.87	± 1 mm
EC 508 FG-NT	300,0	11.81	300,0	11.81	± 2 mm
EC 508 FG-NT	400,0	15.75	400,0	15.75	± 2 mm
EC 508 FG-NT	500,0	19.69	500,0	19.69	± 2 mm
EC 508 FG-NT	600,0	23.62	600,0	23.62	± 3 mm
EC 508 FG-NT	700,0	27.56	700,0	27.56	± 3 mm
EC 508 FG-NT	800,0	31.50	800,0	31.50	± 3 mm
EC 508 FG-NT	900,0	35.43	900,0	35.43	± 4 mm
EC 508 FG-NT	1000,0	39.37	1000,0	39.37	± 4 mm
EC 508 FG-NT	1100,0	43.31	1100,0	43.31	± 4 mm
EC 508 FG-NT	1200,0	47.24	1200,0	47.24	± 4 mm
EC 508 FG-NT	1300,0	51.18	1300,0	51.18	± 5 mm
EC 508 FG-NT	1400,0	55.11	1400,0	55.11	± 5 mm
EC 508 FG-NT	1500,0	59.06	1500,0	59.06	± 5 mm

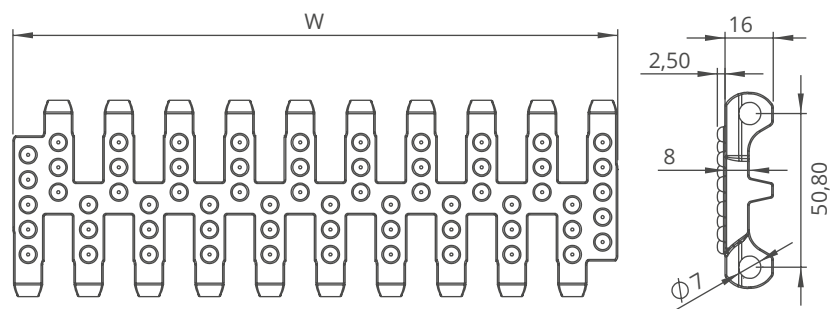

- Standard belt increments 100 mm.
- Non-standard belt increments 20 mm.
- Please contact with customer service for precise belt measurements.



EC508 PR%11

Modular Belt Series

• Meat Applications

Dressing Lines, Trim Lines, Elevator, Metal Detector

• Poultry Applications

Cut-up Lines, Debonning Lines, Chiller Discharge, Rehang / Bird Accumulation, Freezing Lines, Elevators

• Sea Food Applications

Draining, Elevator

• Snack Food Applications

Can Draining

• Fruits and Vegetables Applications

Prewashing / Rinsing, Draining, Peeling, Elevator



EC508 PR%11

Pitch:	50,8 mm / 2 inch
Belt Surface:	Open, Mesh Top Surface
Minimum Width:	200 mm / 7.87 inch
Open Area (%):	11%. (Biggest opening 1,2 x 12 mm)
Flight:	Yes (T25, T50, T75, T100, T150, TNC50, TNC100, TC75, TC100, TC150, TCC75, TCC100, TCC150, TCCH100)
Sidewall:	Yes (h=25 mm, h=50 mm, h=75 mm, h=100 mm)
Rod:	Ø7 mm / 0.276 inch - Self Lock
Approved:	FDA and EU
Curve:	No
Color:	Additional colors available
Cleanability:	Excellent
Belt Thickness:	16 mm / 0.630 inch

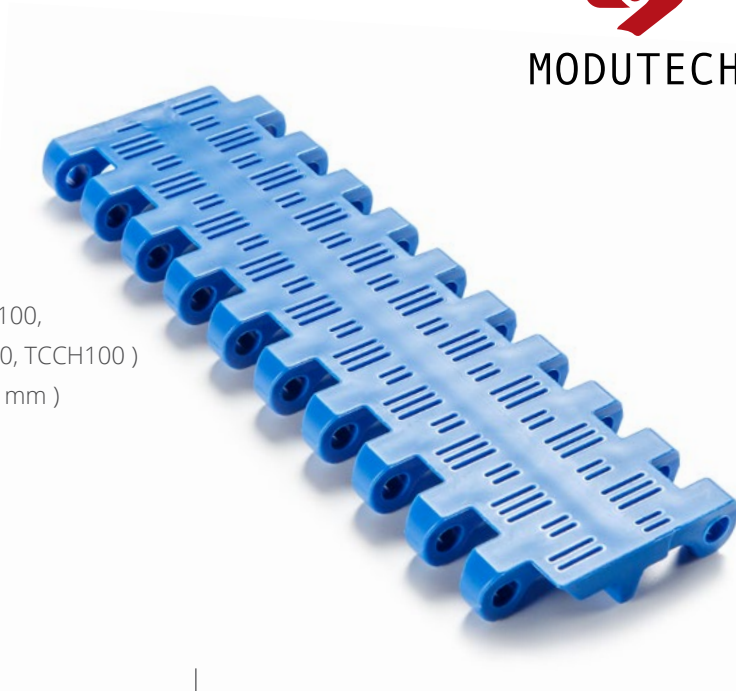

Product Features and Functional Benefits

- Unique sprocket engagement - precise indexing, easy cleaning.
- Different openings to optimize performance in cooling and draining applications.
- Easy to clean reduces downtime for cleaning time 70%.
- Unique sprocket engagement - higher product load and longer conveyors.
- Reduces bacteria growth.

Available Moulded Module Sizes

- 200 mm / **7.87 inch** module

EC508 PR%11 / Technical Information

BELT MATERIAL	BELT STRENGTH				TEMPERATURE		BELT WEIGHT
	Straight		Curve		°C / °F (min.)	°C / °F (max.)	Kg/m ² / lb/ft ²
	N/m	lb/ft	N/m	lb/ft			
Polypropylene	19800	1356	-	-	+5 / +41	+90 / +194	7,8 / 1.60
Polyethylene	-	-	-	-	-	-	-
Acetal	-	-	-	-	-	-	-

- Belt strength and temperature values are maximum on the table.

EC508 PR%11 / Standard Belt Widths

BELT SERIES	WIDTH (W)				Belt With Tolerance (max.)
	PP		POM		
	mm	inch	mm	inch	
EC508 PR11	200,0	7.87	-	-	± 1 mm
EC508 PR11	300,0	11.81	-	-	± 2 mm
EC508 PR11	400,0	15.75	-	-	± 2 mm
EC508 PR11	500,0	19.69	-	-	± 2 mm
EC508 PR11	600,0	23.62	-	-	± 3 mm
EC508 PR11	700,0	27.56	-	-	± 3 mm
EC508 PR11	800,0	31.50	-	-	± 3 mm
EC508 PR11	900,0	35.43	-	-	± 4 mm
EC508 PR11	1000,0	39.37	-	-	± 4 mm
EC508 PR11	1100,0	43.31	-	-	± 4 mm
EC508 PR11	1200,0	47.24	-	-	± 4 mm
EC508 PR11	1300,0	51.18	-	-	± 5 mm
EC508 PR11	1400,0	55.11	-	-	± 5 mm
EC508 PR11	1500,0	59.06	-	-	± 5 mm

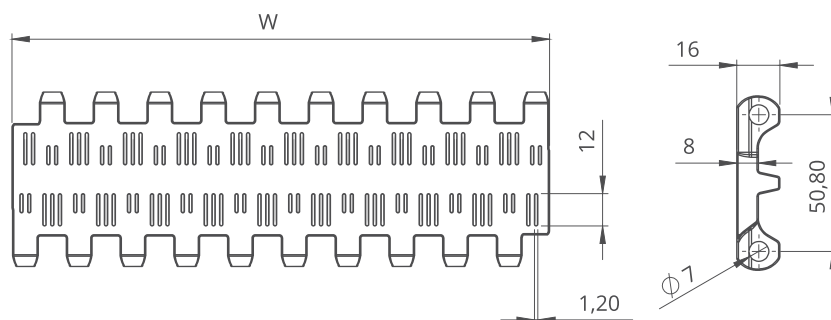

- Standard belt increments 100 mm.
- Non-standard belt increments 20 mm.
- Please contact with customer service for precise belt measurements.



EC508 PR%13

Modular Belt Series

• Poultry Applications

Cut-up Lines, Debonning Lines, Chiller Discharge, Rehang / Bird Accumulation, Freezing Lines, Elevators

• Sea Food Applications

Draining, Elevator

• Snack Food Applications

Can Draining

• Fruits and Vegetables Applications

Prewashing / Rinsing, Draining, Peeling, Elevator



EC508 PR%13

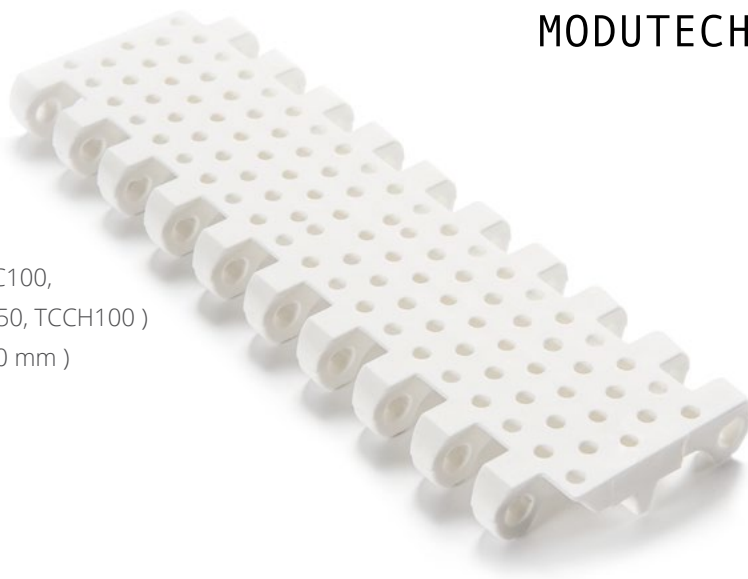

Pitch:	50,8 mm / 2 inch
Belt Surface:	Open, Smooth Surface
Minimum Width:	200 mm / 7.87 inch
Open Area (%):	13%. (Biggest opening Ø3,8 mm)
Flight:	Yes (T25, T50, T75, T100, T150, TNC50, TNC100, TC75, TC100, TC150, TCC75, TCC100, TCC150, TCCH100)
Sidewall:	Yes (h=25 mm, h=50 mm, h=75 mm, h=100 mm)
Rod:	Ø7 mm / 0.276 inch - Self Lock
Approved:	FDA and EU
Curve:	No
Color:	Additional colors available
Cleanability:	Excellent
Belt Thickness:	16 mm / 0.630 inch

Product Features and Functional Benefits

- Unique sprocket engagement - precise indexing, easy cleaning.
- Different openings to optimize performance in cooling and draining applications.
- Easy to clean reduces downtime for cleaning time 70%.
- Unique sprocket engagement - higher product load and longer conveyors.
- Reduces bacteria growth.

Available Moulded Module Sizes

- 200 mm / **7.87 inch** module

EC508 PR%13 / Technical Information

BELT MATERIAL	BELT STRENGTH				TEMPERATURE		BELT WEIGHT
	Straight		Curve		°C / °F (min.)	°C / °F (max.)	Kg/m ² / lb/ft ²
	N/m	lb/ft	N/m	lb/ft			
Polypropylene	19800	1356	-	-	+5 / +41	+90 / +194	7,5 / 1.54
Polyethylene	11000	753	-	-	-73 / -99.4	+66 / +150.8	7,8 / 1.59
Acetal	33000	2260	-	-	-43 / -45.4	+110 / +230	11,2 / 2.28

- Belt strength and temperature values are maximum on the table.

EC508 PR%13 / Standard Belt Widths

BELT SERIES	WIDTH (W)				Belt With Tolerance (max.)
	PP-PE		POM		
	mm	inch	mm	inch	
EC508 PR13	200,0	7.87	200,0	7.87	± 1 mm
EC508 PR13	300,0	11.81	300,0	11.81	± 2 mm
EC508 PR13	400,0	15.75	400,0	15.75	± 2 mm
EC508 PR13	500,0	19.69	500,0	19.69	± 2 mm
EC508 PR13	600,0	23.62	600,0	23.62	± 3 mm
EC508 PR13	700,0	27.56	700,0	27.56	± 3 mm
EC508 PR13	800,0	31.50	800,0	31.50	± 3 mm
EC508 PR13	900,0	35.43	900,0	35.43	± 4 mm
EC508 PR13	1000,0	39.37	1000,0	39.37	± 4 mm
EC508 PR13	1100,0	43.31	1100,0	43.31	± 4 mm
EC508 PR13	1200,0	47.24	1200,0	47.24	± 4 mm
EC508 PR13	1300,0	51.18	1300,0	51.18	± 5 mm
EC508 PR13	1400,0	55.11	1400,0	55.11	± 5 mm
EC508 PR13	1500,0	59.06	1500,0	59.06	± 5 mm

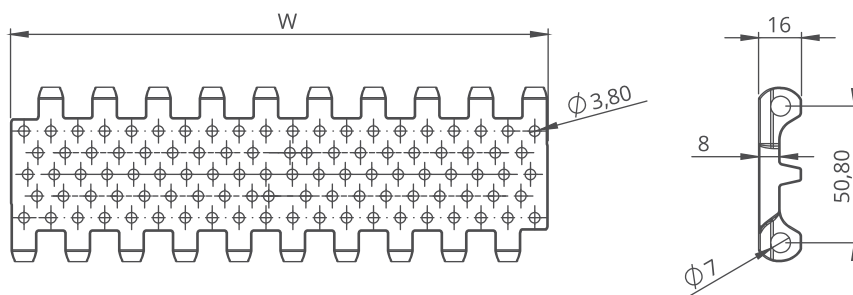

- Standard belt increments 100 mm.
- Non-standard belt increments 20 mm.
- Please contact with customer service for precise belt measurements.



EC508 DT

Modular Belt Series

• Meat Applications

*Slaughtering / Evisceration, Cutting Lines, Deboning Lines,
Bone Takeaway, Dressing Lines, Trim Lines*

• Poultry Applications

*Live Birds, Slaughtering / Evisceration, Skining, Cut-up, Chiller Discharge,
Bird Accumulation, Freezing Lines, Elevators*

• Sea Food Applications

Trim Lines, Control Tables, Glazing, Elevators

• Fruits and Vegetables Applications

Bulk Feeding, Elevators, Control Sorting Table, Filling



EC508 DT

Pitch:	50,8 mm / 2 inch
Belt Surface:	Close, Diamond Top Surface
Minimum Width:	200 mm / 7.87 inch
Open Area (%):	0%
Flight:	Yes (T25, T50, T75, T100, T150, TNC50, TNC100, TC75, TC100, TC150, TCC75, TCC100, TCC150, TCCH100)
Sidewall:	Yes (h=25 mm, h=50 mm, h=75 mm, h=100 mm)
Rod:	Ø7 mm / 0.276 inch - Self Lock
Approved:	FDA and EU
Curve:	No
Color:	Additional colors available
Cleanability:	Excellent
Belt Thickness:	17 mm / 0.669 inch

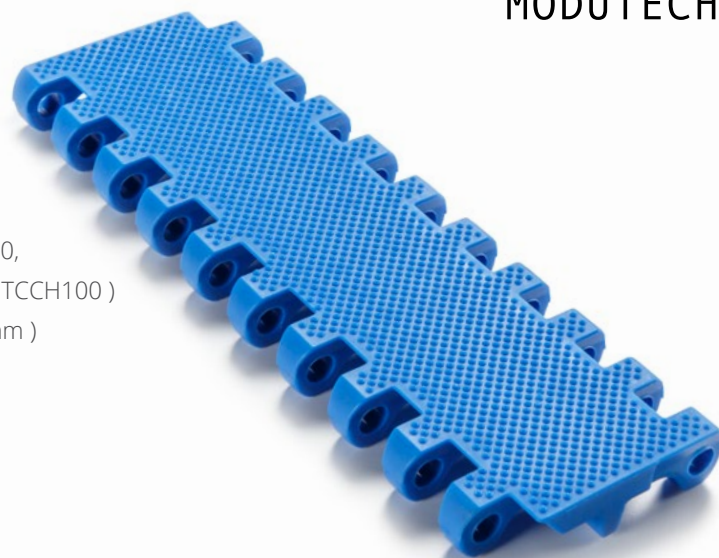

Product Features and Functional Benefits

- Easy to clean reduces downtime for cleaning time 70%.
- Close, sticky transfer applications. Non-adhesive due to reduced contact surface.
- Reduces bacteria growth.
- Unique sprocket engagement - higher product load and longer conveyors.
- Strong and thick product supports allow more load without breaking.
- Impact resistance to withstand heavy objects falling into the belt.

Available Moulded Module Sizes

- 200 mm / **7.87 inch** module
- 200 mm / **7.87 inch** edge module with 40 mm indent
- 100 mm / **3,94 inch** edge module with 40 mm indent

EC508 DT / Technical Information

BELT MATERIAL	BELT STRENGTH				TEMPERATURE		BELT WEIGHT Kg/m ² / lb/ft ²
	Straight		Curve		°C / °F (min.)	°C / °F (max.)	
	N/m	lb/ft	N/m	lb/ft			
Polypropylene	19800	1356	-	-	+5 / +41	+90 / +194	9,1 / 1.86
Polyethylene	11000	753	-	-	-73 / -99.4	+66 / +150.8	9,5 / 1.95
Acetal	33000	2260	-	-	-43 / -45.4	+110 / +230	13,6 / 2.79

- Belt strength and temperature values are maximum on the table.

EC508 DT / Standard Belt Widths

BELT SERIES	WIDTH (W)				Belt With Tolerance (max.)
	PP-PE		POM		
	mm	inch	mm	inch	
EC508 DT	200,0	7.87	200,0	7.87	± 1 mm
EC508 DT	300,0	11.81	300,0	11.81	± 2 mm
EC508 DT	400,0	15.75	400,0	15.75	± 2 mm
EC508 DT	500,0	19.69	500,0	19.69	± 2 mm
EC508 DT	600,0	23.62	600,0	23.62	± 3 mm
EC508 DT	700,0	27.56	700,0	27.56	± 3 mm
EC508 DT	800,0	31.50	800,0	31.50	± 3 mm
EC508 DT	900,0	35.43	900,0	35.43	± 4 mm
EC508 DT	1000,0	39.37	1000,0	39.37	± 4 mm
EC508 DT	1100,0	43.31	1100,0	43.31	± 4 mm
EC508 DT	1200,0	47.24	1200,0	47.24	± 4 mm
EC508 DT	1300,0	51.18	1300,0	51.18	± 5 mm
EC508 DT	1400,0	55.11	1400,0	55.11	± 5 mm
EC508 DT	1500,0	59.06	1500,0	59.06	± 5 mm

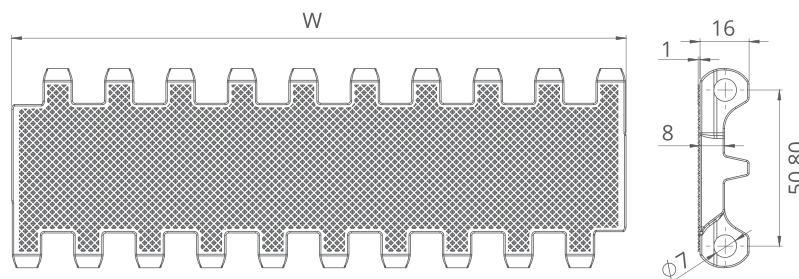

- Standard belt increments 100 mm.
- Non-standard belt increments 20 mm.
- Please contact with customer service for precise belt measurements.



EC508 NT

Modular Belt Series

• Meat Applications

*Slaughtering / Evisceration, Cutting Lines, Deboning Lines,
Bone Takeaway, Dressing Lines, Trim Lines*

• Poultry Applications

*Live Birds, Slaughtering / Evisceration, Skining, Cut-up, Chiller Discharge,
Bird Accumulation, Freezing Lines, Elevators*

• Sea Food Applications

Trim Lines, Control Tables, Glazing, Elevators

• Fruits and Vegetables Applications

Bulk Feeding, Elevators, Control Sorting Table, Filling



EC508 NT

Pitch:	50,8 mm / 2 inch
Belt Surface:	Close, Nub Top Surface
Minimum Width:	200 mm / 7.87 inch
Open Area (%):	0%
Flight:	Yes (T25, T50, T75, T100, T150, TNC50, TNC100, TC75, TC100, TC150, TCC75, TCC100, TCC150, TCCH100)
Sidewall:	Yes (h=25 mm, h=50 mm, h=75 mm, h=100 mm)
Rod:	Ø7 mm / 0.275 inch - Self Lock
Approved:	FDA and EU
Curve:	No
Color:	Additional colors available
Cleanability:	Excellent
Belt Thickness:	18,5 mm / 0.728 inch

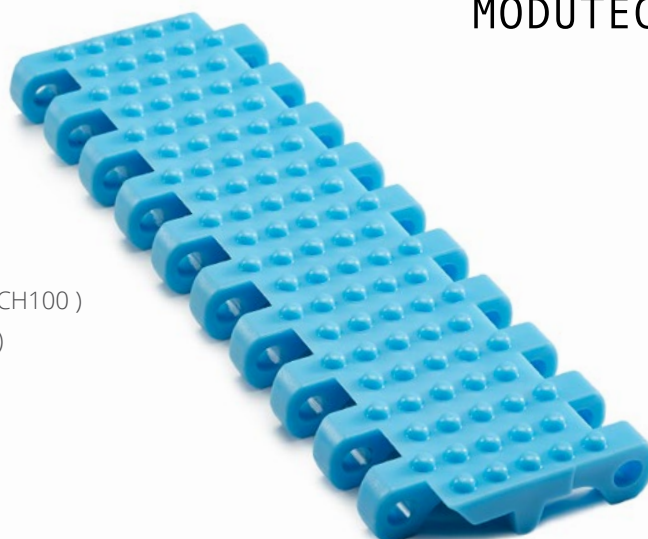

Product Features and Functional Benefits

- Easy to clean reduces downtime for cleaning time 70%.
- Close, sticky transfer applications. Non-adhesive due to reduced contact surface.
- Reduces bacteria growth.
- Unique sprocket engagement - higher product load and longer conveyors.
- Strong and thick product supports allow more load without breaking.
- Impact resistance to withstand heavy objects falling into the belt.

Available Moulded Module Sizes

- 200 mm / **7.87 inch** module
- 200 mm / **7.87 inch** edge module with 40 mm indent

EC508 NT / Technical Information

BELT MATERIAL	BELT STRENGTH				TEMPERATURE		BELT WEIGHT
	Straight		Curve		°C (min.) - °F (min.)	°C (max.) - °F (max.)	Kg/m ² - lb/ft ²
	N/m	lb/ft	N/m	lb/ft			
Polypropylene	-	-	-	-	-	-	-
Polyethylene	11000	753	-	-	-73 / -99.4	+66 / +150.8	9,6 - 1.97
Acetal	33000	2260	-	-	-43 / -45.4	+110 / +230	13,9 - 2.85

- Belt strength and temperature values are maximum on the table.

EC508 NT / Standard Belt Widths

BELT SERIES	WIDTH (W)				Belt With Tolerance (max.)
	PE		POM		
	mm	inch	mm	inch	
EC508 NT	200,0	7.87	200,0	7.87	± 1 mm
EC508 NT	300,0	11.81	300,0	11.81	± 2 mm
EC508 NT	400,0	15.75	400,0	15.75	± 2 mm
EC508 NT	500,0	19.69	500,0	19.69	± 2 mm
EC508 NT	600,0	23.62	600,0	23.62	± 3 mm
EC508 NT	700,0	27.56	700,0	27.56	± 3 mm
EC508 NT	800,0	31.50	800,0	31.50	± 3 mm
EC508 NT	900,0	35.43	900,0	35.43	± 4 mm
EC508 NT	1000,0	39.37	1000,0	39.37	± 4 mm
EC508 NT	1100,0	43.31	1100,0	43.31	± 4 mm
EC508 NT	1200,0	47.24	1200,0	47.24	± 4 mm
EC508 NT	1300,0	51.18	1300,0	51.18	± 5 mm
EC508 NT	1400,0	55.11	1400,0	55.11	± 5 mm
EC508 NT	1500,0	59.06	1500,0	59.06	± 5 mm

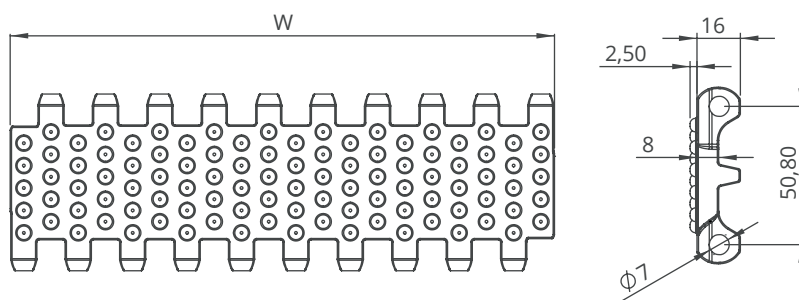

- Standard belt increments 100 mm.
- Non-standard belt increments 20 mm.
- Please contact with customer service for precise belt measurements.

EC508 Series Sprockets and Technical Specifications

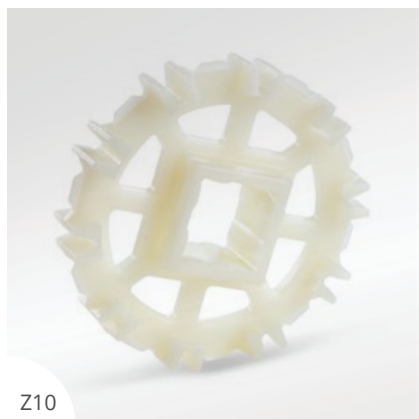

Z10



Z10



Z12

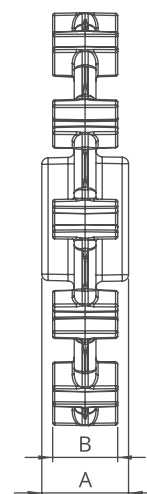
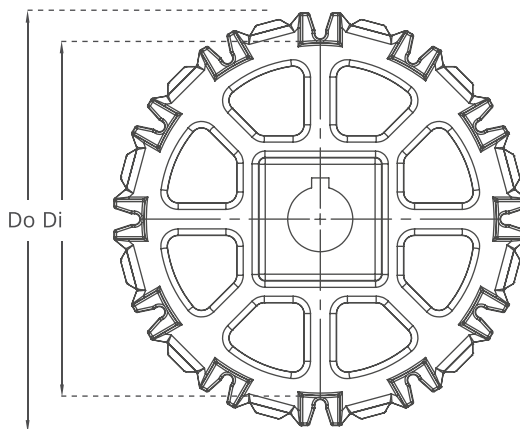
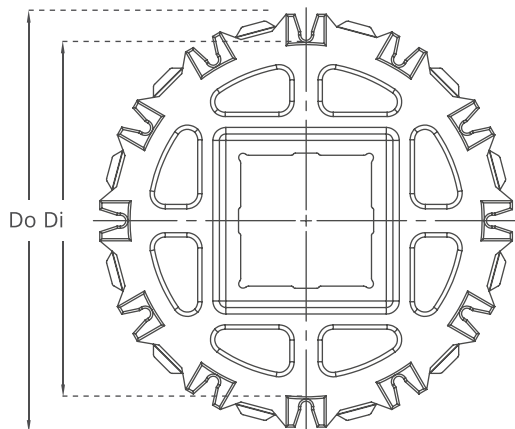

EC508 Series / Standard Sprockets Dimensions

NO. TEETH	Di mm/inch	Do mm/inch	B mm/inch	A mm/inch	Square Bore(Q) mm/inch	Round Bore(R) mm/inch	PRODUCT CODE	
							Square Type (Q)	Round Type (R)
Z6	73,0 / 2.87	90,0 / 3.54	30 / 1.18	40 / 1.57	40 / 1.5	25-30 / 1-1.25	EC508SQZ6*PA	EC508SRZ6*PA
Z8	107,5 / 4.23	124,5 / 4.90	30 / 1.18	40 / 1.57	40 / 1.5	25-30 / 1-1.25	EC508SQZ8*PA	EC508SRZ8*PA
Z10	141,5 / 5.57	158,0 / 6.22	30 / 1.18	40 / 1.57	40-60 / 1.5-2.5	25-30 / 1-1.25	EC508SQZ10*PA	EC508SRZ10*PA
Z12	175,2 / 6.90	191,2 / 7.53	30 / 1.18	40 / 1.57	40-60 / 1.5-2.5	25-30 / 1-1.25	EC508SQZ12*PA	EC508SRZ12*PA

*Other sprockets and hub sizes are manufactured up to request.

*POM (Acetal) and PP (Polypropylene) sprockets raw material is available on request.

***Machined Split Sprockets are available for each size.**



Clamp



Machined Split Sprocket



Moulded Sprocket

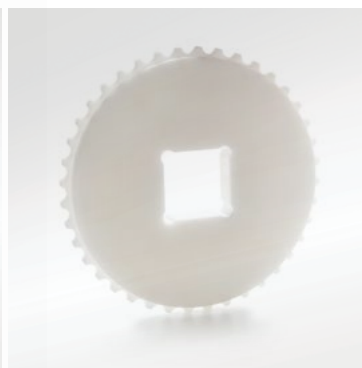

Machined Sprocket



MODUTECH

EC508 Series Accessories and Technical Specifications

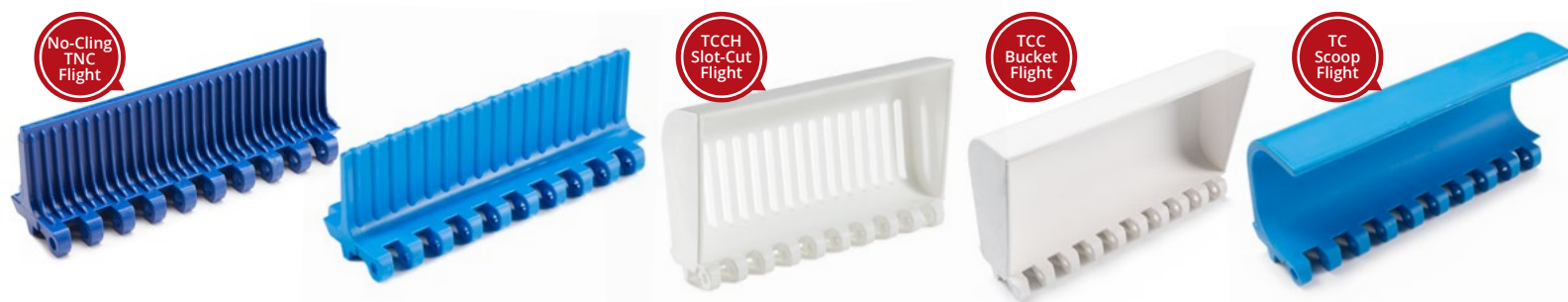

EC508 Series / Flight & Sidewall Dimensions

EC508 Series / Flights & Sidewalls				
PRODUCT CODE	Flight Height (mm/ <i>inch</i>)	Flight Width (mm/ <i>inch</i>)	PRODUCT CODE	Sidewall Height (mm/ <i>inch</i>)
EC508T25	25 / 1	200 / 7.87	EC508SW25	25 / 1
EC508T50	50 / 2	200 / 7.87	EC508SW50	50 / 2
EC508T75	75 / 3	200 / 7.87	EC508SW75	75 / 3
EC508T100	100 / 4	200 / 7.87	EC508SW100	100 / 4
EC508T150	150 / 6	200 / 7.87	-	-
EC508TC75	75 / 3	200 / 7.87	-	-
EC508TC100	100 / 4	200 / 7.87	-	-
EC508TC150	150 / 6	200 / 7.87	-	-
EC508TCC75	75 / 3	200 / 7.87	-	-
EC508TCC100	100 / 4	200 / 7.87	-	-
EC508TCC150	150 / 6	200 / 7.87	-	-
EC508TNC100	100 / 4	200 / 7.87	-	-
EC508TCH100	100 / 4	200 / 7.87	-	-
EC508TCCH100	100 / 4	200 / 7.87	-	-

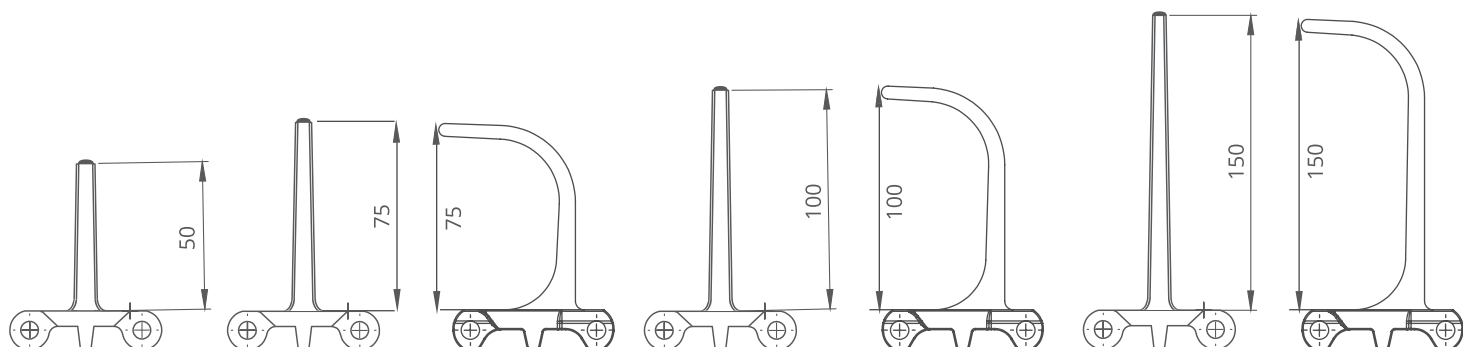

* Additional flight dimensions are available up to 150 mm.

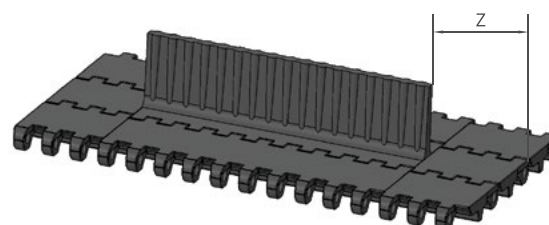
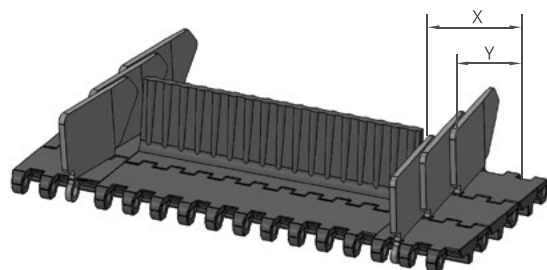

EC508 Series / Sidewall Technical Specifications

Possible Sidewall and Flight Indents	X		Y	
	mm	<i>inch</i>	mm	<i>inch</i>
Standard, no module cutting	32,0	1.26	20,0	0.79
Module cutting necessary	42,0	1.65	30,0	1.18
Standard, no module cutting	52,0	2.05	40,0	1.57
Module cutting necessary	62,0	2.44	50,0	1.97
Standard, no module cutting	72,0	2.83	60,0	2.36
Module cutting necessary	82,0	3.23	70,0	2.76

EC508 Series / Flight Technical Specifications

Possible Flight Indents for EC508 Series	Z	
	mm	<i>inch</i>
Standard, no module cutting	40,0	1.57
Standard, no module cutting	60,0	2.36
Standard, module cutting	80,0	3.15
Standard, no module cutting	100,0	3.94

*Non-standard flight indent is on request.

Note: Gap between flight and sidewall minimum 2-3 mm

EC508 Series *Engineering Information*

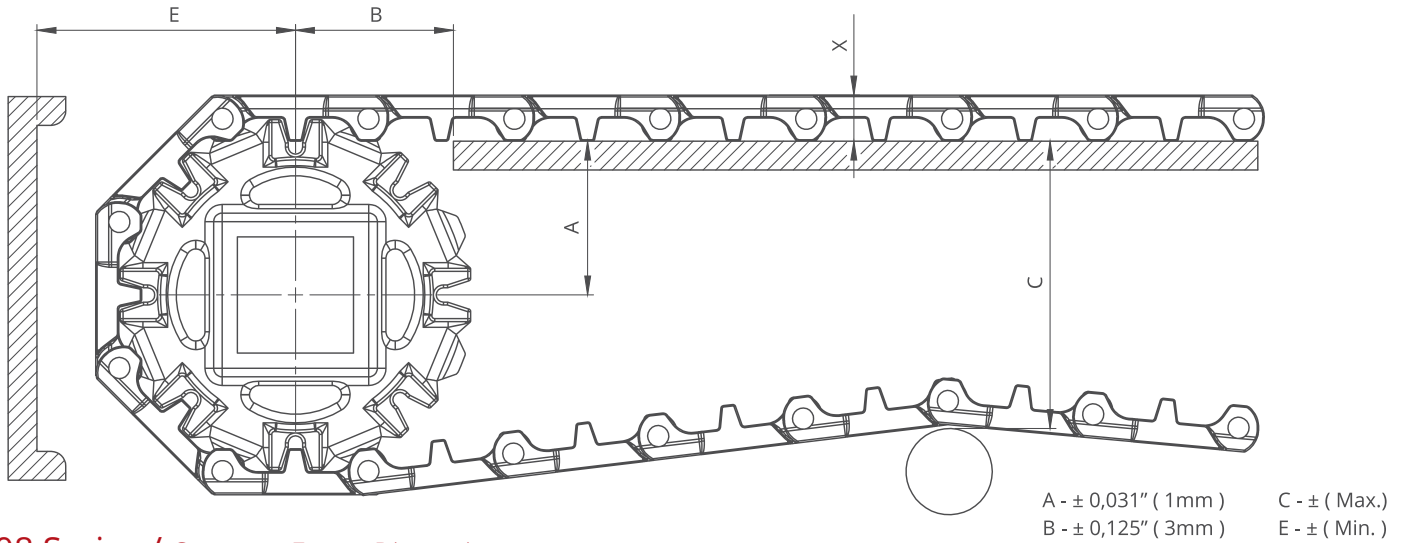

EC508 Series / Conveyor Frame Dimensions

Sprockets Description			A		B		C		E		X	
Pitch Diameter		No.Teeth	Range (Bottom to Top)		inch	mm	inch	mm	inch	mm	inch	mm
inch	mm		inch	mm								
EC508 C, EC508 PR%22, EC508 PR%13, EC508 PR%11, EC508 FG												
3.23	82,0	6	1.70	43,3	1.72	43,8	2.92	74,3	2.73	69,3	0.63	16,0
4.57	116,0	8	2.34	59,4	2.08	52,7	4.23	107,4	3.36	85,4	0.63	16,0
5.91	150,0	10	2.96	75,3	2.38	60,5	5.52	140,3	3.99	101,3	0.63	16,0
7.23	183,6	12	3.65	92,8	2.58	65,5	6.87	174,6	4.68	118,8	0.63	16,0
EC508 DT												
3.23	82,0	6	1.70	43,3	1.72	43,8	2.92	74,3	2.73	69,3	0.67	17,0
4.57	116,0	8	2.34	59,4	2.08	52,7	4.23	107,4	3.36	85,4	0.67	17,0
5.91	150,0	10	2.96	75,3	2.38	60,5	5.52	140,3	3.99	101,3	0.67	17,0
7.23	183,6	12	3.65	92,8	2.58	65,5	6.87	174,6	4.68	118,8	0.67	17,0
EC508 NT, EC508 FG-NT												
3.23	82,0	6	1.70	43,3	1.72	43,8	2.83	71,8	2.83	71,8	0.73	18,5
4.57	116,0	8	2.34	59,4	2.08	52,7	4.13	104,9	3.46	87,9	0.73	18,5
5.91	150,0	10	2.96	75,3	2.38	60,5	5.43	137,8	4.09	103,8	0.73	18,5
7.23	183,6	12	3.65	92,8	2.58	65,5	6.78	172,1	4.78	121,3	0.73	18,5

EC508 Series / Slider Support System For Straight Running Belts

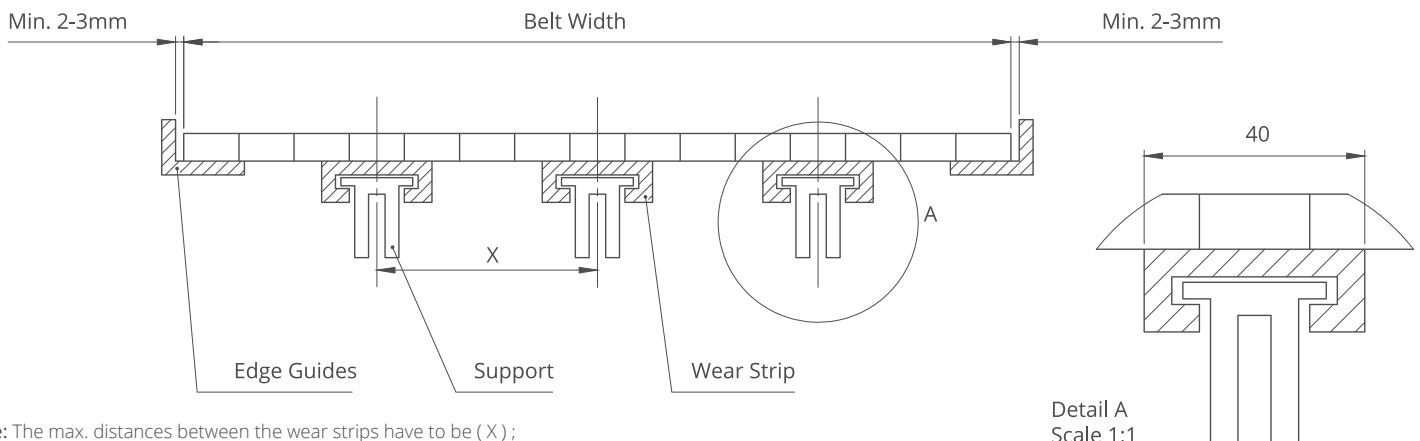

Note: The max. distances between the wear strips have to be (X) ;
 125 mm for 2" belts. 80 mm for 1" / 0.5" belts.

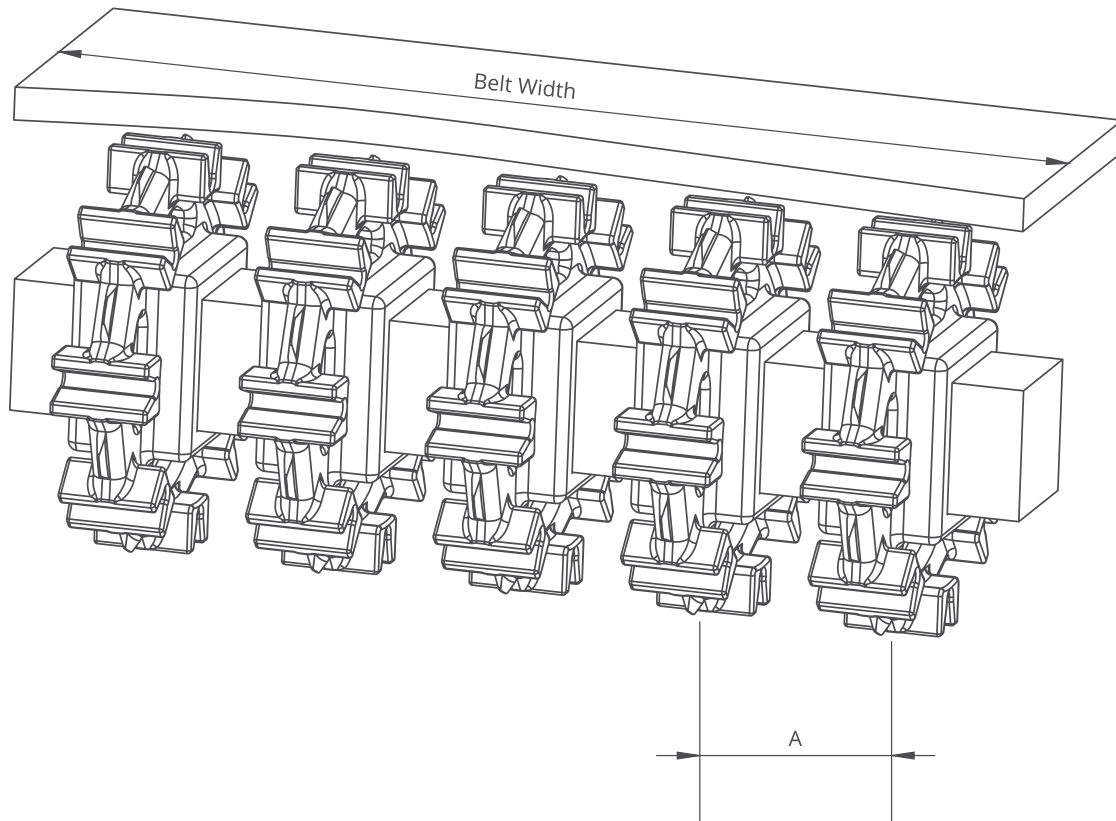

EC508 Series / Sprockets Arrangement

Standard Belt Width		Number of sprockets per shaft		A (mm/inch)	
mm	inch	Drive Shaft	Return Shaft	Min.	Max.
200,0	7.9	2	2	60/2.36	150/5.9
300,0	11.8	3	2	60/2.36	150/5.9
400,0	15.7	3	3	60/2.36	150/5.9
500,0	19.7	4	3	60/2.36	150/5.9
600,0	23.6	4	3	60/2.36	150/5.9
700,0	27.6	5	4	60/2.36	150/5.9
800,0	31.5	6	4	60/2.36	150/5.9
900,0	35.4	6	5	60/2.36	150/5.9
1000,0	39.4	7	5	60/2.36	150/5.9
1100,0	43.3	7	5	60/2.36	150/5.9
1200,0	47.2	8	6	60/2.36	150/5.9
1400,0	55.1	9	7	60/2.36	150/5.9
1600,0	63.0	10	7	60/2.36	150/5.9
1800,0	70.9	11	8	60/2.36	150/5.9
2000,0	78.7	12	8	60/2.36	150/5.9
2200,0	86.6	13	9	60/2.36	150/5.9
2400,0	94.5	14	10	60/2.36	150/5.9
2600,0	102.4	15	10	60/2.36	150/5.9
2800,0	110.2	16	11	60/2.36	150/5.9
3000,0	118.1	17	12	60/2.36	150/5.9

Note: Number of sprockets depends on the belt load.

MD508

Modular Belt Series

MD508 C

MD508 FG

MD508 PR%25

Sprockets & Accessories

Engineering Information







MD508 C

Modular Belt Series

• ***Corrugated Cardbord Applications***
Down Stackers, Corrugator Take Off, Strap Feed

• ***Lumber Industry***
Lumber Transport, Cutting Process

• ***Snack Food Applications***
Potato Processing

• ***Fruits and Vegetables Applications***
Bulk Feeding, Elevator, Control Sorting Table, Filling

• ***Automotive Applications***
Chair Lift - Feeder

• ***Packaging Applications***
Bluk Inclines, Box Transport Horizontal



MD508 C (Heavy Duty Food Belts)

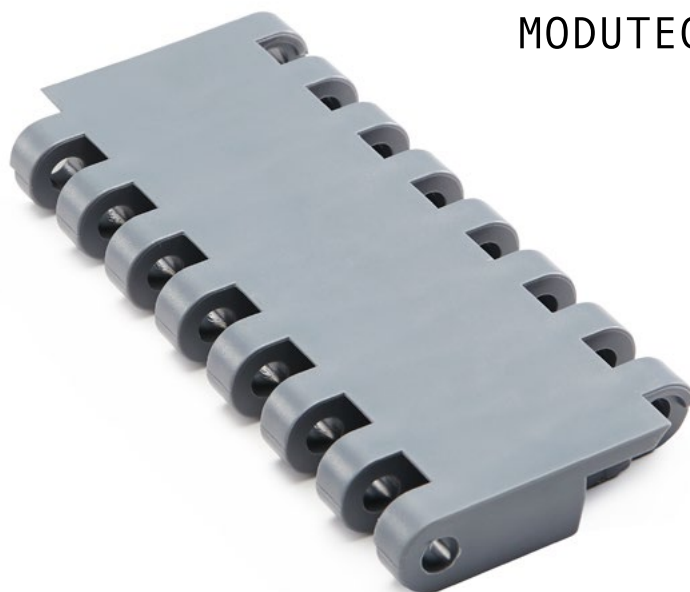

Pitch:	50,8 mm / 2 inch
Belt Surface:	Close, Smooth Surface
Minimum Width:	150 mm / 5.90 inch
Open Area (%):	0%
Flight:	Yes (T50, T100, T150)
Sidewall:	No
Rod:	Ø7 mm / 0.275 inch - Self Lock
Approved:	FDA and EU
Curve:	No
Color:	Additional colors available
Cleanability:	Good
Belt Thickness:	16 mm / 0.629 inch

Product Features and Functional Benefits

- Unique sprocket engagement reduces pulsation and increases load capacity.
- High power, bi-directional belt for long conveyors.
- Unique sprocket engagement - higher product load and longer conveyors.
- Strong and thick product supports allow more load without breaking.
- Impact resistance to with stand heavy objects falling into the belt.

Available Moulded Module Sizes

- 150 mm / **5.90 inch** module

MD508 C / Technical Information

BELT MATERIAL	BELT STRENGTH				TEMPERATURE		BELT WEIGHT
	Straight		Curve		°C / °F (min.)	°C / °F (max.)	Kg/m ² / lb/ft ²
	N/m	lb/ft	N/m	lb/ft			
Polypropylene	37400	2562	-	-	+5 / +41	+90 / +194	8,7 / 1.78
Polyethylene	26400	1808	-	-	-73 / -99.4	+66 / +150.8	9,3 / 1.90
Acetal	66000	4522	-	-	-43 / -45.4	+110 / +230	13,5 / 2.77

- Belt strength and temperature values are maximum on the table.

MD508 C / Standard Belt Widths

BELT SERIES	WIDTH (W)				Belt With Tolerance (max.)
	PP-PE		POM		
	mm	inch	mm	inch	
MD508 C	150,0	5.91	150,0	5.91	± 0,5 mm
MD508 C	225,0	8.86	225,0	8.86	± 2 mm
MD508 C	300,0	11.81	300,0	11.81	± 2 mm
MD508 C	375,0	14.76	375,0	14.76	± 2 mm
MD508 C	450,0	17.72	450,0	17.72	± 3 mm
MD508 C	525,0	20.67	525,0	20.67	± 3 mm
MD508 C	600,0	23.62	600,0	23.62	± 3 mm
MD508 C	675,0	26.57	675,0	26.57	± 3 mm
MD508 C	750,0	29.53	750,0	29.53	± 4 mm
MD508 C	825,0	32.48	825,0	32.48	± 4 mm
MD508 C	900,0	35.43	900,0	35.43	± 4 mm
MD508 C	975,0	38.38	975,0	38.38	± 5 mm
MD508 C	1050,0	41.34	1050,0	41.34	± 5 mm
MD508 C	1125,0	44.29	1125,0	44.29	± 5 mm

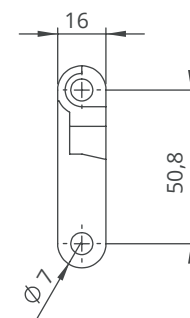
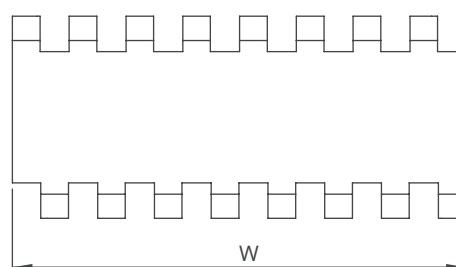

- Standard belt increments 75 mm.
- Non-standard belt increments 18,75 mm.
- Please contact with customer service for precise belt measurements.



MD508 FG

Modular Belt Series

• Bakery Applications

Oven Infeed/Outfeed, Cooling Lines, Coating Lines, Glazing Lines,
Freezing Lines, Conditioning Lines

• Sea Food Applications

Breeding Machines, Draining Lines

• Snack Food Applications

Proofer Lines, Boiler Infeed, Oven Infeed / Outfeed, Cooling Lines

• Fruits and Vegetables Applications

Prewashing / Rinsing, Draining

• Tire Manufacturing Applications

Mixer Infeed / Outfeed, Extrusion Shower Lines, Cooling Incline,
Cooling Decline, Cooling Horizontal



MD508 FG (Heavy Duty Food Belts)



Pitch:	50,8 mm / 2 inch
Belt Surface:	Open, Smooth Surface
Minimum Width:	150 mm / 5.90 inch
Open Area (%):	34%. (Biggest opening 6 x 19,8 mm)
Flight:	Yes (T50, T100, T150)
Sidewall:	No
Rod:	Ø7 mm / 0.275 inch - Self Lock
Approved:	FDA and EU
Curve:	No
Color:	Additional colors available
Cleanability:	Good
Belt Thickness:	16 mm / 0.629 inch

Product Features and Functional Benefits

- Belt provides optimal open area for drainage and airflow.
- Unique sprocket engagement reduces pulsation and increases load capacity.
- High power, bi-directional belt for long conveyors.
- Unique sprocket engagement - higher product load and longer conveyors.
- Strong and thick product supports allow more load without breaking.
- Impact resistance to with stand heavy objects falling on the belt.

Available Moulded Module Sizes

- 150 mm / **5.90 inch** module

MD508 FG / Technical Information

BELT MATERIAL	BELT STRENGTH				TEMPERATURE		BELT WEIGHT
	Straight		Curve		°C / °F (min.)	°C / °F (max.)	Kg/m ² / lb/ft ²
	N/m	lb/ft	N/m	lb/ft			
Polypropylene	28600	1959	-	-	+5 / +41	+90 / +194	6,8 / 1.39
Polyethylene	19800	1356	-	-	-73 / -99.4	+66 / +150.8	7,2 / 1.48
Acetal	38500	2637	-	-	-43 / -45.4	+110 / +230	10,2 / 2.09

- Belt strength and temperature values are maximum on the table.

MD508 FG / Standard Belt Widths

BELT SERIES	WIDTH (W)				Belt With Tolerance (max.)
	PP-PE		POM		
	mm	inch	mm	inch	
MD508 FG	150,0	5.91	150,0	5.91	± 1 mm
MD508 FG	225,0	8.86	225,0	8.86	± 2 mm
MD508 FG	300,0	11.81	300,0	11.81	± 2 mm
MD508 FG	375,0	14.76	375,0	14.76	± 2 mm
MD508 FG	450,0	17.72	450,0	17.72	± 3 mm
MD508 FG	525,0	20.67	525,0	20.67	± 3 mm
MD508 FG	600,0	23.62	600,0	23.62	± 3 mm
MD508 FG	675,0	26.57	675,0	26.57	± 4 mm
MD508 FG	750,0	29.53	750,0	29.53	± 4 mm
MD508 FG	825,0	32.48	825,0	32.48	± 4 mm
MD508 FG	900,0	35.43	900,0	35.43	± 4 mm
MD508 FG	975,0	38.38	975,0	38.38	± 5 mm
MD508 FG	1050,0	41.34	1050,0	41.34	± 5 mm
MD508 FG	1125,0	44.29	1125,0	44.29	± 5 mm

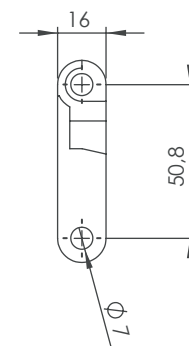
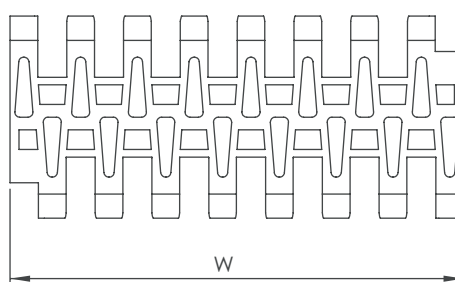

- Standard belt increments 75 mm.
- Non-standard belt increments 18,75 mm.
- Please contact with customer service for precise belt measurements.



MD508 PR%25

Modular Belt Series

• Meat Applications

Dressing Lines, Trim Lines, Elevator, Metal Detector

• Poultry Applications

Cut-up Lines, Debonning Lines, Chiller Discharge, Rehang / Bird Accumulation, Freezing Lines, Elevators

• Sea Food Applications

Draining, Elevator

• Snack Food Applications

Can Draining

• Fruits and Vegetables Applications

Prewashing / Rinsing, Draining, Peeling, Elevator, Blanching



MD508 PR%25 (Heavy Duty Food Belts)



Pitch:	50,8 mm / 2 inch
Belt Surface:	Open, Smooth Surface
Minimum Width:	150 mm / 5.90 inch
Open Area (%):	25%. (Biggest opening 3 x 19,5 mm)
Flight:	Yes (T50, T100, T150)
Sidewall:	No
Rod:	Ø7 mm / 0.275 inch - Self Lock
Approved:	FDA and EU
Curve:	No
Color:	Additional colors available
Cleanability:	Good
Belt Thickness:	16 mm / 0.629 inch

Product Features and Functional Benefits

- Belt provides optimal open area for drainage and airflow.
- Unique sprocket engagement reduces pulsation and increases load capacity.
- High power, bi-directional belt for long conveyors.
- Unique sprocket engagement - higher product load and longer conveyors.
- Strong and thick product supports allow more load without breaking.
- Impact resistance to with stand heavy objects falling on the belt.

Available Moulded Module Sizes

- 150 mm / **5.90 inch** module

MD508 PR%25 / Technical Information

BELT MATERIAL	BELT STRENGTH				TEMPERATURE		BELT WEIGHT
	Straight		Curve		°C (min.) - °F (min.)	°C (max.) - °F (max.)	Kg/m ² - lb/ft ²
	N/m	lb/ft	N/m	lb/ft			
Polypropylene	41800	2863	-	-	+5 / +42.8	+90 / +194	8,0 - 1.64
Polyethylene	26400	1808	-	-	-73 / -99.4	+66 / +150.8	8,3 - 1.70
Acetal	60500	4145	-	-	-43 / -45.4	+110 / +230	12,0 - 2.46

- Belt strength and temperature values are maximum on the table.

MD508 PR%25 / Standard Belt Widths

BELT SERIES	WIDTH (W)				Belt With Tolerance (max.)
	PP-PE		POM		
	mm	inch	mm	inch	
MD508 PR25	150,0	5.91	150,0	5.91	± 1 mm
MD508 PR25	225,0	8.86	225,0	8.86	± 2 mm
MD508 PR25	300,0	11.81	300,0	11.81	± 2 mm
MD508 PR25	375,0	14.76	375,0	14.76	± 2 mm
MD508 PR25	450,0	17.72	450,0	17.72	± 3 mm
MD508 PR25	525,0	20.67	525,0	20.67	± 3 mm
MD508 PR25	600,0	23.62	600,0	23.62	± 3 mm
MD508 PR25	675,0	26.57	675,0	26.57	± 4 mm
MD508 PR25	750,0	29.53	750,0	29.53	± 4 mm
MD508 PR25	825,0	32.48	825,0	32.48	± 4 mm
MD508 PR25	900,0	35.43	900,0	35.43	± 4 mm
MD508 PR25	975,0	38.38	975,0	38.38	± 5 mm
MD508 PR25	1050,0	41.34	1050,0	41.34	± 5 mm
MD508 PR25	1125,0	44.29	1125,0	44.29	± 5 mm

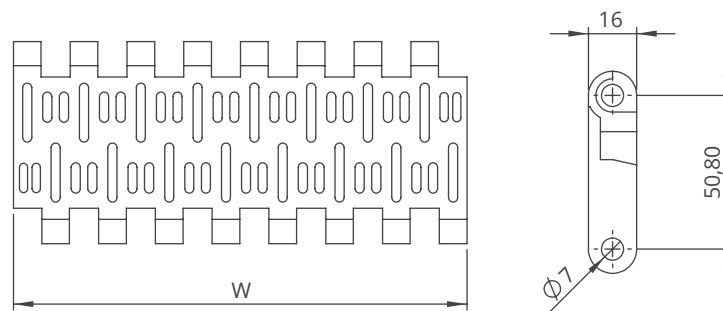

- Standard belt increments 75 mm.
- Non-standard belt increments 18,75 mm.
- Please contact with customer service for precise belt measurements.

MD508 Series Sprockets and Technical Specifications



Z8



Z10



Z12

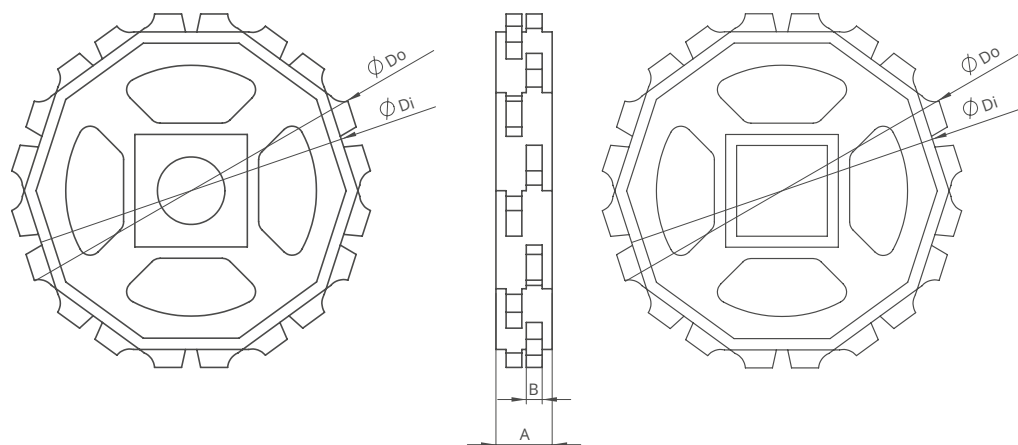

MD508 Series / Standard Sprockets Dimensions

NO. TEETH	Di mm/inch	Do mm/inch	B mm/inch	A mm/inch	Square Bore (Q) mm/inch	Round Bore (R) mm/inch	PRODUCT CODE	
							Square Type (Q)	Round Type (R)
Z8	107,37 / 4.23	127,35 / 5.01	7 / 0.27	40 / 1.57	40 / 1.5	25-30 / 1-1.25	MD508SQZ8*POM	MD508SRZ8*POM
Z10	141,27 / 5.56	160,14 / 6.30	7 / 0.27	40 / 1.57	40-60 / 1.5-2.5	25-30 / 1-1.25	MD508SQZ10*POM	MD508SRZ10*POM
Z12	174,71 / 6.87	193,24 / 7.61	7 / 0.27	40 / 1.57	40-60 / 1.5-2.5	25-30 / 1-1.25	MD508SQZ12*POM	MD508SRZ12*POM

*Other sprockets and hub sizes are manufactured up to request.

*PA (Polyamide) and PP (Polypropylene) sprockets raw material is available on request.

***Machined Split Sprockets are available for each size.**



Clamp



Machined Split Sprocket

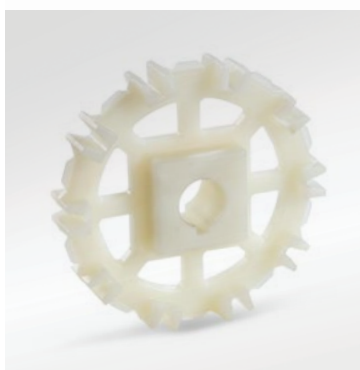

Moulded Sprocket

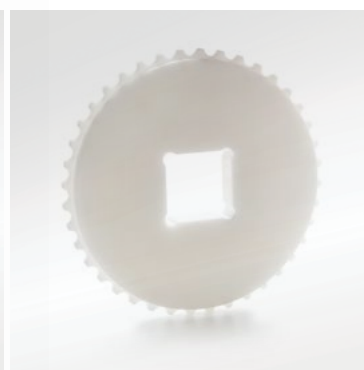

Machined Sprocket

MD508 Series *Accessories and Technical Specifications*

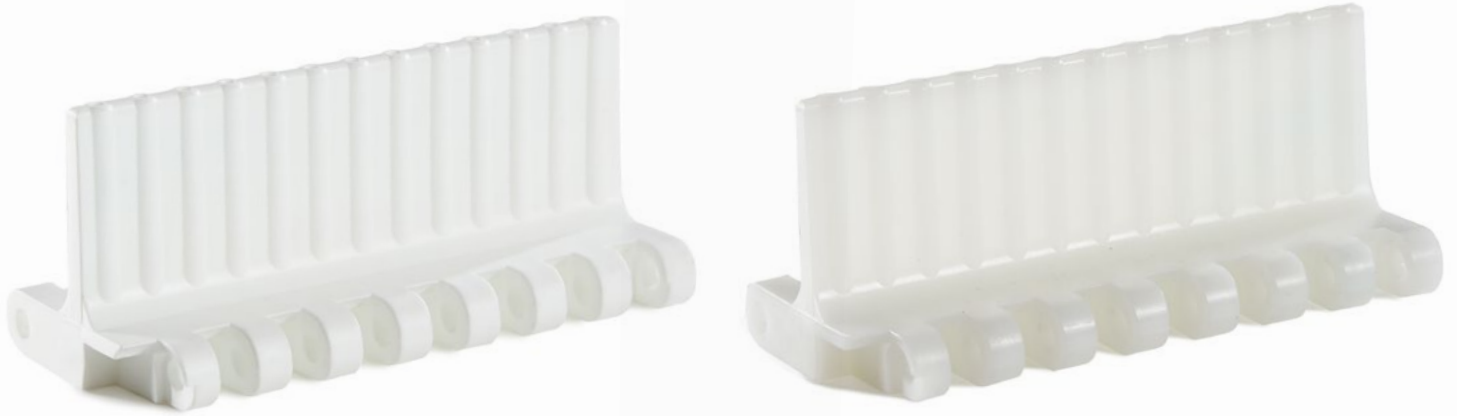

MD508 Series / Flight Dimensions

MD508 Series / Flights				
PRODUCT CODE	Flight Height (mm/ inch)	Flight Width (mm/ inch)	PRODUCT CODE	Sidewall Height (mm/ inch)
MD508T50	50 / 2	150 / 5.90	-	-
MD508T100	100 / 4	150 / 5.90	-	-
MD508T150	150 / 6	150 / 5.90	-	-

MD508 Series / Flight Technical Specifications

Possible Flight Indents for MD508 Series	Z	
	mm	inch
Standard, module cutting	37,5	1.48
Standard, module cutting	56,0	2.20
Standard, no module cutting	75,0	2.95
Standard, module cutting	112,5	4.43

*Non-standard flight indent is on request.

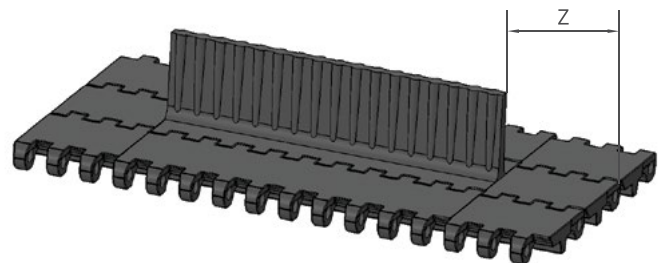

MD508 Series *Engineering Information*

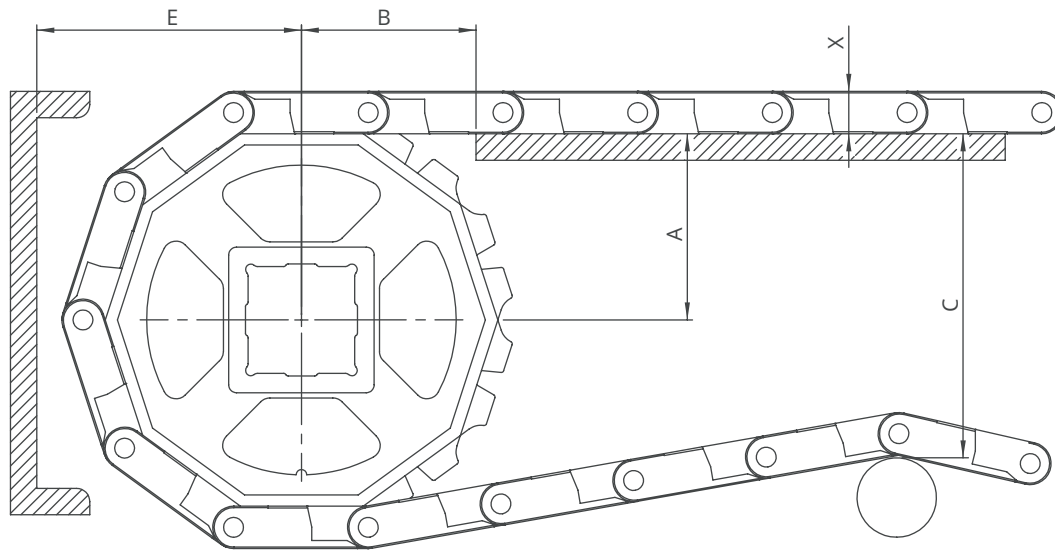

A - ± 0,031" (1mm) C - ± (Max.)
 B - ± 0,125" (3mm) E - ± (Min.)

MD508 Series / Conveyor Frame Dimensions

Sprockets Description		A		B		C		E		X		
Pitch Diameter		Range (Bottom to Top)		inch	mm	inch	mm	inch	mm	inch	mm	
inch	mm	inch	mm									
MD508 C, MD508 PR%25, MD508 FG												
4.65	118,0	8	2.29	58,1	2.94	74,8	3.79	96,2	3.11	79,1	0.63	16,0
5.94	151,0	10	2.92	74,3	3.57	90,7	5.06	128,5	3.75	95,3	0.63	16,0
7.32	186,0	12	3.56	90,5	4.20	106,7	6.33	160,9	4.39	111,4	0.63	16,0

MD508 Series / Slider Support System For Straight Running Belts

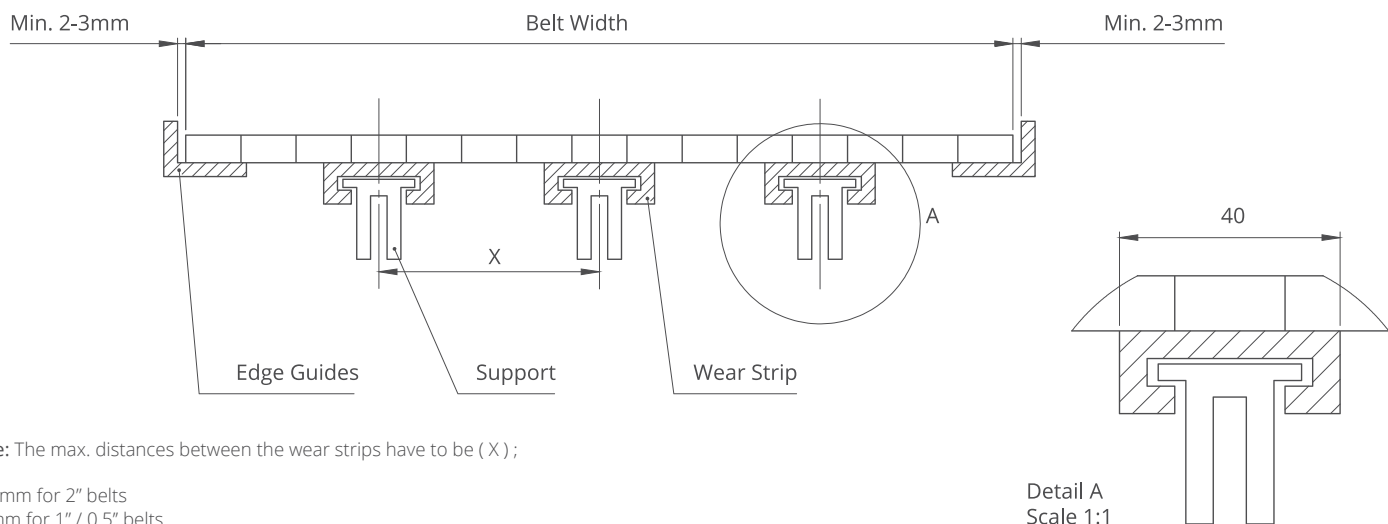

Note: The max. distances between the wear strips have to be (X) ;

125 mm for 2" belts
 80 mm for 1" / 0.5" belts

Detail A
 Scale 1:1

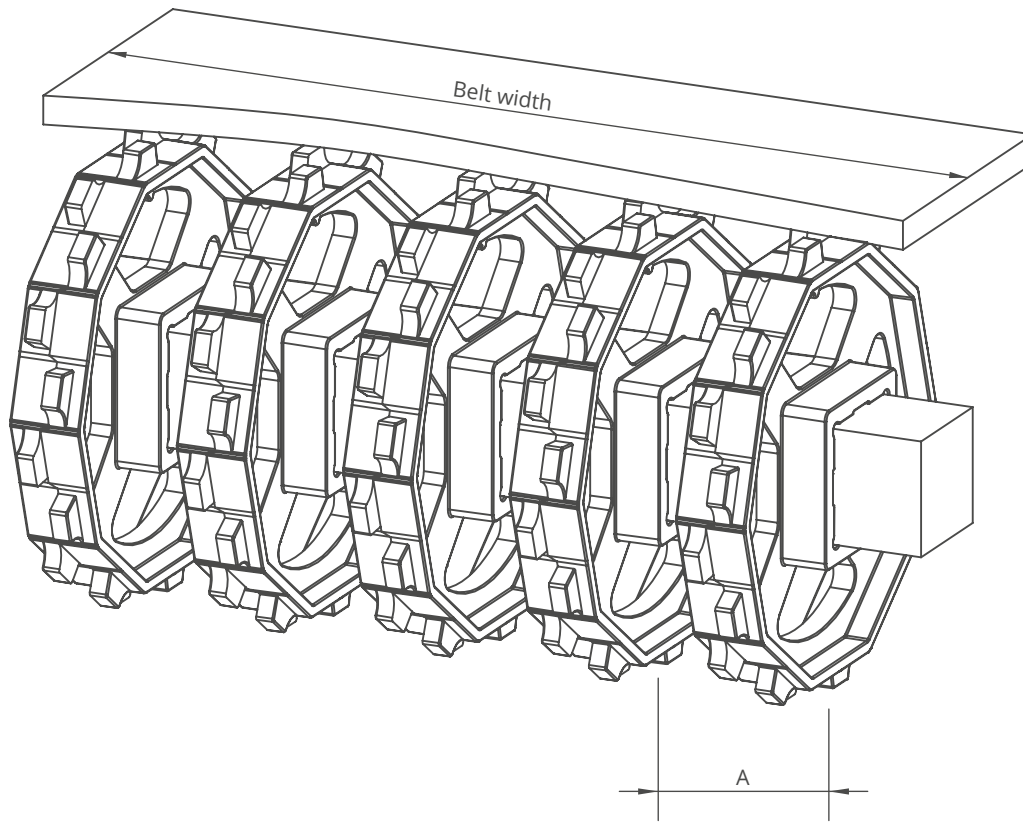

MD508 Series / Sprockets Arrangement

Standard Belt Width		Number of sprockets per shaft		A (mm/inch)	
mm	inch	Drive Shaft	Return Shaft	Min.	Max.
150,0	5.90	2	2	60/2.36	150/5.9
225,0	8.86	3	2	60/2.36	150/5.9
300,0	11.81	3	3	60/2.36	150/5.9
375,0	14.76	4	3	60/2.36	150/5.9
450,0	17.72	4	3	60/2.36	150/5.9
525,0	20.67	5	4	60/2.36	150/5.9
600,0	23.62	5	4	60/2.36	150/5.9
675,0	26.57	6	5	60/2.36	150/5.9
750,0	29.53	6	5	60/2.36	150/5.9
825,0	32.48	6	5	60/2.36	150/5.9
900,0	35.43	7	6	60/2.36	150/5.9
975,0	38.39	8	7	60/2.36	150/5.9
1050,0	41.34	9	7	60/2.36	150/5.9
1125,0	44.29	10	8	60/2.36	150/5.9
1200,0	47.24	11	8	60/2.36	150/5.9
1275,0	50.20	12	9	60/2.36	150/5.9
1350,0	53.15	13	10	60/2.36	150/5.9
1425,0	56.10	14	10	60/2.36	150/5.9
1500,0	59.06	15	11	60/2.36	150/5.9
1575,0	62.00	16	12	60/2.36	150/5.9

Note: Number of sprockets depends on the belt load.

HP508

Modular Belt Series

HP508 RR

HP508 FG

HP508 C

Sprockets & Accessories

Engineering Information





Bezelye Konservesi

İçindekiler: Bezelye, su, tuz ve asitlik düzenleyici (sitrik asit).
No: 3 Büyük Boy

Türk Gıda Kodeksi'ne uygun olarak
Gıda Sanayi A.Ş. tarafından
TICARET A.Ş. adına üretilmiştir.
Menşe Ülke: Türkiye

Bir porsiyon (130g) ürünün günlük karşılama oranları

Enerji	Şeker	Toplam Yağ	Doymuş Yağ	Tuz
118 kcal	1,1 g	0,8 g	0,0 g	1,3 g
%6	%1	%1	%0	%22

Protein	Lif
7,7 g	2,4 g
%15	%10

* Değerler 2000 kcal/gün üzerinden hesaplanmıştır.
cinsiyete, yaşa, fiziksel aktiviteye ve diğer faktörlere göre değişebilir.

Daha fazla bilgi için www.migros.com.tr
Bu ürün yaklaşık 2 porsiyondan oluşmaktadır.

Saklama Koşulları: Bombajlı ve sızınabilir kurtarılmaz alüminyum
Güneşten uzak, serin ve kokusuz yerde saklayınız.
Kapağı açıldıktan sonra buzdolabında saklayınız.

Tavsiye edilen tüketim tarihi (T.E.T.) ve
parti numarası ambalajın üzerindedir.



Bezelye Konservesi

İçindekiler: Bezelye, su, tuz ve asitlik düzenleyici (sitrik asit).
No: 3 Büyük Boy

Türk Gıda Kodeksi'ne uygun olarak
Tat Gıda Sanayi A.Ş. tarafından
MIGROS TİCARET A.Ş. adına üretilmiştir.
Menşe Ülke: Türkiye

Bir porsiyon (130g) ürünün günlük karşılama oranları

Enerji	Şeker	Toplam Yağ	Doymuş Yağ	Tuz
118 kcal	1,1 g	0,8 g	0,0 g	1,3 g
%6	%1	%1	%0	%22

* Değerler 2000 kcal/gün üzerinden hesaplanmıştır.
cinsiyete, yaşa, fiziksel aktiviteye ve diğer faktörlere göre değişebilir.

Daha fazla bilgi için www.migros.com.tr
Bu ürün yaklaşık 2 porsiyondan oluşmaktadır.

Saklama Koşulları: Bombajlı ve sızınabilir kurtarılmaz alüminyum
Güneşten uzak, serin ve kokusuz yerde saklayınız.
Kapağı açıldıktan sonra buzdolabında saklayınız.

Tavsiye edilen tüketim tarihi (T.E.T.) ve
parti numarası ambalajın üzerindedir.



Kalite ve FSSC 22000 Gıda Güvenliği
Yönetim Sistem Belgelerine sahiptir.

Gıda İşletmecisi Adı:

Gıda İşletmecisi Adresi:
Atatürk Mah. Turgut Özal Bulvarı
No: 7 Ataşehir / İSTANBUL

Müşteri Hizmetleri Hattı:
444 10 44

ÜRETİCİ FIRMA ADI:
GIDA SANAYİ A.Ş.

ÜRETİCİ FIRMA ADRESİ:
Vehbi Koç Cad. Tatkavaklı Kasabası
Mustafakemalpaşa-Bursa

İşletme kayıt no: TR-16-K-000470



Net Ağırlık:
830g e





HP508 RR

Modular Belt Series

• **Snack Foods Applications**

Cooling Line

• **Fruits and Vegetables Applications**

Palletizing - Epalletizing, Sterilization Conveyance

• **Automotive Applications**

Battery Filling

• **Tire Manufacturing Applications**

Dip Tank

• **Packaging Applications**

Accumulation, Palletizing - Depalletizing

• **Textile Applications**

Dyeing

• **Beverages and Bottling Applications**

Glass Palletizing - Depalletizing, Pasteurizers - Warmers, Accumulation Tables

• **Can Manufacturing Applications**

Accumulation Tables, Palletizing / Depalletizing



HP508 RR

Pitch:	50,8 mm / 2 inch
Belt Surface:	Open, Raised Rib Surface
Minimum Width:	152,4 mm / 6 inch
Open Area (%):	36%. (Biggest opening 3,5 x 18,5 mm)
Flight:	No
Sidewall:	No
Rod:	Ø7 mm / 0.275 inch - Self Lock
Approved:	FDA and EU
Curve:	No
Color:	Additional colors available
Cleanability:	Good
Belt Thickness:	24 mm / 0.945 inch
Comb:	Yes



Product Features and Functional Benefits

- Less friction and product contact for easy cooking, cooling and freezing of products.
- Reduces back line pressure with up to 70%.
- Reduced dirt and oxide build up due to self cleaning surface.
- Finger plate for trouble free transfer.
- Unique sprocket engagement reduces pulsation and increases load capacity.

Available Moulded Module Sizes

- 152,4 mm / **6 inch** module
- 76,2 mm / **3 inch** module

HP508 RR / Technical Information

BELT MATERIAL	BELT STRENGTH				TEMPERATURE		BELT WEIGHT
	Straight		Curve		°C (min.) - °F (min.)	°C (max.) - °F (max.)	
	N/m	lb/ft	N/m	lb/ft			Kg/m ² - lb/ft ²
Polypropylene	34200	2343	-	-	+5 / +42.8	+90 / +194	8,9 - 1.82
PPHomopolymer	34200	2343	-	-	+5 / +42.8	+118 / +244	8,9 - 1.82
Acetal	45500	3117	-	-	-43 / -45.4	+110 / +230	13,5 - 2.76

- Belt strength and temperature values are maximum on the table.

HP508 RR / Standard Belt Widths

BELT SERIES	WIDTH (W)				Belt With Tolerance (max.)
	PP-PPH		POM		
	mm	inch	mm	inch	
HP508 RR	152,4	6.0	152,4	6.0	± 0,5 mm
HP508 RR	228,6	9.0	228,6	9.0	± 2 mm
HP508 RR	304,8	12.0	304,8	12.0	± 2 mm
HP508 RR	381,0	15.0	381,0	15.0	± 2 mm
HP508 RR	457,2	18.0	457,2	18.0	± 3 mm
HP508 RR	533,4	21.0	533,4	21.0	± 3 mm
HP508 RR	609,6	24.0	609,6	24.0	± 3 mm
HP508 RR	685,8	27.0	685,8	27.0	± 3 mm
HP508 RR	762,0	30.0	762,0	30.0	± 4 mm
HP508 RR	838,2	33.0	838,2	33.0	± 4 mm
HP508 RR	914,4	36.0	914,4	36.0	± 4 mm
HP508 RR	990,6	39.0	990,6	39.0	± 5 mm
HP508 RR	1066,8	42.0	1066,8	42.0	± 5 mm
HP508 RR	1143,0	45.0	1143,0	45.0	± 5 mm

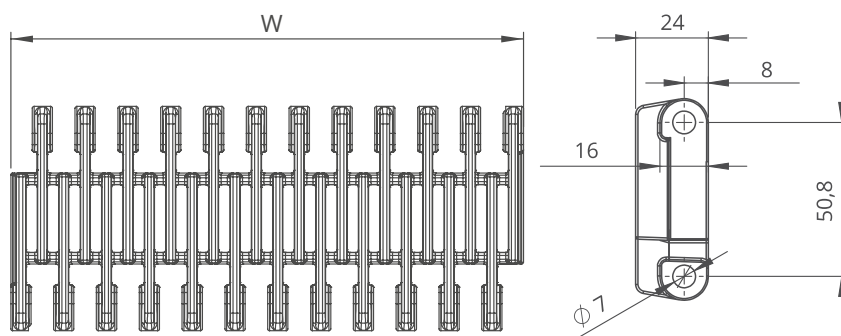

- Standard belt increments 76,2 mm.
- Non-standart belt increments 38,1 mm.
- Please contact with customer service for precise belt measurements.



HP508 FG

Modular Belt Series

- **Snack Foods Applications**

Cooling Line

- **Fruits and Vegetables Applications**

Palletizing - Epalletizing, Sterilization Conveyance

- **Automotive Applications**

Battery Filling

- **Tire Manufacturing Applications**

Dip Tank

- **Packaging Applications**

Accumulation, Palletizing - Depalletizing

- **Textile Applications**

Dyeing

- **Beverages and Bottling Applications**

Glass Palletizing - Depalletizing, Pasteurizers - Warmers, Accumulation Tables

- **Can Manufacturing Applications**

Accumulation Tables, Palletizing / Depalletizing



HP508 FG (Battery Belt)

Pitch:	50,8 mm / 2 inch
Belt Surface:	Open, Smooth Surface
Minimum Width:	152,4 mm / 6 inch
Open Area (%):	36%. (Biggest opening 3,5 x 18,5 mm)
Flight:	No
Sidewall:	No
Rod:	Ø7 mm / 0.276 inch - Self Lock
Approved:	FDA and EU
Curve:	No
Color:	Additional colors available
Cleanability:	Good
Belt Thickness:	16 mm / 0.630 inch



Product Features and Functional Benefits

- Belt provides optimal open area for drainage and airflow.
- Unique sprocket engagement reduces pulsation and increases load capacity.
- High power, bi-directional belt for long conveyors.
- Unique sprocket engagement - higher product load and longer conveyors.
- Strong and thick product supports allow more load without breaking.
- Impact resistance to with stand heavy objects falling on the belt.

Available Moulded Module Sizes

- 152,4 mm / **6 inch** module
- 76,2 mm / **3 inch** module

HP508 FG / Technical Information

BELT MATERIAL	BELT STRENGTH				TEMPERATURE		BELT WEIGHT
	Straight		Curve		°C (min.) - °F (min.)	°C (max.) - °F (max.)	Kg/m ² - lb/ft ²
	N/m	lb/ft	N/m	lb/ft			
Polypropylene	34200	2343	-	-	+5 / +42.8	+90 / +194	8,9 - 1.82
Polyethylene	-	-	-	-	-	-	-
Acetal	-	-	-	-	-	-	-

- Belt strength and temperature values are maximum on the table.

HP508 FG / Standard Belt Widths

BELT SERIES	WIDTH (W)				Belt With Tolerance (max.)
	PP		POM		
	mm	inch	mm	inch	
HP508 FG	152,4	6.0	-	-	± 0,5 mm
HP508 FG	228,6	9.0	-	-	± 2 mm
HP508 FG	304,8	12.0	-	-	± 2 mm
HP508 FG	381,0	15.0	-	-	± 2 mm
HP508 FG	457,2	18.0	-	-	± 3 mm
HP508 FG	533,4	21.0	-	-	± 3 mm
HP508 FG	609,6	24.0	-	-	± 3 mm
HP508 FG	685,8	27.0	-	-	± 3 mm
HP508 FG	762,0	30.0	-	-	± 4 mm
HP508 FG	838,2	33.0	-	-	± 4 mm
HP508 FG	914,4	36.0	-	-	± 4 mm
HP508 FG	990,6	39.0	-	-	± 5 mm
HP508 FG	1066,8	42.0	-	-	± 5 mm
HP508 FG	1143,0	45.0	-	-	± 5 mm

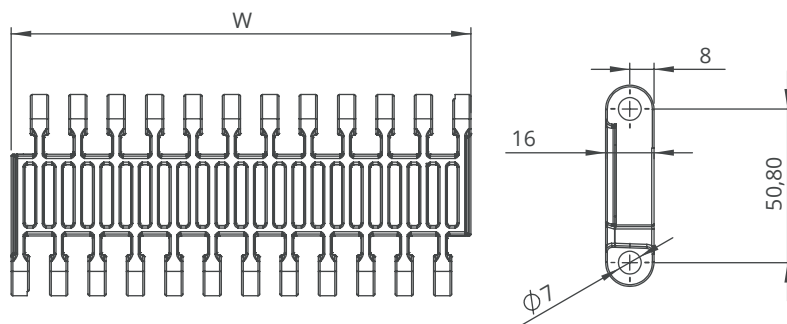

- Standard belt increments 76,2 mm.
- Non-standart belt increments 38,1 mm.
- Please contact with customer service for precise belt measurements.



HP508 C

Modular Belt Series

- ***Snack Food Applications***

Potato Processing

- ***Fruits and Vegetables Applications***

Bulk Feeding, Elevator, Control Sorting Table, Filling

- ***Automotive Applications***

Chair Lift - Feeder

- ***Packaging Applications***

Bluk Inclines, Box Transport Horizontal



HP508 C

Pitch:	50,8 mm / 2 inch
Belt Surface:	Close, Smooth Surface
Minimum Width:	152,4 mm / 6 inch
Open Area (%):	0%
Flight:	No
Sidewall:	No
Rod:	Ø7 mm / 0.275 inch - Self Lock
Approved:	FDA and EU
Curve:	No
Color:	Additional colors available
Cleanability:	Good
Belt Thickness:	16 mm / 0.629 inch



Product Features and Functional Benefits

- Unique sprocket engagement reduces pulsation and increases load capacity.
- High power, bi-directional belt for long conveyors.
- Unique sprocket engagement - higher product load and longer conveyors.
- Strong and thick product supports allow more load without breaking.
- Impact resistance to withstand heavy objects falling into the belt.
- Close transfer applications.

Available Moulded Module Sizes

- 152,4 mm / **6 inch** module
- 76,2 mm / **3 inch** module

HP508 C / Technical Information

BELT MATERIAL	BELT STRENGTH				TEMPERATURE		BELT WEIGHT
	Straight		Curve		°C (min.) - °F (min.)	°C (max.) - °F (max.)	Kg/m ² - lb/ft ²
	N/m	lb/ft	N/m	lb/ft			
Polypropylene	34200	2343	-	-	+5 / +42.8	+90 / +194	7,8 - 1.60
Polyethylene	-	-	-	-	-	-	-
Acetal	45500	3117	-	-	-43 / -45.4	+110 / +230	12,2 - 2.50

- Belt strength and temperature values are maximum on the table.

HP508 C / Standard Belt Widths

BELT SERIES	WIDTH (W)				Belt With Tolerance (max.)
	PP		POM		
	mm	inch	mm	inch	
HP508 C	152,4	6.0	152,4	6.0	± 0,5 mm
HP508 C	228,6	9.0	228,6	9.0	± 2 mm
HP508 C	304,8	12.0	304,8	12.0	± 2 mm
HP508 C	381,0	15.0	381,0	15.0	± 2 mm
HP508 C	457,2	18.0	457,2	18.0	± 3 mm
HP508 C	533,4	21.0	533,4	21.0	± 3 mm
HP508 C	609,6	24.0	609,6	24.0	± 3 mm
HP508 C	685,8	27.0	685,8	27.0	± 3 mm
HP508 C	762,0	30.0	762,0	30.0	± 4 mm
HP508 C	838,2	33.0	838,2	33.0	± 4 mm
HP508 C	914,4	36.0	914,4	36.0	± 4 mm
HP508 C	990,6	39.0	990,6	39.0	± 5 mm
HP508 C	1066,8	42.0	1066,8	42.0	± 5 mm
HP508 C	1143,0	45.0	1143,0	45.0	± 5 mm

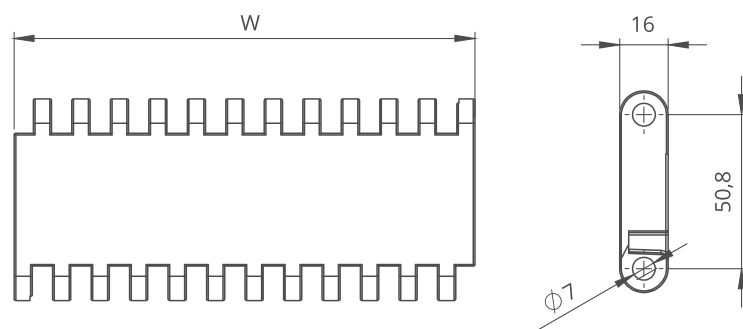

- Standard belt increments 76,2 mm.
- Non-standart belt increments 38,1 mm.
- Please contact with customer service for precise belt measurements.

HP508 Series Sprockets and Technical Specifications



Z8

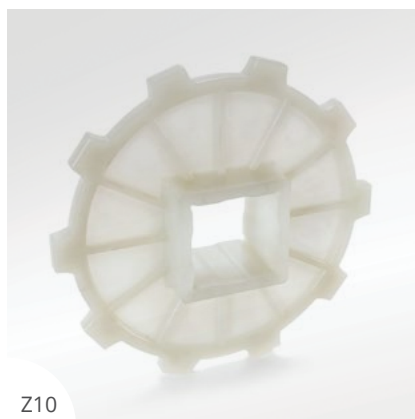

Z10

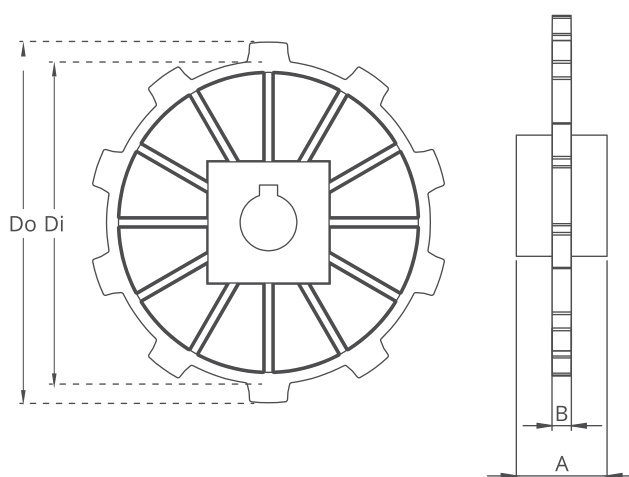
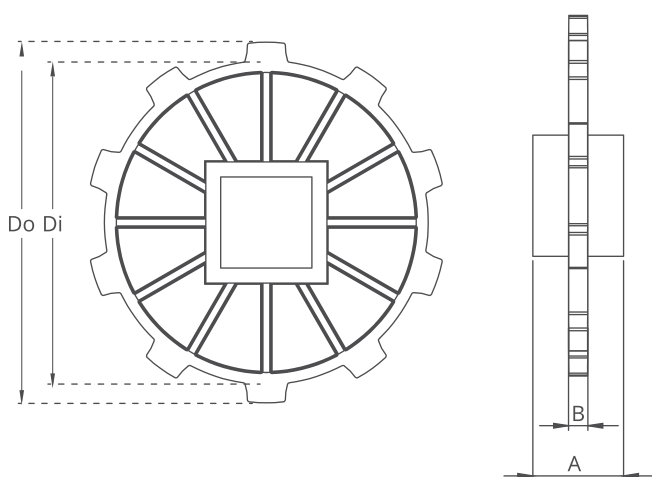

HP508 Series / Standard Sprockets Dimensions

NO. TEETH	Di mm/inch	Do mm/inch	B mm/inch	A mm/inch	Square Bore (Q) mm/inch	Round Bore (R) mm/inch	PRODUCT CODE	
							Square Type (Q)	Round Type (R)
Z8	109,0 / 4.29	125,0 / 4.92	9,0 / 0.35	40 / 1.57	40 / 1.5	25-30 / 1-1.25	HP508SQZ8*PA	HP508SRZ8*PA
Z10	142,0 / 5.59	159,0 / 6.22	9,0 / 0.35	40 / 1.57	40 / 1.5	25-30 / 1-1.25	HP508SQZ10*PA	HP508SRZ10*PA

*Other sprockets and hub sizes are manufactured up to request.

*POM (Acetal) and PP (Polypropylene) sprockets raw material is available on request.

***Machined Split Sprockets are available for each size.**



Clamp



Machined Split Sprocket

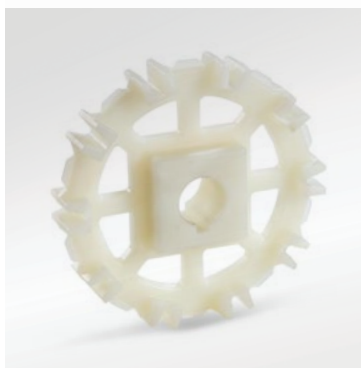

Moulded Sprocket

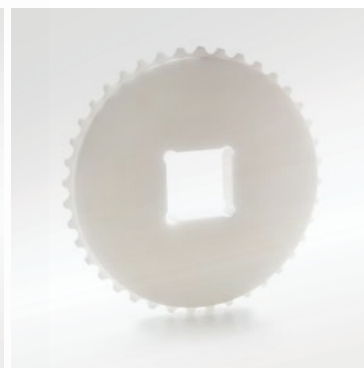

Machined Sprocket

HP508 Series *Accessories and Technical Specifications*



MODUTECH

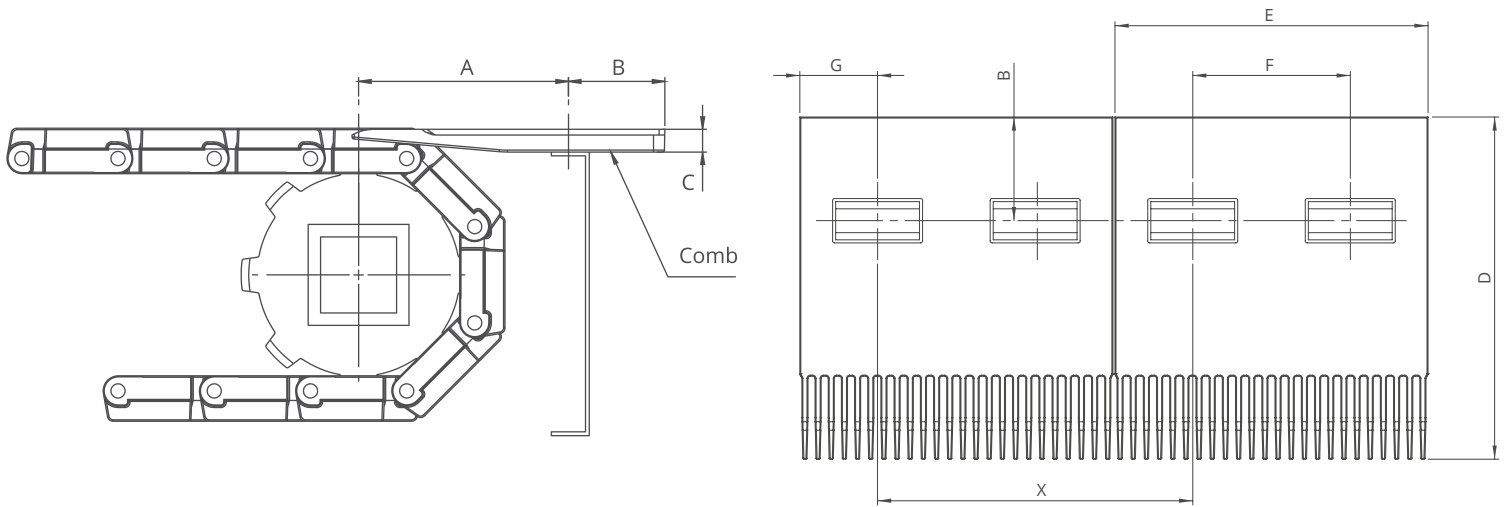
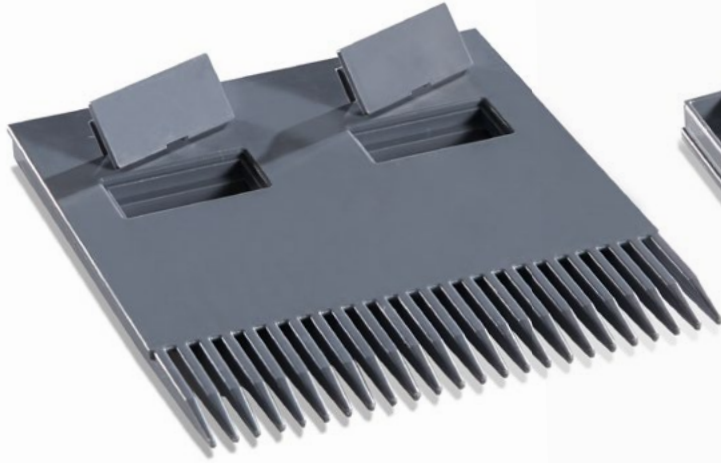

HP508 Series / Comb Technical Specifications

	inch	mm
A	3.94	100,0
B	1.97	50,0
C	0.47	12,0
D	6.50	165,0
E	5.94	151,0
F	2.99	76,0
G	1.48	37,5
X	5.98	152,0

HP508 Series *Engineering Information*

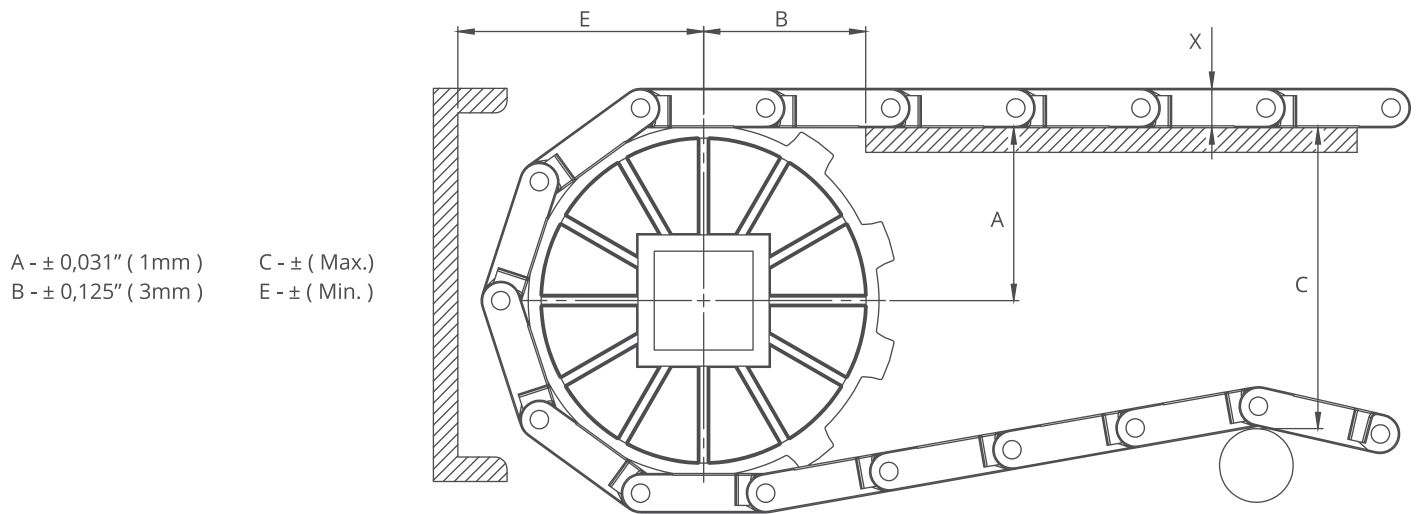

A - $\pm 0,031''$ (1mm)
 B - $\pm 0,125''$ (3mm)
 C - \pm (Max.)
 E - \pm (Min.)

HP508 Series / Conveyor Frame Dimensions

Sprockets Description			A		B		C		E		X	
Pitch Diameter		No.Teeth	Range (Bottom to Top)		inch	mm	inch	mm	inch	mm	inch	mm
inch	mm		inch	mm								
HP508 C, HP508 FG												
4.57	116,0	8	2.29	58,25	2.28	58,0	3.46	88,0	3.32	84,25	0.63	16,0
5.98	152,0	10	2.93	74,5	2.60	66,0	4.80	122,0	3.96	100,5	0.63	16,0
HP508 RR												
4.57	116,0	8	2.29	58,25	2.28	58,0	3.78	96,0	3.63	92,25	0.94	24,0
5.98	152,0	10	2.93	74,5	2.60	66,0	5.12	130,0	4.27	108,5	0.94	24,0

HP508 Series / Slider Support System For Straight Running Belts

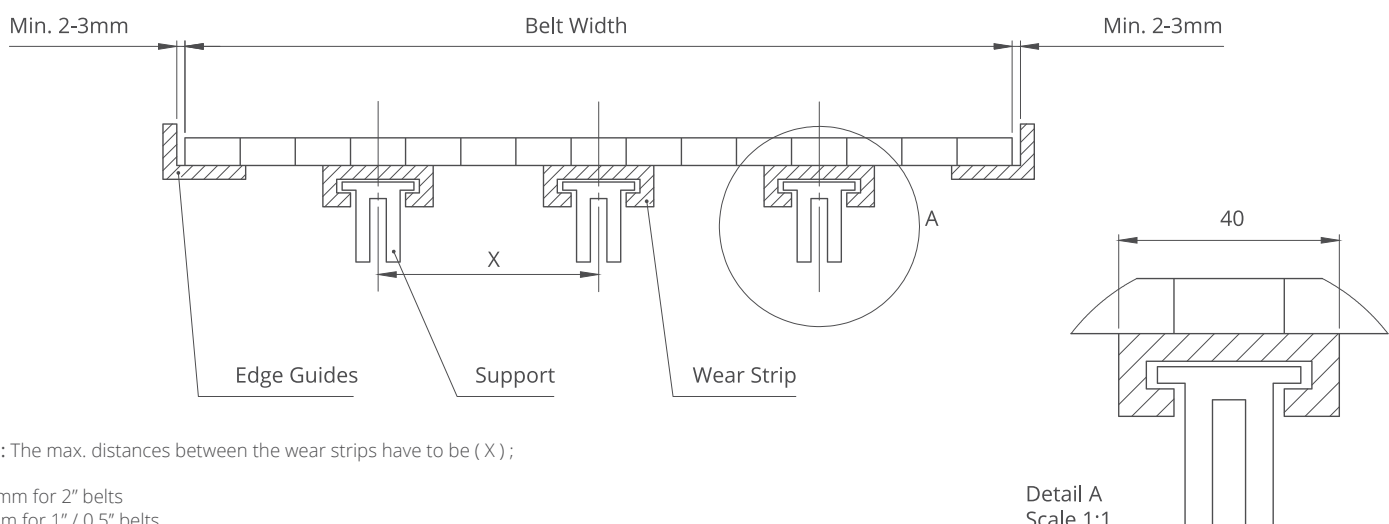

Note: The max. distances between the wear strips have to be (X) ;

125 mm for 2" belts
 80 mm for 1" / 0.5" belts

Detail A
 Scale 1:1

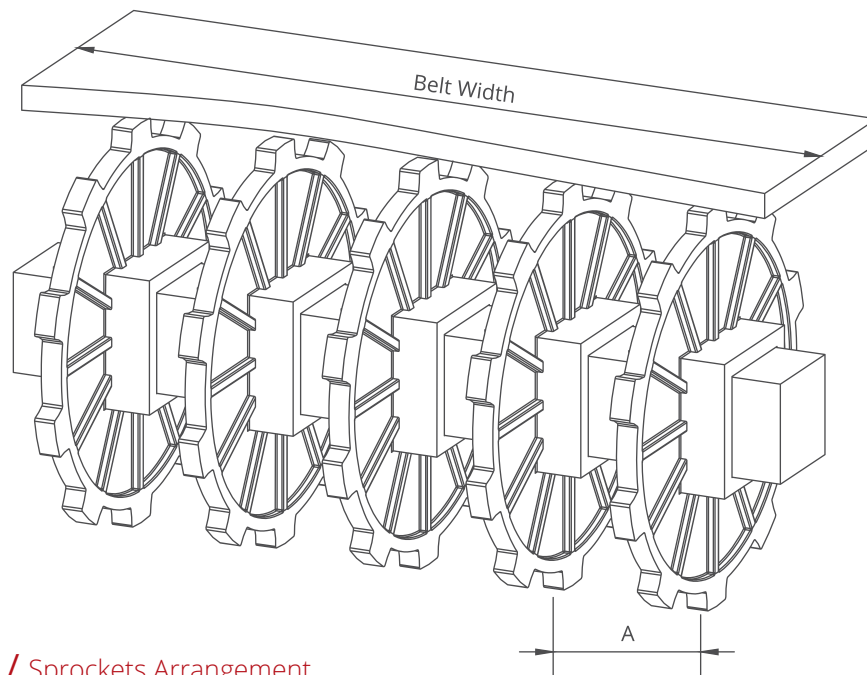

HP508 Series / Sprockets Arrangement

Standard Belt Width		Number of sprockets per shaft		A (mm/inch)	
mm	inch	Drive Shaft	Return Shaft	Min.	Max.
152,4	6.0	2	2	60/2.36	150/5.9
228,6	9.0	2	2	60/2.36	150/5.9
304,8	12.0	3	2	60/2.36	150/5.9
381,0	15.0	3	3	60/2.36	150/5.9
457,2	18.0	3	3	60/2.36	150/5.9
533,4	21.0	4	3	60/2.36	150/5.9
609,6	24.0	4	3	60/2.36	150/5.9
685,8	27.0	5	3	60/2.36	150/5.9
762,0	30.0	5	4	60/2.36	150/5.9
838,2	33.0	6	4	60/2.36	150/5.9
914,4	36.0	6	4	60/2.36	150/5.9
990,6	39.0	6	4	60/2.36	150/5.9
1066,8	42.0	7	5	60/2.36	150/5.9
1143,0	45.0	7	5	60/2.36	150/5.9
1219,2	48.0	8	6	60/2.36	150/5.9
1295,4	51.0	8	6	60/2.36	150/5.9
1371,6	54.0	9	6	60/2.36	150/5.9
1447,8	57.0	9	7	60/2.36	150/5.9
1524,0	60.0	9	7	60/2.36	150/5.9
1600,2	63.0	10	7	60/2.36	150/5.9
1676,4	66.0	10	8	60/2.36	150/5.9
1752,6	69.0	11	8	60/2.36	150/5.9
1828,8	72.0	12	9	60/2.36	150/5.9
1905,0	75.0	12	9	60/2.36	150/5.9
1981,2	78.0	12	9	60/2.36	150/5.9
2057,4	81.0	13	10	60/2.36	150/5.9
2133,6	84.0	14	10	60/2.36	150/5.9
2209,8	87.0	14	10	60/2.36	150/5.9
2286,0	90.0	15	11	60/2.36	150/5.9
2514,6	99.0	15	11	60/2.36	150/5.9
2743,2	108.0	16	12	60/2.36	150/5.9
2971,8	117.0	17	13	60/2.36	150/5.9
3200,4	126.0	18	14	60/2.36	150/5.9
3429,0	135.0	19	15	60/2.36	150/5.9
3657,6	144.0	20	16	60/2.36	150/5.9
3810,0	150.0	21	17	60/2.36	150/5.9

Note: Number of sprockets depends on the belt load.

Radius Belts

Modular Belt Series

EC254 R

EC254 R-GT / Friction Top

EC254T R

Sprockets & Accessories

Engineering Information

Radius Belt Calculation







EC254 R

Modular Radius Belt Series

- **Meat Applications**

Spiral Freezer

- **Poultry Applications**

Spiral Freezer

- **Seafood Applications**

Freezing Lines, Spiral

- **Bakery Applications**

Spiral, Proofing, Cooling, Freezing Lines, Pan Handling

- **Fruits and Vegetables Applications**

Container Conveyence

- **Automotive Applications**

Car Part Manufacturing, Battery Filling

- **Packaging Applications**

Tray Packers, Box Transport Horizontal



EC254 R

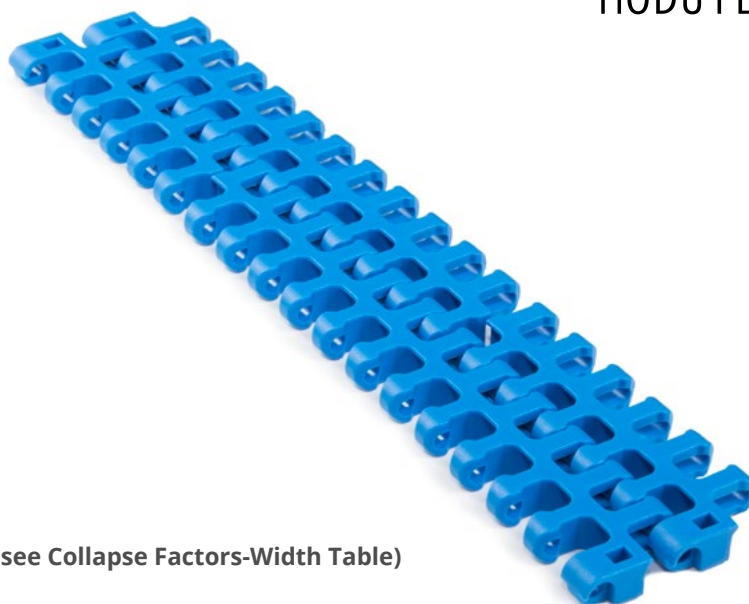

Pitch :	25,8 mm / 1 inch
Belt Surface :	Open, Smooth Surface
Minimum Width :	100 mm / 3.94 inch
Open Area (%) :	36%. (Biggest opening 7,5 x 12 mm)
Flight :	Yes. (T25, T50)
Side Wall :	Yes. (h=25 mm)
Rod :	Ø5 mm / 0.197 inch - Self Lock
Approved :	FDA and EU
Curve :	Yes
Color :	Additional colors available
Cleanability :	Excellent
Application :	Straight and side flexing
Collapse Factor :	2.1 - 2.4 (Please check page 157 to see Collapse Factors-Width Table)
Belt Thickness:	11 mm / 0.433 inch

Product Features and Functional Benefits

- Available for light and medium load capacity.
- 180 degree high speed side flexing applications.
- High temperature and wear resistance.
- Unique locking system.
- Belt provides optimal open area for drainage and airflow.

Available Moulded Module Sizes

- 200 mm / **7.87 inch** module
- 100 mm / **3.94 inch** module

EC254 R / Technical Information

BELT MATERIAL	BELT STRENGTH				TEMPERATURE		BELT WEIGHT
	Straight		Curve		°C (min.) - °F (min.)	°C (max.) - °F (max.)	Kg/m ² - lb/ft ²
	N/m	lb/ft	N/m	lb/ft			
Polypropylene	20900	1430	1100	248	+5 / +42.8	+90 / +194	4,7 - 0.96
Polyethylene	-	-	-	-	-	-	-
Acetal	29700	2035	1650	372	-43 / -45.4	+110 / +230	7,0 - 1.44

- Belt strength and temperature values are maximum on the table.

EC254 R / Standard Belt Widths

BELT SERIES	WIDTH (W)				Belt With Tolerance (max.)
	PP		POM		
	mm	inch	mm	inch	
EC254 R	100,0	4.0	100,0	4.0	± 0,5 mm
EC254 R	150,0	6.0	150,0	6.0	± 0,5 mm
EC254 R	200,0	8.0	200,0	8.0	± 2 mm
EC254 R	250,0	10.0	250,0	10.0	± 2 mm
EC254 R	300,0	12.0	300,0	12.0	± 3 mm
EC254 R	350,0	14.0	350,0	14.0	± 3 mm
EC254 R	400,0	16.0	400,0	16.0	± 3 mm
EC254 R	450,0	18.0	450,0	18.0	± 3 mm
EC254 R	500,0	20.0	500,0	20.0	± 4 mm
EC254 R	550,0	22.0	550,0	22.0	± 4 mm
EC254 R	600,0	24.0	600,0	24.0	± 4 mm
EC254 R	650,0	26.0	650,0	26.0	± 4 mm
EC254 R	700,0	28.0	700,0	28.0	± 4 mm
EC254 R	750,0	30.0	750,0	30.0	± 4 mm
EC254 R	800,0	32.0	800,0	32.0	± 4 mm

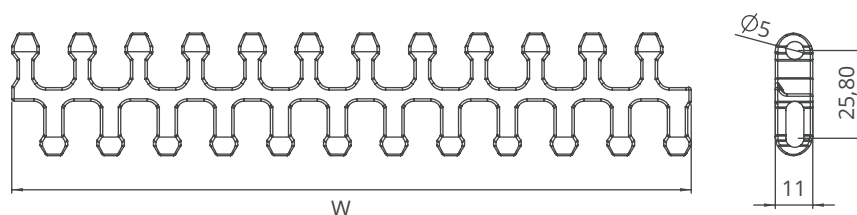

- Standard belt increments 50 mm.
- Non-standard increments 16,6 mm
- Please contact with customer service for precise belt measurements.
- For bigger sizes, please contact with customer service.



EC254 R-GT

Modular Radius Belt Series

- Meat Applications***

Spiral Freezer

- Poultry Applications***

Spiral Freezer

- Seafood Applications***

Freezing Lines, Spiral

- Bakery Applications***

Spiral, Proofing, Cooling, Freezing Lines, Pan Handling

- Fruits and Vegetables Applications***

Container Conveyence

- Automotive Applications***

Car Part Manufacturing, Battery Filling

- Packaging Applications***

Tray Packers, Box Transport Horizontal



EC254 R-GT

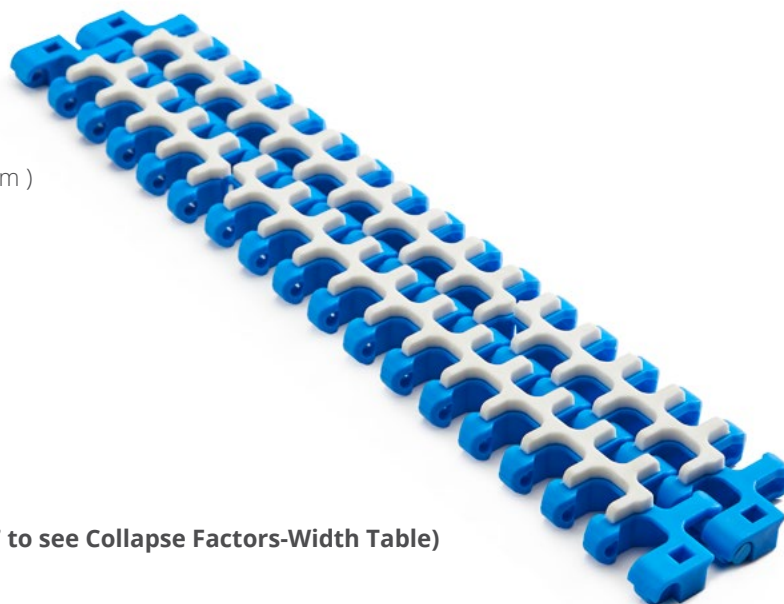

Pitch :	25,8 mm / 1 inch
Belt Surface :	Open, Friction Top Surface
Minimum Width :	100 mm / 3.94 inch
Open Area (%) :	36%. (Biggest opening 7.5 x 12 mm)
Flight :	Yes. (h=25 mm, h=50 mm)
Side Wall :	Yes. (h=25 mm)
Rod :	Ø5 mm / 0.197 inch - Self Lock
Approved :	FDA and EU
Curve :	Yes
Color :	Additional colors available
Cleanability :	Excellent
Application :	Straight and side flexing
Collapse Factor :	2.1 - 2.4 (Please check page 157 to see Collapse Factors-Width Table)
Belt Thickness:	15,5 mm / 0.61 inch

Product Features and Functional Benefits

- Available for light and medium load capacity.
- 180 degree high speed side flexing applications.
- High temperature and wear resistance.
- Unique locking system.
- Belt provides optimal open area for drainage and airflow.

Available Moulded Module Sizes

- 200 mm / **7.87 inch** edge module with 21 mm indent

EC254 R-GT / Technical Information

BELT MATERIAL	BELT STRENGTH				TEMPERATURE		BELT WEIGHT
	Straight		Curve		°C (min.) - °F (min.)	°C (max.) - °F (max.)	Kg/m ² - lb/ft ²
	N/m	lb/ft	N/m	lb/ft			
Polypropylene	20900	1430	1100	248	+5 / +42.8	+90 / +194	6,4 - 1.31
Polyethylene	-	-	-	-	-	-	-
Acetal	-	-	-	-	-	-	-

- Belt strength and temperature values are maximum on the table.

EC254 R-GT / Standard Belt Widths

BELT SERIES	WIDTH (W)				Belt With Tolerance (max.)
	PP		POM		
	mm	inch	mm	inch	
EC254 R-GT	100,0	4.0	-	-	± 0,5 mm
EC254 R-GT	150,0	6.0	-	-	± 0,5 mm
EC254 R-GT	200,0	8.0	-	-	± 2 mm
EC254 R-GT	250,0	10.0	-	-	± 2 mm
EC254 R-GT	300,0	12.0	-	-	± 3 mm
EC254 R-GT	350,0	14.0	-	-	± 3 mm
EC254 R-GT	400,0	16.0	-	-	± 3 mm
EC254 R-GT	450,0	18.0	-	-	± 3 mm
EC254 R-GT	500,0	20.0	-	-	± 4 mm
EC254 R-GT	550,0	22.0	-	-	± 4 mm
EC254 R-GT	600,0	24.0	-	-	± 4 mm
EC254 R-GT	650,0	26.0	-	-	± 4 mm
EC254 R-GT	700,0	28.0	-	-	± 4 mm
EC254 R-GT	750,0	30.0	-	-	± 4 mm
EC254 R-GT	800,0	32.0	-	-	± 4 mm

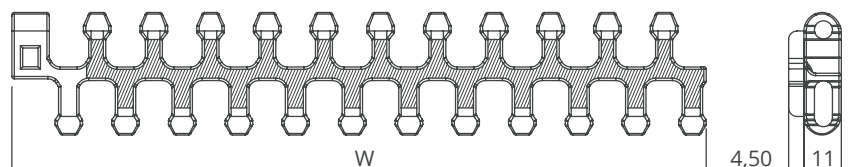

- Standard belt increments 50 mm.
- Non-standard increments 16,6 mm
- Please contact with customer service for precise belt measurements.
- For bigger sizes, please contact with customer service.

EC254 R Series Sprockets and Technical Specifications



Z15



Z8

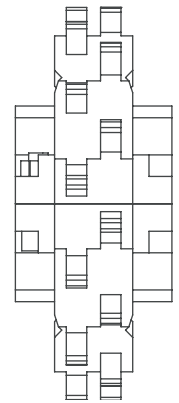
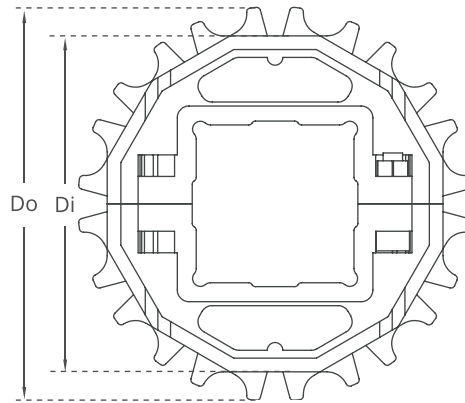
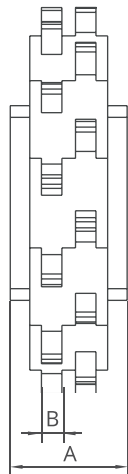
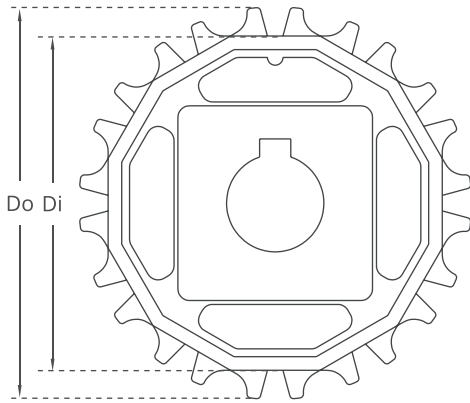

Split moulded sprockets are available.

EC254 R Series / Standard Sprockets Dimensions

NO. TEETH	Di mm/inch	Do mm/inch	B mm/inch	A mm/inch	Square Bore (Q) mm/inch	Round Bore (R) mm/inch	PRODUCT CODE	
							Square Type (Q)	Round Type (R)
Z8	52,0 / 2.05	67,0 / 2.64	6 / 0.24	30 / 1.18	25 / 1	25 / 1	MD-TR254SQ25Z8*POM	MD-TR254SRZ8*POM
Z10	69,0 / 2.72	84,0 / 3.31	6 / 0.24	30 / 1.18	40 / 1.5	25-30 / 1-1.25	MD-TR254SQZ10*POM	MD-TR254SRZ10*POM
Z12	85,84 / 3.38	100,84 / 3.97	6 / 0.24	30 / 1.18	40 / 1.5	25-30 / 1-1.25	MD-TR254SQZ12*POM	MD-TR254SRZ12*POM
Z15	110,8 / 4.36	125,8 / 4.95	6 / 0.24	30 / 1.18	40 / 1.5	25-30 / 1-1.25	MD-TR254SQZ15*POM	MD-TR254SRZ15*POM
Z16	119,1 / 4.69	134,1 / 5.28	6 / 0.24	30 / 1.18	40 / 1.5	25-30 / 1-1.25	MD-TR254SQZ16*POM	MD-TR254SRZ16*POM
Z18	135,63 / 5.34	150,58 / 5.93	6 / 0.24	30 / 1.18	40 / 1.5	25-30 / 1-1.25	MD-TR254SQZ18*POM	MD-TR254SRZ18*POM

*Other sprockets and hub sizes are manufactured up to request. *PA (Polyamide) and PP (Polypropylene) sprockets raw material is available on request.

***Machined Split Sprockets are available for each size.**



Clamp



Machined Split Sprocket

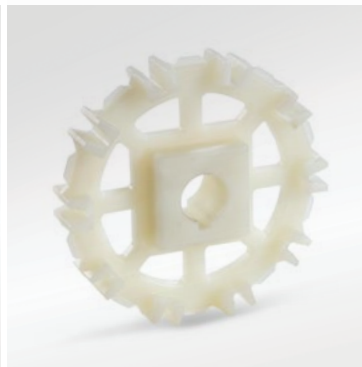

Moulded Sprocket

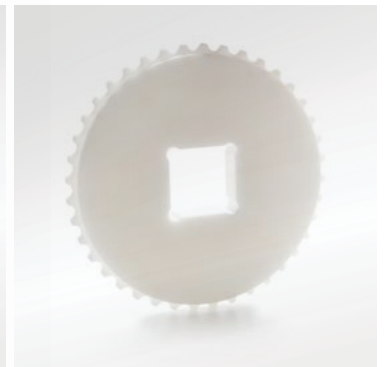

Machined Sprocket

EC254 R Series *Accessories and Technical Specifications*



MODUTECH

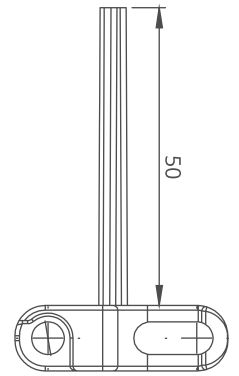
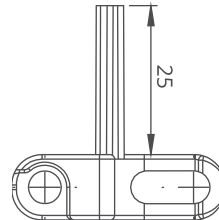

EC254 R Series / TAB - Technical Specification

TAB-M

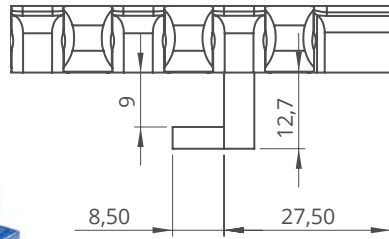

TAB-E

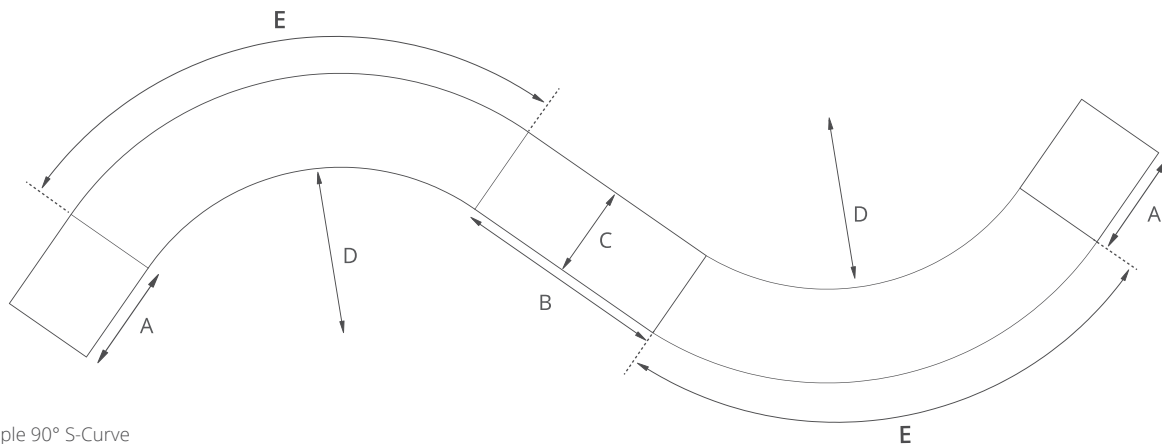
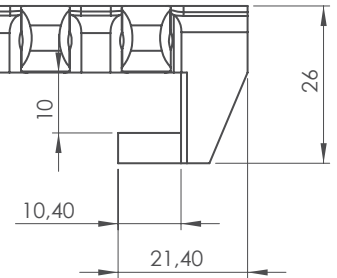

Radius Belt Example 90° S-Curve

EC254 R Series / Radius Belt Calculation

- A: Straight run pull and n = Belt width
- B: Straight run between 2 curves = min. 2 x belt width
- C: Belt width
- D: Minimum inner radius
- E: Curve length

$$\text{Collapse Factor} = \frac{\text{Min. inner radius}}{\text{Belt width}}$$

$$\text{Minimum inner radius} = \text{Collapse Factor} \times \text{Belt width}$$

CALCULATION EXAMPLE

Belt width: 400 mm 90° Radius Belt
Collapse Factor: 2.14

$$D: 400 \times 2.14 = 856 \text{ mm}$$

$$A: 400 \text{ (Min.)}$$

$$B: 2 \times 400 = 800 \text{ mm (Min.)}$$

$$E: \frac{2 \times (C+D) \times 3.14}{4} = 1972 \text{ mm}$$

$$\text{Total length} = (2 \times A) + B + (2 \times E)$$

EC254 R Series *Engineering Information*

A - ± 0,031" (1mm) C - ± (Max.)
 B - ± 0,125" (3mm) E - ± (Min.)

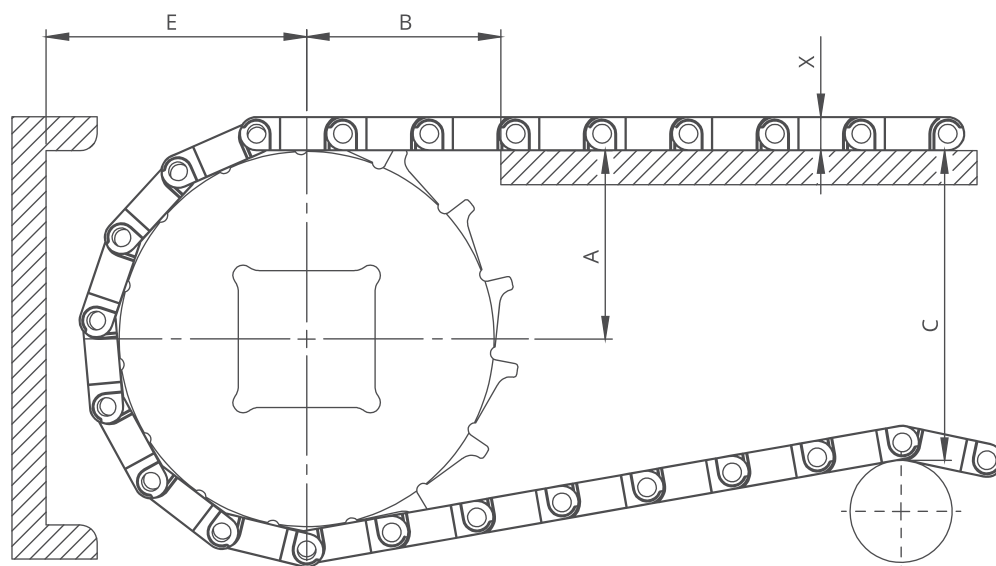

EC254 R Series / Conveyor Frame Dimensions

Sprockets Description			A		B		C		E		X	
Pitch Diameter		No.Teeth	Range (Bottom to Top)		inch	mm	inch	mm	inch	mm	inch	mm
inch	mm		inch	mm								
EC254 R												
2.38	60,5	8	1.15	29,2	1.55	39,4	1.95	49,5	1.94	49,2	0.43	11,0
3.07	78,0	10	1.46	37,1	1.77	45,0	2.60	66,1	2.25	57,1	0.43	11,0
3.74	95,0	12	1.76	44,8	1.97	50,1	3.24	82,3	2.55	64,8	0.43	11,0
4.70	119,5	15	2.22	56,4	2.23	56,7	4.18	106,1	3.01	76,4	0.43	11,0
5.02	127,5	16	2.37	60,2	2.38	60,5	4.46	113,2	3.21	81,5	0.43	11,0
5.71	145,0	18	2.73	69,3	2.45	62,3	5.19	131,8	3.51	89,3	0.43	11,0
EC254 R-GT												
2.38	60,5	8	1.15	29,2	1.55	39,4	1.95	49,5	2.18	53,7	0.61	15,5
3.07	78,0	10	1.46	37,1	1.77	45,0	2.60	66,1	2.48	61,6	0.61	15,5
3.74	95,0	12	1.76	44,8	1.97	50,1	3.24	82,3	2.79	69,3	0.61	15,5
4.70	119,5	15	2.22	56,4	2.23	56,7	4.18	106,1	3.25	80,9	0.61	15,5
5.02	127,5	16	2.37	60,2	2.38	60,5	4.46	113,2	3.46	86,0	0.61	15,5
5.71	145,0	18	2.73	69,3	2.45	62,3	5.19	131,8	3.76	93,8	0.61	15,5

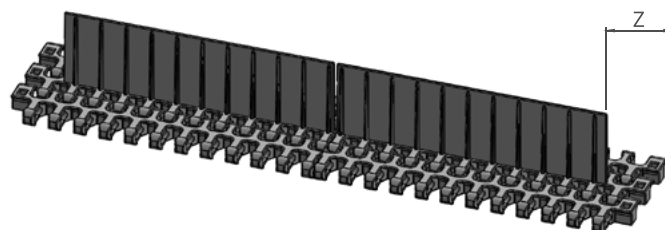
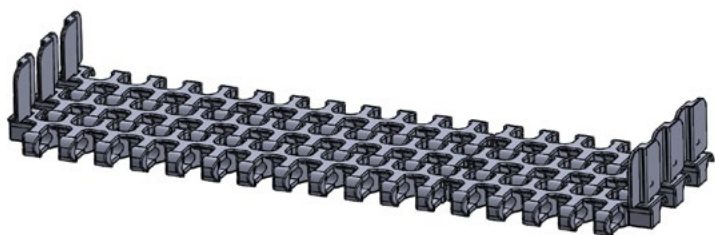

EC254 R Series / Sidewall Technical Specifications

Possible Sidewall Indents	-	
	mm	inch
Standard, no module cutting	-	-

EC254 R Series / Flight Technical Specifications

Possible Flight Indents for EC254 R Series	Z	
	mm	inch
Standard, no module cutting	25,0	0.98
Standard, module cutting	37,5	1.48
Standard, module cutting	54,3	2.14



EC254 R Series *Engineering Information*

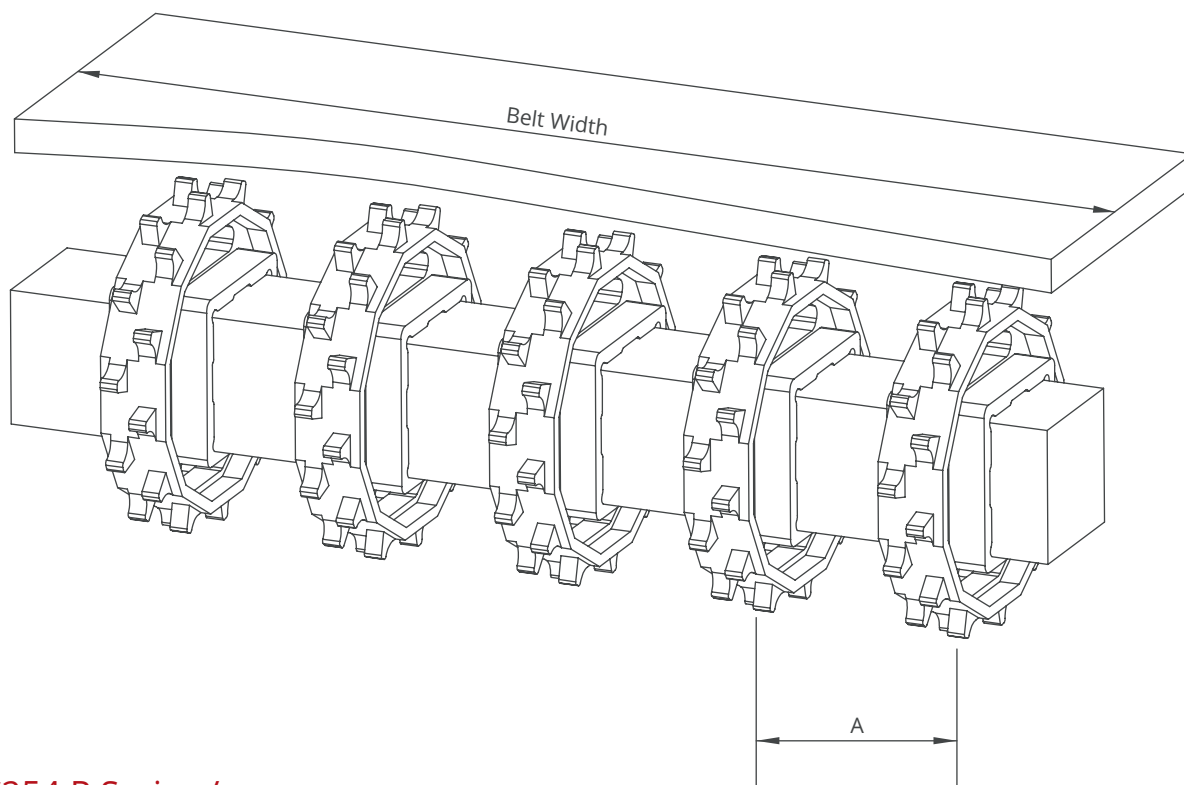

EC254 R Series / Sprockets Arrangement

Standard Belt Width		Number of sprockets per shaft			A (mm/inch)	
mm	inch	Drive Shaft		Return Shaft	Min.	Max.
150,0	6.0	2		2	50/2	120/4.7
200,0	8.0	2		2	50/2	120/4.7
250,0	10.0	3		2	50/2	120/4.7
300,0	12.0	3		2	50/2	120/4.7
350,0	14.0	3		3	50/2	120/4.7
400,0	16.0	4		3	50/2	120/4.7
450,0	18.0	4		3	50/2	120/4.7
500,0	20.0	5		4	50/2	120/4.7
550,0	22.0	5		4	50/2	120/4.7
600,0	24.0	6		5	50/2	120/4.7
700,0	26.0	7		5	50/2	120/4.7
800,0	28.0	8		6	50/2	120/4.7
900,0	30.0	9		7	50/2	120/4.7
1000,0	32.0	10		7	50/2	120/4.7

Note: Number of sprockets depends on the belt load.

EC254 R Series / Collapse Factors per widths for EC254 R Serie

Nom. Belt Width (mm)	250,0	300,0	350,0	400,0	450,0	500,0	550,0	600,0	650,0	700,0	750,0	800,0	850,0	900,0	950,0	1000,0	1050,0	1100,0	1150,0	1200,0
Nom. Belt Width (inch)	10.0	12.0	14.0	16.0	18.0	20.0	22.0	24.0	26.0	28.0	30.0	32.0	34.0	36.0	38.0	40.0	42.0	44.0	46.0	48.0
Collapse Factor	2,07	2,10	2,12	2,14	2,15	2,16	2,17	2,18	2,18	2,19	2,19	2,19	2,20	2,20	2,20	2,21	2,21	2,21	2,21	2,21
Min. Inner Radius (mm)	517,5	630,0	742,0	856,0	967,5	1080,0	1193,5	1308,0	1417,0	1533,0	1642,5	1752,0	1870,0	1980,0	2090,0	2210,0	2320,5	2431,0	2541,5	2652,0
Min. Inner Radius (inch)	20.7	25.2	29.7	34.2	38.7	43.2	47.7	52.3	56.7	61.3	65.7	70.8	74.8	79.2	83.6	88.4	92.8	97.2	101.7	106.1

Standard range of belt width and collapse factor (Min. Inner radius = Collapse factor x Standard belt width)



EC254T R

Modular Radius Belt Series

- **Meat Applications**

Spiral Freezer

- **Poultry Applications**

Spiral Freezer

- **Seafood Applications**

Freezing Lines, Spiral

- **Bakery Applications**

Spiral, Proofing, Cooling, Freezing Lines, Pan Handling

- **Fruits and Vegetables Applications**

Container Conveyence

- **Automotive Applications**

Car Part Manufacturing, Battery Filling

- **Packaging Applications**

Tray Packers, Box Transport Horizontal

- **Postal Applications**

Parcel Handling



EC254T R (Tight Radius)

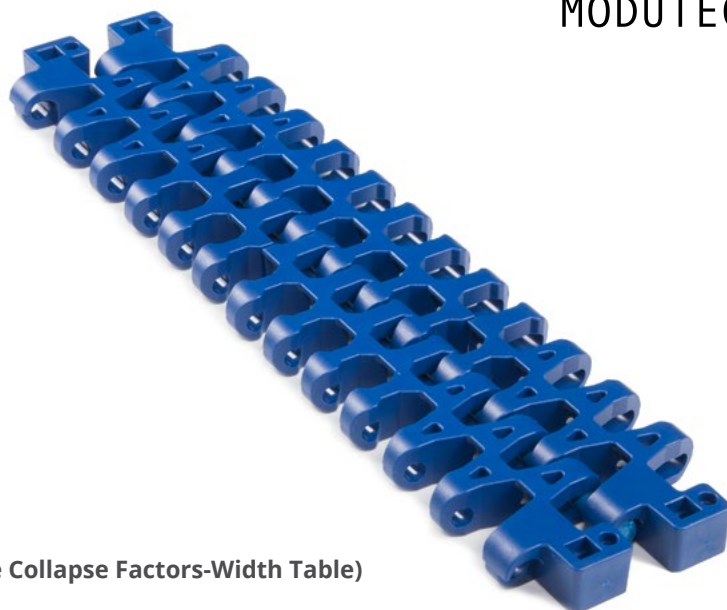

Pitch :	26 mm / 1 inch
Belt Surface :	Open, Smooth Surface
Minimum Width :	167 mm / 6.57 inch
Open Area (%) :	38%. (Biggest opening 6,5 x 12 mm)
Flight :	No
Side Wall :	Yes (h=25 mm)
Rod :	Ø5 mm / 0.197 inch - Self Lock
Approved :	FDA and EU
Curve :	Yes
Color :	Additional colors available
Cleanability :	Excellent
Application :	Straight and side flexing
Collapse Factor :	1.4 - 1.6 (Please check page 163 to see Collapse Factors-Width Table)
Belt Thickness:	13 mm / 0.512 inch

Product Features and Functional Benefits

- Belt designed for tight radius applications.
- Available for light and medium load capacity.
- 180 degree high speed side flexing applications.
- High temperature and wear resistance. Unique locking system.
- Belt provides optimal open area for drainage and airflow.

Available Moulded Module Sizes

- 200 mm / **7.87 inch** module
- 162 mm / **6.38 inch** module
- 137 mm / **5.39 inch** module
- 112 mm / **4.41 inch** module
- 100 mm / **3.94 inch** module
- 87 mm / **3.43 inch** module

EC254T R / Technical Information

BELT MATERIAL	BELT STRENGTH				TEMPERATURE		BELT WEIGHT
	Straight		Curve		°C (min.) - °F (min.)	°C (max.) - °F (max.)	
	N/m	lb/ft	N/m	lb/ft			Kg/m ² - lb/ft ²
Polypropylene	15400	1055	660	149	+5 / +42.8	+90 / +194	5,8 - 1.19
Polyethylene	-	-	-	-	-	-	-
Acetal	22000	1507	1210	272	-43 / -45.4	+110 / +230	8,4 - 1.72

- Belt strength and temperature values are maximum on the table.

EC254T R / Standard Belt Widths

BELT SERIES	WIDTH (W)				Belt With Tolerance (max.)
	PP		POM		
	mm	inch	mm	inch	
EC254T R	167,0	6.57	167,0	6.57	± 0,5 mm
EC254T R	200,0	8.0	200,0	8.0	± 2 mm
EC254T R	250,0	10.0	250,0	10.0	± 2 mm
EC254T R	300,0	12.0	300,0	12.0	± 3 mm
EC254T R	350,0	14.0	350,0	14.0	± 3 mm
EC254T R	400,0	16.0	400,0	16.0	± 3 mm
EC254T R	450,0	18.0	450,0	18.0	± 3 mm
EC254T R	500,0	20.0	500,0	20.0	± 4 mm
EC254T R	550,0	22.0	550,0	22.0	± 4 mm
EC254T R	600,0	24.0	600,0	24.0	± 4 mm
EC254T R	650,0	26.0	650,0	26.0	± 4 mm
EC254T R	700,0	28.0	700,0	28.0	± 4 mm
EC254T R	750,0	30.0	750,0	30.0	± 4 mm
EC254T R	800,0	32.0	800,0	32.0	± 4 mm

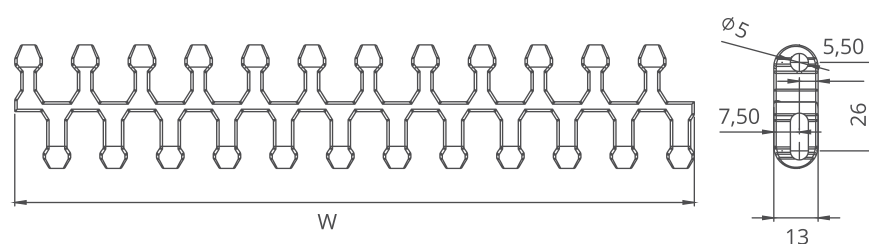

- Standard belt increments 50 mm.
- Non-standard increments 16,6 mm
- Please contact with customer service for precise belt measurements.
- For bigger sizes, please contact with customer service.

EC254T R Series Sprockets and Technical Specifications



Z15



Z8

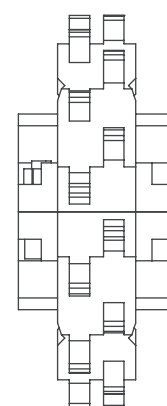
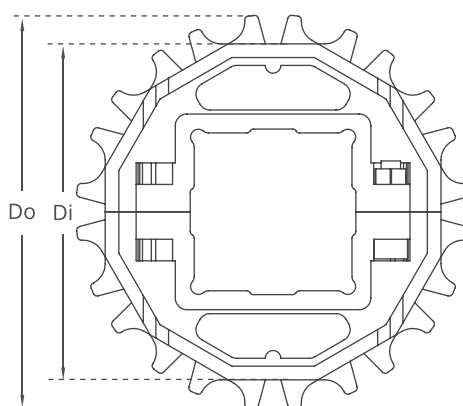
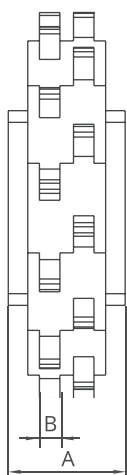
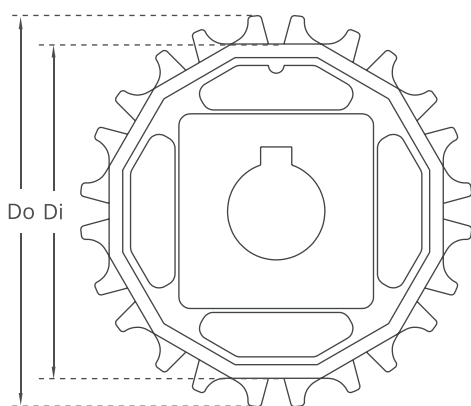

Split moulded sprockets are available.

EC254T R Series / Standard Sprockets Dimensions

NO. TEETH	Di mm/inch	Do mm/inch	B mm/inch	A mm/inch	Square Bore (Q) mm/inch	Round Bore (R) mm/inch	PRODUCT CODE	
							Square Type (Q)	Round Type (R)
Z8	52,0 / 2.05	67,0 / 2.64	6 / 0.24	30 / 1.18	25 / 1	25 / 1	MD-TR254SQ25Z8*POM	MD-TR254SRZ8*POM
Z10	69,0 / 2.72	84,0 / 3.31	6 / 0.24	30 / 1.18	40 / 1.5	25-30 / 1-1.25	MD-TR254SQZ10*POM	MD-TR254SRZ10*POM
Z12	85,84 / 3.38	100,84 / 3.97	6 / 0.24	30 / 1.18	40 / 1.5	25-30 / 1-1.25	MD-TR254SQZ12*POM	MD-TR254SRZ12*POM
Z15	110,8 / 4.36	125,8 / 4.95	6 / 0.24	30 / 1.18	40 / 1.5	25-30 / 1-1.25	MD-TR254SQZ15*POM	MD-TR254SRZ15*POM
Z16	119,1 / 4.69	134,1 / 5.28	6 / 0.24	30 / 1.18	40 / 1.5	25-30 / 1-1.25	MD-TR254SQZ16*POM	MD-TR254SRZ16*POM
Z18	135,63 / 5.34	150,58 / 5.93	6 / 0.24	30 / 1.18	40 / 1.5	25-30 / 1-1.25	MD-TR254SQZ18*POM	MD-TR254SRZ18*POM

*Other sprockets and hub sizes are manufactured up to request. *PA (Polyamide) and PP (Polypropylene) sprockets raw material is available on request.

***Machined Sprockets are available for each size.**



Clamp



Machined Split Sprocket

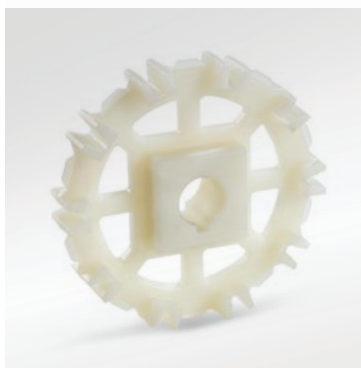

Moulded Sprocket

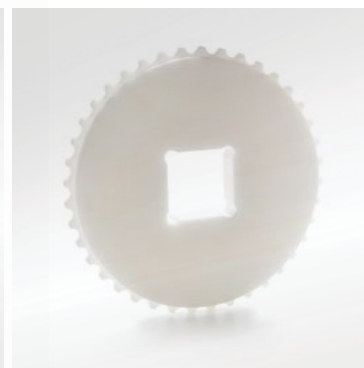

Machined Sprocket



EC254T R Series Accessories and Technical Specifications

EC254T R Series / TAB - Technical Specification

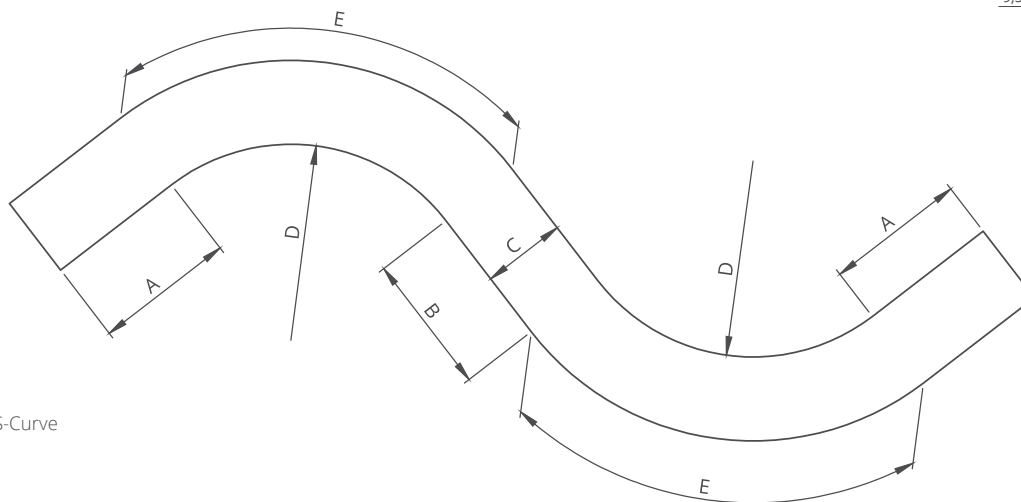
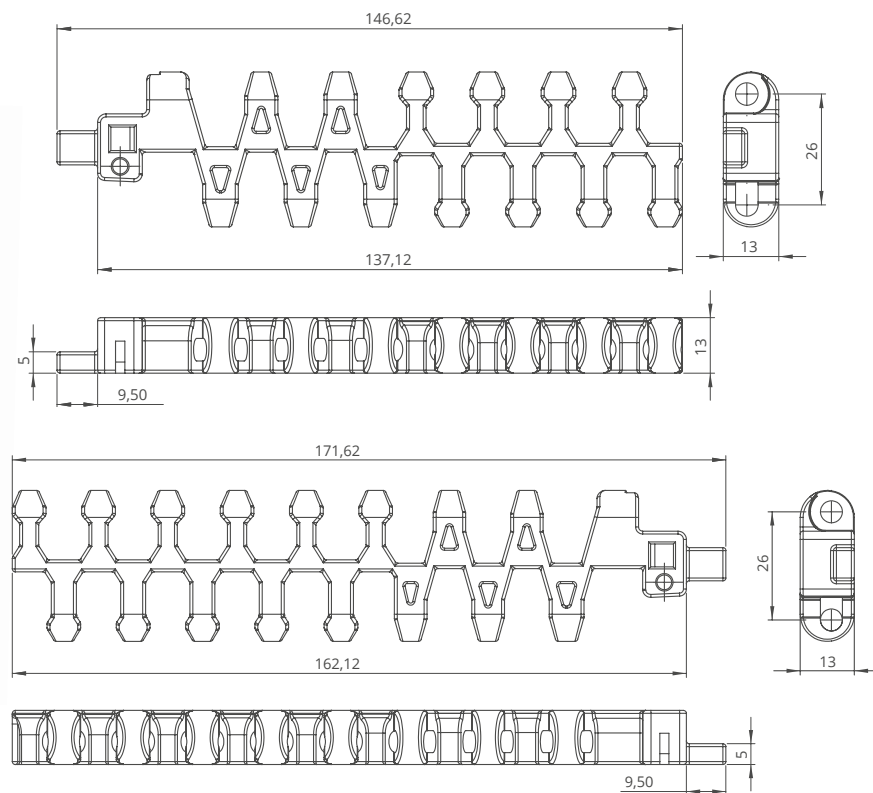

Radius Belt Example 90° S-Curve

EC254T R Series / Radius Belt Calculation

- A: Straight run pull and n = Belt width
- B: Straight run between 2 curves = min. 2 x belt width
- C: Belt width
- D: Minimum inner radius
- E: Curve length

$$\text{Collapse Factor} = \frac{\text{Min. inner radius}}{\text{Belt width}}$$

$$\text{Minimum inner radius} = \text{Collapse Factor} \times \text{Belt width}$$

CALCULATION EXAMPLE

Belt width: 500 mm Radius Belt
Collapse Factor: 1.55

$$D: 500 \text{ mm} \times 1.55 = 775 \text{ mm}$$

$$A: 500 \text{ mm}$$

$$B: 2 \times 500 \text{ mm} = 1000 \text{ mm (min.)}$$

$$E: \frac{2 \times (C+D) \times 3.14}{4} = 2016 \text{ mm}$$

$$\text{Total length} = (2 \times A) + B + (2 \times E)$$

EC254T R Series *Engineering Information*

A - ± 0,031" (1mm) C - ± (Max.)
 B - ± 0,125" (3mm) E - ± (Min.)

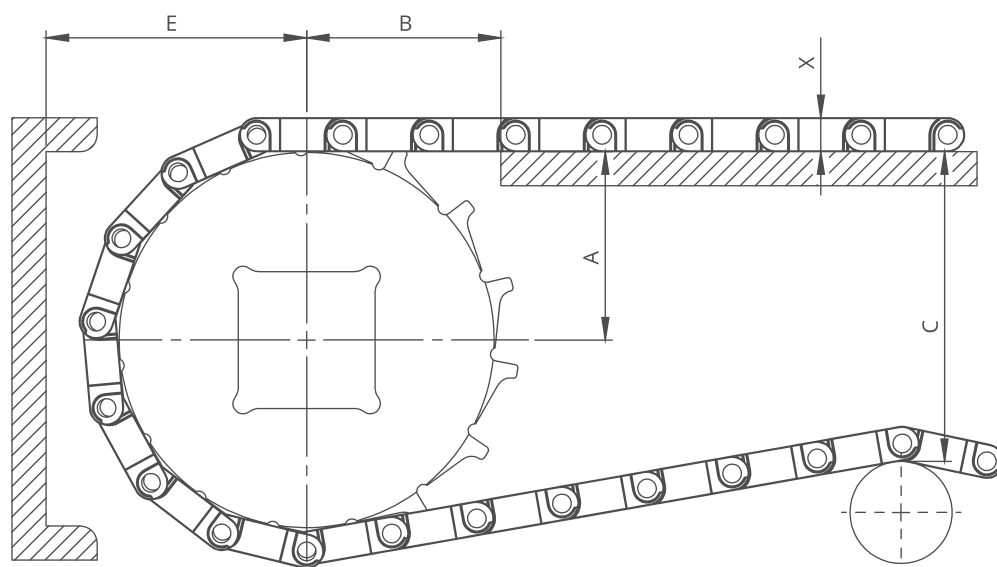

EC254T R Series / Conveyor Frame Dimensions

Sprockets Description			A		B		C		E		X	
Pitch Diameter		No.Teeth	Range (Bottom to Top)		inch	mm	inch	mm	inch	mm	inch	mm
inch	mm		inch	mm								
EC254T R												
2.38	60,5	8	1.15	29,2	1.55	39,4	1.95	49,5	1.94	49,2	0.43	11,0
3.07	78,0	10	1.46	37,1	1.77	45,0	2.60	66,1	2.25	57,1	0.43	11,0
3.74	95,0	12	1.76	44,8	1.97	50,1	3.24	82,3	2.55	64,8	0.43	11,0
4.70	119,5	15	2.22	56,4	2.23	56,7	4.18	106,1	3.01	76,4	0.43	11,0
5.02	127,5	16	2.37	60,2	2.38	60,5	4.46	113,2	3.21	81,5	0.43	11,0
5.71	145,0	18	2.73	69,3	2.45	62,3	5.19	131,8	3.51	89,3	0.43	11,0

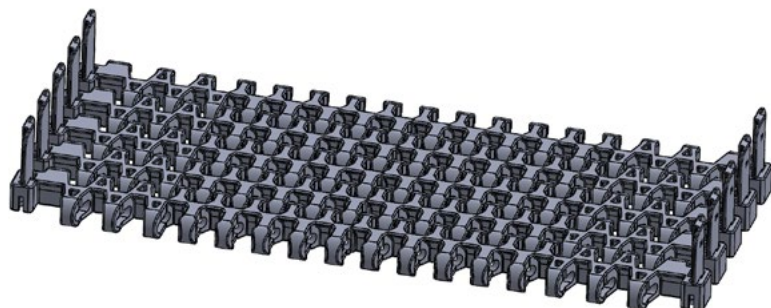

EC254T R Series / Sidewall Technical Specifications

Possible Sidewall Indents	-	
	mm	inch
Standard, no module cutting	-	-

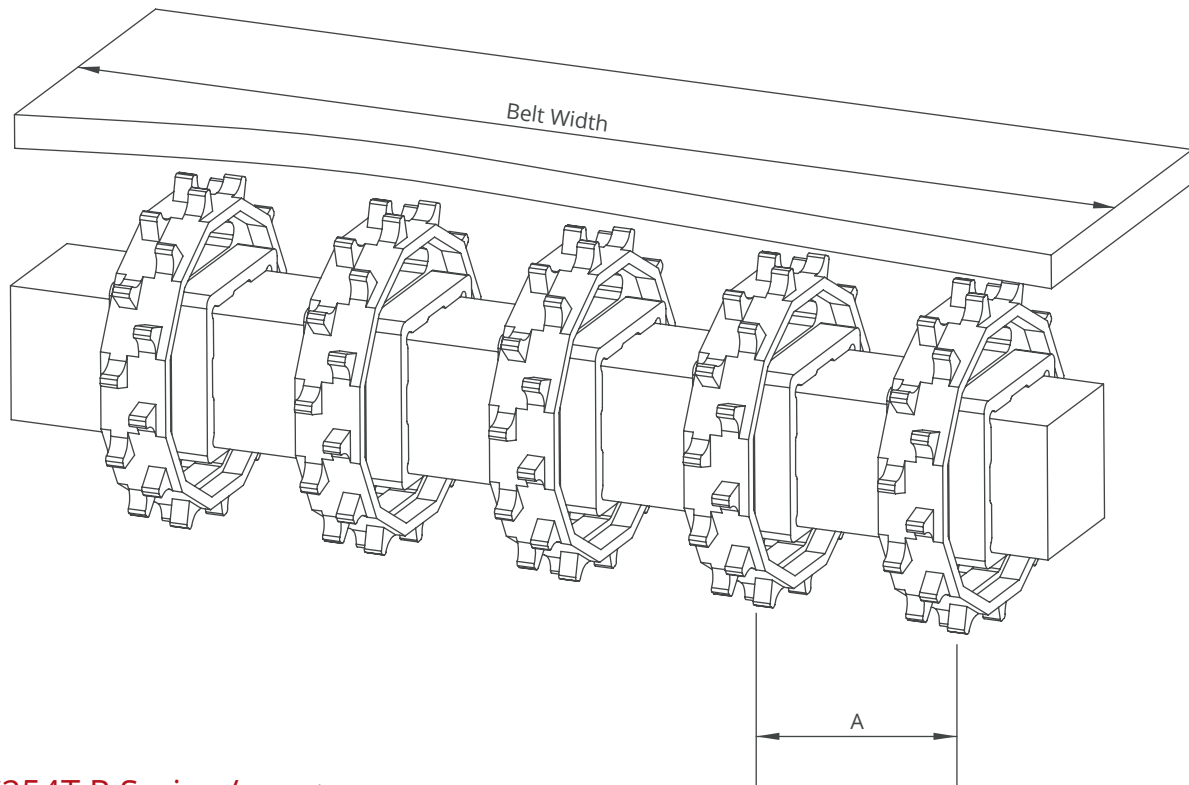

EC254T R Series / Sprockets Arrangement

Standard Belt Width		Number of sprockets per shaft		A (mm/inch)	
mm	inch	Drive Shaft	Return Shaft	Min.	Max.
167,0	6.57	2	2	50/2	120/4.7
200,0	8.0	2	2	50/2	120/4.7
250,0	10.0	3	2	50/2	120/4.7
300,0	12.0	3	2	50/2	120/4.7
350,0	14.0	3	3	50/2	120/4.7
400,0	16.0	4	3	50/2	120/4.7
450,0	18.0	4	3	50/2	120/4.7
500,0	20.0	5	4	50/2	120/4.7
550,0	22.0	5	4	50/2	120/4.7
600,0	24.0	6	5	50/2	120/4.7
700,0	26.0	7	5	50/2	120/4.7
800,0	28.0	8	6	50/2	120/4.7
900,0	30.0	9	7	50/2	120/4.7
1000,0	32.0	10	7	50/2	120/4.7

Note: Number of sprockets depends on the belt load.

EC254T R Series / Collapse Factors per width for EC254T R Serie

Nom. Belt Width (mm)	250,0	300,0	350,0	400,0	450,0	500,0	550,0	600,0	650,0	700,0	750,0	800,0	850,0	900,0	950,0	1000,0	1050,0	1100,0	1150,0	1200,0
Nom. Belt Width (inch)	10.0	12.0	14.0	16.0	18.0	20.0	22.0	24.0	26.0	28.0	30.0	32.0	34.0	36.0	38.0	40.0	42.0	44.0	46.0	48.0
Collapse Factor	1,43	1,47	1,50	1,52	1,54	1,55	1,56	1,57	1,58	1,58	1,59	1,61	1,62	1,63	1,64	1,65	1,66	1,66	1,70	1,71
Min. Inner Radius (mm)	357,5	441,0	525,0	608,0	693,0	775,0	858,0	942,0	1027,0	1106,0	1192,5	1288,0	1377,0	1467,0	1558,0	1650,0	1743,0	1826,0	1955,0	2052,0
Min. Inner Radius (inch)	14.3	17.6	21.0	24.3	27.7	31.0	34.3	37.7	41.1	44.2	47.7	51.5	55.1	58.7	62.3	66.0	69.7	73.0	78.2	82.1

Standard range of belt width and collapse factor (Min. Inner radius = Collapse factor x Standard belt width)

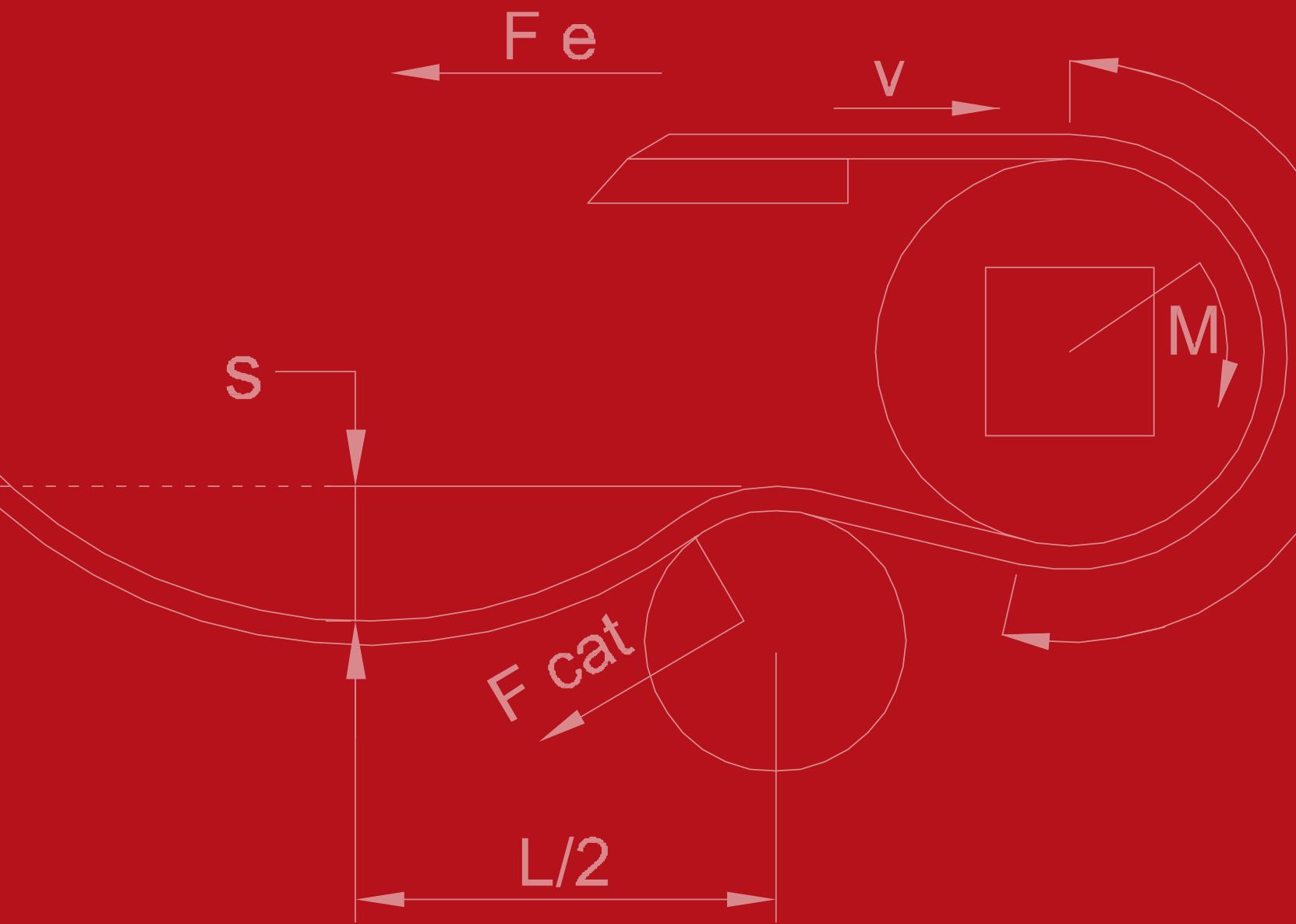

Engineering Guide

All Products

BELT CODE	Bakery	Meat	Poultry	Seafood	Fruit & Vegetables	Snackfood	Beverages & Bottling	Can Manufacturing	Tire Manufacturing	Automotive	Corrugated Cardboard	Packaging	Printing & Paper	Material Handling	Textile	Postal
MP80 C	*	*	*	*							*					
MP80 FG	*	*	*	*							*					
MP80 NS	*	*	*	*							*					
MP80 NP	*	*	*	*							*					
MD127 GAP%50	*			*	*										*	
HC127 C		*	*		*	*										
EC127 C	*	*	*	*	*	*	*	*	*		*	*	*	*		
EC127 FG	*	*		*	*	*	*	*			*	*	*	*		
EC127 GT	*	*	*	*	*	*	*	*			*	*	*	*		
XP254 C	*	*	*	*	*	*	*	*	*	*	*	*	*	*		
XP254 PR%22		*		*	*	*									*	
XP254 FG			*	*	*	*		*							*	
XP254 FLT CR							*	*		*	*		*		*	*
XP254 CR							*			*			*		*	*
EC254 C		*	*		*	*										
EC254 PR%16					*											
EC254 NT		*	*		*											
MD254 C	*	*	*	*	*	*	*	*			*	*	*			
MD254 FG	*	*	*	*	*	*	*	*	*		*		*	*		
MD254 RR					*	*	*				*		*			
MD254 GT	*	*	*	*	*	*	*				*		*			
MD254 GAP%48	*			*	*										*	
MD508 C					*	*		*	*		*		*			*
MD508 FG					*	*										
MD508 PR%25					*	*										
EC508 C		*	*	*	*	*					*		*			
EC508 PR%22			*	*	*	*					*					
EC508 PR%11				*	*						*					
EC508 PR%13				*	*						*					
EC508 FG				*	*	*		*			*					
EC508 DT			*	*	*	*										
EC508 NT		*	*	*	*	*										
EC508 FG-NT		*	*	*	*	*										
HP508 C					*	*	*	*	*	*	*		*			
HP508 RR					*	*	*				*			*		
HP508 FG									*							
EC254 R	*	*	*	*	*	*	*	*	*	*	*	*	*	*	*	*
EC254T R (Tight Radius)	*	*	*	*	*	*	*	*	*	*	*	*	*	*	*	*

BELT RAW MATERIAL / PINS RAW MATERIAL COMBINATION

	Applications	Belt Modules	Rods Pins
Standart	General Use Dry General Use Wet Chemical Resistance Low Temperature Low Temperature High Load Dry	PP PP PP PE POM POM	PP - POM - PA or PBT POM - PP or PBT PP or PBT PE - POM or PBT PE - POM or PBT PA or PBT
High Temperature	High Load Dry Wet 55 to 108 °C Temperature up to 180 °C	POM PPH (special) PA	PA or PBT PPH (Special) / Steel or PBT PA / Steel or PBT
Abrasive Conditions	Dry Wet up to 55 °C	POM PP	PA or PBT POM or PBT

STANDARD BELT MATERIALS WITH MODUTECH CODE				
Material	Description	Code	Food Approved	Temperature
Polypropylene	<ul style="list-style-type: none"> - Standard material for the most common conveying applications . - Excellent chemical resistance. 	PP	FDA - EU	+5 to +80 °C
Polyethylene	<ul style="list-style-type: none"> - Excellent chemical resistance . - Well suited for very low temperature with good impact resistance . - Not suitable for abrasive conditions. 	PE	FDA - EU	-70 to +60 °C
Polyacetal	<ul style="list-style-type: none"> - Good strength and low coefficient of friction . - Not suitable for chemical environment. - Suitable for heavy duty applications. 	POM	FDA - EU	Dry Conditions -38 to +90 °C Wet Conditions -35 to +60 °C

STANDARD BELT RAW MATERIALS WITH MODUTECH CODE				
Material	Description	Code	Food Approved	Temperature
Polyamide6	<ul style="list-style-type: none"> - High strength and abrasion resistance. - Suitable for heavy duty applications. - Not suitable for wet conditions. 	PA6	FDA - EU	Dry Conditions -35 to +120 °C Wet Conditions Not Recommended
Polyamide6.6	<ul style="list-style-type: none"> - Better strength and abrasion resistance. - Suitable for heavy duty applications. - Not suitable for wet conditions. 	PA6.6	FDA - EU	Dry Conditions -35 to +120 °C Wet Conditions Not Recommended
Antistatic Polyacetal	<ul style="list-style-type: none"> - Reduced electrical surface to reduce belt charge up and dust accumulation. - Suitable for heavy duty applications and low temperature. 	POM	-	Dry Conditions -35 to +80 °C Wet Conditions Not Recommended
Detectable Polyacetal	<ul style="list-style-type: none"> - Polyacetal with a special additive, which makes the material very well detectable for X-ray and metal detectors. 	POM	FDA - EU	Dry Conditions -38 to +90 °C
Detectable Polypropylene	<ul style="list-style-type: none"> - Polypropylene with a special additive, which makes the material very well detectable for X-ray and metal detectors. 	PP	FDA - EU	+5 to +90 °C
Hot Water Resistant Polypropylene	<ul style="list-style-type: none"> - Polypropylene with a special additive to improved temperature resistance. - Suitable for wet conditions. 	PPH	FDA - EU	+5 to +115 °C
Low Friction Acetal	<ul style="list-style-type: none"> - Better strength and low coefficient of friction. - Not suitable for chemical environment. - Suitable for heavy duty applications. 	POM LF	FDA - EU	+5 to +108 °C
High Performance Acetal (PBT)	<ul style="list-style-type: none"> - Extra wear resistance, strength and, low coefficient of friction. - Not suitable for chemical environment. - Suitable for heavy duty applications. 	POM HP	FDA - EU	-35 to +90 °C
Extra High Temperature (EHT)	<ul style="list-style-type: none"> - Excellent heat resistance. - Suitable for light-medium duty applications at elevated temperatures. 	PA EHT	-	Dry Conditions +4 to +210 °C Wet Conditions No Request
Flame retardant Polypropylene	<ul style="list-style-type: none"> - Flame retardant thermoplastic material for low-flammability. - High impacts below 10 °C must be avoided. 	PP FR	-	+5 to +105 °C
Electrically conductive Polyoxymethylene (Acetal)	<ul style="list-style-type: none"> - Low electrical surface and volume resistance. - Electrical surface resistivity (ps) below 50'000 Ohm/sq. - High strength and low coefficient of friction. - Suitable for heavy duty applications and low temperatures. 	POM EC	-	Dry Conditions -40 to +93 °C Wet Conditions No Request
Impact and cut resistant Polyoxymethylene (Acetal)	<ul style="list-style-type: none"> - Advanced impact and cut resistant surface. - Suitable for meat cutting conveyors and high impact applications. - Good chemical resistance to oil and alkalines, but not suitable for long-term contact with high concentration of acids and chlorine. 	POM ICR	FDA - EU	Dry Conditions -40 to +93 °C Wet Conditions -40 to +60 °C

By its construction, the modular belt length varies according to various factors such as tension, temperature and wear.

It is therefore not possible to apply tension to the belt by stretching it between fixed shafts.

Belt tension on the drive sprocket is necessary to avoid the belt jumping on the sprocket itself. This tension is obtained by leaving a portion of belt suspended immediately after the sprocket.

This belt portion forms a dip that in addition to providing the return tension (F_{cat}) also allows the recovery of belt elongation between sections.

Values "L" and "S" determine the value of F_{cat} . Values of "S" too small or "L" too large lead to excessive belt tension.

The belt weight and the geometry of the dip determine F_{cat} . It is also important to ensure that the wrapping angle of the belt on the sprocket is between 170° and 210° .

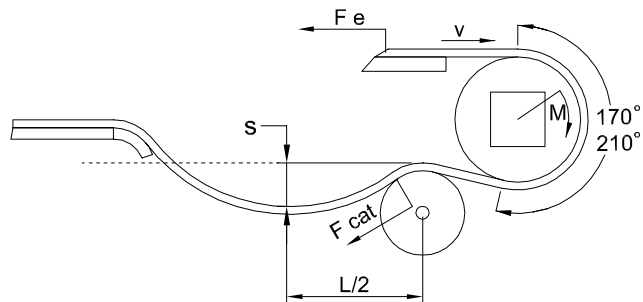

For a correct belt tension that optimizes the belt wear and tear it is important to verify that the "L" and "S" dimensions are in the following range. The return path of the belt may be supported in different ways or not supported, depending on the belt length.

S Range Suggested Values (mm)					
L (m)	Belt Weight (Kg/m ²)				
-	4	8	10	12	14
0,9	20-40	25-60	30-70	40-90	50-100
1,1	25-50	40-90	50-100	60-120	70-130
1,3	30-70	50-100	60-120	70-150	80-160

If the belt has guides, it may be necessary to have an indent for the guides in the return path (if it is needed: F over 2 m). In case of particularly wide strips, it is appropriate to provide the interruption of the flights also in the central part to allow the belt suspension with a further guide.

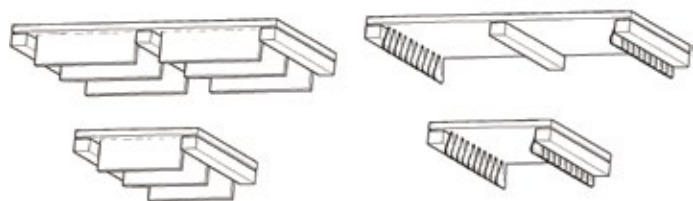

"R" minimum in (mm)	127 Series	254 Series	508 Series
Max. belt width not supported	800	1000	1000

Horizontal Conveyors

Case of maximum center distance F 2 meters.

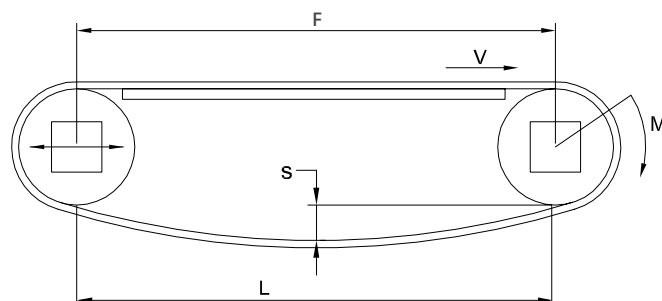

Case of center distance F between 2 - 4 meters.

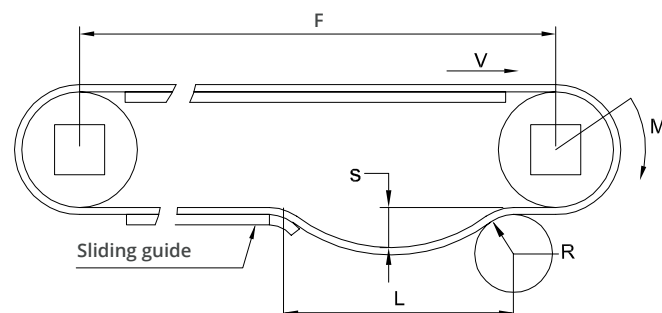

Case of center distance F over 4 meters (if over 20 meters it is suggested a gravity tensioner device after the drive shaft since the belt length variation can be too large to guarantee a correct dip amount).

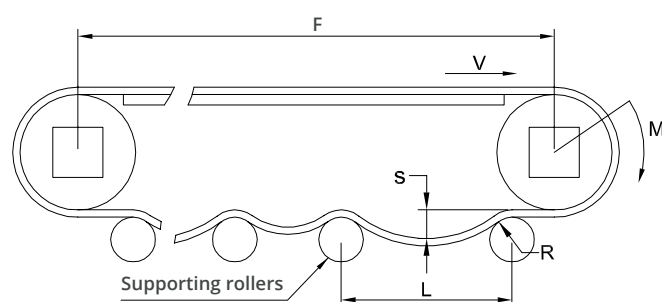

"R" minimum in (mm)		
Belt Series	Belt with flights	Belt without flights
127 Series	25	120
254 Series	25	150
508 Series	50	200

(*) $900 < L < 1200$ mm

It is recommended that the distances between the supporting rollers vary between L_{max} and L_{min} .

Escalators

For all escalator configurations, the guiding principles are still valid, it is necessary to ensure a minimum tension on the return stroke, a dip sufficient for the belt length variation and able to support the belt on the return stroke.

The position of the dip in most cases should be placed at the base of the escalator, but if the friction of the belt is such that it does not allow it to slide on the return path, the dip will be at the top immediately after the drive shaft.

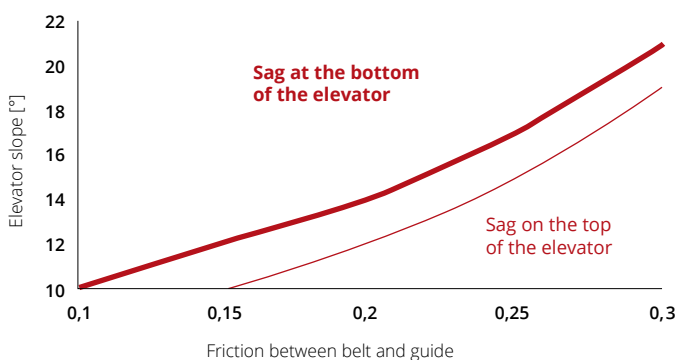
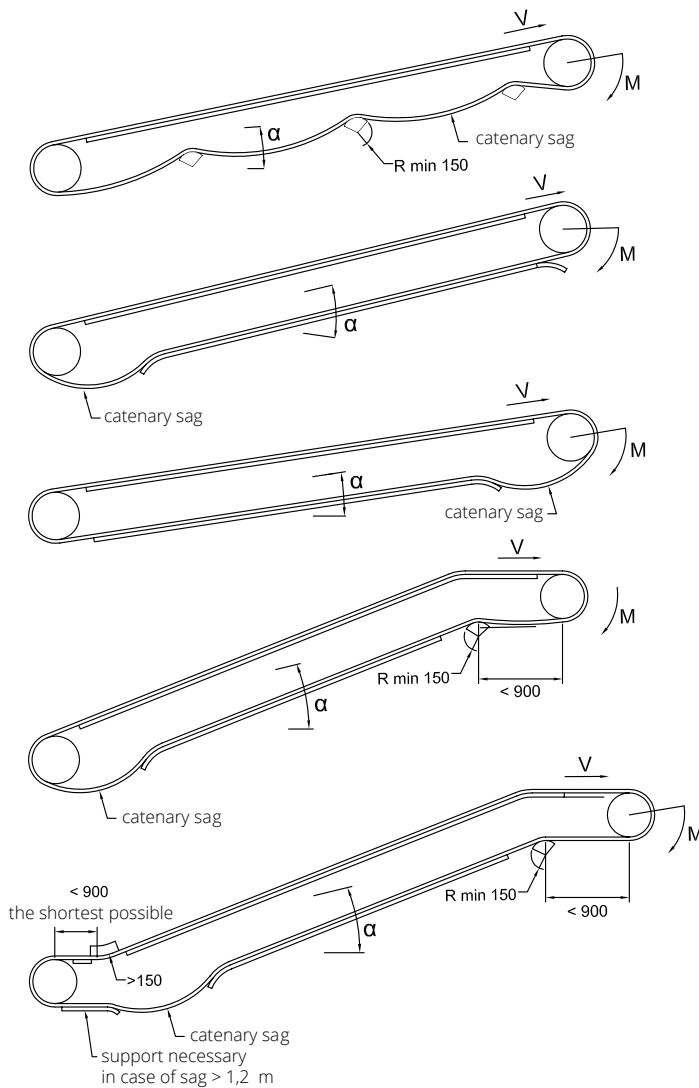

Frequently, belts with guides are used for escalators. In this case, as with horizontal conveyors, the belt edges must allow space for the guides, and if the width exceeds the width limit values, a central support should also be provided.

In case the belt does have sidewalls, the minimum back bending diameters must be checked. In the case of lifting with back bending closed to the driven shaft, the horizontal section has to be as short as possible.

Additionally, since it is not possible to support the belt in the area of the guide, it is suggested to limit the belt width as shown in the following table:

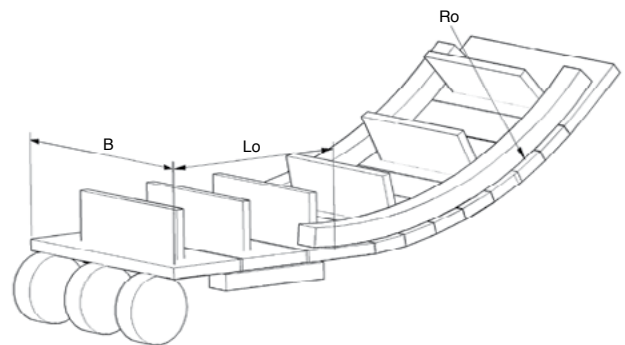

Series	127 Series				254 Series			
Load	<50%		>50%		<50%		>50%	
Length Lo [mm]	<800	800 - 2000	<800	800 - 2000	<800	800 - 2000	<800	800 - 2000
Width B max [mm]								
Slope <45°	1500	1200	1000	800	1200	1000	800	600
Slope >45°	1050	NR	700	NR	850	NR	550	NR

Ro = minimum radius = 150 mm
NR = Not Recommended

Series	508 Series			
Load	<50%		>50%	
Length Lo [mm]	<800	800 - 2000	<800	800 - 2000
Width B max [mm]				
Slope <45°	700	550	500	400
Slope >45°	500	NR	300	NR

Ro = minimum radius = 150 mm
NR = Not Recommended

Horizontal conveyors

• Common drive configuration

Slider support on return way, or rollers alternatively. For proper sprocket engagement maintain approx. 180° arc of contact.

• Uni-directional drive

One motor (M) at conveyor end, pull action (driving sprockets are pulling the belt). Catenary sag (CA) only required on drive end.

• Lower head drive

For tight transfer with nosebar or with small idling rollers the motor with the drive shaft can be arranged as illustrated.

• Bi-directional drive

Two motors (M), one at each conveyor end. Only one motor is pulling, the other motor remains disengaged (clutch). Catenary sag (CA) at both conveyor ends.

• Bi-directional center drive

Only one motor (M) placed in the middle of the belt return. This system works well for bi-directional conveyors. In case of high loads a gravity take-up may be necessary for positive sprocket engagement. Optional solutions: pneumatic or spring-loaded tensioning device. Solutions: pneumatic or spring-loaded tensioning device. Center drives are not recommended for radius applications.

Since the driving force is applied on the return way of the belt, the shaft load will be two times the calculated belt pull:

$$F_w = 2 \cdot F'_e$$

Bi-directional conveyor and pusher drive (push/pull action) It is possible to apply one head drive motor for bi-directional reversible driving.

For reverse driving (push action = pusher drive), a screw type take-up (TU), or a spring or a pneumatic tensioning device with 110% pretension of the expected belt load is recommended. The shaft load will increase to:

$$F_w = 2.2 \cdot F'_e$$

In case of a bi-directional pusher drive with tensioning device, the shaft load can increase to:

$$F_w = 3.2 \cdot F'_e$$

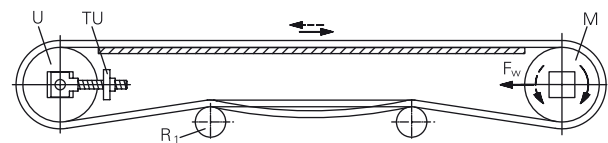
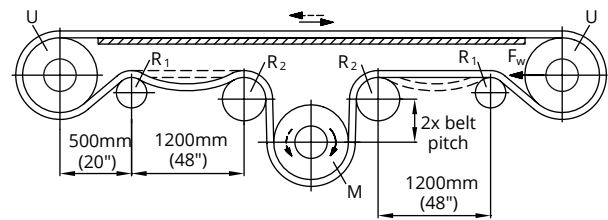
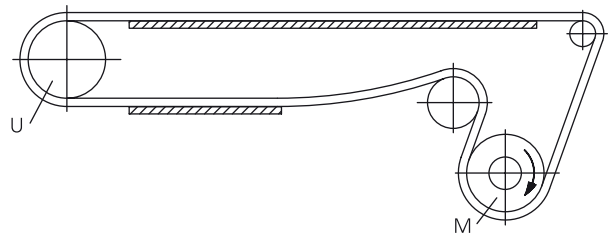
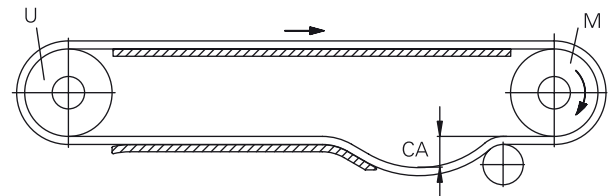

CONVEYOR LENGTH - MAXIMUM SPEED

Conveyor Length	Max. Speed
up to 15 m (45 ft)	50 m/min (150 ft/min)
15 m - 25 m (45 - 75 ft)	30 m/min (90 ft/min)
over 25 m (75 ft)	15 m/min (45 ft/min)

Belt Guiding

• Belt guides and hold-down tabs

Radius belts running around curves are radially pressed against the inner guide rail of the curve. Since the conveyors usually cannot be built at very high geometrical accuracy, the belt may tend to flip over at high loads or angles > 90°. At the inner edge the belt may move upwards while it is radially pressed against the guide rail and slip off.

For this reason hold-down edge guides must be used for the in- and outside guide of a curve. If the product is larger than the belt width or if side transfer over the belt edge is required, hold-down modules or side tabs are used instead of hold-down guides.

• Standard application (hold-down edge guides)

If no side transfer is required, L-shaped hold-down edge guides can be used. Respect the min. gap between belt and guides. For safety reasons (danger of injuries at end of profile) it is advisable to apply this profile uninterrupted over the complete belt length. The material used for edge guides needs to be low friction in contact with the particular belt material. Generally, UHMW PE is recommended. On the return way, hold-down tabs are needed as well. An economic solution is shown on the illustration beside. For belts wider 600 mm hold-down edge guides or 2 hold-down tabs near the edges should be used.

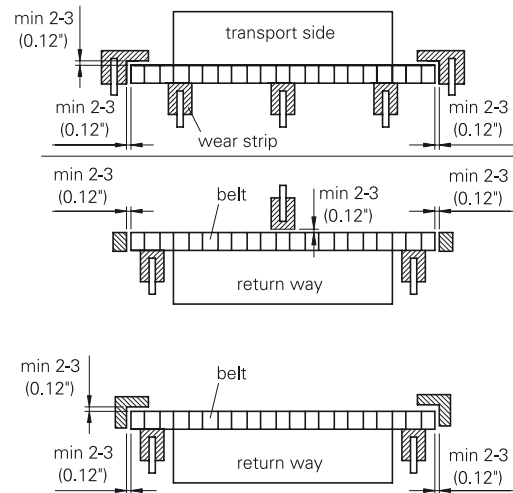

Hold-down guides for belt with flights. Belts without flights follow the same design.

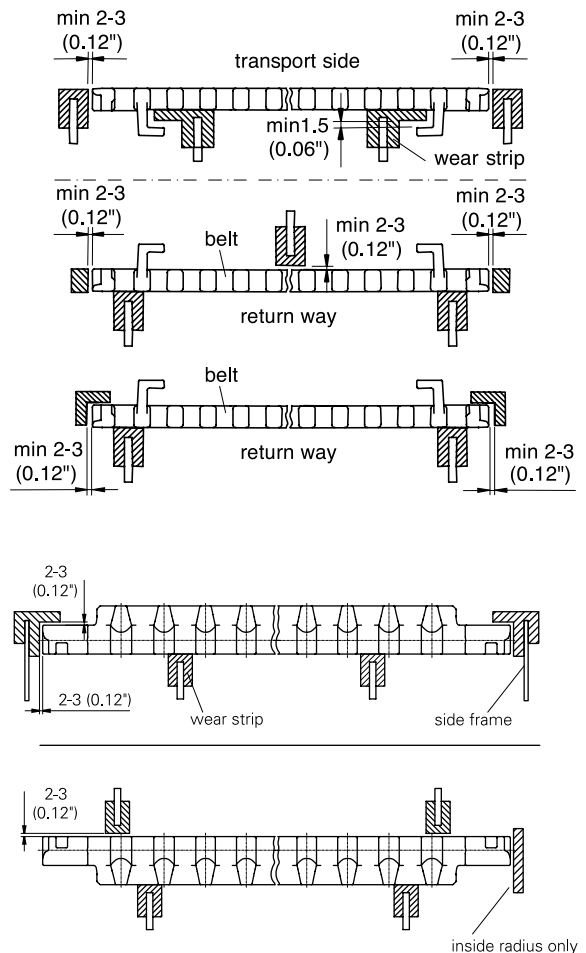

• **Belts for product side transfer**

Belts with hold-down tabs; side tabs or raised deck can be used for all application where products must be moved transversally across the belt edge (side transfer) and in case where the product is wider than the belt itself.

For application with side guards belts with hold-down tabs are conditionally possible and belts with side tabs or raised deck are not applicable.

• **Note**

The hold-down or side tabs should not be used for radial guidance or to support (guide) the belt on its return way. They can be worn away too quickly.

• **High speed applications**

For speeds > 40 m/min it is recommended to use prelubricated materials or stainless steel for radius guides. To keep the temperature low, prefer guide material with best possible heat conduction properties (e. g. PA prelubricated or stainless steel).

• **Tensioner**

On Z-conveyors catenary sags may not be accepted, neither on the upper nor on the lower horizontal belt section. This may be due to lack of space under the bottom conveyor end or too short horizontal sections. It must be strongly recommended to use a self-adjusting tensioner device.

This can be a soft spring type, gas loaded spring or pneumatic tensioner type. The optimal layout of the spring or pneumatic cylinder is depending on the belt type, conveyor width and temperature conditions. The minimum free movement of the tensioner must be min. 20% more than the calculated belt elongation between lowest and highest process temperature. The belt elongation due to abrasion should also be considered.

For straight running belts:

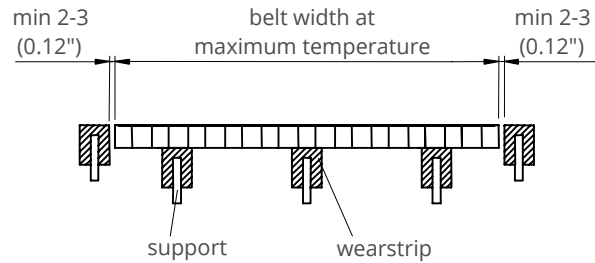

For radius belts:

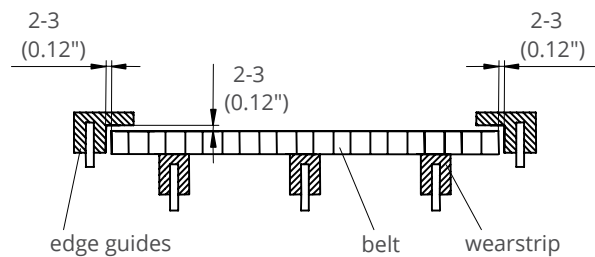

The force should be as low as possible, but high enough to overcome eventual friction forces of the belt on its return way, to straighten it and to engage the sprockets safely. As a general rule the following tensioner force is proposed:

Belt type	Tensioner force per m(ft) of belt width
127 Series	15 kg / 10 lb
245 Series	15 kg / 10 lb
508 Series	30 kg / 20 lb

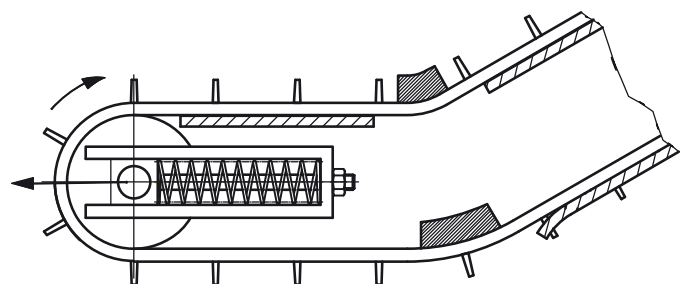

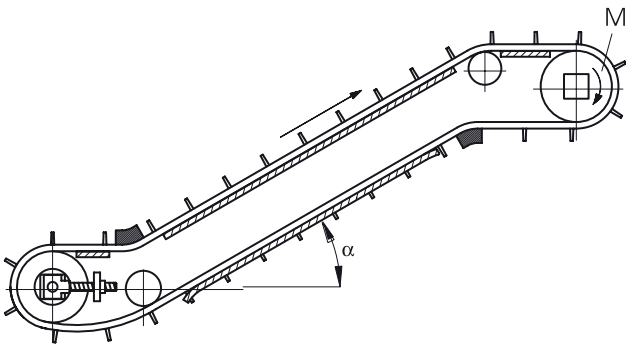
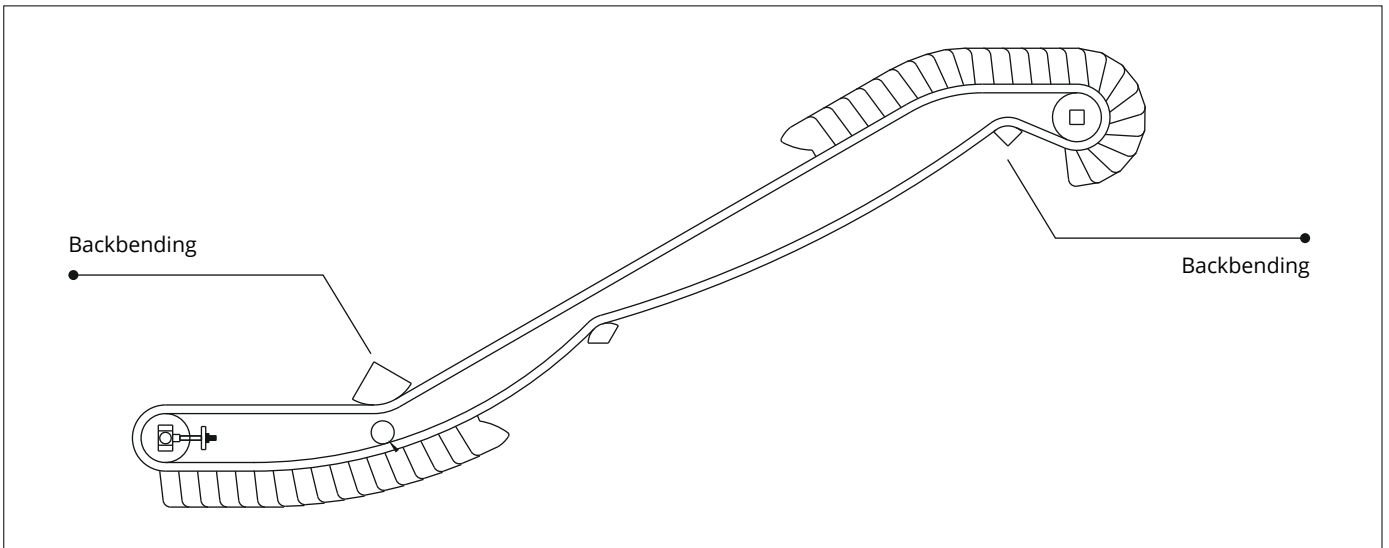

Tight transfer

For 127 Series "pitch, "sliding bars" can be used to minimize space between two belts or between belt and table. The sliding bar can be placed on one or both ends of the belt.

The back bending roller should be larger than the regular roller support.

In this case, it is also important to ensure the presence of the dip and the contact arc on the sprockets.

Belt Series	Nosebar Diameter		Minimum backbending roller diameter		Backbending radius for elevators Z-conveyor without sidewalls		Backbending radius for elevators Z-conveyor with sidewalls	
	mm	inch	mm	inch	mm	inch	mm	inch
MP80	6,0	0.28	50,0	2.0	-	-	-	-
MD127	18,0	0.7	75,0	3.0	-	-	-	-
HC127	18,0	0.7	75,0	3.0	-	-	-	-
EC127	18,0	0.7	75,0	3.0	150,0	6.0	-	-
EC254	-	-	100,0	4.0	150,0	6.0	250,0	10.0
XP254	-	-	100,0	4.0	150,0	6.0	250,0	10.0
MD254	-	-	100,0	4.0	150,0	6.0	250,0	10.0
EC508	-	-	150,0	6.0	200,0	8.0	250,0	10.0
HP508	-	-	150,0	6.0	200,0	8.0	250,0	10.0
MD508	-	-	150,0	6.0	200,0	8.0	250,0	10.0

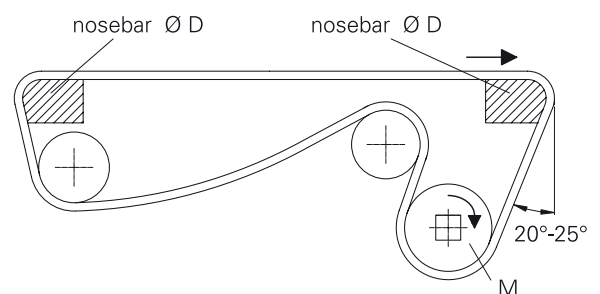
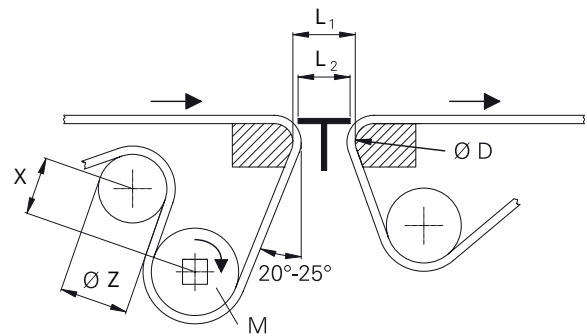

Series	MP80 Series		HC127 & MD127 Series		EC127 Series	
	mm	inch	mm	inch	mm	inch
Minimal backbending roller diameter Z	50,0	2.0	75,0	3.0	75,0	3.0
Minimal straight belt section X between drive and snub roller	50,0	2.0	50,0	2.0	50,0	2.0
Distance L1 between nosebars	16,0	0.6	22,0	0.9	30,0	1.2
Distance L2 Max. width of transport plate	-	-	16,0	0.6	25,0	1.0
Recommended nosebar diameter D	6,0	0.24	12,7	0.5	18,0	0.7
Minimal nosebar diameter D min	6,0	0.24	12,7	0.5	16,0	0.6

General Sprocket Installation

To allow the belt to expand/contract only the central sprocket on each shaft is fixed. For shafts with 2 sprockets, the sprockets on the drive shaft is fixed.

Different locking methods are possible:

- **Set the collars and screws**
Commonly used in round shafts with keyways
- **Retainer Rings**
Commonly used in square shafts
- **Retaining Plate**
Low cost method for square shafts

There should be 0.3 mm / 0.01 inch between sprocket and retainer ring. Please be sure all the retainer rings securely fastened.

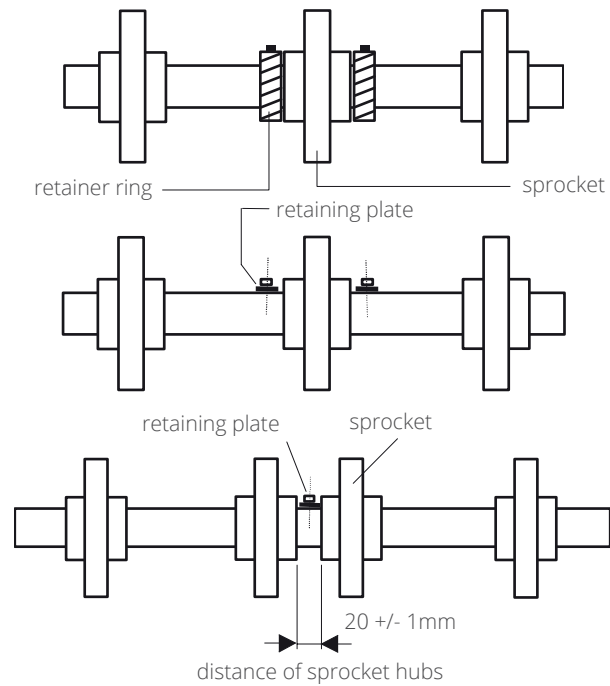

Metric		Keyway Table									
ØD	mm	20,0	25,0	30,0	35,0	40,0	50,0	60,0	70,0	80,0	90,0
a	mm	2,80	3,30	3,30	3,30	3,30	3,80	4,40	4,90	5,40	5,40
b	mm	6,0	8,0	8,0	10,0	12,0	14,0	18,0	20,0	22,0	25,0

Imperial		Keyway Table									
ØD	inch	0.75	1.0	1.25	1.50	2.0	2.50	2.75	3.25	3.50	4.50
a	inch	0.098	0.130	0.130	0.193	0.256	0.319	0.319	0.370	0.429	0.488
b	inch	0.17	0.25	0.25	0.375	0.5	0.625	0.625	0.75	0.875	1.0

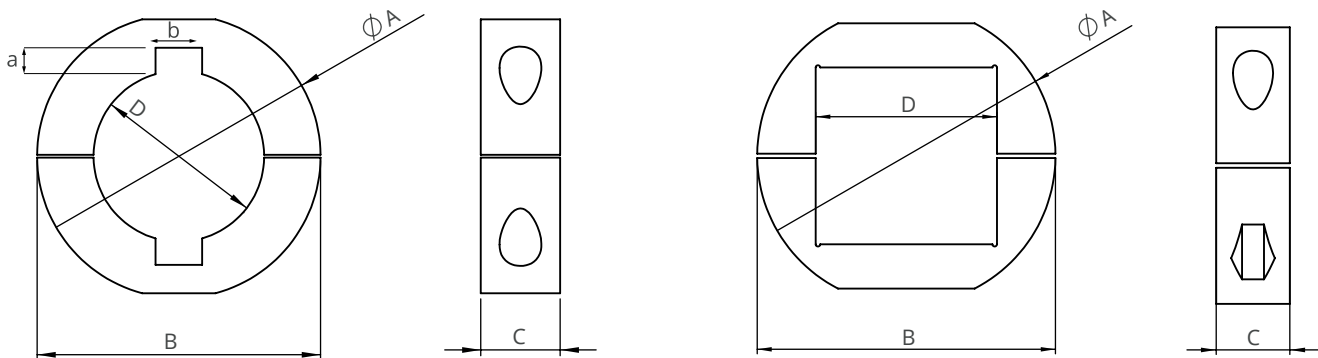

Round Bore Clamp Dimensions			
D	A (mm)	B (mm)	C (mm)
SR20	39,0	39,0	14,0
SR25	44,0	44,0	14,0
SR25,4	44,0	44,0	14,0
SR30	50,0	50,0	14,0
SR31,75	50,0	50,0	14,0

Square Bore Clamp Dimensions			
D	A (mm)	B (mm)	C (mm)
SQ25	51,0	51,0	14,0
SQ25,4	51,0	51,0	14,0
SQ38,1	67,5	67,5	16,0
SQ40	67,5	67,5	16,0
SQ60	100,5	100,5	16,0
SQ63,5	100,5	100,5	16,0

Effective Tensile Force

• **Horizontal straight belt without accumulation**

$$F'_E = (2 m_B + m_P) l_0 \cdot \mu_G \cdot g \text{ [N/m]}$$

• **Horizontal straight belt with accumulation, simplified**

$$F'_E = [(2 m_B + m_P) l_0 \cdot \mu_G + m_P \cdot \mu_P \cdot l_a] g \text{ [N/m]}$$

• **Inclined conveyor without accumulation**

$$F'_E = [(2 m_B + m_P) l_1 \cdot \mu_G + m_P \cdot h_0] g \text{ [N/m]}$$

• **Inclined conveyor with accumulation, simplified**

$$F'_E = [(2 m_B + m_P) l_1 \cdot \mu_G + m_P \cdot \mu_P \cdot l_a + m_P \cdot h_0] g \text{ [N/m]}$$

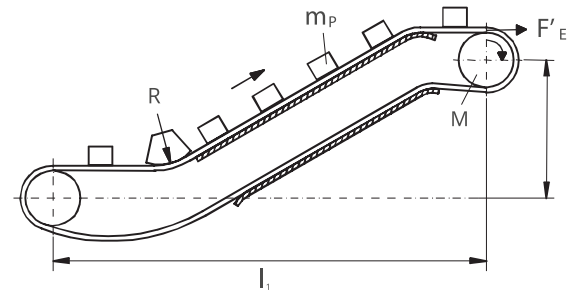
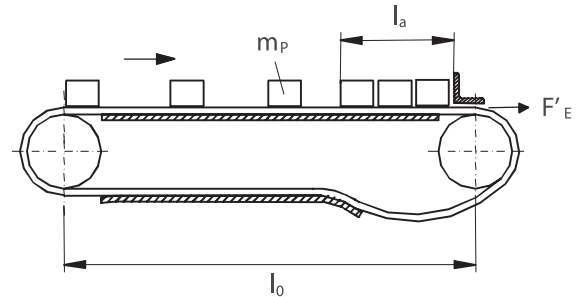

Further analyses of tensile forces caused by accumulated products above equations with accumulation are based on the simplification that the product load per m² of belt is the same over the accumulation length as when moving with the conveyor. This is generally not the case. In reality the density of the product distribution over the accumulation length l_a will be higher (can be double or 3 times). Since this value will often not be known it is common practice to use the same product load value for product load value for conveying. In this case the above formulas are used. The calculated force is somewhat too low, but normally not critical for straight belts. If the accumulated product load per m² is known, and for more accurate calculation, it is proposed to replace m_p in the term $m_p \cdot \mu_p \cdot l_p$ by m_{pa}

The following formulas result:

• **Horizontal straight belt with accumulation**

$$F'_E = [(2 m_B + m_P) l_0 \cdot \mu_G + m_{Pa} \cdot \mu_P \cdot l_a] g \text{ [N/m]}$$

• **Inclined conveyor with accumulation**

$$F'_E = [(2 m_B + m_P) l_1 \cdot \mu_G + m_{Pa} \cdot \mu_P \cdot l_a + m_P \cdot h_0] g \text{ [N/m]}$$

- F'_E = Effective tensile force [N/m]
- m_B = Weight of belt [kg/m²]
- m_P = Weight of conveyed product [kg/m²]
- m_{Pa} = Weight of accumulated product [kg/m²]
- μ_G = Coefficient of friction belt to slider support
- μ_P = Coefficient of friction belt to product
- l_0 = Conveying length [m]
- l_a = Length of accumulation [m]
- h_0 = Height of elevation [m]
- g = Acceleration factor due to gravity (9.81 m/s²)

Effective Tensile Force

• **Radius belts**

Radius belts have higher friction losses than straight belts due to the radial forces directed to the inside of the curve. It also has to be taken into account, that in the belt curves the tensile forces are not distributed over the edge.

For calculation of radius belts please ask your Modutech® representative.

• **Note**

Due to the concentration of the belt pull (tensile forces) on the outer belt edge at curve end, the applicable number of curves is very limited. In practice 1 to 2 curves are often used. For long radius belts it is advisable to place the curve as near to the idling shaft as possible. This way the belt pull at the outer curve edge is minimized.

• **Nominal strength for radius belts in curve**

The nominal strength for radius belts in curve increases with wider belts (bigger radius). Due to the smaller angle between the modules the forces are distributed on more links. In case of high loads the application of steel rods may be advisable to increase the belt stiffness. Please contact your Modutech® representative for detailed information.

Appropriate quality of the conveyor especially smooth and low coefficient of friction inside wear strips and smooth start-up are important. Belt at return way must be properly held down by wear strips or hold-down tabs .

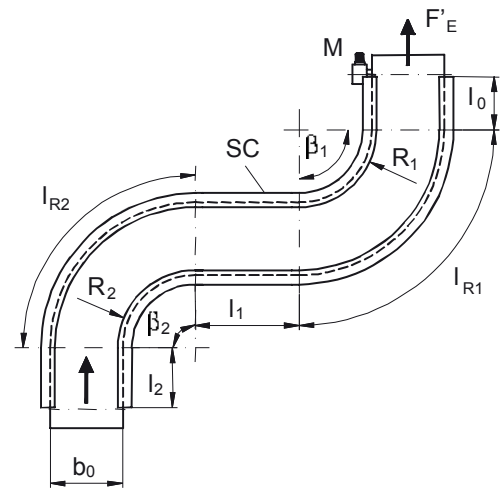

F_{SR} = Absolute tensile force [N]
 F'_E = Effective tensile force [N/m]
 b_0 = Belt width [m]
 c_s = Service factor

FRICTION FACTORS									
Friction Factors	Friction between wearstrip and belt material				Friction between product and belt product material (used in backup conditions)				
Belt Material	UHMW WET (DRY)	HDPE WET (DRY)	NYLATRON WET (DRY)	STEEL (CS & SS) WET (DRY)	GLASS WET (DRY)	STEEL WET (DRY)	PLASTIC WET (DRY)	CARDBOARD WET (DRY)	ALUMINUM WET (DRY)
Polypropylene (S)	0.11 (0.13)	0.09 (0.11)	0.24 (0.25)	0.24 (0.25)	0.18 (0.19)	0.26 (0.32)	0.11 (0.17)	— (0.21)	0.40 (0.40)
Polypropylene (A)	NR	NR	0.29 (0.30)	0.29 (0.30)	0.18 (0.19)	0.26 (0.32)	0.11 (0.17)	— (0.21)	0.40 (0.40)
Polyethylene (S)	0.24 (0.32)	NR	0.14 (0.13)	0.14 (0.13)	0.08 (0.09)	0.10 (0.13)	0.08 (0.08)	— (0.15)	0.20 (0.24)
Acetal (S)	0.10 (0.10)	0.09 (0.08)	0.13 (0.15)	0.13 (0.15)	0.13 (0.14)	0.13 (0.13)	0.13 (0.16)	— (0.18)	0.33 (0.27)
EC Acetal (S)	0.10 (0.10)	0.09 (0.08)	0.13 (0.15)	0.13 (0.15)	0.13 (0.14)	0.19 (0.20)	0.13 (0.16)	— (0.18)	0.33 (0.27)
UV Resistant PP	0.11 (0.13)	0.09 (0.11)	0.24 (0.25)	0.24 (0.25)	0.18 (0.19)	0.26 (0.32)	0.11 (0.17)	— (0.21)	0.40 (0.40)

(S) = Smooth, Clean Conditions. (A) = Abrasive, Dirty Conditions. NR = Not Recommended.

a. Friction factor values are highly dependent on environmental conditions. The low value of the friction factor range is an experimentally derived friction factor for new belting on new wearstrip. This value should only be used in the cleanest environments or where water or other lubricating agents are present. Most applications should be adjusted based on the environmental conditions surrounding the conveyor.

b. Friction Factors for friction between product and belt only apply for Flat Top (Closed), Perforated Flat Top, Nub Top, Flush Grid and Raised Rib belts.

c. Polyethylene is not recommended for container handling.

Opening condition Note: Drive with soft start is recommended and is mandatory for frequent start/stops and start-up with full load.	SERVICE FACTORS						
	Standard straight belts				Micropitch with nosebar (**)		Radius belt curves with 90° (*)
	Standard head drive	Lower head drive	Pusher drive (uni- and bi-directional)	Center drive (uni- and bi-directional)	Head Side	Both ends	Standard head drive and lower head drive
Start-up prior to loading	1	1.1	1.4	1.2	1.6	2	1.6 (*)
Frequent start/stops during process (more than once per hour)	+ 0.2	+ 0.2	+ 0.2	+ 0.2	+ 0.2	+ 0.2	+ 0.2
Z-conveyors inclination <20° hold-down shoes only hold-down tabs	+ 0.2 + 0.3	+ 0.2 + 0.3	+ 0.2 + 0.3	+ 0.2 + 0.3	+ 0.2 + 0.3	+ 0.2 + 0.3	+ 0.2 + 0.3
inclination 20°-60° hold-down shoes only hold-down tabs	+ 0.4 + 0.6	+ 0.4 + 0.6	+ 0.4 + 0.6	+ 0.4 + 0.6	+ 0.4 + 0.6	+ 0.4 + 0.6	+ 0.4 + 0.6
inclination 60°-70° hold-down shoes only hold-down tabs	+ 1.1 + 1.4	+ 1.1 + 1.4	+ 1.1 + 1.4	+ 1.1 + 1.4	+ 1.1 + 1.4	+ 1.1 + 1.4	+ 1.1 + 1.4
inclination 70°-90° hold-down shoes only hold-down tabs	+ 1.8 + 2.2	+ 1.8 + 2.2	+ 1.8 + 2.2	+ 1.8 + 2.2	+ 1.8 + 2.2	+ 1.8 + 2.2	+ 1.8 + 2.2
Speed greater 30 m/min					+ 0.2	+ 0.2	+ 0.2

(*) The radius belt service factor depends on the angle of the curve.

(**) Z-conveyors with nosebar are not recommended.

Chemical Resistance

Factors like temperature, concentration of the driving forces, duration and mechanical load are important criterions for the examinations of chemical resistance. In the following table, you can see the materials resistance to different chemicals.*

-  Limited Resistance
-  Resistant
-  Not Resistance

*Resistance also dependent upon concentration, time, and temperature

AGENTS, CONCENTRATION: WEIGHT-%	MATERIAL	ABS	Acetal (copolymer)	Acetal (homopolymer)	Polyphenylene Ether	Nylon 6	PBT	PEEK	PET	Polycarbonate	Polyethylene	Polypropylene (homopolymere)	PPS	PPSU	PSU (polysulfone)	PTFE	PVDF
		Acetamide 50%	Resistant	Resistant	Limited Resistance	Resistant	Resistant	Resistant	Resistant	Resistant	Resistant	Resistant	Resistant	Resistant	Resistant	Resistant	Resistant
Acetic acid, aqueous solution 5%	Resistant	Resistant	Limited Resistance	Resistant	Resistant	Resistant	Resistant	Resistant	Resistant	Resistant	Resistant	Resistant	Resistant	Resistant	Resistant	Resistant	Resistant
Acetic acid, aqueous solution 10%	Resistant	Resistant	Limited Resistance	Resistant	Not Resistance	Limited Resistance	Resistant	Limited Resistance	Limited Resistance	Resistant	Resistant	Resistant	Resistant	Resistant	Resistant	Resistant	Resistant
Acetic acid, concentrated	Not Resistance	Limited Resistance	Not Resistance	Resistant	Not Resistance	Not Resistance	Not Resistance	Not Resistance	Not Resistance	Not Resistance	Not Resistance	Not Resistance	Not Resistance	Not Resistance	Not Resistance	Not Resistance	Not Resistance
Acetone	Not Resistance	Resistant	Resistant	Not Resistance	Limited Resistance	Not Resistance	Resistant	Resistant	Not Resistance	Not Resistance	Limited Resistance	Resistant	Resistant	Not Resistance	Not Resistance	Resistant	Limited Resistance
Ammonia solution 10%	Resistant	Resistant	Limited Resistance	Resistant	Resistant	Resistant	Resistant	Resistant	Resistant	Not Resistance	Resistant	Resistant	Resistant	Resistant	Limited Resistance	Resistant	Resistant
Anone	Resistant	Resistant	Resistant	Resistant	Resistant	Resistant	Resistant	Resistant	Resistant	Not Resistance	Limited Resistance	Resistant	Resistant	Resistant	Resistant	Resistant	Limited Resistance
Benzene	Not Resistance	Resistant	Resistant	Not Resistance	Resistant	Resistant	Limited Resistance	Resistant	Limited Resistance	Not Resistance	Limited Resistance	Limited Resistance	Limited Resistance	Limited Resistance	Limited Resistance	Not Resistance	Resistant
Benzine	Limited Resistance	Resistant	Resistant	Not Resistance	Resistant	Resistant	Resistant	Resistant	Resistant	Not Resistance	Limited Resistance	Limited Resistance	Limited Resistance	Limited Resistance	Limited Resistance	Resistant	Resistant
Bitumen	Resistant	Resistant	Resistant	Resistant	Resistant	Limited Resistance	Resistant	Resistant	Resistant	Not Resistance	Limited Resistance	Limited Resistance	Limited Resistance	Limited Resistance	Limited Resistance	Resistant	Resistant
Boric acid, aqueous solution 10%	Resistant	Not Resistance	Resistant	Resistant	Resistant	Resistant	Resistant	Resistant	Resistant	Resistant	Resistant	Resistant	Resistant	Resistant	Resistant	Resistant	Resistant
Butyl acetate	Not Resistance	Resistant	Resistant	Resistant	Resistant	Resistant	Resistant	Resistant	Resistant	Not Resistance	Limited Resistance	Limited Resistance	Resistant	Resistant	Limited Resistance	Resistant	Resistant
Calcium chloride, solution 10%	Resistant	Limited Resistance	Resistant	Resistant	Resistant	Resistant	Resistant	Resistant	Resistant	Resistant	Resistant	Resistant	Resistant	Resistant	Resistant	Resistant	Resistant
Carbon trachloride	Not Resistance	Resistant	Limited Resistance	Not Resistance	Resistant	Resistant	Resistant	Resistant	Resistant	Not Resistance	Not Resistance	Not Resistance	Resistant	Resistant	Limited Resistance	Resistant	Resistant
Chlorobenzene	Not Resistance	Resistant	Resistant	Resistant	Resistant	Resistant	Not Resistance	Resistant	Not Resistance	Not Resistance	Not Resistance	Not Resistance	Limited Resistance	Resistant	Resistant	Resistant	Resistant
Chloroform	Not Resistance	Not Resistance	Not Resistance	Not Resistance	Not Resistance	Not Resistance	Not Resistance	Not Resistance	Not Resistance	Not Resistance	Not Resistance	Limited Resistance	Limited Resistance	Resistant	Not Resistance	Resistant	Resistant
Citric acid, aqueous solution 10%	Resistant	Limited Resistance	Not Resistance	Resistant	Limited Resistance	Resistant	Resistant	Resistant	Resistant	Resistant	Resistant	Resistant	Resistant	Resistant	Resistant	Resistant	Resistant
Clophene A60, 50%	Resistant	Resistant	Limited Resistance	Resistant	Resistant	Resistant	Resistant	Resistant	Resistant	Resistant	Resistant	Resistant	Resistant	Resistant	Resistant	Resistant	Resistant
Cupric sulphate 10%	Resistant	Resistant	Not Resistance	Resistant	Resistant	Resistant	Resistant	Resistant	Resistant	Resistant	Resistant	Resistant	Resistant	Resistant	Resistant	Resistant	Resistant
Cyclohexane	Resistant	Resistant	Resistant	Resistant	Resistant	Resistant	Resistant	Resistant	Resistant	Not Resistance	Not Resistance	Resistant	Resistant	Resistant	Resistant	Resistant	Resistant
Cyclohexanone	Not Resistance	Resistant	Resistant	Resistant	Resistant	Resistant	Resistant	Resistant	Resistant	Limited Resistance	Limited Resistance	Resistant	Resistant	Resistant	Resistant	Resistant	Limited Resistance
Decalin	Not Resistance	Resistant	Resistant	Resistant	Resistant	Resistant	Resistant	Resistant	Resistant	Limited Resistance	Limited Resistance	Resistant	Resistant	Resistant	Resistant	Resistant	Resistant
Diesel Oil	Resistant	Resistant	Resistant	Resistant	Resistant	Resistant	Resistant	Resistant	Resistant	Limited Resistance	Limited Resistance	Limited Resistance	Resistant	Resistant	Resistant	Resistant	Resistant
Dimethyl formamide	Not Resistance	Resistant	Not Resistance	Resistant	Resistant	Resistant	Resistant	Resistant	Resistant	Not Resistance	Resistant	Resistant	Resistant	Resistant	Resistant	Resistant	Resistant
Diocetyl phthalate	Resistant	Resistant	Resistant	Resistant	Resistant	Resistant	Resistant	Resistant	Resistant	Limited Resistance	Resistant	Resistant	Limited Resistance	Resistant	Resistant	Resistant	Resistant

-  Limited Resistance
-  Resistant
-  Not Resistance

*Resistance also dependent upon concentration, time, and temperature

AGENTS, CONCENTRATION: WEIGHT-%	MATERIAL	ABS	Acetal (copolymer)	Acetal (homopolymer)	Polyphenylene Ether	Nylon 6	PBT	PEEK	PET	Polycarbonate	Polyethylene	Polypropylene (homopolymere)	PPS	PPSU	PSU (polysulfone)	PTFE	PVDF
Dioxane			○	□	○	□	○		○	▲	○	□	□			□	□
Edible fats, Edible oils			□	□	□	□				□	□	□	□			□	□
Ethanol 96%		□	□	□	□					○	□	□	□	□		□	□
Ethyl acetate			○	□	□		○		○	▲	□	□			▲	□	□
Ethyl ether			□			□	□		□	▲	□	□		□	□	□	□
Ethylene chloride		▲	▲	▲			▲			▲	○						
Formaldehyde, aqueous solution 30%		□	□	▲	□	□		□		□	□	□	□		□	□	□
Formamide				○		□					○						
Formic acid, aqueous solution 10%		□	□	▲		▲				□	□	□	□			□	□
Freon, Frigen, Liquid		○		□	□			▲		▲	○	▲	□		□	□	□
Fruit juices		□	□		□	□				▲	□	□				□	□
Glycerine		□	□	□	□	□				○	□	□				□	□
Glykol		□	□	□	□	□				□	□	□	□			□	□
Glysantin, aqueous solution 40%										□	□	□				□	□
Heating oil		□	□	□	□	□				○	□	○	□			□	□
Heptane, Hexane		□	□	□	□	□					▲	□			□	□	□
Hydrochloric acid, aqueous solution 2%		□	▲	▲		▲				□	□	□	○	□	□	□	□
Hydrochloric acid, aqueous solution 36%		□	▲	▲		▲	▲		▲	□	□	□		○		□	□
Hydrofluoric acid, 40%		○	▲	▲	□	▲	▲		▲	○	□	□			○	□	□
Hydrogen peroxide, aqueous solution 0.5%		□	○	□		▲	□		□	□	□	□	□	□	□	□	□
Hydrogen peroxide, aqueous solution 30%		□	▲	□		▲	▲		▲	□	□	□		○	□	□	□
Hydrogen sulphide saturated		▲		▲	□	□		□		□	□	□				□	□
Ink		□			□	□	□		□	□	□	□				□	□
Iodine solution, alcohol solution		□	○	□		▲				□	○	□			□	□	□
Iso-octane		□		□	□	□				□	□	□			□	□	□
Isopropanol		○	□	□	□	□	□		□	○	□	□	□	□	○	□	□
Lactic acid, aqueous solution 10%		□	□	○	□	□		□		□	□	□				□	□
Lactic acid, aqueous solution 90%		▲	□	▲	▲	▲				□	□	□				□	□
Linseed oil		□	□	□	□	□	□			□	□	□				□	□
Methanol		○	□	□	□	□	□			▲	□	□		○	□	□	□

-  Limited Resistance
 -  Resistant
 -  Not Resistance
- *Resistance also dependent upon concentration, time, and temperature

AGENTS, CONCENTRATION: WEIGHT-%	MATERIAL															
	ABS	Acetal (copolymer)	Acetal (homopolymer)	Polyphenylene Ether	Nylon 6	PBT	PEEK	PET	Polycarbonate	Polyethylene	Polypropylene (homopolymere)	PPS	PPSU	PSU (polysulfone)	PTFE	PVDF
Sodium thiosulphate 10%	Resistant	Resistant	Resistant	Resistant	Resistant	Resistant	Resistant	Resistant	Resistant	Resistant	Resistant	Resistant	Resistant	Resistant	Resistant	Resistant
Styrene	Resistant	Resistant	Resistant	Not Resistance	Resistant	Resistant	Resistant	Resistant	Not Resistance	Limited Resistance	Limited Resistance	Resistant	Resistant	Resistant	Resistant	Resistant
Sulphur dioxide	Not Resistance	Resistant	Resistant	Resistant	Resistant	Resistant	Resistant	Resistant	Not Resistance	Limited Resistance	Resistant	Resistant	Resistant	Resistant	Resistant	Resistant
Sulphuric acid, aqueous solution 2%	Resistant	Not Resistance	Resistant	Resistant	Not Resistance	Resistant	Resistant	Resistant	Resistant	Resistant	Resistant	Resistant	Resistant	Resistant	Resistant	Resistant
Sulphuric acid, concentrated 98%	Not Resistance	Not Resistance	Not Resistance	Not Resistance	Not Resistance	Not Resistance	Not Resistance	Not Resistance	Not Resistance	Limited Resistance	Resistant	Resistant	Resistant	Not Resistance	Resistant	Limited Resistance
Tar	Resistant	Resistant	Resistant	Resistant	Limited Resistance	Resistant	Resistant	Resistant	Resistant	Resistant	Resistant	Resistant	Resistant	Resistant	Resistant	Resistant
Tartaric acid	Resistant	Limited Resistance	Limited Resistance	Resistant	Resistant	Resistant	Resistant	Resistant	Resistant	Resistant	Resistant	Resistant	Resistant	Resistant	Resistant	Resistant
Tetrahydrofurane	Not Resistance	Limited Resistance	Not Resistance	Resistant	Resistant	Not Resistance	Resistant	Not Resistance	Not Resistance	Limited Resistance	Limited Resistance	Resistant	Resistant	Resistant	Resistant	Resistant
Tetralin	Not Resistance	Resistant	Resistant	Resistant	Resistant	Resistant	Resistant	Resistant	Not Resistance	Limited Resistance	Limited Resistance	Not Resistance	Resistant	Resistant	Resistant	Resistant
Toluene	Not Resistance	Resistant	Resistant	Resistant	Resistant	Limited Resistance	Resistant	Limited Resistance	Not Resistance	Limited Resistance	Limited Resistance	Limited Resistance	Limited Resistance	Not Resistance	Resistant	Resistant
Trransformer oil	Resistant	Resistant	Resistant	Resistant	Resistant	Resistant	Resistant	Resistant	Resistant	Limited Resistance	Limited Resistance	Resistant	Resistant	Resistant	Resistant	Resistant
Trichlorethylene	Not Resistance	Not Resistance	Not Resistance	Not Resistance	Limited Resistance	Not Resistance	Resistant	Not Resistance	Not Resistance	Not Resistance	Limited Resistance	Limited Resistance	Resistant	Resistant	Resistant	Resistant
Triethanolamine	Resistant	Resistant	Not Resistance	Resistant	Resistant	Resistant	Resistant	Not Resistance	Resistant	Resistant	Resistant	Limited Resistance	Resistant	Resistant	Resistant	Resistant
Trion B, aqueous solution 10%	Resistant	Resistant	Resistant	Resistant	Resistant	Resistant	Resistant	Resistant	Resistant	Resistant	Resistant	Resistant	Resistant	Resistant	Resistant	Resistant
Urea, aqueous solution	Resistant	Resistant	Resistant	Resistant	Resistant	Resistant	Resistant	Resistant	Resistant	Resistant	Resistant	Resistant	Resistant	Resistant	Resistant	Resistant
Vaseline	Resistant	Resistant	Resistant	Resistant	Resistant	Resistant	Resistant	Resistant	Resistant	Limited Resistance	Resistant	Resistant	Resistant	Resistant	Resistant	Resistant
Water, cold	Resistant	Resistant	Resistant	Resistant	Resistant	Resistant	Resistant	Resistant	Resistant	Resistant	Resistant	Resistant	Resistant	Resistant	Resistant	Resistant
Water, warm	Resistant	Limited Resistance	Not Resistance	Resistant	Limited Resistance	Not Resistance	Resistant	Not Resistance	Limited Resistance	Resistant	Resistant	Resistant	Limited Resistance	Limited Resistance	Resistant	Resistant
Wax, molten	Resistant	Resistant	Resistant	Resistant	Resistant	Resistant	Resistant	Resistant	Limited Resistance	Limited Resistance	Resistant	Resistant	Resistant	Resistant	Resistant	Resistant
Wine, Brandy	Resistant	Resistant	Resistant	Resistant	Resistant	Resistant	Resistant	Resistant	Resistant	Resistant	Resistant	Resistant	Resistant	Resistant	Resistant	Resistant
Xylene	Not Resistance	Resistant	Resistant	Not Resistance	Resistant	Limited Resistance	Resistant	Limited Resistance	Not Resistance	Not Resistance	Not Resistance	Resistant	Resistant	Resistant	Not Resistance	Resistant
Zinc chloride, aqueous solution 10%	Resistant	Not Resistance	Resistant	Resistant	Limited Resistance	Resistant	Resistant	Resistant	Resistant	Resistant	Resistant	Resistant	Resistant	Resistant	Resistant	Resistant



MODUTECH®

- DECLARATION OF COMPLIANCE -

Modutech Konveyör Bant Sistemleri San. ve Tic. A.S., Kemalpaşa OSB Mah. No: 228 Kuyucak Yolu Kumeevleri / Izmir, Turkey, here by declares under its exclusive responsibility that the Modular Belt (PP) Conforms with the Food Regulation:

FDA

according to the CFR code
code of Federal Regulations

Title 21 § 177.520

Granules and additives used to manufacture the modular belts are selected exclusively among those listed by FDA standard Specifications 3.1 olefin copolymers for use in articles that contact food except for articles used for packing and holding food during cooking.
This attest was issued on the basis of the accredited NSF laboratory test with:

Project no: 9896049,

Date of Report: January 9th, 2015



Modutech Konveyör Bant Sistemleri San. ve Tic. A.S.
Ankara Asfaltı 25.km Köşülcükler Mevkii
Kuyucak Kemalpaşa / Izmir - TURKEY
Phone : +90 232 877 00 22 (pbx)
Fax: +90 232 877 01 11
Mail: info@modutech.com.tr
www.modutech.com.tr

İbrahim BAYIR
Modutech Quality Manager



MODUTECH®

- DECLARATION OF COMPLIANCE -

Modutech Konveyör Bant Sistemleri San. ve Tic. A.S., Kemalpaşa OSB Mah. No: 228 Kuyucak Yolu Kumeevleri / Izmir, Turkey, here by declares under its exclusive responsibility that the **MODULAR BELT POLYPROPYLENE PLASTIC (PP) RAW MATERIAL**

Conforms with the Food Regulations with reference to
COMMISSION REGULATION EU NO 10/2011 of 14 January 2011 and amendments

The belt is suitable to come into contact with any aqueous, acid, oily and fatty food listed in the Regulation EU 10/2011 and amendments.

As prescribed by Commission Regulation EU 10/2011 – Annex III and Annex V, MODUTECH declares that:

All materials used to produce this belt comply with the applicable law.

The overall migration of the authorised substances, measured using the prescribed extracting substances (simulants) is lower than the maximum limit allowed:

Overall migration with simulant A – ethanol 10%	< 10 mg / dm ²
Overall migration with simulant B – acetic acid 3%	< 10 mg / dm ²
Overall migration with simulant – ethanol 95%	< 10 mg / dm ²
Overall migration with simulant – isooctane	< 10 mg / dm ²
Overall migration with simulant E – MPPG (tenax)	< 10 mg / dm ²

Tests have been carried out for a period of 2 hours at 70°C.
The limit of detection is 3 mg / dm².

The soluble heavy metals in aqueous test is lower than the maximum limit allowed :

Specific migration of Barium	< 1,00 mg / kg
Specific migration of Cobalt	< 0,05 mg / kg
Specific migration of Copper	< 5,00 mg / kg
Specific migration of Iron	< 48,00 mg / kg
Specific migration of Lithium	< 0,60 mg / kg
Specific migration of Manganese	< 0,60 mg / kg
Specific migration of Zinc	< 25,00 mg / kg

The information herein contained represents an extract from an analysis certification issued by a Accredited IAS laboratory test with: Report no TR1130211 Dated 07.06.2017



Modutech Konveyör Bant Sistemleri San. ve Tic. A.S.
Ankara Asfaltı 25.km Köşülcükler Mevkii
Kuyucak Kemalpaşa / Izmir - TURKEY
Phone : +90 232 877 00 22 (pbx)
Fax: +90 232 877 01 11
Mail: info@modutech.com.tr
www.modutech.com.tr

İbrahim BAYIR
Modutech Quality Manager

Our Declaration of Compliance

Modutech offers you wide range of modular belts with FDA - EU certificates.

