

SYSTEM PLAST™



Conveyor Components, Chains and Belts Catalog Issue 6.2

A Regal Brand

REGAL

Check out our most popular products online:
www.SystemPlastSmartGuide.com



SYSTEM PLAST™

System Plast™ is the one source for Valu Guide® components, System Plast conveyor chains and belts, plastic materials and custom machined products from Nolu Plastics.

With years in the industry, System Plast is committed to a product development process that continues to deliver innovative solutions. We tackle the tough problems like noise reduction, hygiene, and increased productivity with solutions such as Nolu-S material, SaniStar levelers, and SpeedSet brackets.

In today's competitive environment, components that stand up to the rigors of high volume production are an absolute must. From guide rails and wear surfaces to conveyor chains, sprockets, mounted bearings and leveling pads, System Plast products are comprehensive, industry proven and available to you from one source.

Keep your equipment – and your business – moving forward

The whole world is on the move today. Everything from people and products to ideas and information That means business has to be on the move, as well. Power Transmission Solutions™ can help. We keep products – and businesses – moving forward. Whether it's helping to make sure that packages arrive on time, roads are built, energy is produced, food and beverages are processed, or luggage arrives at airport baggage areas, our products and solutions help make the world go.



VALU
GUIDE®

NOLU
PLASTICS



Conveyor Chains **2**

- Steel Flat Top Chains
- Side Flexing Chains
- Plate Top Chains
- Thermoplastic Flat Top Chains
- Multi-flex Chains
- Crate Conveyor Chains
- Straight Running Chains
- Gripper Chains
- Flat Top Belts



Sprockets, Wear Strips & Conveyor Chain Guides . . **101**

- Sprockets and Idlers
- Transfer Plates
- ValuFlex™
- ValuTrac™
- Modular Guides
- Wear Strips
- Magnetic Corner Tracks
- Return Rollers
- Roller Chain Guides



Guide Rails and Hardware **197**

- Guide Rails
- Lane Dividers
- Rail Clamps
- Chain Guides
- Wear Beds
- Rail Splicing
- PolyGlide Rails
- Guide Rail Benders
- Rail Clips



UHMW Covers & Aluminum Rails **241**

- Bar Caps
- Bar Covers
- Round Bars
- PET Neck Guides
- Tube Covers
- Flight Edging
- J-Legs
- Aluminum Rails
- Hanger Bearings



Bead and Roller Guides **265**

- SpeedRail™
- Flexible Roller Module
- Heavy Duty Bead-Wall™
- SpeedRoll™
- Lane Dividers
- Roller Combiner
- BeadRail™
- BeadWall™
- Custom Parts



Brackets & Positioning Components **289**

- Guide Rail Brackets: Fixed and Adjustable
- Spacers
- Drip Pan Holders
- Adjusting Rods
- Knobs
- Cross Blocks
- SpeedSet™ Brackets
- Protective Caps
- Accessory Holders



Machine & Equipment Components **341**

- Threaded Tube Ends
- Support Levelers
- Bipods, Tripods
- SaniStar Levelers
- Vibration Pads
- Ratchet Handles
- Articulating Levelers
- Post Caps
- Enclosure Handles and Hinges



Roller Products **383**

- Roll-Tech
- Sleeve Bearings
- Stub Shafts
- Return Rollers
- Customized Rollers
- Adapters
- Off-The-Shelf Rollers
- Roller End Bearings
- Ball Bearings



Machined Plastics, Technical Information. **415**

- Premium Plastic Fabrication
- Chemical Resistance
- Engineered Plastic Materials
- Index
- Material Physical Properties

Conveyor Chain Selection

812, 815

Straight Running



page **8**

815L

Straight Running



page **8**

881

Side Flexing



page **10**

8810

Side Flexing



page **10**

881 TAB

Side Flexing



page **12**

8810 TAB

Side Flexing



page **12**

881M, 881MO

Side Flexing



page **14**

L881MO

Side Flexing



page **14**

820

Straight Running



page **16**

831

Straight Running



page **18**

828

Straight Running



page **20**

821

Straight Running



page **22**

878 TAB

Side Flexing



page **24**

879, 880

Side Flexing



page **26**

879/880 TAB

Side Flexing



page **28**

879M, 880M

Side Flexing



page **30**

882

Side Flexing



page **32**

882 TAB

Side Flexing



page **34**

Conveyor Chain Selection

831 VG
Straight Running



page **36**

878 TAB VG
Side Flexing



page **38**

879 TAB VG
Side Flexing



page **40**

882 TAB VG
Side Flexing



page **42**

878 TAB GS
Side Flexing



page **44**

1873 GS
Side Flexing



page **46**

843
Straight Running



page **48**

863
Straight Running



page **49**

1843
Side Flexing



page **50**

1863
Side Flexing



page **51**

1873
Side Flexing



page **52**

1700
Multiflex Chains



page **54**

1702
Multiflex Chains



page **54**

1701 TAB
Multiflex Chains



page **56**

1701 TAB OP
Multiflex Chains



page **56**

CC 600
CC 600 TAB
Crate Conveyor Chains



page **58**

CC 1400
CC 1400 TAB
CC 1431
Crate Conveyor Chains



page **59**

Conveyor Chain Selection

LBP 821
Straight Running
page **60**



LBP 8257
Straight Running
page **62**



LBP 831
Straight Running
page **64**



LBP 2120
Straight Running
page **80**



LBP 2251
Straight Running
page **94**

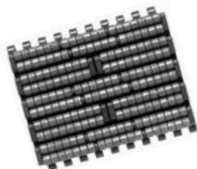

LBP 882 TAB
Side Flexing
page **66**



LBP 882 M
Side Flexing
page **70**



LBP 878 TAB
Side Flexing
page **72**



2121
Straight Running
page **76**



2121 FT
Straight Running
page **78**

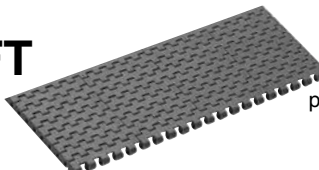

2252
Straight Running
page **88**

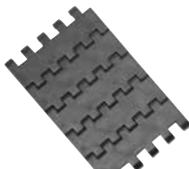

2252 FT
Straight Running
page **90**

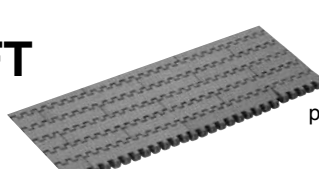

2252 PT
Straight Running
page **92**

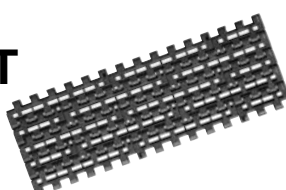

2250 TAB
Side Flexing
page **82**



2250M
Side Flexing
page **84**



2260M
Side Flexing
page **86**



2251M
Side Flexing
page **98**



2251 TAB
Side Flexing
page **96**



Catenary (chain sag)

Catenary or chain sag is an inherent feature in chain conveyors which provides a mechanical balance between absorbed and unabsorbed chain tension. The catenary area of a conveyor must be properly designed to accommodate catenary sag for a given chain. Catenary performs two valuable functions. First, it balances any loads not absorbed by sprocket teeth. This balance between unabsorbed tension and catenary weight should occur about 150° around the drive sprocket. Second, it provides an area in the conveyor to easily remove links as the chain stretches. It has to be accessible to the maintenance personnel. Catenary will fluctuate during normal operation due to chordal action. See design details above.

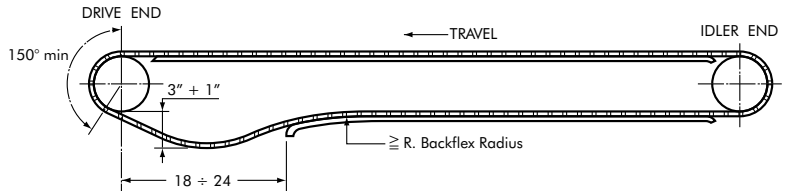

Sprocket / Wear Strip Positioning

Conveyor chain is subject to chordal action (rising and falling) as it enters drive sprocket engagement and when it leaves a tail sprocket or idler wheel. Sprockets must, therefore, be mounted such that the sprocket's highest point is no higher than the carrying support wear strip. This contains the chain's tendency to rise out of the carrying way. The distance from the end of the wear strip to the center line of the sprocket shaft should equal dimension "B" in the accompanying drawing and tables. This prevents interference with the free movement of the chain as it engages the sprocket. Leading edges of the wear strips should be beveled at this entry point

The minimum number of teeth for chains 1873 and 1874 sprockets is 15. Otherwise the hold down tab touches the sprocket hub.

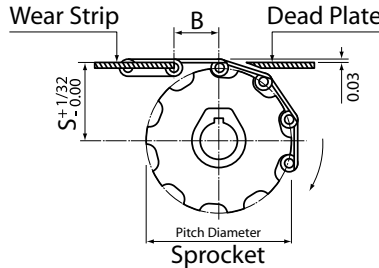

$$S = \left(\frac{\text{Pitch Diameter}}{2} \right) + C$$

"B" Values	Chain Series Numbers
1"	843, 1843, 844
1-1/2"	815, 820, 821, 831, 963, 880, 881, 882, 879, 1873, 1874, 863, 802, 805
50mm	1700, 1701, 1702, 7000, 7005, 7001

"C" Values	Chain Series Numbers
3/32"	831
7/64"	879
1/8"	815, 820, 821, 881, 805, 800, 8810, 881M, 881MO
9/64"	880, 828, 878
3/16"	882
1/4"	843
9/32"	1843
7/16"	863, 963, 864
15/32"	1863, 1873, 1874
15/32"	7000, 7001, 7005, 1700, 1701, 1702

Idler Wheel Positioning

Idler wheels may be used in place of tail sprockets on one-piece chain conveyors. Idler wheels are not recommended for use with base roller chains. Constructed of engineered plastic, idler wheels are self-lubricating and provide resistance to most chemicals and corrosive conditions. To replace a tail sprocket with an idler wheel, two set collars can be employed to position the wheel and hold it slightly below the top of the wear strips as shown at right.

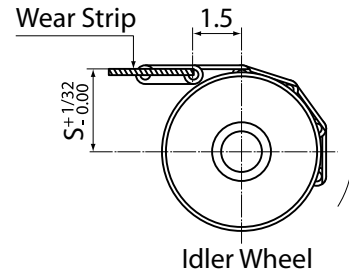

Idler Wheels	S
Z 15	1.90"
Z 17	2.22"
Z 19	2.47"
Z 21	2.70"
Z 23	2.94"
Z 25	3.17"

Entry Radius

Allocation for sufficient entry radius to the return section of the conveyor must be provided in order to allow the chain to feed cleanly onto the return ways. The curve radius provided with the re-entry shoe should be at least that shown in the table.

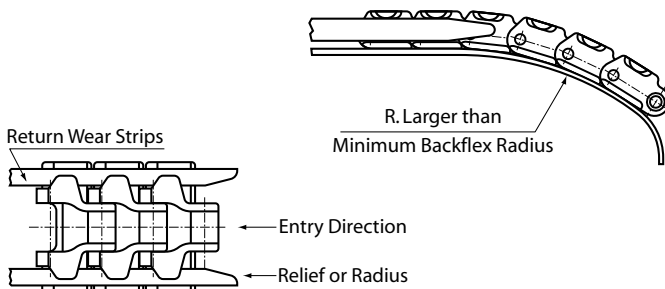

Chain Series Numbers	Min. Backflex Radius	Chain Series Numbers	Min. Backflex Radius
815	6"	881, 8810	2"
805	6"	LBP 882	10"
820, 831	2"	882	2"
821	2"	1873	12"
843	4"	1874	10"
863, 963	5"	1700, 7000	2"
LBP 821	10"	1843	2"
831, 879	2"		

TAB chains with hold-down tabs should be guided onto return wear strips with a guide shoe or comparable support. Round corners should be provided at the entry of the return wear strips to facilitate a smooth entry of the TAB shoes.

Steel Chain Materials

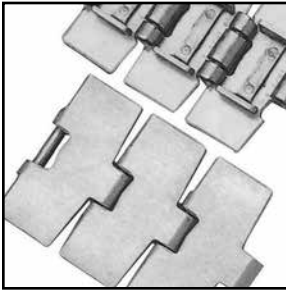

Material name: **C45 hardened carbon steel**
 This carbon steel material allows a higher yield load capability than stainless steel but is not corrosion resistant. The hardened plate material provides for a uniform hardness of 44 HRC.

- Features:**
- Surface hardness: 44 HRC

- Benefits:**
- High mechanical strength
 - High abrasion resistance

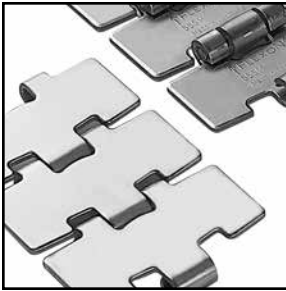

Material name: **Standard 430 grade ferritic stainless steel**
 AISI 430 Stainless steel material with good mechanical characteristics and limited corrosion resistance. An economical option for many conveying applications. Lower load and lower wear resistance capability than our other stainless steel materials.

- Features:**
- Rust resistant stainless steel

- Benefits:**
- Economic stainless steel option

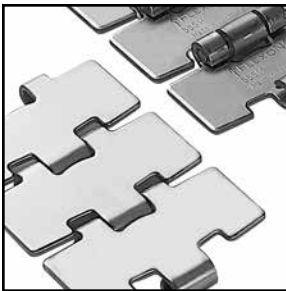

Material name: **special 400 series Extra Plus high performance stainless steel**
 High performance stainless steel, specially developed for high speed and heavy duty applications. Offers excellent corrosion resistance and the highest surface hardness.

- Features:**
- Surface hardness of HRC 26-30
 - High corrosion and wear resistance
 - Extremely flat and best surface finish
 - Highest ultimate yield loading capability

- Benefits:**
- Typically used in pressureless combiners and excessively long conveyors.
 - Improved product stability, especially for P.E.T.

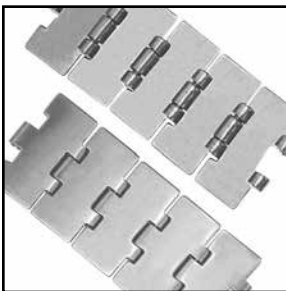

Material name: **304 grade Austenitic stainless Steel**
 AISI 304 Austenitic stainless steel which offers exceptionally high corrosion and acid resistance properties

- Features:**
- Non magnetic stainless steel
 - 18% chrome and 8% nickel

- Benefits:**
- High corrosion and acid resistance material

STEEL CHAIN APPLICATION TEMPERATURES

Material	Symbol	Minimum Temp. °F	Max. Temp. °F Dry Environment
Carbon Steel	C45	- 94°	+ 356°
Ferritic Stainless Steel	Standard	- 22°	+ 752°
Extra Plus Stainless Steel	Extra Plus	- 22°	+ 752°
Austenitic Stainless Steel	Austic	- 22°	+ 752°

Other materials are available. See the complete System Plast conveyor chain catalog for details.

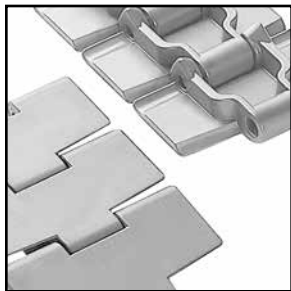

Material name: **LF, LFG, LFW Low Friction Acetal Resin**
 It is identical to the delrin acetal material and offers an improved coefficient of friction. This material is suitable for use in high speed applications.

Operating temperatures:
 dry: - 40°F to + 176°F
 wet: 32°F to +149°F
Color: Light Brown, Dark Grey or White
 This material is FDA (Food and Drug Administration) approved for direct contact with food.

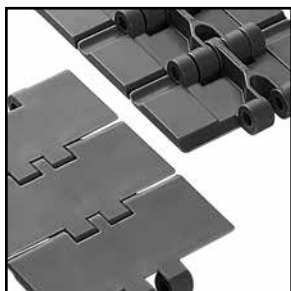

Material name: **XPG Extra Performance**
 Extra performance acetal with a very low coefficient of friction compared to other LF materials. Suitable for high speed applications and reduced lubrication. Equivalent to other manufacturer's high performance materials.

Operating temperatures:
 dry: - 40°F to + 176°F
 wet: 32°F to +149°F
Color: Brown
 This material is FDA (Food and Drug Administration) approved for direct contact with food.

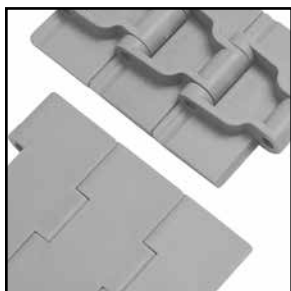

Material name: **NG New Generation**
 Extra performance PBT with the lowest coefficient of friction in our range, resulting in medium strength and optimum wear resistance, along with reduced plate wear and reduced pitch elongation. Suitable for dry running applications. NG material should not be exposed to high humidity levels or wet conditions at temperatures above 140°F. Available in flat top chain exclusively from System Plast .

Operating temperatures:
 up to 248°F
Color: Green or Dark Grey

PLASTIC CHAIN APPLICATION TEMPERATURES

Material	Symbol	Minimum Temp. °F	Max. Temp. °F Dry Environment
Acetal Resin	D, W	- 40°	+ 176°
Low Friction Acetal Resin	LF, LFW	- 40°	+ 176°
Extra Performance	XPG	- 40°	+ 176°
New Generation	NG	- 40°	+ 248°

Other materials are available. See the complete System Plast conveyor chain catalog for details.

Straight Running Steel Chains

812, 815

Straight Running Chains, Single Hinge

These chains feature high wear resistance, durability, and an excellent surface finish.

Standard Length: 10ft.
Pitches: 80

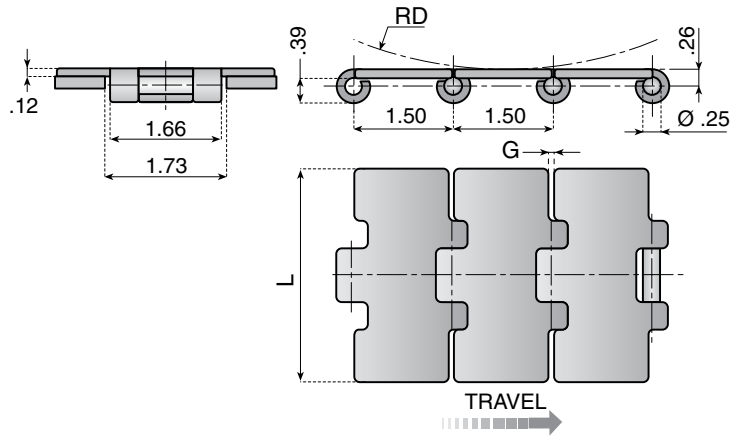
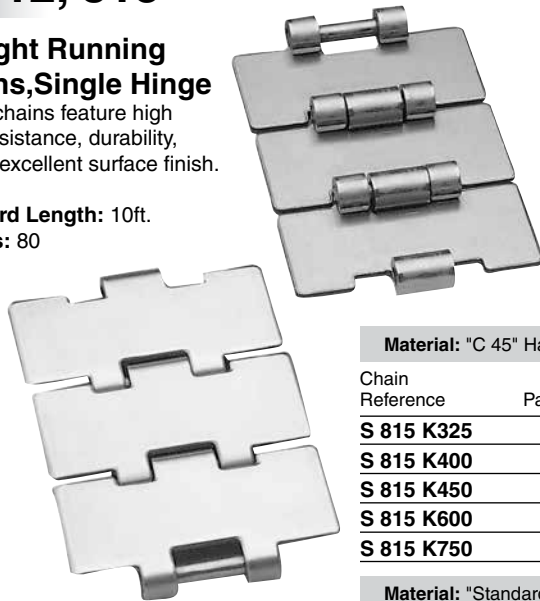

Material: "C 45" Hardened carbon steel.

Chain Reference	Part Number	Yield Point (lbs.)	Surface Finish (micro inches)	Flatness (max)	L (width)	G	RD	Weight (lbs. per ft.)
S 815 K325	10302	2696	-	-	3-1/4	.07	5.91	1.74
S 815 K400	10304	2696	-	-	4	.07	5.91	2.01
S 815 K450	10305	2696	-	-	4-1/2	.07	5.91	2.21
S 815 K600	10306	2696	-	-	6	.07	5.91	2.81
S 815 K750	10307	2696	-	-	7-1/2	.07	5.91	3.42

Material: "Standard" 430 grade ferritic stainless steel.

Chain Reference	Part Number	Yield Point (lbs.)	Surface Finish (micro inches)	Flatness (max)	L (width)	G	RD	Weight (lbs. per ft.)
SSL 812 K325	10001L	1215	24	.004	3-1/4	.06	5.91	1.74
SSR 812 K325	10007	1215	24	.006	3-1/4	.11	2.95	1.68
SS 812 K400	10003	1215	24	.008	4	.07	5.91	2.01
SS 812 K450	10004	1215	24	.008	4-1/2	.07	5.91	2.21
SS 812 K600	10005	1215	24	.012	6	.07	5.91	2.81
SS 812 K750	10006	1215	24	.012	7-1/2	.07	5.91	3.42

Material: Special 400 series "Extra Plus" high performance stainless steel.

Chain Reference	Part Number	Yield Point (lbs.)	Surface Finish (micro inches)	Flatness (max)	L (width)	G	RD	Weight (lbs. per ft.)
SSEL 815 K325	10009L	1911	12	.004	3-1/4	.06	5.91	1.74
SSE 815 K400	10011	1911	12	.008	4	.07	5.91	2.01
SSE 815 K450	10012	1911	12	.008	4-1/2	.07	5.91	2.21
SSE 815 K600	10013	1911	12	.012	6	.07	5.91	2.81
SSE 815 K750	10014	1911	12	.012	7-1/2	.07	5.91	3.42

Material: Special 400 series "Extra Plus" high performance stainless steel. Pins are made from vacuum hardened stainless steel.

Chain Reference	Part Number	Yield Point (lbs.)	Surface Finish (micro inches)	Flatness (max)	L (width)	G	RD	Weight (lbs. per ft.)
SSEL 815 K325 HB	10036L	1911	12	.02	3-1/4	.06	5.91	1.74

Material: 304 grade austenitic stainless steel.

Chain Reference	Part Number	Yield Point (lbs.)	Surface Finish (micro inches)	Flatness (max)	L (width)	G	RD	Weight (lbs. per ft.)
SSA 815 K325	10016	1191	12	.006	3-1/4	.07	5.91	1.74
SSA 815 K400	10018	1191	12	.008	4	.07	5.91	2.01
SSA 815 K450	10019	1191	12	.008	4-1/2	.07	5.91	2.21
SSA 815 K600	10020	1191	12	.012	6	.07	5.91	2.81
SSA 815 K750	10021	1191	12	.012	7-1/2	.07	5.91	3.42

815L (Speed-Line)

Straight Running Chains, Single Hinge

Speed-Line chains feature specially designed plates and hinges that allow for smooth transfers. High speed applications or pressureless combiner areas are ideal for this type of chain. Other features include minimal gaps and an excellent surface finish.

Standard Length: 10ft.
Pitches: 80

Material: Special 400 series "Extra Plus" high performance stainless steel.

Chain Reference	Part Number	Yield Point (lbs.)	Surface Finish (micro inches)	Flatness (max)	Polished Hinges	L (width)	RD	Weight (lbs. per ft.)
SPSL 815 K325	10085L	1911	8	.004	yes	3-1/4	6	1.74

Material: Special 400 series "Extra Plus" high performance stainless steel. Pins are made from vacuum hardened stainless steel.

Chain Reference	Part Number	Yield Point (lbs.)	Surface Finish (micro inches)	Flatness (max)	Polished Hinges	L (width)	RD	Weight (lbs. per ft.)
SPSL 815 K325 HB	10095L	1911	8	.004	yes	3-1/4	6	1.74

Straight Running Steel Chains

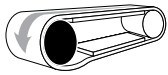

Drive Sprocket Options for 812, 815 Chains



Machined Split



Molded Split

Shaft Sized Bore Dia.	Teeth or Equivalent	Part Number	Part Number
.71*	19	12905	-
1	19	12529S	-
1-1/4	19	12530S	-
1-7/16	19	12538S	-
1-1/2	19	12539S	-
.71*	21	12906	-
1	21	12540S	32053
1-1/4	21	12541S	32054
1-7/16	21	12542S	32055
1-1/2	21	12543S	32056
.71*	23	12907	-
1	23	12544S	32099
1-1/4	23	12545S	32100
1-7/16	23	12546S	32101
1-1/2	23	12547S	32102
.71*	25	12908	-
1	25	12548S	32065
1-1/4	25	12549S	32066
1-7/16	25	12550S	32067
1-1/2	25	12551S	32068
.71*	27	121199	-
1	27	121200S	-
1-1/4	27	121201S	-
1-7/16	27	121202S	-
1-1/2	27	121203S	-

*Plain bore pilot hole. Not sized to a shaft.

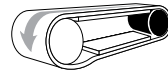

Idler Options for 812, 815 Chains



Machined Split



Molded Split



Low-Friction Molded



Molded Split

Part Number	Part Number	Part Number	Part Number
-	-	-	-
121239S	-	-	-
121240S	-	-	-
121241S	-	-	-
121242S	-	-	-
-	-	-	-
121243S	321080	32866	32077B
121244S	321081	32867	32078B
121245S	321082	32868	32079B
121246S	321083	32869	32080B
-	-	-	-
121247S	321085	32874	-
121248S	321086	32875	-
121249S	321087	32876	-
121250S	321088	32877	-
-	-	-	-
121251S	321090	32870	32081B
121252S	321091	32871	32082B
121253S	321092	32872	32083B
121254S	321093	32873	32084B
-	-	-	-
121255S	-	-	-
121256S	-	-	-
121257S	-	-	-
121258S	-	-	-

See all sprockets and idlers on pages 101-125

Side Flexing Steel Chains

881

Side Flexing Chains, Bevel Guides

These chains feature high wear resistance, exceptional durability and hardness, high tensile strength, and an excellent surface finish.

Standard Length: 10ft.
Pitches: 80

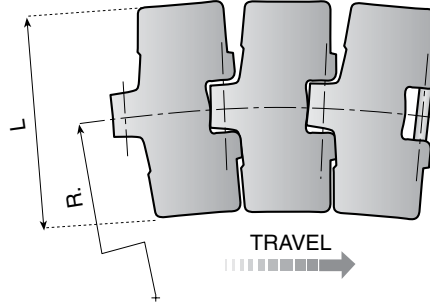
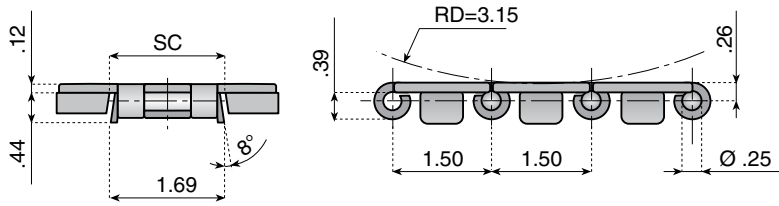

Material: 304 grade austenitic stainless steel.

Chain Reference	Part Number	Yield Point (lbs.)	Surface Finish (micro inches)	L (width)	R Min.	SC Straight	SC Curved	Weight (lbs. per ft.)
SSA 881 K325	10107	1011	12	3-1/4	20	1.75	1.63	2.01
SSA 881 K450	10108	1011	12	4-1/2	20	1.75	1.63	2.48
SSA 881 K750	10109	1011	12	7-1/2	20	1.75	1.63	3.69



881O

Side Flexing Chains, Bevel Guides

881O offers a further improvement to the standard chains series 881. This chain has a smaller gap between plates and therefore creates a larger surface area for conveying purposes and improved product stability.

Standard Length: 10ft.
Pitches: 80

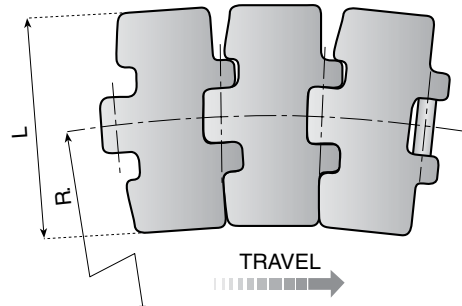
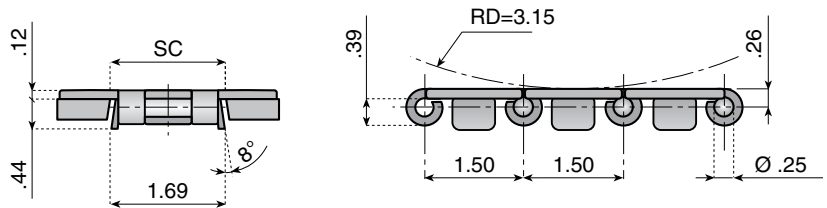

Material: Special 400 series "Extra Plus" high performance stainless steel.

Chain Reference	Part Number	Yield Point (lbs.)	Surface Finish (micro inches)	L (width)	R Min.	SC Straight	SC Curved	Weight (lbs. per ft.)
SSE 881O K325	10400	1574	12	3-1/4	20	1.75	1.63	2.01
SSE 881O K450	10401	1574	12	4-1/2	20	1.75	1.63	2.48
SSE 881O K750	10402	1574	12	7-1/2	20	1.75	1.63	3.69

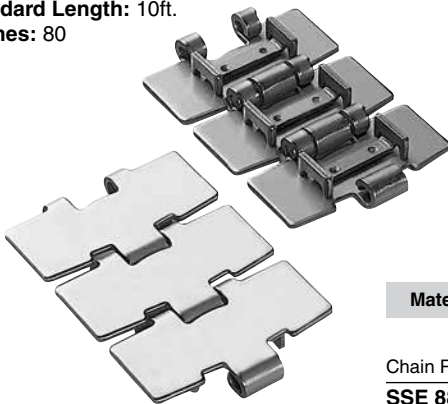

Side Flexing Steel Chains

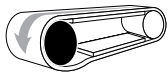

Drive Sprocket Options for 881 Chains



Machined Split

Molded Split

Shaft Sized Bore Dia.	Teeth or Equivalent	Part Number	Part Number
.71*	21	12967	-
1	21	32473	32061
1-1/4	21	32474	32062
1-7/16	21	32475	32063
1-1/2	21	-	32064
<hr/>			
.71*	23	12968	-
1	23	32477	32109
1-1/4	23	32478	32110
1-7/16	23	32479	32111
1-1/2	23	32480	32112
<hr/>			
.71*	25	12969	-
1	25	32481	32073
1-1/4	25	32482	32074
1-7/16	25	32483	32075
1-1/2	25	32484	32076
<hr/>			
.71*	27	121217	-
1	27	321218	-
1-1/4	27	321219	-
1-7/16	27	-	-
1-1/2	27	321221	-

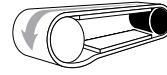

Idler Options for 881 Chains



Machined Split

Molded Split

Part Number	Part Number
-	-
-	-
-	-
-	-
-	-
<hr/>	
-	-
321283	-
321284	-
321285	-
321286	-
<hr/>	
-	-
321287	321120
321288	321121
321289	-
321290	-
<hr/>	
-	-
-	-
-	-
-	-
-	-

*Plain bore pilot hole. Not sized to a shaft.

See all sprockets and idlers on pages 101-125

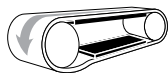

Track Options for 881 Chains

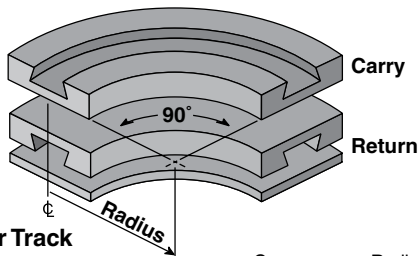

Corner Track

Part Number	Track Width	Carry or Return	Radius (inches)
VT-980-B-18-0325	3.75	Carry	18
VT-980-B-24-0325	3.75	Carry	24
VT-980-R-18-0325	3.75	Return	18
VT-980-R-24-0325	3.75	Return	24
VT-980-B-24-0450	5.0	Carry	24
VT-980-R-24-0450	5.0	Return	24
VT-981-B-24-0750	8.0	Carry	24
VT-981-R-24-0750	8.0	Return	24

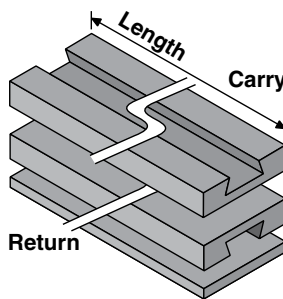

Straight Track

Part Number	Track Width	Carry or Return	Length (feet)
VT-980-B-S-0325-3	3.75	Carry	3
VT-980-B-S-0325-6	3.75	Carry	6
VT-980-B-S-0325-10	3.75	Carry	10
VT-980-R-S-0325-3	3.75	Return	3
VT-980-R-S-0325-6	3.75	Return	6
VT-980-R-S-0325-10	3.75	Return	10
VT-980-B-S-0450-3	5.0	Carry	3
VT-980-B-S-0450-6	5.0	Carry	6
VT-980-B-S-0450-10	5.0	Carry	10
VT-980-R-S-0450-10	5.0	Return	10
VT-981-B-S-0750-3	8.0	Carry	3
VT-981-B-S-0750-6	8.0	Carry	6
VT-981-B-S-0750-10	8.0	Carry	10
VT-981-R-S-0750-3	8.0	Return	3
VT-981-R-S-0750-6	8.0	Return	6
VT-981-R-S-0750-10	8.0	Return	10

See all ValuTrac modules on pages 130-145

881 TAB

Side Flexing Chains, TAB Guides

These chains feature high wear resistance, exceptional durability and hardness, and high tensile strength.

Standard Length: 10ft.

Pitches: 80

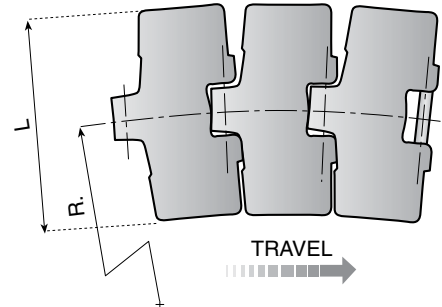
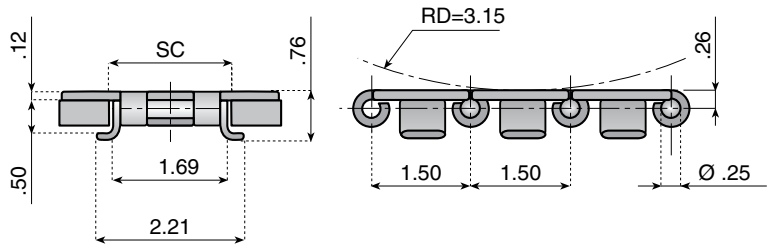
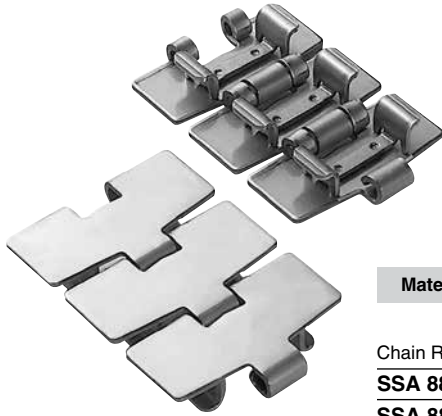

Material: 304 grade austenitic stainless steel.

Chain Reference	Part Number	Yield Point (lbs.)	Surface Finish (micro inches)	L (width)	R Min.	SC Straight	SC Curved	Weight (lbs. per ft.)
SSA 881 TAB K325	10110	1011	12	3-1/4	18	1.81	1.77	2.01
SSA 881 TAB K450	10111	1011	12	4-1/2	24	1.81	1.77	2.48
SSA 881 TAB K750	10112	1011	12	7-1/2	24	1.81	1.77	3.69

881O TAB

Side Flexing Chains, TAB Guides

881O TAB offers a further improvement to the standard chains series 881 TAB. This chain has a smaller gap between plates and therefore creates a larger surface area for conveying purposes while improving product stability.

Standard Length: 10ft.

Pitches: 80

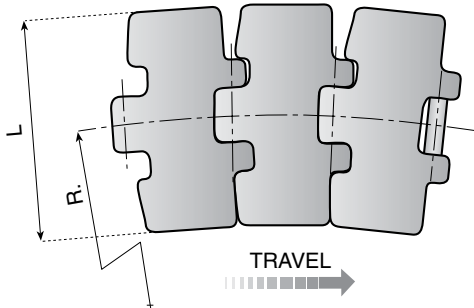
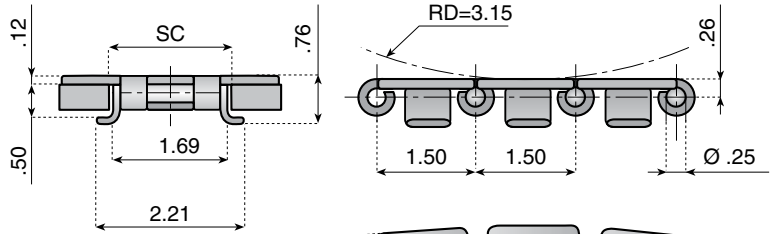
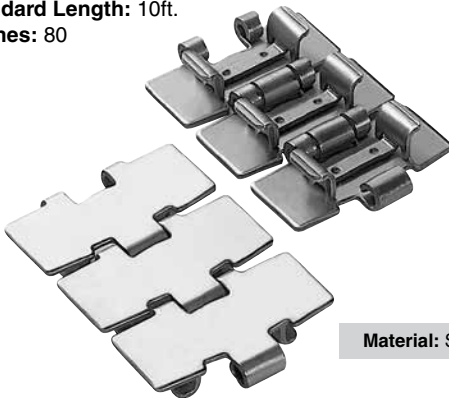

Material: Special 400 series "Extra Plus" high performance stainless steel.

Chain Reference	Part Number	Yield Point (lbs.)	Surface Finish (micro inches)	L (width)	R Min.	SC Straight	SC Curved	Weight (lbs. per ft.)
SSE 881O TAB K325	10403	1574	12	3-1/4	18	1.81	1.77	2.01
SSE 881O TAB K450	10404	1574	12	4-1/2	24	1.81	1.77	2.48
SSE 881O TAB K750	10405	1574	12	7-1/2	24	1.81	1.77	3.69

Side Flexing Steel Chains

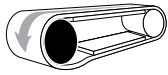

Drive Sprocket Options for 881TAB Chains



Machined Split

Molded Split

Shaft Sized Bore Dia.	Teeth or Equivalent	Part Number	Part Number
.71*	21	12967	-
1	21	32473	32061
1-1/4	21	32474	32062
1-7/16	21	32475	32063
1-1/2	21	-	32064
.71*	23	12968	-
1	23	32477	32109
1-1/4	23	32478	32110
1-7/16	23	32479	32111
1-1/2	23	32480	32112
.71*	25	12969	-
1	25	32481	32073
1-1/4	25	32482	32074
1-7/16	25	32483	32075
1-1/2	25	32484	32076
.71*	27	121217	-
1	27	321218	-
1-1/4	27	321219	-
1-7/16	27	-	-
1-1/2	27	321221	-

*Plain bore pilot hole. Not sized to a shaft.

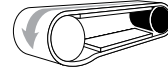

Idler Options for 881TAB Chains



Machined Split

Molded Split

Part Number	Part Number
-	-
-	-
-	-
-	-
-	-
-	-
-	-
321283	-
321284	-
321285	-
321286	-
-	-
321287	321120
321288	321121
321289	-
321290	-
-	-
-	-
-	-
-	-
-	-

See all sprockets and idlers on pages 101-125

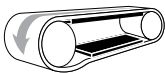

Track Options for 881TAB Chains

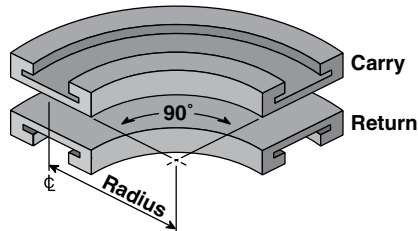

Corner Track

Part Number	Track Width	Radius (inches)
VT-980-T-18-0325	3.75	18
VT-980-T-24-0325	3.75	24
VT-980-T-24-0450	5.0	24
VT-981-T-24-0750	8.0	24

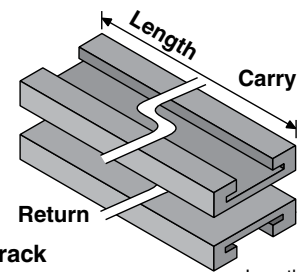

Straight Track

Part Number	Track Width	Length (feet)
VT-980-T-S-0325-3	3.75	3
VT-980-T-S-0325-6	3.75	6
VT-980-T-S-0325-10	3.75	10
VT-980-T-S-0450-3	5.0	3
VT-980-T-S-0450-6	5.0	6
VT-980-T-S-0450-10	5.0	10
VT-981-T-S-0750-3	8.0	3
VT-981-T-S-0750-6	8.0	6
VT-981-T-S-0750-10	8.0	10

See all ValuTrac modules on pages 130-145

Magnetic Side Flexing Steel Chains

881 M, 881 MO

Magnetic Side Flexing Chains

Series 881 M is securely retained in the curve by magnets embedded in the chain track material. There are no tabs or bevels on these chains, so they can be easily removed for maintenance or cleaning, without dismantling the chain.

Series 881 MO (Magnet Optimal) is a further development of the traditional series 881 M. With more material in each plate and smaller gaps between each link, improved product transfer and stability can be achieved.

In order to achieve this advantage, the minimum radius of the 3-1/4 version of this chain is 20".

Standard Length: 10ft.
Pitches: 80

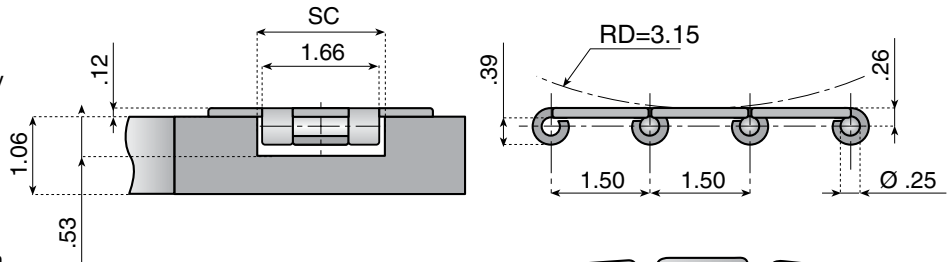
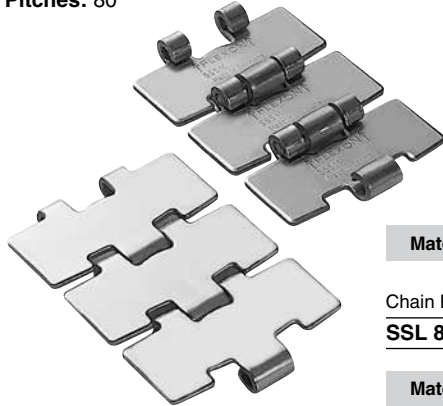

See page 146 for more information.

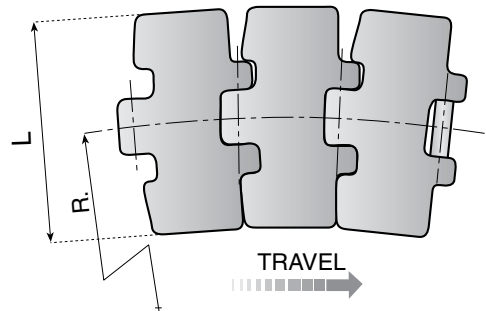

Material: "Standard" 430 grade ferritic stainless steel.

Chain Reference	Part Number	Yield Point (lbs.)	Surface Finish (micro inches)	Flatness (max)	Polished Hinges	L (width)	R Min.	SC	Weight (lbs. per ft.)
SSL 881 MO K325	10208L	1215	24	.004	yes	3-1/4	20	177	1.68

Material: Special 400 series "Extra Plus" high performance stainless steel.

Chain Reference	Part Number	Yield Point (lbs.)	Surface Finish (micro inches)	Flatness (max)	Polished Hinges	L (width)	R Min.	SC	Weight (lbs. per ft.)
SSEL 881 MO K325	10206L	1912	12	.004	yes	3-1/4	20	1.77	1.68
SSE 881 M K450	10201	1912	12	.008	no	4-1/2	20	1.77	2.08
SSE 881 M K750	10203	1912	12	.012	no	7-1/2	20	1.77	3.29

Material: Special 400 series "Extra Plus" high performance stainless steel. Pins are made from vacuum hardened stainless steel.

Chain Reference	Part Number	Yield Point (lbs.)	Surface Finish (micro inches)	L (width)	R Min.	SC	Weight (lbs. per ft.)
SSEL 881 MO K325 HB	10213L	1912	12	3-1/4	20	1.77	1.68

L881 MO (Speed-Line)

Magnetic Side Flexing Chains

Speed-Line chains feature all the advantages of the magnetic system, plus specially designed plates and hinges that allow for smooth transfers. High speed applications or pressure-less combiner areas are ideal for this type of chain. Other features include minimal gaps and an excellent surface finish.

Standard Length: 10ft.
Pitches: 80

Material: Special 400 series "Extra Plus" high performance stainless steel.

Chain Reference	Part Number	Yield Point (lbs.)	Surface Finish (micro inches)	Flatness (max)	Polished Hinges	L (width)	R Min.	SC	Weight (lbs. per ft.)
SPSL 881 MO K325	10255L	1912	8	.004	yes	3-1/4	20	1.77	1.68

Material: Special 400 series "Extra Plus" high performance stainless steel. Pins are made from vacuum hardened stainless steel.

SPSL 881 MO K325 HB	10265L	1912	8	.004	yes	3-1/4	20	1.77	1.68
----------------------------	---------------	-------------	----------	-------------	------------	--------------	-----------	-------------	-------------

Magnetic Side Flexing Steel Chains

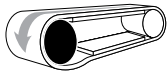

Drive Sprocket Options for 881 M, 881 MO Chains

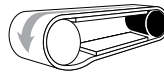

Idler Options for 881 M, 881 MO Chains

See all sprockets and idlers on pages 101-125



Shaft Sized Bore Dia.	Teeth or Equivalent	Machined Split Part Number	Molded Split Part Number	Machined Split Part Number	Molded Split Part Number	Low-Friction Molded Part Number	Molded Split Part Number
.71*	19	12905	-	-	-	-	-
1	19	12529S	-	121239S	-	-	-
1-1/4	19	12530S	-	121240S	-	-	-
1-7/16	19	12538S	-	121241S	-	-	-
1-1/2	19	12539S	-	121242S	-	-	-
.71*	21	12906	-	-	-	-	-
1	21	12540S	32053	121243S	321080	32866	32077B
1-1/4	21	12541S	32054	121244S	321081	32867	32078B
1-7/16	21	12542S	32055	121245S	321082	32868	32079B
1-1/2	21	12543S	32056	121246S	321083	32869	32080B
.71*	23	12907	-	-	-	-	-
1	23	12544S	32099	121247S	321085	32874	-
1-1/4	23	12545S	32100	121248S	321086	32875	-
1-7/16	23	12546S	32101	121249S	321087	32876	-
1-1/2	23	12547S	32102	121250S	321088	32877	-
.71*	25	12908	-	-	-	-	-
1	25	12548S	32065	121251S	321090	32870	32081B
1-1/4	25	12549S	32066	121252S	321091	32871	32082B
1-7/16	25	12550S	32067	121253S	321092	32872	32083B
1-1/2	25	12551S	32068	121254S	321093	32873	32084B
.71*	27	121199	-	-	-	-	-
1	27	121200S	-	121255S	-	-	-
1-1/4	27	121201S	-	121256S	-	-	-
1-7/16	27	121202S	-	121257S	-	-	-
1-1/2	27	121203S	-	121258S	-	-	-

*Plain bore pilot hole. Not sized to a shaft.

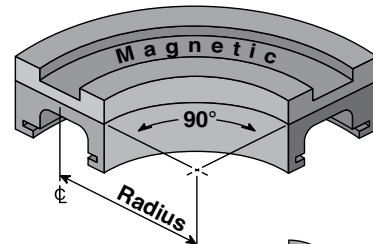
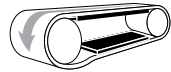

See all Magnetic Corner Tracks on pages 146-153

Track Options for 881 MO Chains / K325 and K330 Series

Number of Tracks	Total Width		Corner Angle					
	mm	inches	15°	30°	45°	60°	75°	90°
1	100	3.94	KMD.14.15.01.A	KMD.14.30.01.A	KMD.14.45.01.A	KMD.14.60.01.A	KMD.14.75.01.A	KMD.14.90.01.A
2	185	7.28	KMD.14.15.02.A	KMD.14.30.02.A	KMD.14.45.02.A	KMD.14.60.02.A	KMD.14.75.02.A	KMD.14.90.02.A
3	270	10.63	KMD.14.15.03.A	KMD.14.30.03.A	KMD.14.45.03.A	KMD.14.60.03.A	KMD.14.75.03.A	KMD.14.90.03.A
4	355	13.98	KMD.14.15.04.A	KMD.14.30.04.A	KMD.14.45.04.A	KMD.14.60.04.A	KMD.14.75.04.A	KMD.14.90.04.A

Track Options for 881 M Chains / K450 Series

Number of Tracks	Total Width		Corner Angle					
	mm	inches	15°	30°	45°	60°	75°	90°
1	129	5.08	KMD.23.15.01.A	KMD.23.30.01.A	KMD.23.45.01.A	KMD.23.60.01.A	KMD.23.75.01.A	KMD.23.90.01.A
2	246	9.69	KMD.23.15.02.A	KMD.23.30.02.A	KMD.23.45.02.A	KMD.23.60.02.A	KMD.23.75.02.A	KMD.23.90.02.A
3	363	14.29	KMD.23.15.03.A	KMD.23.30.03.A	KMD.23.45.03.A	KMD.23.60.03.A	KMD.23.75.03.A	KMD.23.90.03.A
4	480	18.90	KMD.23.15.04.A	KMD.23.30.04.A	KMD.23.45.04.A	KMD.23.60.04.A	KMD.23.75.04.A	KMD.23.90.04.A

Track Options for 881 MO Chains / K750 Series

Number of Tracks	Total Width		Corner Angle					
	mm	inches	15°	30°	45°	60°	75°	90°
1	214	8.43	KMD.31.15.01.A	KMD.31.30.01.A	KMD.31.45.01.A	KMD.31.60.01.A	KMD.31.75.01.A	KMD.31.90.01.A
2	410	16.14	KMD.31.15.02.A	KMD.31.30.02.A	KMD.31.45.02.A	KMD.31.60.02.A	KMD.31.75.02.A	KMD.31.90.02.A
3	606	23.86	KMD.31.15.03.A	KMD.31.30.03.A	KMD.31.45.03.A	KMD.31.60.03.A	KMD.31.75.03.A	KMD.31.90.03.A

For additional number of tracks in a magnetic curve, see the chain track catalog section.

Straight Running Plastic Chains

820

Straight Running Chains, Single Hinge

Low noise level, low coefficient of friction, and low horsepower requirements are the advantages of these chains. They provide an excellent flat surface and medium working load in a dry running environment.

Applications for the food and beverage industry include conveying lines for PET bottles and aluminium or steel cans. Lines packaging PET bottle packs in heat shrink film, paper board boxes, or cans in heat shrink film, can also be fitted with these chains. Pharmaceutical industry applications include all general purpose conveying.

Standard Length: 10ft.
Pitches: 80

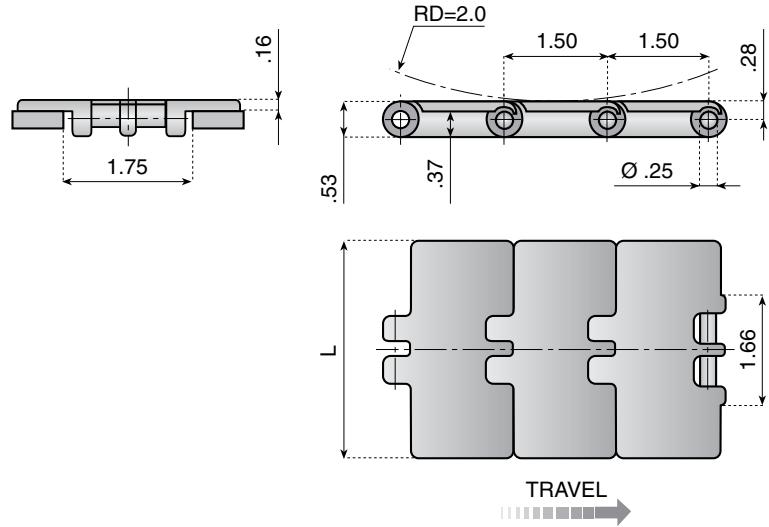
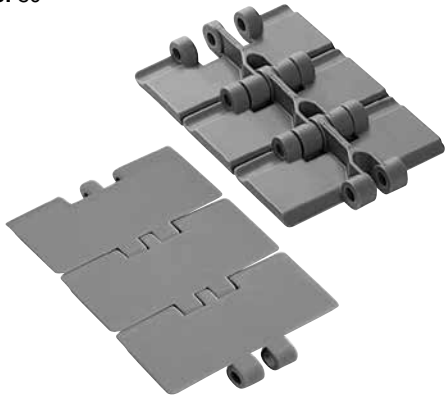

Material: "LF Brown" Low friction acetal with 304 stainless steel pins.

Chain Reference	Part Number	Breaking Load (lbs.)	L (width)	Weight (lbs. per ft.)
LF 820 K325	11362	1124	3-1/4	.57
LF 820 K400	11365	1124	4	.64
LF 820 K450	11368	1124	4-1/2	.69
LF 820 K600	11371	1124	6	.84
LF 820 K750	11374	1124	7-1/2	.99

Material: "XPG Dark Grey" Very low friction acetal with 304 stainless steel pins.

Chain Reference	Part Number	Breaking Load (lbs.)	L (width)	Weight (lbs. per ft.)
XPG 820 K325	11100G	1079	3-1/4	.57
XPG 820 K450	11102G	1079	4-1/2	.69
XPG 820 K600	11103G	1079	6	.84
XPG 820 K750	11104G	1079	7-1/2	.99

Material: "NG Green" Our proprietary lowest friction PBT with 304 stainless steel pins.

Chain Reference	Part Number	Breaking Load (lbs.)	L (width)	Weight (lbs. per ft.)
NG 820 K325	11151	899	3-1/4	.57
NG 820 K450	11154	899	4-1/2	.69
NG 820 K600	11155	899	6	.84
NG 820 K750	11156	899	7-1/2	.99

Straight Running Plastic Chains

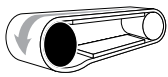

Drive Sprocket Options for 820 Chains



Machined Split



Molded Split

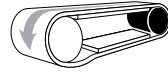

Idler Options for 820 Chains



Machined Split



Molded Split



Low-Friction Molded



Molded Split

Shaft Sized Bore Dia.	Teeth or Equivalent	Machined Split Part Number	Molded Split Part Number	Machined Split Part Number	Molded Split Part Number	Low-Friction Molded Part Number	Molded Split Part Number
.71*	19	12961	-	-	-	-	-
1	19	12924S	-	121147S	-	-	-
1-1/4	19	12925S	-	121148S	-	-	-
1-7/16	19	12926S	-	121149S	-	-	-
1-1/2	19	12927S	-	121150S	-	-	-
.71*	21	12962	-	-	-	-	-
1	21	12928S	32057	121151S	321095	32866	32077B
1-1/4	21	12929S	32058	121152S	321096	32867	32078B
1-7/16	21	12930S	32059	121153S	321097	32868	32079B
1-1/2	21	12931S	32060	121154S	321098	32869	32080B
.71*	23	12963	-	-	-	-	-
1	23	12932S	32104	121155S	321100	32874	-
1-1/4	23	12933S	32105	121156S	321101	32875	-
1-7/16	23	12934S	32106	121157S	321102	32876	-
1-1/2	23	12935S	32107	121158S	321103	32877	-
.71*	25	12964	-	-	-	-	-
1	25	12936S	32069	121159S	321105	32870	32081B
1-1/4	25	12937S	32070	121160S	321106	32871	32082B
1-7/16	25	12938S	32071	121161S	321107	32872	32083B
1-1/2	25	12939S	32072	121162S	321108	32873	32084B
.71*	27	121125	-	-	-	-	-
1	27	121126S	-	121163S	-	-	-
1-1/4	27	121127S	-	121164S	-	-	-
1-7/16	27	121128S	-	121165S	-	-	-
1-1/2	27	121129S	-	121166S	-	-	-

*Plain bore pilot hole. Not sized to a shaft.

See all sprockets and idlers on pages 101-125

Straight Running Plastic Chains

831

Straight Running Chains, Single Hinge

Low noise level, low coefficient of friction, and low horsepower requirements are the advantages of these chains. They provide an excellent flat surface and medium working load in a dry running environment.

Applications for the food and beverage industry include conveying lines for PET bottles and aluminium or steel cans. Lines packaging PET bottle packs in heat shrink film, paper board boxes, or cans in heat shrink film, can also be fitted with these chains. Pharmaceutical industry applications include all general purpose conveying.

The added thickness (3/16 in.) of the 831 series top plate adds 20% more wear life, and simplifies conveyor design when matching with chain series: 821, 879, 882, 878.

Standard Length: 10ft.
Pitches: 80

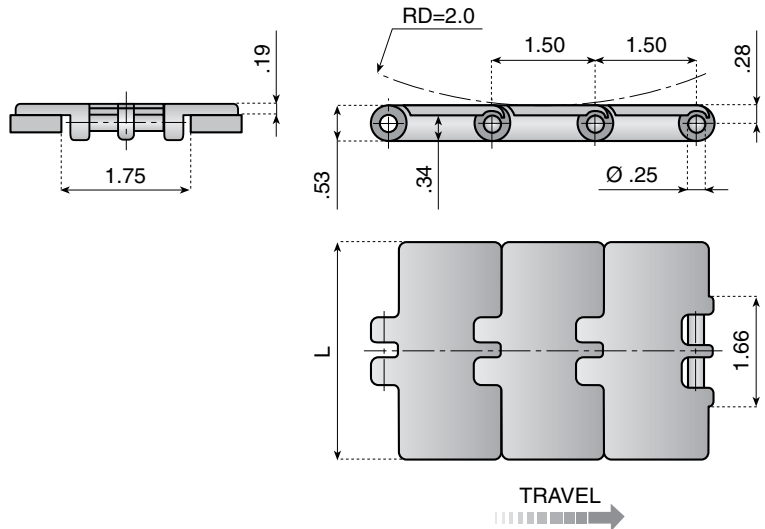
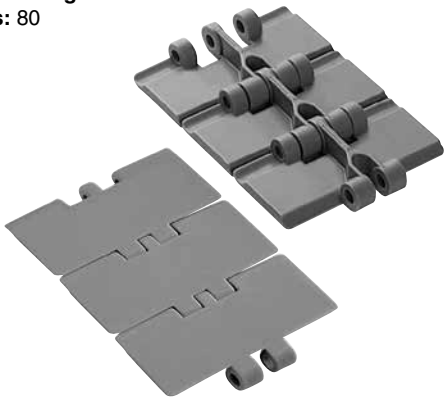

Material: "LF Brown" Low friction acetal with 304 stainless steel pins.

Chain Reference	Part Number	Breaking Load (lbs.)	L (width)	Weight (lbs. per ft.)
LF 831 K325	11607	1124	3-1/4	.70
LF 831 K450	11608	1124	4-1/2	.86
LF 831 K750	11609	1124	7-1/2	1.22

Material: "XPG Dark Grey" Very low friction acetal with 304 stainless steel pins.

Chain Reference	Part Number	Breaking Load (lbs.)	L (width)	Weight (lbs. per ft.)
XPG 831 K325	11105G	1079	3-1/4	.70
XPG 831 K450	11106G	1079	4-1/2	.86
XPG 831 K750	11107G	1079	7-1/2	1.22

Material: "NG Green" Our proprietary lowest friction PBT with 304 stainless steel pins.

Chain Reference	Part Number	Breaking Load (lbs.)	L (width)	Weight (lbs. per ft.)
NG 831 K325	11160	899	3-1/4	.70
NG 831 K450	11161	899	4-1/2	.86
NG 831 K750	11162	899	7-1/2	1.22

Straight Running Plastic Chains

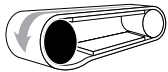

Drive Sprocket Options for 831 Chains



Machined Split



Molded Split

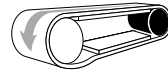

Idler Options for 831 Chains



Machined Split



Molded Split



Low-Friction Molded



Molded Split

Shaft Sized Bore Dia.	Teeth or Equivalent	Part Number	Part Number	Part Number	Part Number	Part Number	Part Number
.71*	19	12961	-	-	-	-	-
1	19	12924S	-	121147S	-	-	-
1-1/4	19	12925S	-	121148S	-	-	-
1-7/16	19	12926S	-	121149S	-	-	-
1-1/2	19	12927S	-	121150S	-	-	-
.71*	21	12962	-	-	-	-	-
1	21	12928S	32057	121151S	321095	32866	32077B
1-1/4	21	12929S	32058	121152S	321096	32867	32078B
1-7/16	21	12930S	32059	121153S	321097	32868	32079B
1-1/2	21	12931S	32060	121154S	321098	32869	32080B
.71*	23	12963	-	-	-	-	-
1	23	12932S	32104	121155S	321100	32874	-
1-1/4	23	12933S	32105	121156S	321101	32875	-
1-7/16	23	12934S	32106	121157S	321102	32876	-
1-1/2	23	12935S	32107	121158S	321103	32877	-
.71*	25	12964	-	-	-	-	-
1	25	12936S	32069	121159S	321105	32870	32081B
1-1/4	25	12937S	32070	121160S	321106	32871	32082B
1-7/16	25	12938S	32071	121161S	321107	32872	32083B
1-1/2	25	12939S	32072	121162S	321108	32873	32084B
.71*	27	121125	-	-	-	-	-
1	27	121126S	-	121163S	-	-	-
1-1/4	27	121127S	-	121164S	-	-	-
1-7/16	27	121128S	-	121165S	-	-	-
1-1/2	27	121129S	-	121166S	-	-	-

*Plain bore pilot hole. Not sized to a shaft.

See all sprockets and idlers on pages 101-125

828

Straight Running Chains

- Very versatile
- Higher load capacity than standard series
- Can be used in combination with 880 series
- Improved product stability

Applications for the food and beverage industry include conveying lines for PET bottles and aluminium or steel cans. Lines packaging PET bottle packs in heat shrink film, paper board boxes, or cans in heat shrink film, can also be fitted with these chains. Pharmaceutical industry applications include all general purpose conveying.

Standard Length: 10ft.
Pitches: 80

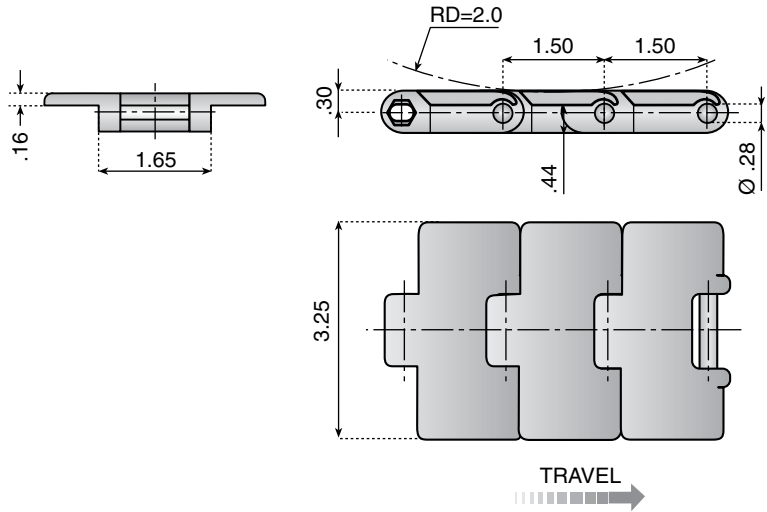

Material: "LF Brown" Low friction acetal with 304 stainless steel pins.

Chain Reference	Part Number	Breaking Load (lbs.)	L (width)	Weight (lbs. per ft.)
LF 828 K325	11130	1349	3-1/4	.60

Material: "XPG Dark Grey" Very low friction acetal with 304 stainless steel pins.

Chain Reference	Part Number	Breaking Load (lbs.)	L (width)	Weight (lbs. per ft.)
XPG 828 K325	11132G	1259	3-1/4	.60

Material: "NG Green" Proprietary lowest friction PBT with 304 stainless steel pins.

Chain Reference	Part Number	Breaking Load (lbs.)	L (width)	Weight (lbs. per ft.)
NG 828 K325	11134	1124	3-1/4	.62

Special features of the 828 series:

- ✓ **Compatibility**
Same hinge width and plate thickness as 820 series chains.
Can be used adjacent to 820 and 880 chains.
- ✓ **Uses the same sprockets as 878, 879, 880 series chains**
- ✓ **High Load Capacity**
Rated higher than 820 series chains.
More freedom for conveyor design.
- ✓ **Improved Design**
Reduced gap between adjacent tracks.
Top plate and hinge surfaces improve product stability.

Straight Running Plastic Chains

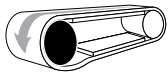

Drive Sprocket Options for 828 Chains



Machined Split

Molded Split

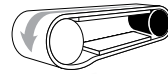

Idler Options for 828 Chains



Machined Split

Molded Split

Low-Friction Molded

Molded Split

Shaft Sized Bore Dia.	Teeth or Equivalent	Machined Split Part Number	Molded Split Part Number	Machined Split Part Number	Molded Split Part Number	Low-Friction Molded Part Number	Molded Split Part Number
.71*	9	12910	-	-	-	-	-
1	9	12382S	-	121752S	-	-	-
1-1/4	9	12383S	-	121753S	-	-	-
1-7/16	9	12384S	-	121754S	-	-	-
1-1/2	9	12385S	-	121755S	-	-	-
.71*	10	12911	-	-	-	-	-
1	10	12386S	321001	121756S	321005	32866	32077B
1-1/4	10	12387S	321002	121757S	321006	32867	32078B
1-7/16	10	12388S	321003	121758S	321007	32868	32079B
1-1/2	10	12389S	321004	121759S	321008	32869	32080B
.71*	11	12912	-	-	-	-	-
1	11	12390S	-	121760S	-	-	-
1-1/4	11	12391S	-	121761S	-	-	-
1-7/16	11	12392S	-	121762S	-	-	-
1-1/2	11	12393S	-	121763S	-	-	-
.71*	12	12913	-	-	-	-	-
1	12	12394S	32400	121764S	32403	32870	32081B
1-1/4	12	12395S	32711	121765S	32404	32871	32082B
1-7/16	12	12396S	32401	121766S	32405	32872	32083B
1-1/2	12	12397S	32402	121767S	32406	32873	32084B

*Plain bore pilot hole. Not sized to a shaft.

See all sprockets and idlers on pages 101-125

Straight Running Plastic Chains

821

Straight Running Chains Double Hinge

With a double hinge and double reinforcing bars, these chains have a load capacity similar to single hinge stainless steel chains.

Low noise level, low coefficient of friction, and low horsepower requirements are the advantages of these chains. They provide a high working load in a dry running environment.

Standard Length: 10ft.
Pitches: 80

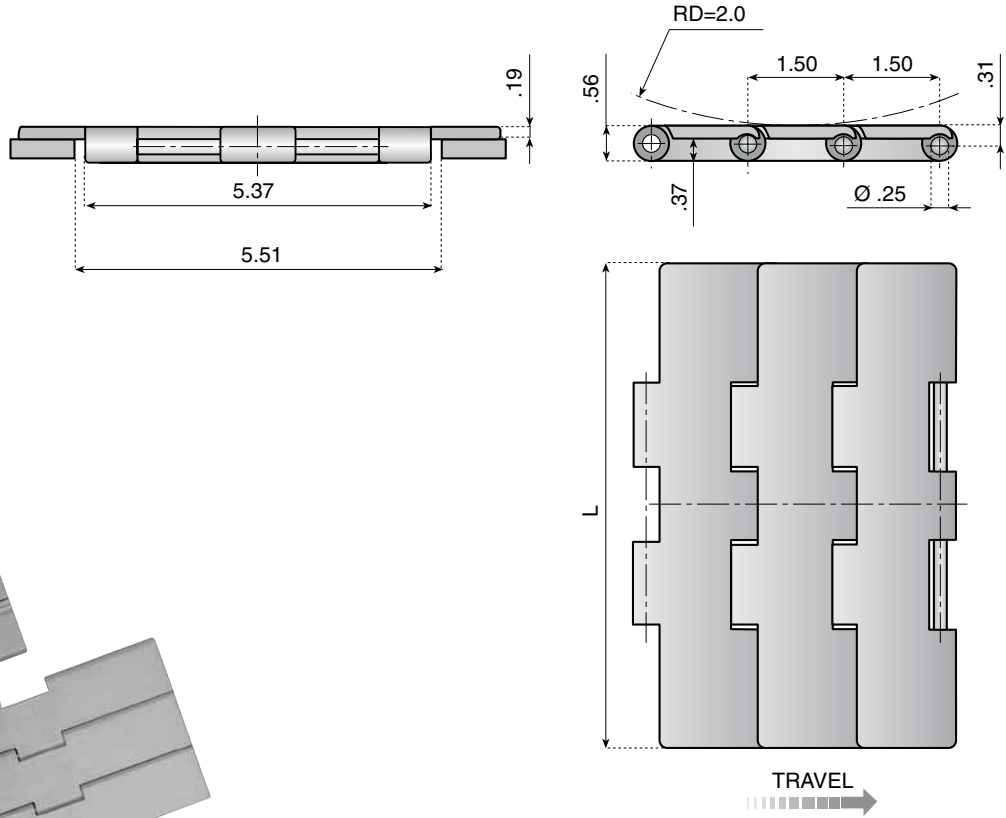
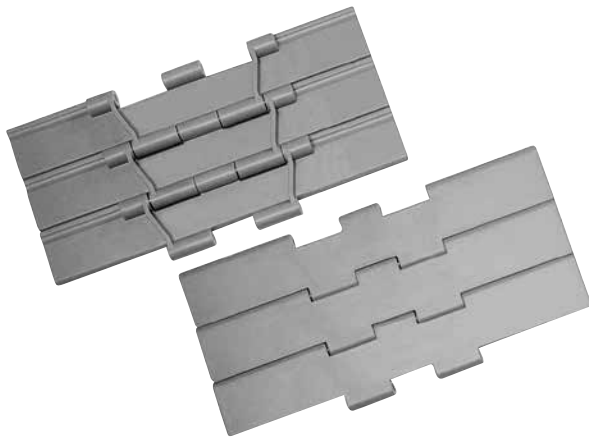

Material: "LF Brown" Low friction acetal with 304 stainless steel pins.

Chain Reference	Part Number	Breaking Load (lbs.)	L (width)	Weight (lbs. per ft.)
LF 821 K750	11002	1866	7-1/2	1.74
LF 821 K1000	11004	1866	10	2.08
LF 821 K1200	11006	1866	12	2.25

Material: "XPG Dark Grey" Very low friction acetal with 304 stainless steel pins.

Chain Reference	Part Number	Breaking Load (lbs.)	L (width)	Weight (lbs. per ft.)
XPG 821 K750	11510G	1821	7-1/2	1.74
XPG 821 K1000	11511G	1821	10	2.08
XPG 821 K1200	11512G	1821	12	2.25

Material: "NG Green" Our proprietary lowest friction PBT with 304 stainless steel pins.

Chain Reference	Part Number	Breaking Load (lbs.)	L (width)	Weight (lbs. per ft.)
NG 821 K750	11170	1753	7-1/2	1.74
NG 821 K1000	11171	1753	10	2.08
NG 821 K1200	11172	1753	12	2.25

Straight Running Plastic Chains

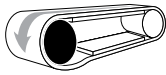

Drive Sprocket Options for 821 Chains

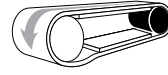

Idler Options for 821 Chains



Machined Split

Molded



Machined Split

Molded

Shaft Sized Bore Dia.	Teeth or Equivalent	Part Number		Part Number	
.71*	21	12901	-	-	-
1	21	12284S	-	121329S	-
1-1/4	21	12285S	-	121330S	-
1-7/16	21	12286S	-	121331S	-
1-1/2	21	12287S	-	121332S	-
.71*	23	12902	-	-	-
1	23	12288S	-	121333S	-
1-1/4	23	12289S	-	121334S	-
1-7/16	23	12290S	-	121335S	-
1-1/2	23	12291S	-	121336S	-
.71*	25	12903	-	-	-
1	25	12292S	32085	121337S	32089
1-1/4	25	12293S	32086	121338S	32090
1-7/16	25	12294S	32086S	121339S	32090S
1-1/2	25	12295S	32087	121340S	32091
.71*	27	121307	-	-	-
1	27	121308S	-	121341S	-
1-1/4	27	121309S	-	121342S	-
1-7/16	27	121310S	-	121343S	-
1-1/2	27	121311S	-	121344S	-

*Plain bore pilot hole. Not sized to a shaft.

See all sprockets and idlers on pages 101-125

Side Flexing Plastic Chains

878 TAB

Side Flexing Chains, Tab Guides

The new 878 TAB series enables the designer and the manufacturer of conveyors to reduce the average radius in turns. This unique chain solves conveying problems in confined spaces. It can also be used where products are conveyed on an incline or decline.

Other advantages include:

- Small sideflexing radius of 7-7/8 inches.
- Specially shaped flites with a radius on the edges designed to improve product transfer.
- Preferred usage with turn discs.

Applications for the food and beverage industry include conveying lines for PET bottles and aluminium or steel cans. Lines packaging PET bottle packs in heat shrink film, paper board boxes, or cans in heat shrink film, can also be fitted with these chains. Pharmaceutical industry applications include all general purpose conveying.

Standard Length: 10ft.

Pitches: 80

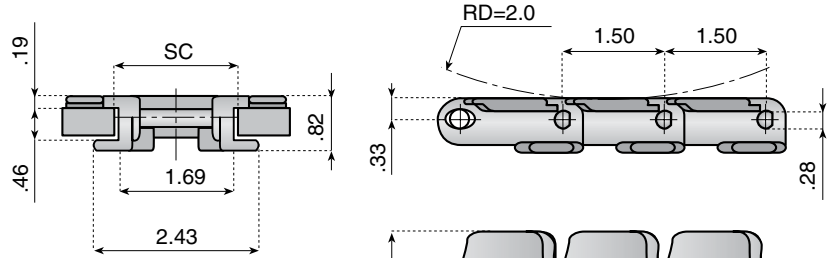

**7 7/8 inch
side flexing radius!**



Material: "LF Brown" Low friction acetal with 304 stainless steel pins.

Chain Reference	Part Number	Breaking Load (lbs.)	L (width)	R Min.	SC	Weight (lbs. per ft.)
LF 878 TAB K325	11390	1349	3-1/4	7.87	1.77	.73
LF 878 TAB K450	11389	1349	4-1/2	7.87	1.77	.81

Material: "XPG Dark Grey" Very low friction acetal with 304 stainless steel pins.

Chain Reference	Part Number	Breaking Load (lbs.)	L (width)	R Min.	SC	Weight (lbs. per ft.)
XPG 878 TAB K325	11420G	1281	3-1/4	7.87	1.77	.73

Side Flexing Plastic Chains

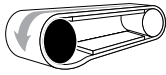

Drive Sprocket Options for 878 TAB Chains



Machined Split

Molded Split

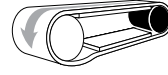

Idler Options for 878 TAB Chains



Machined Split

Molded Split

Shaft Sized Bore Dia.	Teeth or Equivalent	Part Number	Part Number	Part Number	Part Number
.71*	9	12910	-	-	-
1	9	12382S	-	121752S	-
1-1/4	9	12383S	-	121753S	-
1-7/16	9	12384S	-	121754S	-
1-1/2	9	12385S	-	121755S	-
.71*	10	12911	-	-	-
1	10	12386S	321001	121756S	321005
1-1/4	10	12387S	321002	121757S	321006
1-7/16	10	12388S	321003	121758S	321007
1-1/2	10	12389S	321004	121759S	321008
.71*	11	12912	-	-	-
1	11	12390S	-	121760S	-
1-1/4	11	12391S	-	121761S	-
1-7/16	11	12392S	-	121762S	-
1-1/2	11	12393S	-	121763S	-
.71*	12	12913	-	-	-
1	12	12394S	32400	121764S	32403
1-1/4	12	12395S	32711	121765S	32404
1-7/16	12	12396S	32401	121766S	32405
1-1/2	12	12397S	32402	121767S	32406

*Plain bore pilot hole. Not sized to a shaft.

See all sprockets and idlers on pages 101-125

Improved Turning Disk Designs!

These chains can also use horizontal disks, ideal for numerous curves or alpine applications. See page 126 for complete details.

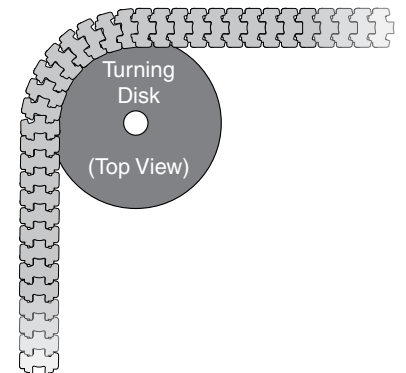

Side Flexing Plastic Chains

879, 880

Side Flexing Chains, Bevel Guide

Applications for the food and beverage industry include conveying lines for PET bottles and aluminium or steel cans. Lines packaging PET bottle packs in heat shrink film, paper board boxes, or cans in heat shrink film, can also be fitted with these chains. Pharmaceutical industry applications include all general purpose conveying.

The added thickness (3/16 in.) of the 879 series top plate adds 20% more wear life, and simplifies conveyor design when matching with chain series: 821, 831, 878, 879, and 882.

Standard Length: 10ft.
Pitches: 80

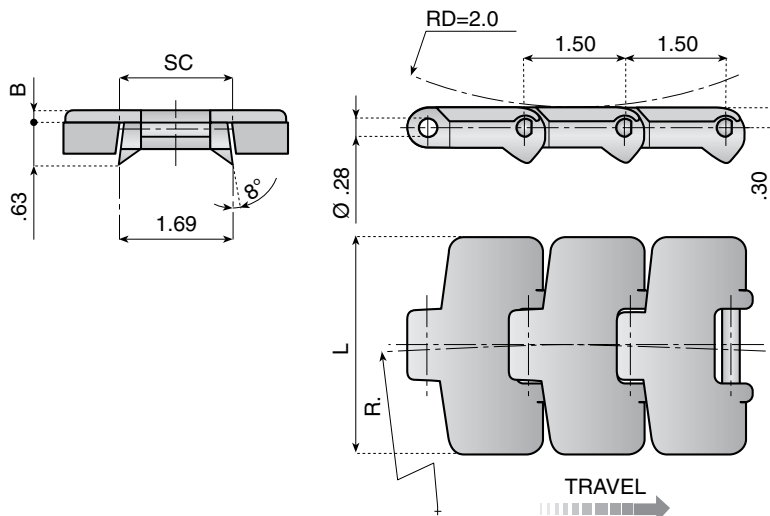
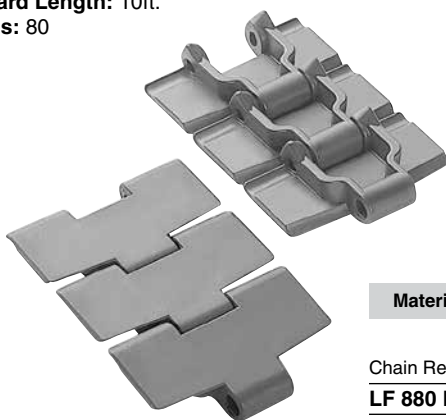

Material: "LF Brown" Low friction acetal with 304 stainless steel pins.

Chain Reference	Part Number	Breaking Load (lbs.)	L (width)	B (thickness)	R Min.	SC Straight	SC Curved	Weight (lbs. per ft.)
LF 880 K325	11383	1349	3-1/4	.16	18	1.75	1.63	.60
LF 880 K450	11386	1349	4-1/2	.16	18	1.75	1.63	.70
LF 879 K325	11506	1349	3-1/4	.19	18	1.75	1.63	.62
LF 879 K450	11507	1349	4-1/2	.19	18	1.75	1.63	.74

Material: "XPG Dark Grey" Very low friction acetal with 304 stainless steel pins.

Chain Reference	Part Number	Breaking Load (lbs.)	L (width)	B (thickness)	R Min.	SC Straight	SC Curved	Weight (lbs. per ft.)
XPG 880 K325	11502G	1281	3-1/4	.16	18	1.75	1.63	.60
XPG 880 K450	11503G	1281	4-1/2	.16	18	1.75	1.63	.70
XPG 879 K325	11508G	1281	3-1/4	.19	18	1.75	1.63	.62
XPG 879 K450	11509G	1281	4-1/2	.19	18	1.75	1.63	.74

Material: "NG Green" Our proprietary lowest friction PBT with 304 stainless steel pins.

Chain Reference	Part Number	Breaking Load (lbs.)	L (width)	B (thickness)	R Min.	SC Straight	SC Curved	Weight (lbs. per ft.)
NG 880 K325	11187	1124	3-1/4	.16	18	1.75	1.63	.60
NG 880 K450	11185	1124	4-1/2	.16	18	1.75	1.63	.70
NG 879 K325	11193	1124	3-1/4	.19	18	1.75	1.63	.62
NG 879 K450	11194	1124	4-1/2	.19	18	1.75	1.63	.74

Side Flexing Plastic Chains

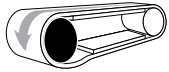

Drive Sprocket Options for 879, 880 Chains



Machined Split

Molded Split

Shaft Sized Bore Dia.	Teeth or Equivalent	Part Number	Part Number
.71*	9	12910	-
1	9	12382S	-
1-1/4	9	12383S	-
1-7/16	9	12384S	-
1-1/2	9	12385S	-
.71*	10	12911	-
1	10	12386S	321001
1-1/4	10	12387S	321002
1-7/16	10	12388S	321003
1-1/2	10	12389S	321004
.71*	11	12912	-
1	11	12390S	-
1-1/4	11	12391S	-
1-7/16	11	12392S	-
1-1/2	11	12393S	-
.71*	12	12913	-
1	12	12394S	32400
1-1/4	12	12395S	32711
1-7/16	12	12396S	32401
1-1/2	12	12397S	32402

*Plain bore pilot hole. Not sized to a shaft.

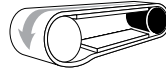

Idler Options for 879, 880 Chains



Machined Split

Molded Split

Low-Friction Molded

Molded Split

Part Number	Part Number	Part Number	Part Number
-	-	-	-
121752S	-	-	-
121753S	-	-	-
121754S	-	-	-
121755S	-	-	-
121756S	321005	32866	32077B
121757S	321006	32867	32078B
121758S	321007	32868	32079B
121759S	321008	32869	32080B
-	-	-	-
121760S	-	-	-
121761S	-	-	-
121762S	-	-	-
121763S	-	-	-
-	-	-	-
121764S	32403	32870	32081B
121765S	32404	32871	32082B
121766S	32405	32872	32083B
121767S	32406	32873	32084B

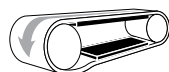

Track Options for 879, 880 Chains

See all sprockets and idlers on pages 101-125

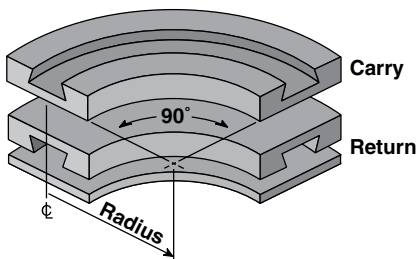

Corner Track

Part Number	Track Width	Carry or Return	Radius (inches)
VT-980-B-18-0325	3.75	Carry	18
VT-980-B-24-0325	3.75	Carry	24
VT-980-R-18-0325	3.75	Return	18
VT-980-R-24-0325	3.75	Return	24
VT-980-B-24-0450	5.0	Carry	24
VT-980-R-24-0450	5.0	Return	24

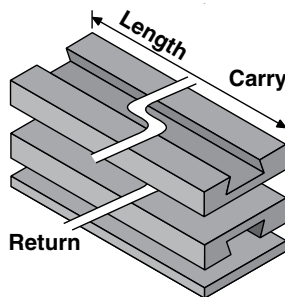

Straight Track

Part Number	Track Width	Carry or Return	Length (feet)
VT-980-B-S-0325-3	3.75	Carry	3
VT-980-B-S-0325-6	3.75	Carry	6
VT-980-B-S-0325-10	3.75	Carry	10
VT-980-R-S-0325-3	3.75	Return	3
VT-980-R-S-0325-6	3.75	Return	6
VT-980-R-S-0325-10	3.75	Return	10
VT-980-B-S-0450-3	5.0	Carry	3
VT-980-B-S-0450-6	5.0	Carry	6
VT-980-B-S-0450-10	5.0	Carry	10
VT-980-R-S-0450-10	5.0	Return	1

See all ValuTrac modules on pages 130-145

Side Flexing Plastic Chains

879 TAB, 880 TAB

Side Flexing Chains, TAB Guides

Applications for the food and beverage industry include conveying lines for PET bottles and aluminium or steel cans. Lines packaging PET bottle packs in heat shrink film, paper board boxes, or cans in heat shrink film, can also be fitted with these chains. Pharmaceutical industry applications include all general purpose conveying.

The added thickness (3/16 in.) of the 879 TAB series top plate adds 20% more wear life, and simplifies conveyor design when matching with chain series: 821, 831, 878, 879, and 882.

Standard Length: 10ft.
Pitches: 80

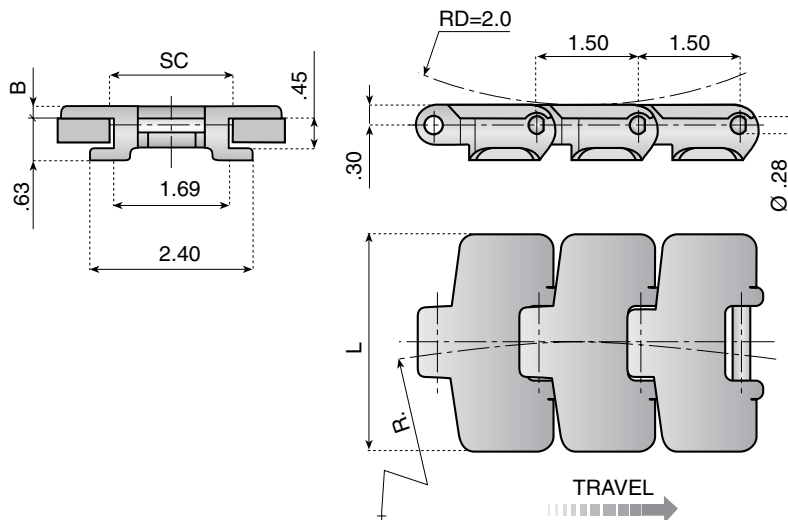
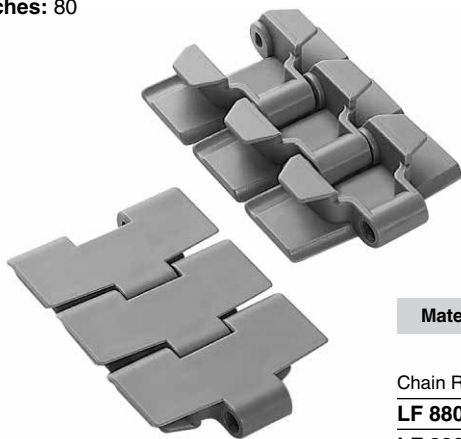

Material: "LF Brown" Low friction acetal with 304 stainless steel pins.

Chain Reference	Part Number	Breaking Load (lbs.)	L (width)	B (thickness)	R Min.	SC Straight	SC Curved	Weight (lbs. per ft.)
LF 880 TAB K325	11377	1349	3-1/4	.16	18	1.81	1.77	.63
LF 880 TAB K450	11380	1349	4-1/2	.16	18	1.81	1.77	.72
LF 879 TAB K325	11377ST	1349	3-1/4	.19	18	1.81	1.77	.66
LF 879 TAB K450	11380ST	1349	4-1/2	.19	18	1.81	1.77	.76

Material: "XPG Dark Grey" Very low friction acetal with 304 stainless steel pins.

Chain Reference	Part Number	Breaking Load (lbs.)	L (width)	B (thickness)	R Min.	SC Straight	SC Curved	Weight (lbs. per ft.)
XPG 880 TAB K325	11500G	1281	3-1/4	.16	18	1.81	1.77	.63
XPG 880 TAB K450	11501G	1281	4-1/2	.16	18	1.81	1.77	.72
XPG 879 TAB K325	11504G	1281	3-1/4	.19	18	1.81	1.77	.66
XPG 879 TAB K450	11505G	1281	4-1/2	.19	18	1.81	1.77	.76

Material: "NG Green" Our proprietary lowest friction PBT with 304 stainless steel pins.

Chain Reference	Part Number	Breaking Load (lbs.)	L (width)	B (thickness)	R Min.	SC Straight	SC Curved	Weight (lbs. per ft.)
NG 880 TAB K325	11195	1124	3-1/4	.16	18	1.81	1.77	.63
NG 880 TAB K450	11197	1124	4-1/2	.16	18	1.81	1.77	.72
NG 879 TAB K325	11198	1124	3-1/4	.19	18	1.81	1.77	.66
NG 879 TAB K450	11199	1124	4-1/2	.19	18	1.81	1.77	.76

Side Flexing Plastic Chains

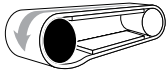

Drive Sprocket Options for 879, 880 TAB Chains



Machined Split

Molded Split

Shaft Sized Bore Dia.	Teeth or Equivalent	Part Number	Part Number
.71*	9	12910	-
1	9	12382S	-
1-1/4	9	12383S	-
1-7/16	9	12384S	-
1-1/2	9	12385S	-
.71*	10	12911	-
1	10	12386S	321001
1-1/4	10	12387S	321002
1-7/16	10	12388S	321003
1-1/2	10	12389S	321004
.71*	11	12912	-
1	11	12390S	-
1-1/4	11	12391S	-
1-7/16	11	12392S	-
1-1/2	11	12393S	-
.71*	12	12913	-
1	12	12394S	32400
1-1/4	12	12395S	32711
1-7/16	12	12396S	32401
1-1/2	12	12397S	32402

*Plain bore pilot hole. Not sized to a shaft.

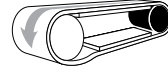

Idler Options for 879, 880 TAB Chains



Machined Split

Molded Split

Part Number	Part Number
-	-
121752S	-
121753S	-
121754S	-
121755S	-
-	-
121756S	321005
121757S	321006
121758S	321007
121759S	321008
-	-
121760S	-
121761S	-
121762S	-
121763S	-
-	-
121764S	32403
121765S	32404
121766S	32405
121767S	32406

See all sprockets and idlers on pages 101-125

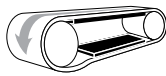

Track Options for 879, 880 TAB Chains

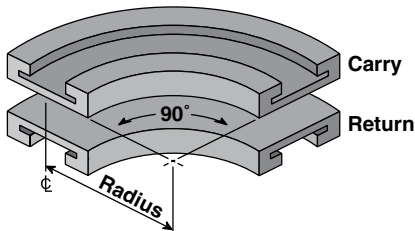

Corner Track

Part Number	Track Width	Radius (inches)
VT-980-T-18-0325	3.75	18
VT-980-T-24-0325	3.75	24
VT-980-T-24-0450	5.0	24

See all ValuTrac modules on pages 130-145

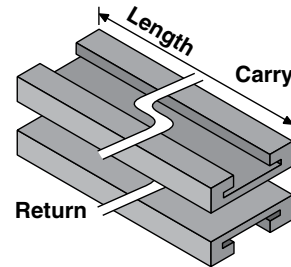

Straight Track

Part Number	Track Width	Length (feet)
VT-980-T-S-0325-3	3.75	3
VT-980-T-S-0325-6	3.75	6
VT-980-T-S-0325-10	3.75	10
VT-980-T-S-0450-3	5.0	3
VT-980-T-S-0450-6	5.0	6
VT-980-T-S-0450-10	5.0	10

879 M, 880 M

Magnetic Side Flexing Chains

These chains are securely retained in the curve by magnets embedded in the chain track material. There are no tabs or bevels, so they can be easily removed for maintenance or cleaning, without dismantling the chain.

The added thickness (3/16 in.) of the 879 M series top plate adds 20% more wear life, and simplifies conveyor design when matching with chain series: 821, 831, 879, 879 TAB, and 882.

Standard Length: 10ft.
Pitches: 80

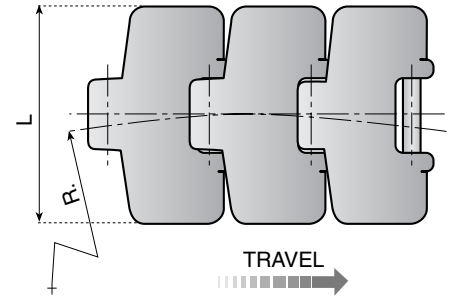
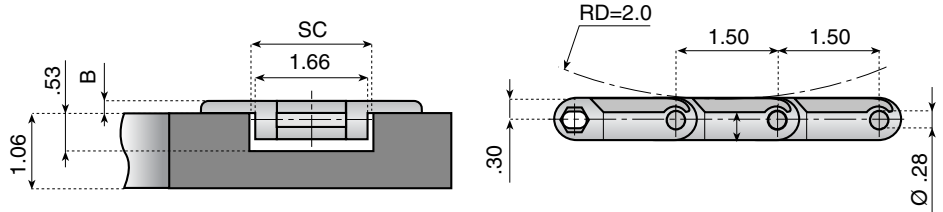
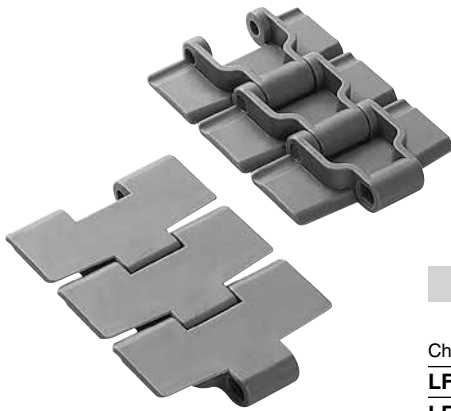

See page 146 for more information.

Material: "LF Brown" Low friction acetal with ferritic stainless steel pins.

Chain Reference	Part Number	Breaking Load (lbs.)	L (width)	B (thickness)	R Min.	SC	Weight (lbs. per ft.)
LF 880 M K325	11377M	1283	3-1/4	.16	18	1.77	.71
LF 880 M K450	11380M	1283	4-1/2	.16	20	1.77	.77
LF 879 M K325	11395M	1283	3-1/4	.19	18	1.77	.77
LF 879 M K450	11396M	1283	4-1/2	.19	20	1.77	.84

Material: "XPG Dark Grey" Very low friction acetal with ferritic stainless steel pins.

Chain Reference	Part Number	Breaking Load (lbs.)	L (width)	B (thickness)	R Min.	SC	Weight (lbs. per ft.)
XPG 880 M K325	11500MG	1239	3-1/4	.16	18	1.77	.71
XPG 880 M K450	11501MG	1239	4-1/2	.16	20	1.77	.77
XPG 879 M K325	11397MG	1239	3-1/4	.19	18	1.77	.77
XPG 879 M K450	11398MG	1239	4-1/2	.19	20	1.77	.84

Material: "NG Green" Our proprietary lowest friction PBT with ferritic stainless steel pins.

Chain Reference	Part Number	Breaking Load (lbs.)	L (width)	B (thickness)	R Min.	SC	Weight (lbs. per ft.)
NG 880 M K325	11195M	1170	3-1/4	.16	18	1.77	.71
NG 880 M K450	11197M	1170	4-1/2	.16	20	1.77	.77
NG 879 M K325	11198M	1170	3-1/4	.19	18	1.77	.77
NG 879 M K450	11421M	1170	4-1/2	.19	20	1.77	.84

Magnetic Side Flexing Plastic Chains

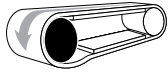

Drive Sprocket Options for 879 M, 880 M Chains

See all sprockets and idlers on pages 101-125



Machined Split

Molded Split

Shaft Sized Bore Dia.	Teeth or Equivalent	Part Number	Part Number
.71*	9	12910	-
1	9	12382S	-
1-1/4	9	12383S	-
1-7/16	9	12384S	-
1-1/2	9	12385S	-
.71*	10	12911	-
1	10	12386S	321001
1-1/4	10	12387S	321002
1-7/16	10	12388S	321003
1-1/2	10	12389S	321004
.71*	11	12912	-
1	11	12390S	-
1-1/4	11	12391S	-
1-7/16	11	12392S	-
1-1/2	11	12393S	-
.71*	12	12913	-
1	12	12394S	32400
1-1/4	12	12395S	32711
1-7/16	12	12396S	32401
1-1/2	12	12397S	32402

*Plain bore pilot hole. Not sized to a shaft.

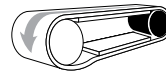

Idler Options for 879 M, 880 M Chains



Machined Split

Molded Split

Part Number	Part Number
-	-
121752S	-
121753S	-
121754S	-
121755S	-
-	-
121756S	321005
121757S	321006
121758S	321007
121759S	321008
-	-
121760S	-
121761S	-
121762S	-
121763S	-
-	-
121764S	32403
121765S	32404
121766S	32405
121767S	32406

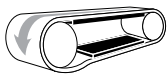

Track Options for 879 M, 880 M Chains K325

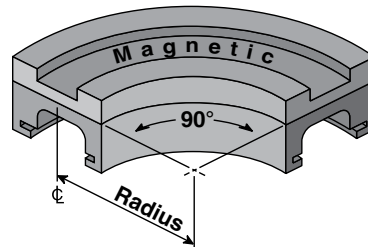

See all Magnetic Corner Tracks on pages 146-153

Number of Tracks	Total Width mm	Total Width inches	15°	30°	45°	60°	75°	90°
1	100	3.94	KMD.14.15.01.A	KMD.14.30.01.A	KMD.14.45.01.A	KMD.14.60.01.A	KMD.14.75.01.A	KMD.14.90.01.A
2	185	7.28	KMD.14.15.02.A	KMD.14.30.02.A	KMD.14.45.02.A	KMD.14.60.02.A	KMD.14.75.02.A	KMD.14.90.02.A
3	270	10.63	KMD.14.15.03.A	KMD.14.30.03.A	KMD.14.45.03.A	KMD.14.60.03.A	KMD.14.75.03.A	KMD.14.90.03.A
4	355	13.98	KMD.14.15.04.A	KMD.14.30.04.A	KMD.14.45.04.A	KMD.14.60.04.A	KMD.14.75.04.A	KMD.14.90.04.A

For additional number of tracks in a magnetic curve, see the chain track catalog section.

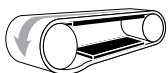

Track Options for 879 M, 880 M Chains K450 Series

Number of Tracks	Total Width mm	Total Width inches	15°	30°	45°	60°	75°	90°
1	129	5.08	KMD.23.15.01.A	KMD.23.30.01.A	KMD.23.45.01.A	KMD.23.60.01.A	KMD.23.75.01.A	KMD.23.90.01.A
2	246	9.69	KMD.23.15.02.A	KMD.23.30.02.A	KMD.23.45.02.A	KMD.23.60.02.A	KMD.23.75.02.A	KMD.23.90.02.A
3	363	14.29	KMD.23.15.03.A	KMD.23.30.03.A	KMD.23.45.03.A	KMD.23.60.03.A	KMD.23.75.03.A	KMD.23.90.03.A
4	480	18.90	KMD.23.15.04.A	KMD.23.30.04.A	KMD.23.45.04.A	KMD.23.60.04.A	KMD.23.75.04.A	KMD.23.90.04.A

For additional number of tracks in a magnetic curve, see the chain track catalog section.

Side Flexing Plastic Chains

882

Side Flexing Chains, Bevel Guides

- Heavy duty
- Large, flat surface
- Low coefficient of friction

Due to a larger hinge and pin size, plus a well balanced distribution of materials, the 882 bevel chain has excellent load carrying capacity, comparable with that of the 821 chain's double hinge design.

The standard widths include 10 inch sizes, making it compatible with the 821 series.

Standard Length: 10ft.
Pitches: 80

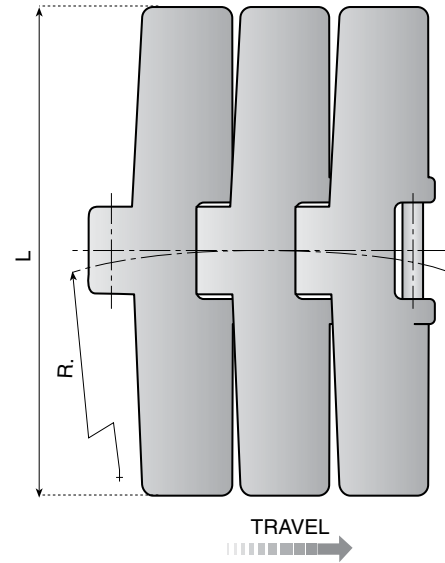
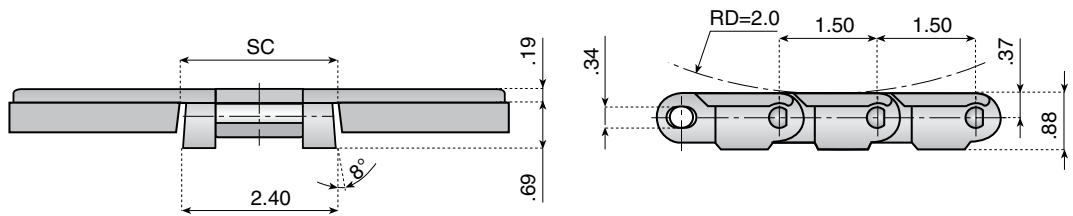
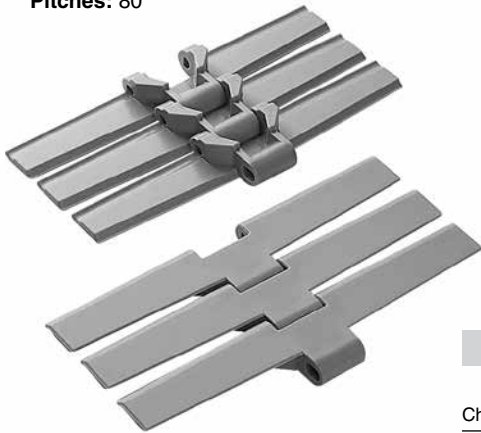

Material: "LF Brown" Low friction acetal with 304 stainless steel pins.

Chain Reference	Part Number	Breaking Load (lbs.)	L (width)	R Min.	SC Straight	SC Curved	Weight (lbs. per ft.)
LF 882 K450	11459	2248	4-1/2	24	2.44	2.28	1.30
LF 882 K750	11460	2248	7-1/2	24	2.44	2.28	1.60
LF 882 K1000	11461	2248	10	24	2.44	2.28	1.90

Material: "XPG Dark Grey" Very low friction acetal with 304 stainless steel pins.

Chain Reference	Part Number	Breaking Load (lbs.)	L (width)	R Min.	SC Straight	SC Curved	Weight (lbs. per ft.)
XPG 882 K450	11462G	2136	4-1/2	24	2.44	2.28	1.30
XPG 882 K750	11463G	2136	7-1/2	24	2.44	2.28	1.60
XPG 882 K1000	11464G	2136	10	24	2.44	2.28	1.90

Material: "NG Green" Our proprietary lowest friction PBT with 304 stainless steel pins.

Chain Reference	Part Number	Breaking Load (lbs.)	L (width)	R Min.	SC Straight	SC Curved	Weight (lbs. per ft.)
NG 882 K450	11480	2023	4-1/2	24	2.44	2.28	1.30
NG 882 K750	11481	2023	7-1/2	24	2.44	2.28	1.60
NG 882 K1000	11482	2023	10	24	2.44	2.28	1.90

Side Flexing Plastic Chains

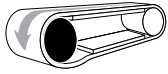

Drive Sprocket Options for 882 Chains



Machined Split



Molded Split

Shaft Sized Bore Dia.	Teeth or Equivalent	Part Number	Part Number
.71*	9	12914	-
1	9	12346S	-
1-1/4	9	12347S	-
1-7/16	9	12347SK	-
1-1/2	9	12348S	-
.71*	10	12915	-
1	10	12349S	321009
1-1/4	10	12350S	321010
1-7/16	10	12350SK	321011
1-1/2	10	12351S	321012
.71*	11	12916	-
1	11	12352S	-
1-1/4	11	12353S	-
1-7/16	11	12353SK	-
1-1/2	11	12354S	-
.71*	12	12917	-
1	12	12355S	32114
1-1/4	12	12356S	32115
1-7/16	12	12356SK	32116
1-1/2	12	12357S	32117

*Plain bore pilot hole. Not sized to a shaft.

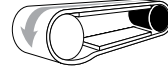

Idler Options for 882 Chains



Machined Split



Molded Split

Part Number	Part Number
-	-
121768S	-
121769S	-
121769SK	-
121770S	-
-	-
121771S	321013
121772S	321014
121772SK	321015
121773S	321016
-	-
121774S	-
121775S	-
121775SK	-
121776S	-
-	-
121777S	32119
121778S	32120
121778SK	32121
121779S	32122

See all sprockets and idlers on pages 101-125

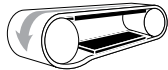

Track Options for 882 Chains

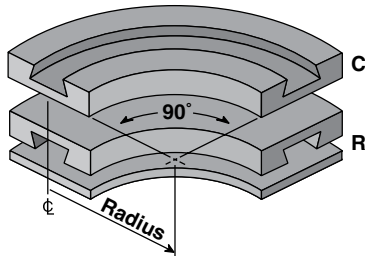

Corner Track

Part Number	Track Width	Carry or Return	Radius (inches)
VT-982-B-24-0450	5.0	Carry	24
VT-982-R-24-0450	5.0	Return	24
VT-982-B-24-0750	8.0	Carry	24
VT-982-R-24-0750	8.0	Return	24
VT-982-B-24-1000	10.5	Carry	24

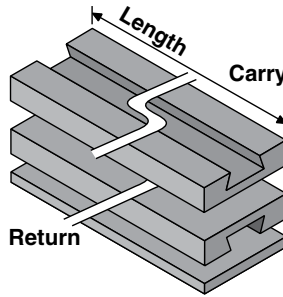

Straight Track

Part Number	Track Width	Carry or Return	Length (feet)
VT-982-B-S-0450-3	5.0	Carry	3
VT-982-B-S-0450-6	5.0	Carry	6
VT-982-B-S-0450-10	5.0	Carry	10
VT-982-B-S-0750-6	8.0	Carry	6
VT-982-B-S-0750-10	8.0	Carry	10
VT-982-B-S-1000-3	10.5	Carry	3
VT-982-B-S-1000-6	10.5	Carry	6
VT-982-B-S-1000-10	10.5	Carry	10
VT-982-R-S-1000-10	10.5	Return	10

See all ValuTrac modules on pages 130-145

Side Flexing Plastic Chains

882 TAB

Side Flexing Chains, TAB Guides

- Heavy duty
- Large, flat surface
- Low coefficient of friction

Due to a larger hinge and pin size, plus a well balanced distribution of materials, the 882 TAB chain has excellent load carrying capacity, comparable with that of the 821 chain's double hinge design.

Standard sizes are up to 12" wide, making it compatible with the 821 series. 882 TAB offers the largest conveying area in the side flexing flat top chain product line.

Standard Length: 10ft.
Pitches: 80

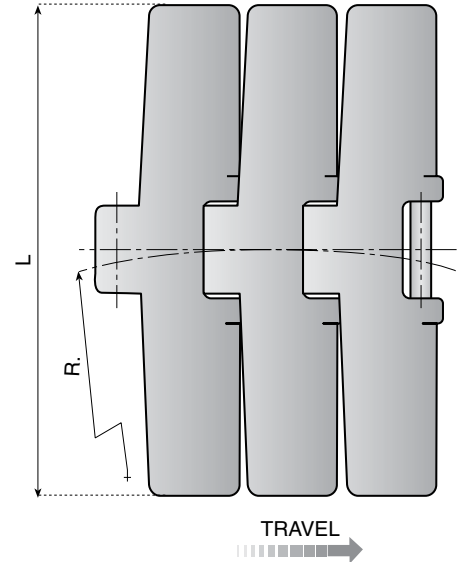
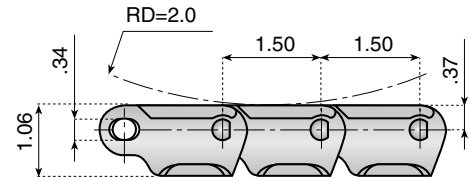
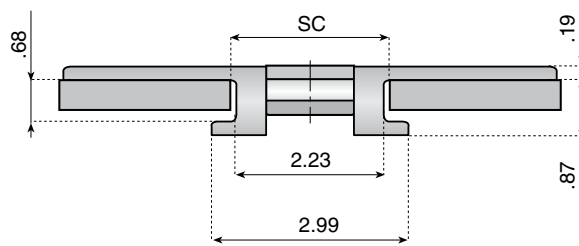

Material: "LF Brown" Low friction acetal with 304 stainless steel pins.

Chain Reference	Part Number	Breaking Load (lbs.)	L (width)	R Min.	SC Straight	SC Curved	Weight (lbs. per ft.)
LF 882 TAB K450	11040	2248	4-1/2	24	2.36	2.28	1.36
LF 882 TAB K750	11041	2248	7-1/2	24	2.36	2.28	1.65
LF 882 TAB K1000	11042	2248	10	24	2.36	2.28	1.93
LF 882 TAB K1200	11043	2248	12	24	2.36	2.28	2.29

Material: "XPG Dark Grey" Very low friction acetal with 304 stainless steel pins.

Chain Reference	Part Number	Breaking Load (lbs.)	L (width)	R Min.	SC Straight	SC Curved	Weight (lbs. per ft.)
XPG 882 TAB K450	11513G	2136	4-1/2	24	2.36	2.28	1.36
XPG 882 TAB K750	11514G	2136	7-1/2	24	2.36	2.28	1.65
XPG 882 TAB K1000	11515G	2136	10	24	2.36	2.28	1.93
XPG 882 TAB K1200	11516G	2136	12	24	2.36	2.28	2.29

Material: "NG Green" Our proprietary lowest friction PBT with 304 stainless steel pins.

Chain Reference	Part Number	Breaking Load (lbs.)	L (width)	R Min.	SC Straight	SC Curved	Weight (lbs. per ft.)
NG 882 TAB K450	11483	2023	4-1/2	24	2.36	2.28	1.36
NG 882 TAB K750	11484	2023	7-1/2	24	2.36	2.28	1.65
NG 882 TAB K1000	11485	2023	10	24	2.36	2.28	1.93
NG 882 TAB K1200	11486	2023	12	24	2.36	2.28	2.29

Side Flexing Plastic Chains

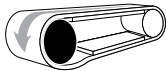

Drive Sprocket Options for 882 TAB Chains



Machined Split

Molded Split

Shaft Sized Bore Dia.	Teeth or Equivalent	Part Number	Part Number
.71*	9	12914	-
1	9	12346S	-
1-1/4	9	12347S	-
1-7/16	9	12347SK	-
1-1/2	9	12348S	-
.71*	10	12915	-
1	10	12349S	321009
1-1/4	10	12350S	321010
1-7/16	10	12350SK	321011
1-1/2	10	12351S	321012
.71*	11	12916	-
1	11	12352S	-
1-1/4	11	12353S	-
1-7/16	11	12353SK	-
1-1/2	11	12354S	-
.71*	12	12917	-
1	12	12355S	32114
1-1/4	12	12356S	32115
1-7/16	12	12356SK	32116
1-1/2	12	12357S	32117

*Plain bore pilot hole. Not sized to a shaft.

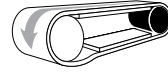

Idler Options for 882 TAB Chains



Machined Split

Molded Split

Part Number	Part Number
-	-
121768S	-
121769S	-
121769SK	-
121770S	-
-	-
121771S	321013
121772S	321014
121772SK	321015
121773S	321016
-	-
121774S	-
121775S	-
121775SK	-
121776S	-
-	-
121777S	32119
121778S	32120
121778SK	32121
121779S	32122

See all sprockets and idlers on pages 101-125

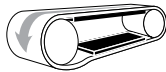

Track Options for 882 TAB Chains

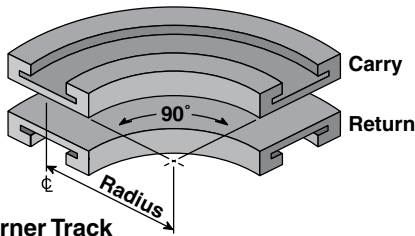

Corner Track

Part Number	Track Width	Radius (inches)
VT-982-T-24-0450	5.0	24
VT-982-T-24-0750	8.0	24
VT-982-T-24-1000	10.5	24
VT-982-T-24-1200	12.5	24

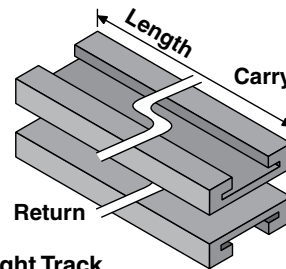

Straight Track

Part Number	Track Width	Length (feet)
VT-982-T-S-0450-3	5.0	3
VT-982-T-S-0450-6	5.0	6
VT-982-T-S-0450-10	5.0	10
VT-982-T-S-0750-3	8.0	3
VT-982-T-S-0750-6	8.0	6
VT-982-T-S-0750-10	8.0	10
VT-982-T-S-1000-3	10.5	3
VT-982-T-S-1000-6	10.5	6
VT-982-T-S-1000-10	10.5	10
VT-982-T-S-1200-6	12.5	6
VT-982-T-S-1200-10	12.5	10

See all ValuTrac modules on pages 130-145

831 VG

Straight Running Chains, Single Hinge, High Friction Surface

These chains are produced with high friction pads, and are ideal for use in the food and beverage industry where products are often conveyed on inclined and declined conveyors.

Low noise level, low coefficient of friction, and low horsepower requirements are the advantages of these chains. They provide an excellent flat surface and medium working load in a dry running environment.

Lines packaging PET bottle packs in heat shrink film, paper board boxes, or cans in heat shrink film, can also be fitted with these chains. Pharmaceutical industry applications include all general purpose conveying.

The added thickness (3/16 in.) of the 831 series top plate adds 20% more wear life, and simplifies conveyor design when matching with chain series: 821, 879, 882, 878.

These chains need a roller return track due to the friction pad extending across the full width of the plate.

Standard Length: 10ft.
Pitches: 80

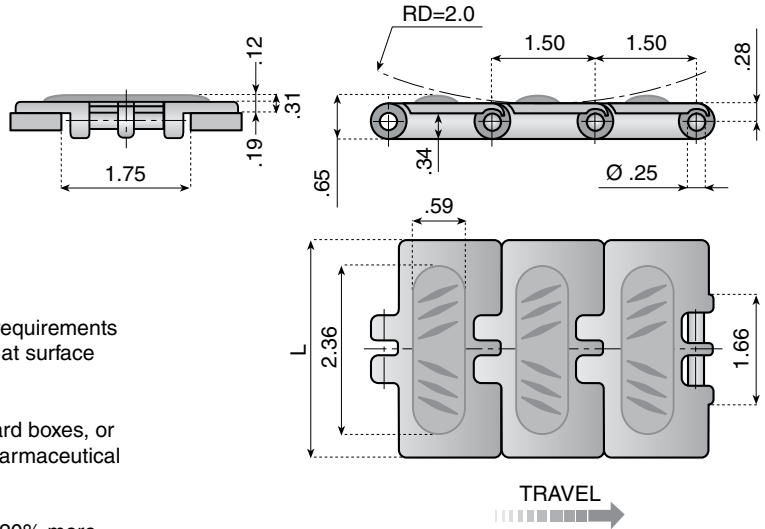

Material: "NGD Dark Grey" Our proprietary lowest friction PBT with 304 stainless steel pins. Water blue thermoplastic rubber pads.

Chain Reference	Part Number	Breaking Load (lbs.)	L (width)	Weight (lbs. per ft.)
NGD 831 K325 VG	11221	900	3-1/4	.94

Custom pad spacing available upon request. Pads are assembled per order based on customer requirements. Indicate distance between rubber pads when ordering.

Straight Running Plastic Chains

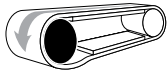

Drive Sprocket Options for 831 VG Chains



Machined Split



Molded Split

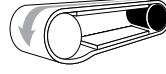

Idler Options for 831 VG Chains



Machined Split



Molded Split



Low-Friction Molded



Molded Split

Shaft Sized Bore Dia.	Teeth or Equivalent	Machined Split Part Number	Molded Split Part Number	Machined Split Part Number	Molded Split Part Number	Low-Friction Molded Part Number	Molded Split Part Number
.71*	19	12961	-	-	-	-	-
1	19	12924S	-	121147S	-	-	-
1-1/4	19	12925S	-	121148S	-	-	-
1-7/16	19	12926S	-	121149S	-	-	-
1-1/2	19	12927S	-	121150S	-	-	-
.71*	21	12962	-	-	-	-	-
1	21	12928S	32057	121151S	321095	32866	32077B
1-1/4	21	12929S	32058	121152S	321096	32867	32078B
1-7/16	21	12930S	32059	121153S	321097	32868	32079B
1-1/2	21	12931S	32060	121154S	321098	32869	32080B
.71*	23	12963	-	-	-	-	-
1	23	12932S	32104	121155S	321100	32874	-
1-1/4	23	12933S	32105	121156S	321101	32875	-
1-7/16	23	12934S	32106	121157S	321102	32876	-
1-1/2	23	12935S	32107	121158S	321103	32877	-
.71*	25	12964	-	-	-	-	-
1	25	12936S	32069	121159S	321105	32870	32081B
1-1/4	25	12937S	32070	121160S	321106	32871	32082B
1-7/16	25	12938S	32071	121161S	321107	32872	32083B
1-1/2	25	12939S	32072	121162S	321108	32873	32084B
.71*	27	121125	-	-	-	-	-
1	27	121126S	-	121163S	-	-	-
1-1/4	27	121127S	-	121164S	-	-	-
1-7/16	27	121128S	-	121165S	-	-	-
1-1/2	27	121129S	-	121166S	-	-	-

*Plain bore pilot hole. Not sized to a shaft.

See all sprockets and idlers on pages 101-125

Side Flexing Plastic Chains

878 TAB VG

Side Flexing Chains with High Friction Surface

These sideflexing chains are produced with high friction pads and are designed to articulate around a tight radius. Ideal for use in the food and beverage industry where products are often conveyed on inclined and declined conveyors.

Standard Length: 10ft.
Pitches: 80

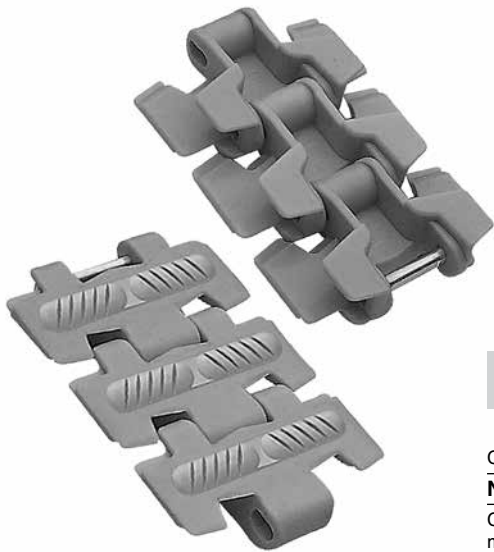

7 1/8 inch
side flexing radius!

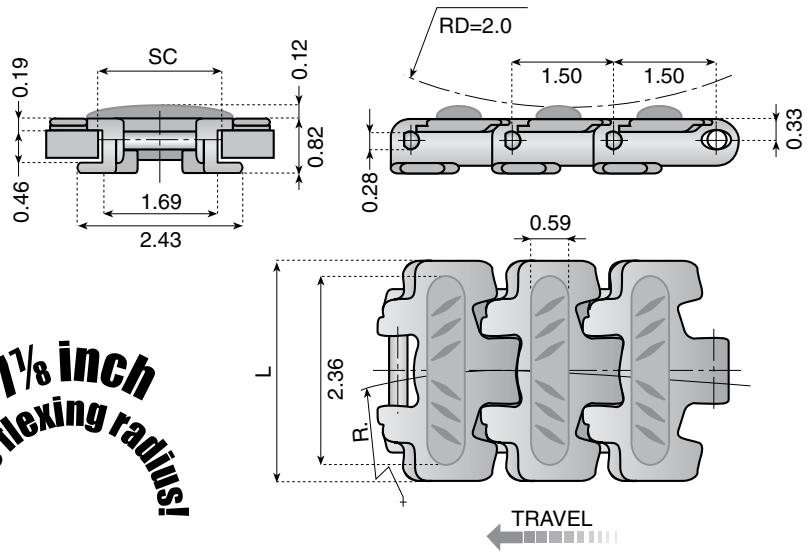

Material: "NGD Dark Grey" Our proprietary lowest friction PBT with 304 stainless steel pins.
Water blue thermoplastic rubber pads.

Chain Reference	Part Number	Breaking Load (lbs.)	L (width)	R Min.	SC Straight	SC Curved	Weight (lbs./ft.)
NGD 878 TAB K325 VG	11391	1124	3.25	7.87	1.81	1.77	0.60

Custom pad spacing available upon request. Pads are assembled per order based on customer requirements. Indicate distance between rubber pads when ordering.

Side Flexing Plastic Chains

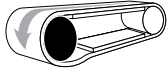

Drive Sprocket Options for 878 TAB VG Chains



Machined Split

Molded Split

Shaft Sized Bore Dia.	Teeth or Equivalent	Part Number	Part Number
.71*	9	12910	-
1	9	12382S	-
1-1/4	9	12383S	-
1-7/16	9	12384S	-
1-1/2	9	12385S	-
.71*	10	12911	-
1	10	12386S	321001
1-1/4	10	12387S	321002
1-7/16	10	12388S	321003
1-1/2	10	12389S	321004
.71*	11	12912	-
1	11	12390S	-
1-1/4	11	12391S	-
1-7/16	11	12392S	-
1-1/2	11	12393S	-
.71*	12	12913	-
1	12	12394S	32400
1-1/4	12	12395S	32711
1-7/16	12	12396S	32401
1-1/2	12	12397S	32402

*Plain bore pilot hole. Not sized to a shaft.

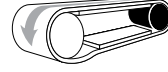

Idler Options for 878 TAB VG Chains



Machined Split

Molded Split

Part Number	Part Number
-	-
121752S	-
121753S	-
121754S	-
121755S	-
-	-
121756S	321005
121757S	321006
121758S	321007
121759S	321008
-	-
121760S	-
121761S	-
121762S	-
121763S	-
-	-
121764S	32403
121765S	32404
121766S	32405
121767S	32406

See all sprockets and idlers on pages 101-125

Improved Turning Disk Designs!

These chains can also use horizontal disks, ideal for numerous curves or alpine applications. See page 126 for complete details.

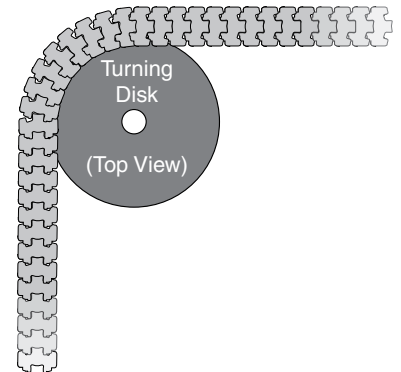

Side Flexing Plastic Chains

879 TAB VG

Side Flexing Chains with High Friction Surface

These sideflexing chains are produced with high friction pads and are designed to articulate around an 18 inch turn radius. Ideal for use in the food and beverage industry where products are often conveyed on inclined and declined conveyors.

Standard Length: 10ft.
Pitches: 80

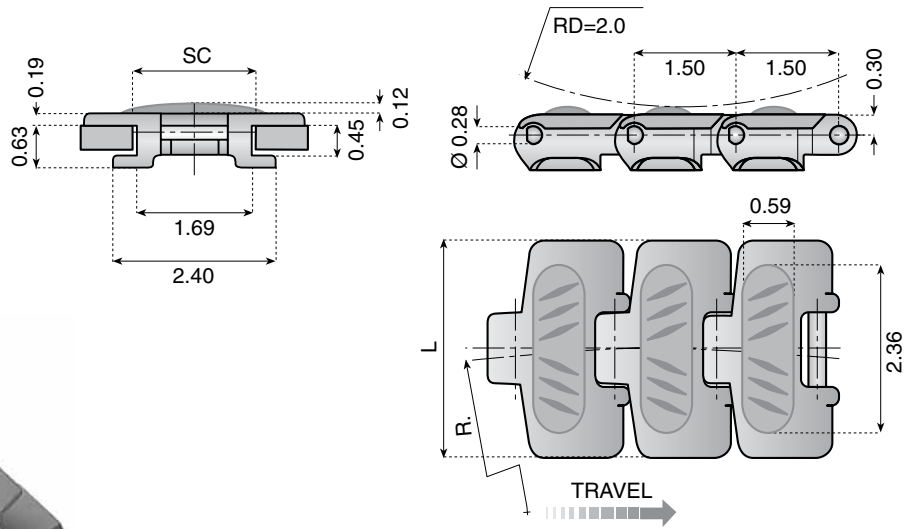
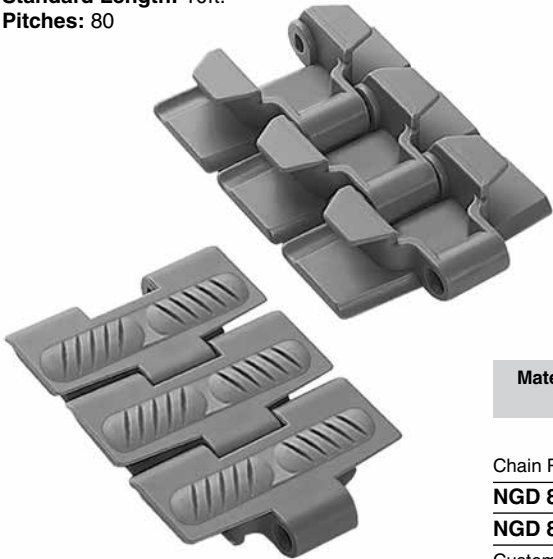

Material: "NGD Dark Grey" Our proprietary lowest friction PBT with 304 stainless steel pins.
Water blue thermoplastic rubber pads.

Chain Reference	Part Number	Breaking Load (lbs.)	L (width)	R Min.	SC Straight	SC Curved	Weight (lbs./ft.)
NGD 879 TAB K325 VG	11242	1124	3.25	18	1.81	1.77	0.94
NGD 879 TAB K450 VG	11245	1124	4.5	20	1.81	1.77	1.07

Custom pad spacing available upon request. Pads are assembled per order based on customer requirements. Indicate distance between rubber pads when ordering.

Side Flexing Plastic Chains

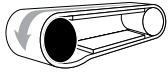

Drive Sprocket Options for 879 TAB VG Chains



Machined Split

Molded Split

Shaft Sized Bore Dia.	Teeth or Equivalent	Part Number	Part Number
.71*	9	12910	-
1	9	12382S	-
1-1/4	9	12383S	-
1-7/16	9	12384S	-
1-1/2	9	12385S	-
<hr/>			
.71*	10	12911	-
1	10	12386S	321001
1-1/4	10	12387S	321002
1-7/16	10	12388S	321003
1-1/2	10	12389S	321004
<hr/>			
.71*	11	12912	-
1	11	12390S	-
1-1/4	11	12391S	-
1-7/16	11	12392S	-
1-1/2	11	12393S	-
<hr/>			
.71*	12	12913	-
1	12	12394S	32400
1-1/4	12	12395S	32711
1-7/16	12	12396S	32401
1-1/2	12	12397S	32402

*Plain bore pilot hole. Not sized to a shaft.

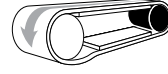

Idler Options for 879 TAB VG Chains



Machined Split

Molded Split

Part Number	Part Number
-	-
121752S	-
121753S	-
121754S	-
121755S	-
<hr/>	
-	-
121756S	321005
121757S	321006
121758S	321007
121759S	321008
<hr/>	
-	-
121760S	-
121761S	-
121762S	-
121763S	-
<hr/>	
-	-
121764S	32403
121765S	32404
121766S	32405
121767S	32406

See all sprockets and idlers on pages 101-125

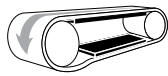

Track Options for 879 TAB VG Chains

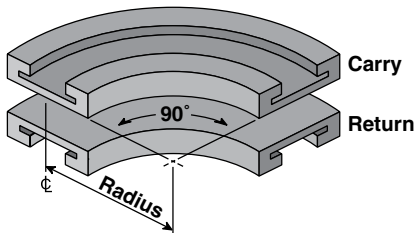

Corner Track

Part Number	Track Width	Radius (inches)
VT-980-T-18-0325	3.75	18
VT-980-T-24-0325	3.75	24
VT-980-T-24-0450	5.0	24

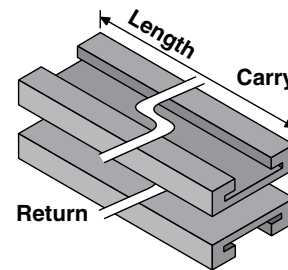

Straight Track

Part Number	Track Width	Length (feet)
VT-980-T-S-0325-3	3.75	3
VT-980-T-S-0325-6	3.75	6
VT-980-T-S-0325-10	3.75	10
VT-980-T-S-0450-3	5.0	3
VT-980-T-S-0450-6	5.0	6
VT-980-T-S-0450-10	5.0	10

See all ValuTrac modules on pages 130-145

Side Flexing Plastic Chains

882 TAB VG

Side Flexing Chains with High Friction Surface

These sideflexing chains offer a higher tensile strength than standard chains and are particularly suitable where heavier and larger products are conveyed. Ideal for use in the food and beverage industry where products are often conveyed on inclined and declined conveyors.

Standard Length: 10ft.
Pitches: 80

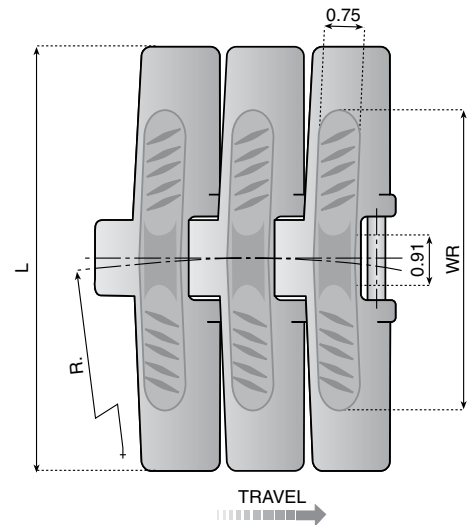
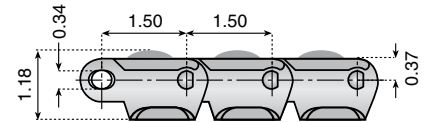
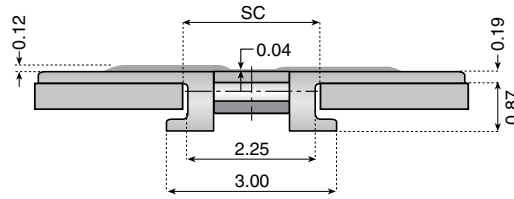

Material: "NGD Dark Grey" Our proprietary lowest friction PBT with 304 stainless steel pins.
Water blue thermoplastic rubber pads.

Chain Reference	Part Number	Breaking Load (lbs.)	L (width)	WR (width)	R Min.	SC Straight	SC Curved	Weight (lbs./ft.)
NGD 882 TAB K750 VG	11093	2023	7.50	5.31	24	2.36	2.28	1.58
NGD 882 TAB K1000 VG	11094	2023	10.00	7.50	24	2.36	2.28	1.78
NGD 882 TAB K1200 VG	11095	2023	12.00	10.00	24	2.36	2.28	1.95

Custom pad spacing available upon request. Pads are assembled per order based on customer requirements. Indicate distance between rubber pads when ordering.

Side Flexing Plastic Chains

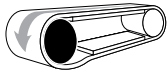

Drive Sprocket Options for 882 TAB VG Chains



Machined Split



Molded Split

Shaft Sized Bore Dia.	Teeth or Equivalent	Part Number	Part Number
.71*	9	12914	-
1	9	12346S	-
1-1/4	9	12347S	-
1-7/16	9	12347SK	-
1-1/2	9	12348S	-
.71*	10	12915	-
1	10	12349S	321009
1-1/4	10	12350S	321010
1-7/16	10	12350SK	321011
1-1/2	10	12351S	321012
.71*	11	12916	-
1	11	12352S	-
1-1/4	11	12353S	-
1-7/16	11	12353SK	-
1-1/2	11	12354S	-
.71*	12	12917	-
1	12	12355S	32114
1-1/4	12	12356S	32115
1-7/16	12	12356SK	32116
1-1/2	12	12357S	32117

*Plain bore pilot hole. Not sized to a shaft.

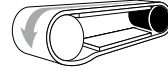

Idler Options for 882 TAB VG Chains



Machined Split



Molded Split

Part Number	Part Number
-	-
121768S	-
121769S	-
121769SK	-
121770S	-
-	-
121771S	321013
121772S	321014
121772SK	321015
121773S	321016
-	-
121774S	-
121775S	-
121775SK	-
121776S	-
-	-
121777S	32119
121778S	32120
121778SK	32121
121779S	32122

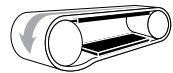

Track Options for 882 TAB VG Chains

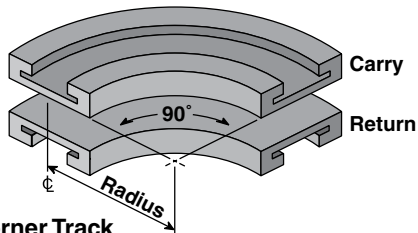

Corner Track

Part Number	Track Width	Radius (inches)
VT-982-T-24-0750	8.0	24
VT-982-T-24-1000	10.5	24
VT-982-T-24-1200	12.5	24

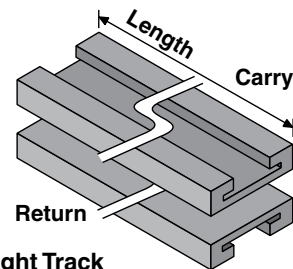

Straight Track

Part Number	Track Width	Length (feet)
VT-982-T-S-0750-3	8.0	3
VT-982-T-S-0750-6	8.0	6
VT-982-T-S-0750-10	8.0	10
VT-982-T-S-1000-3	10.5	3
VT-982-T-S-1000-6	10.5	6
VT-982-T-S-1000-10	10.5	10
VT-982-T-S-1200-6	12.5	6
VT-982-T-S-1200-10	12.5	10

See all sprockets and idlers on pages 101-125

See all ValuTrac modules on pages 130-145

Side Flexing Plastic Chains

878 TAB GS

Side Flexing Gripper Chains

- Exceptional durability
- Optimum performance
- Extremely low noise level
- Removable gripper

Gripper pads are utilized for a wide range of applications due to their unique mechanical properties. They offer resistance to laceration, abrasion, and other ambient influences.

Standard Length: 10ft.
Pitches: 80

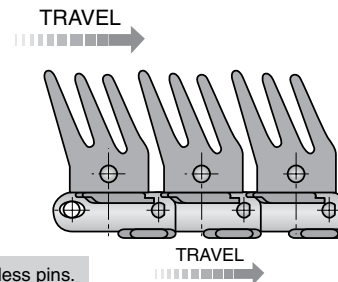
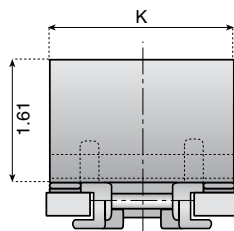
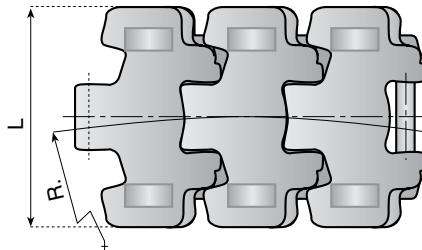
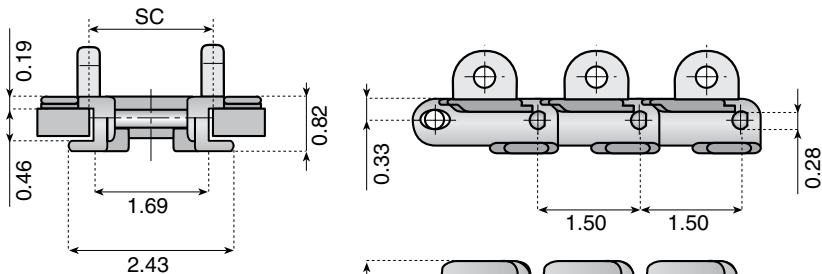

GS1 Style Light Applications

Material: "LFG Grey" Low friction acetal with thermoplastic gripper and 304 stainless pins.

Chain Reference	Part Number	Kit/Rubber and Pin	Rubber Part Number	Breaking Load (lbs.)	K	L (width)	R Min.	SC Straight	SC Curved	Weight (lbs./ft.)
LFG 878 TAB K325 GS1	11407	11736	11740	1349	3.23	3.25	7.87	1.81	1.77	3.12

GS2 Style Heavy Applications

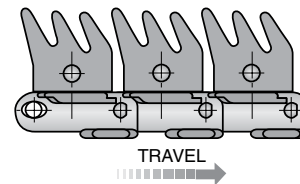
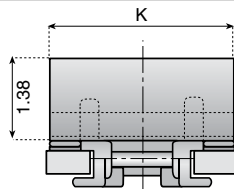

Chain Reference	Part Number	Kit/Rubber and Pin	Rubber Part Number	Breaking Load (lbs.)	K	L (width)	R Min.	SC Straight	SC Curved	Weight (lbs./ft.)
LFG 878 TAB K325 GS2	11408	11737	11742	1349	3.23	3.25	7.87	1.81	1.77	2.72

GS3 Style Special Applications

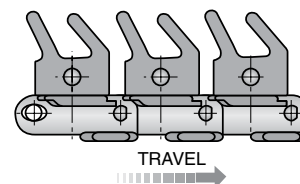
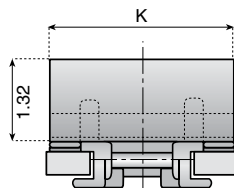

Chain Reference	Part Number	Kit/Rubber and Pin	Rubber Part Number	Breaking Load (lbs.)	K	L (width)	R Min.	SC Straight	SC Curved	Weight (lbs./ft.)
LFG 878 TAB K325 GS3	11409	11738	11744	1349	3.23	3.25	7.87	1.81	1.77	2.65

GS4 Style Special Applications

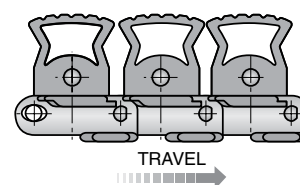
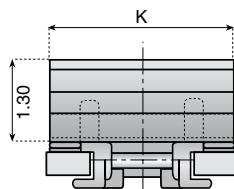

Chain Reference	Part Number	Kit/Rubber and Pin	Rubber Part Number	Breaking Load (lbs.)	K	L (width)	R Min.	SC Straight	SC Curved	Weight (lbs./ft.)
LFG 878 TAB K325 GS4	11404	11739	11746	1349	3.23	3.25	7.87	1.81	1.77	2.72

1 1/8 inch
side flexing radius!

Side Flexing Plastic Chains

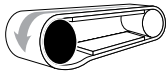

Drive Sprocket Options for 878 TAB GS Chains

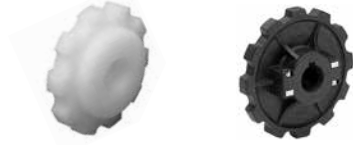

Machined Split

Molded Split

Shaft Sized Bore Dia.	Teeth or Equivalent	Part Number	Part Number
.71*	9	12910	-
1	9	12382S	-
1-1/4	9	12383S	-
1-7/16	9	12384S	-
1-1/2	9	12385S	-
<hr/>			
.71*	10	12911	-
1	10	12386S	321001
1-1/4	10	12387S	321002
1-7/16	10	12388S	321003
1-1/2	10	12389S	321004
<hr/>			
.71*	11	12912	-
1	11	12390S	-
1-1/4	11	12391S	-
1-7/16	11	12392S	-
1-1/2	11	12393S	-
<hr/>			
.71*	12	12913	-
1	12	12394S	32400
1-1/4	12	12395S	32711
1-7/16	12	12396S	32401
1-1/2	12	12397S	32402

*Plain bore pilot hole. Not sized to a shaft.

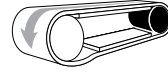

Idler Options for 878 TAB GS Chains



Machined Split

Molded Split

Part Number	Part Number
-	-
121752S	-
121753S	-
121754S	-
121755S	-
<hr/>	
-	-
121756S	321005
121757S	321006
121758S	321007
121759S	321008
<hr/>	
-	-
121760S	-
121761S	-
121762S	-
121763S	-
<hr/>	
-	-
121764S	32403
121765S	32404
121766S	32405
121767S	32406

See all sprockets and idlers on pages 101-125

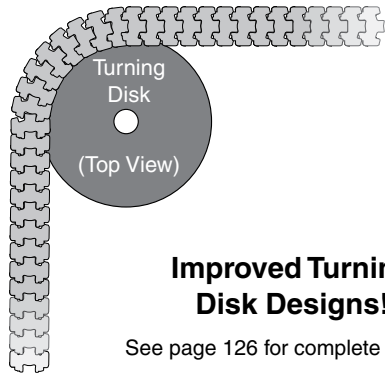

Improved Turning Disk Designs!

See page 126 for complete details.



Side Flexing 2-Piece Chains

1873 GS

Side Flexing Gripper Chains

Series 60 carbon or stainless steel roller chain, 3/4 in. pitch

- Exceptional durability
- Optimum performance
- Extremely low noise level
- Removable gripper
- Base roller chain with high load capability

Gripper pads are utilized for a wide range of applications due to their unique mechanical properties. They offer resistance to laceration, abrasion, and other ambient influences.

Standard Length: 10ft.
Pitches: 160

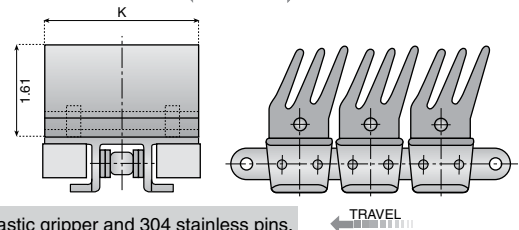
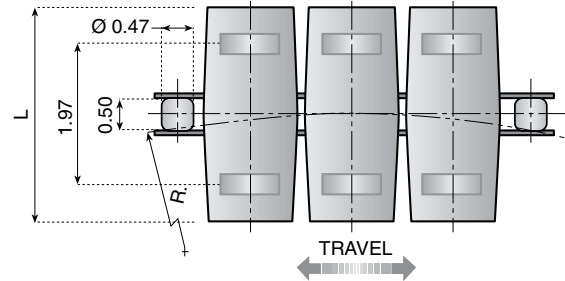
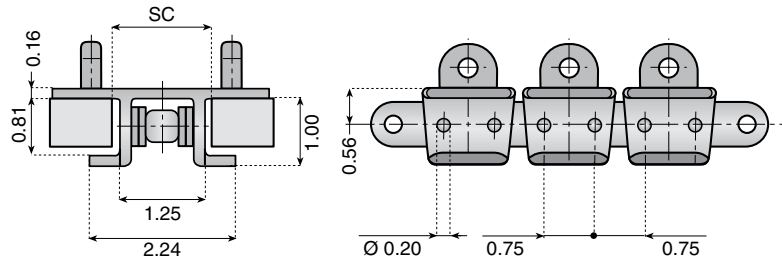

GS1 Style Light Applications

Material: "LFG Grey" Low friction acetal with thermoplastic gripper and 304 stainless pins.

Chain Reference	Part Number	Kit/Flight Rubber & Pin	Rubber Part Number	Breaking Load (lbs.)	K	L (width)	R Min.	SC Straight	SC Curved	Weight (lbs./ft.)
Carbon Steel LFG 1873 K325 GS1	11762	11730	11740	6070	3.23	3.25	15.0	1.31	1.38	3.12
Carbon Steel LFG 1873 K450 GS1	11766	11731	11741	6070	4.49	4.5	15.0	1.31	1.38	4.73
Stainless Steel LFG 1873 SS K325 GS1	11763	11730	11740	4721	3.23	3.25	15.0	1.31	1.38	3.12
Stainless Steel LFG 1873 SS K450 GS1	11767	11731	11741	4721	4.49	4.5	15.0	1.31	1.38	4.73

GS2 Style Heavy Applications

Material: "LFG Grey" Low friction acetal with thermoplastic gripper and 304 stainless pins.

Chain Reference	Part Number	Kit/Flight Rubber & Pin	Rubber Part Number	Breaking Load (lbs.)	K	L (width)	R Min.	SC Straight	SC Curved	Weight (lbs./ft.)
Carbon Steel LFG 1873 K325 GS2	11775	11732	11742	6070	3.23	3.25	15.0	1.31	1.38	2.72
Stainless Steel LFG 1873 SS K325 GS2	AA1100144	11732	11742	4721	3.23	3.25	15.0	1.31	1.38	2.72



Side Flexing 2-Piece Chains



GS4 Style Special Applications

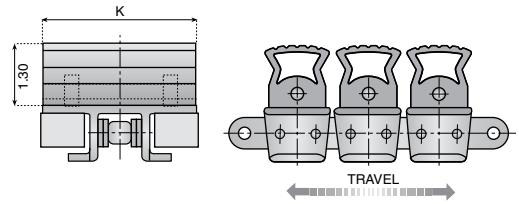

Material: "LFG Grey" Low friction acetal with thermoplastic gripper and 304 stainless pins.

Chain Reference	Part Number	Kit/Flight, Rubber & Pin	Rubber Part Number	Breaking Load (lbs.)	K	L (width)	R Min.	SC Straight	SC Curved	Weight (lbs./ft.)
Carbon Steel LFG 1873 K325 GS4	AA1100156	11728	11746	6070	3.23	3.25	15.0	1.31	1.38	2.72
Stainless Steel LFG 1873 SS K325 GS4	AA1100146	11728	11746	4721	3.23	3.25	15.0	1.31	1.38	2.72

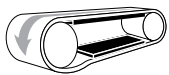

Track Options for 1873 GS Chains

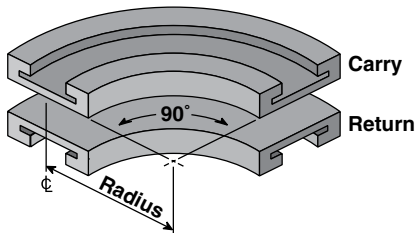

Corner Track

Part Number	Track Width	Radius (inches)
VT-973-T-18-0325	3.75	18
VT-973-T-24-0325	3.75	24
VT-973-T-24-0450	5.0	24

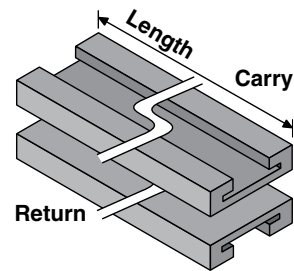

Straight Track

Part Number	Track Width	Length (feet)
VT-973-T-S-0325-3	3.75	3
VT-973-T-S-0325-6	3.75	6
VT-973-T-S-0325-10	3.75	10
VT-973-T-S-0450-3	5.0	3
VT-973-T-S-0450-6	5.0	6
VT-973-T-S-0450-10	5.0	10

See all ValuTrac modules on pages 130-145

Straight Running 2-Piece Chains

843

Straight Running Plate Top Chains

Series 40 carbon or stainless steel roller chain, 1/2 in. pitch

By combining the carrying capacity of a high quality base roller chain with the smoothness and flatness of thermoplastic flites, greater conveyor design flexibility, increased conveyor lengths and faster speeds are possible. Plate top chains offer the added benefits of:

- Small pitch
- Reduced sprocket diameter
- Easy maintenance
- Removable plastic flites
- High loads
- Ability to start under full load

Standard Length: 10ft.

Pitches: 240

Flites: 120

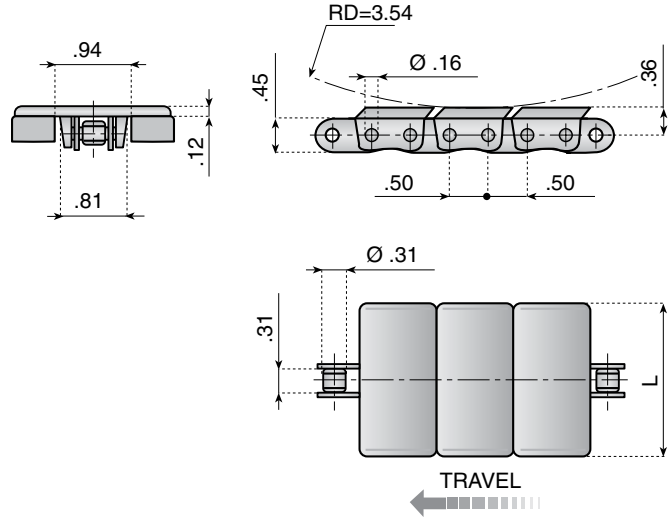

Material: "LFG Grey" Low friction acetal flites attached to steel roller chain.

Chain Reference	Part Number	L (width)	Weight (lbs. per ft.)
LF 843 K100	11593	1	.55
LF 843 K125	11720	1-1/4	.56
LF 843 K138	11614	1-3/8	.56
LF 843 K144	11615	1-7/16	.57
LF 843 K200	11616	2	.60
LF 843 K325	11617	3-1/4	.69

Material: "XPG Dark Grey" Very low friction acetal flites attached to steel roller chain.

Chain Reference	Part Number	L (width)	Weight (lbs. per ft.)
XPG 843 K100	11594G	1	.55
XPG 843 K125	11721G	1-1/4	.56
XPG 843 K138	11517G	1-3/8	.56
XPG 843 K144	11595G	1-7/16	.57
XPG 843 K200	11518G	2	.60
XPG 843 K325	11519G	3-1/4	.69

Material: "LFG Grey" Low friction acetal flites attached to steel roller chain.

Chain Reference	Part Number	L (width)	Weight (lbs. per ft.)
LF 843 SS K100	11597	1	.55
LF 843 SS K138	11644	1-3/8	.56
LF 843 SS K144	11645	1-7/16	.57
LF 843 SS K200	11646	2	.60
LF 843 SS K325	11647	3-1/4	.69

Material: "XPG Dark Grey" Very low friction acetal flites attached to stainless steel roller chain.

Chain Reference	Part Number	L (width)	Weight (lbs. per ft.)
XPG 843 SS K100	11598G	1	.55
XPG 843 SS K125	11724G	1-1/4	.56
XPG 843 SS K138	11520G	1-3/8	.56
XPG 843 SS K144	11599G	1-7/16	.57
XPG 843 SS K200	11521G	2	.60
XPG 843 SS K325	11522G	3-1/4	.69

863

Straight Running Plate Top Chains Series 60 carbon or stainless steel roller chain, 3/4 in. pitch

By combining the carrying capacity of a high quality base roller chain with the smoothness and flatness of thermo-plastic flites, greater conveyor design flexibility, increased conveyor lengths and faster speeds are possible. Plate top chains offer the added benefits of:

- Easy maintenance
- Removable plastic flites
- Very high loads
- Ability to start under full load

Standard Length: 10ft.
Pitches: 160
Flites: 80

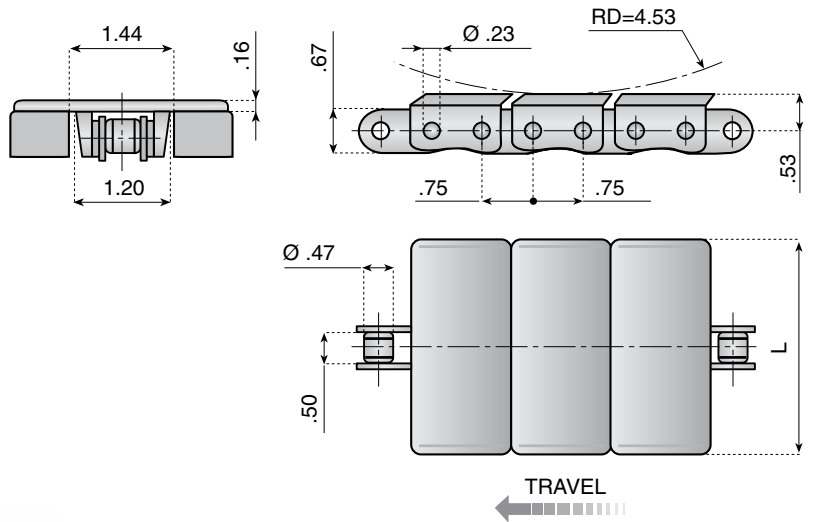

Material: "LFG Grey" Low friction acetal flites attached to steel roller chain.

Chain Reference	Part Number	L (width)	Weight (lbs. per ft.)
LF 863 K325	11622	3-1/4	1.41
LF 863 K450	11623	4-1/2	1.50
LF 863 K600	11624	6	1.70
LF 863 K750	11625	7-1/2	1.80

Material: "XP Dark Grey" Very low friction acetal flites attached to steel roller chain.

Chain Reference	Part Number	L (width)	Weight (lbs. per ft.)
XPG 863 K325	11523G	3-1/4	1.41
XPG 863 K600	11525G	6	1.70
XPG 863 K750	11526G	7-1/2	1.80

Material: "LFG Grey" Low friction acetal flites attached to steel roller chain.

Chain Reference	Part Number	L (width)	Weight (lbs. per ft.)
LF 863 SS K325	11652	3-1/4	1.41
LF 863 SS K450	11653	4-1/2	1.50
LF 863 SS K600	11654	6	1.70
LF 863 SS K750	11655	7-1/2	1.80

Material: "XP Dark Grey" Very low friction acetal flites attached to stainless steel roller chain.

Chain Reference	Part Number	L (width)	Weight (lbs. per ft.)
XPG 863 SS K325	11527G	3-1/4	1.41
XPG 863 SS K450	11528G	4-1/2	1.50
XPG 863 SS K600	11529G	6	1.70
XPG 863 SS K750	11530G	7-1/2	1.80

Side Flexing 2-Piece Chains

1843

Side Flexing, Overlapping Plate Top Chains

Series 40 carbon or stainless steel roller chain, 1/2 in. pitch

The 1843 series chain offers a continuous, flat conveying surface by combining the carrying capacity of a high quality sidebow base roller chain with snap-on thermoplastic flites. The tab shoes on the flites retain the chain to the track on both the carrying and return sections. This allows for increased conveyor lengths and faster speeds.

- Higher loads
- Longer conveyors
- Easy maintenance
- Flites removable

Standard Length: 10ft.
Pitches: 240
Flites: 120

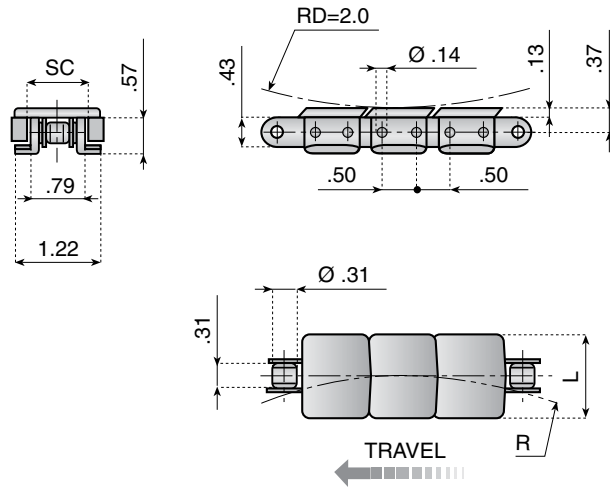

Material: "LF Brown" Low friction acetal flites attached to steel roller chain.						
Chain Reference	Part Number	L (width)	R Min.	SC	Weight (lbs. per ft.)	
LF 1843 K125	11543	1-1/4	10	.88	.50	
LF 1843 K200	11429	2	10	.88	.60	
Material: "XPG Dark Grey" Very low friction acetal flites attached to steel roller chain.						
Chain Reference	Part Number	L (width)	R Min.	SC	Weight (lbs. per ft.)	
XPG 1843 K125	11544G	1-1/4	10	.88	.50	
XPG 1843 K200	11430G	2	10	.88	.60	

Material: "LF Brown" Low friction acetal flites attached to stainless steel roller chain.						
Chain Reference	Part Number	L (width)	R Min.	SC	Weight (lbs. per ft.)	
LF 1843 SS K125	11545	1-1/4	10	.88	.50	
LF 1843 SS K200	11433	2	10	.88	.60	
Material: "XPG Dark Grey" Very low friction acetal flites attached to stainless steel roller chain.						
Chain Reference	Part Number	L (width)	R Min.	SC	Weight (lbs. per ft.)	
XPG 1843 SS K125	11546G	1-1/4	10	.88	.50	
XPG 1843 SS K200	11434G	2	10	.88	.60	

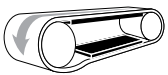

Track Options for 1843 Chains

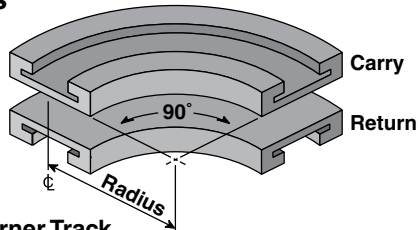

Corner Track

Part Number	Track Width	Radius (inches)
VT-943-T-10-0150	2	10
VT-943-T-18-0150	2	18
VT-943-T-24-0150	2	24

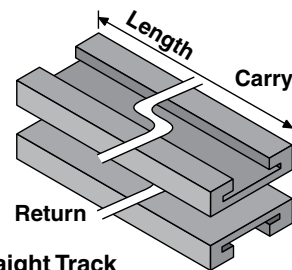

Straight Track

Part Number	Track Width	Length (feet)
VT-943-T-S-0150-3	2	3
VT-943-T-S-0150-6	2	6
VT-943-T-S-0150-10	2	10

1863

Side Flexing, Overlapping Plate Top Chains

Series 60 carbon or stainless steel roller chain, 3/4 in. pitch

The 1863 series is a further development of the well known 1873 series chain. It has the mechanical characteristics of the 1873 series, offering high speed, longer conveyors and the ability to start under load. Additional features include:

- Overlapping flites to facilitate the conveying of instable products.
- Reduced gap between flites to assure better product stability.
- No more pinching of products in the curve section.
- Improved safety because of the reduced flites gap on both the straight and curved sections of the conveyor.
- Interchangeable with 1873 series.

Standard Length: 10ft.

Pitches: 160

Flites: 80

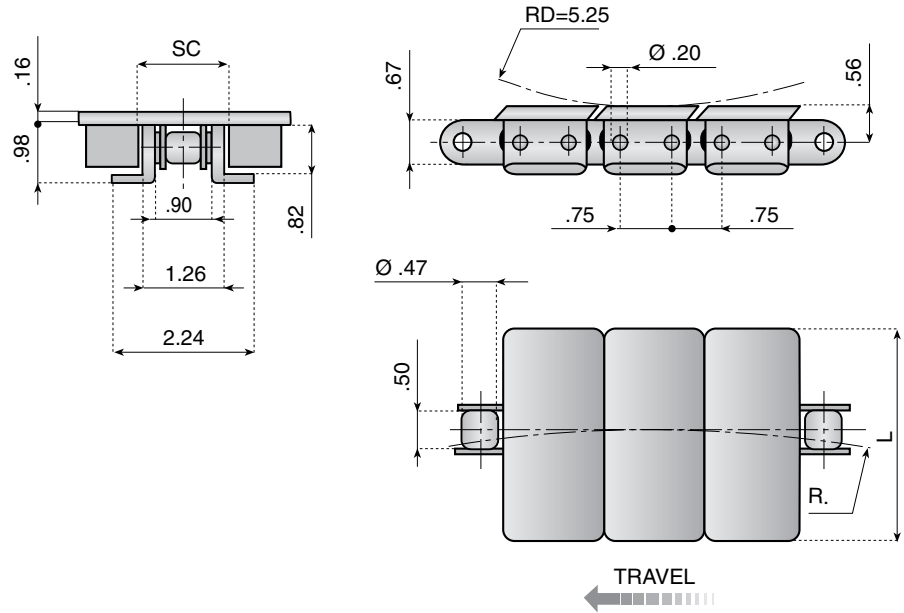

		Material: "LF Brown" Low friction acetal flites attached to steel roller chain.					
Carbon Steel	Chain Reference	Part Number	L (width)	R Min.	SC Straight	SC Curved	Weight (lbs. per ft.)
		LF 1863 K225	11547	2-1/4	15	1.31	1.38
		Material: "XP Dark Grey" Very low friction acetal flites attached to steel roller chain.					
Carbon Steel	Chain Reference	Part Number	L (width)	R Min.	SC Straight	SC Curved	Weight (lbs. per ft.)
		XPG 1863 K225	11552G	2-1/4	15	1.31	1.38
		Material: "LF Brown" Low friction acetal flites attached to stainless steel roller chain.					
Stainless Steel	Chain Reference	Part Number	L (width)	R Min.	SC Straight	SC Curved	Weight (lbs. per ft.)
		LF 1863 SS K225	11557	2-1/4	15	1.31	1.38
		Material: "XP Dark Grey" Very low friction acetal flites attached to stainless steel roller chain.					
Stainless Steel	Chain Reference	Part Number	L (width)	R Min.	SC Straight	SC Curved	Weight (lbs. per ft.)
		XPG 1863 SS K225	11562G	2-1/4	15	1.31	1.38

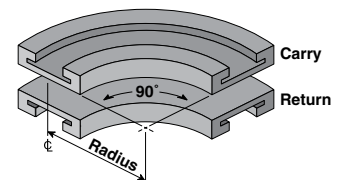

ValuTrac modular chain guides are available for this track. See page 130.

Side Flexing 2-Piece Chains

1873

Side Flexing, Overlapping Plate Top Chains

Series 60 carbon or stainless steel roller chain, 3/4 in. pitch

The 1873 series chain combines the carrying capacity of a high quality sidebow roller chain with snap-on thermoplastic flites. The tab shoes on the flites retain the chain to the track on both the carrying and return sections. This allows for increased conveyor lengths and faster speeds.

- Very high loads
- Longer conveyors
- Easy maintenance
- Removable flites
- Lower noise

Standard Length: 10ft.

Pitches: 160

Flites: 80

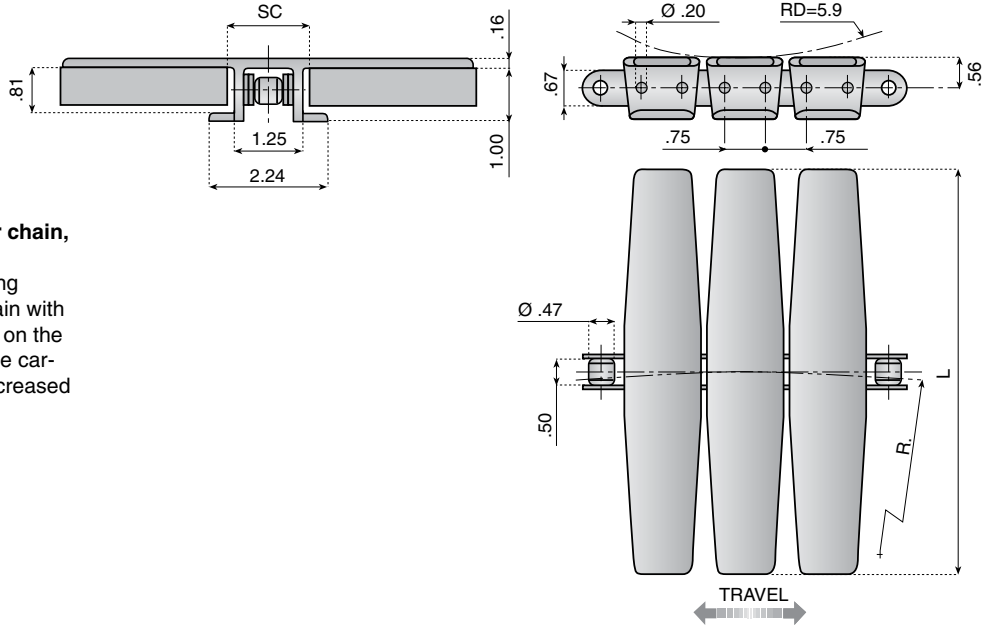

		Material: "LF Brown" Low friction acetal flites attached to steel roller chain.				
Chain Reference	Part Number	L (width)	R Min.	SC Straight	SC Curved	Weight (lbs. per ft.)
LF 1873 K225	11633	2-1/4	15	1.31	1.38	1.34
LF 1873 K325	11634	3-1/4	15	1.31	1.38	1.41
LF 1873 K450	11635	4-1/2	15	1.31	1.38	1.50
LF 1873 K600	11636	6	20	1.31	1.38	1.61
LF 1873 K750	11637	7-1/2	20	1.31	1.38	1.75
LF 1873 K1000	11638	10	20	1.31	1.38	1.88
LF 1873 K1200	11639	12	24	1.31	1.38	2.02
		Material: "XPG Dark Grey" Very low friction acetal flites attached to steel roller chain.				
Chain Reference	Part Number	L (width)	R Min.	SC Straight	SC Curved	Weight (lbs. per ft.)
XPG 1873 K225	11706G	2-1/4	15	1.31	1.38	1.34
XPG 1873 K325	11531G	3-1/4	15	1.31	1.38	1.41
XPG 1873 K450	11532G	4-1/2	15	1.31	1.38	1.50
XPG 1873 K600	11533G	6	20	1.31	1.38	1.61
XPG 1873 K750	11534G	7-1/2	20	1.31	1.38	1.75
XPG 1873 K1000	11535G	10	20	1.31	1.38	1.88
XPG 1873 K1200	11536G	12	24	1.31	1.38	2.02
		Material: "LF Brown" Low friction acetal flites attached to stainless steel roller chain.				
Chain Reference	Part Number	L (width)	R Min.	SC Straight	SC Curved	Weight (lbs. per ft.)
LF 1873 SS K225	11663	2-1/4	15	1.31	1.38	1.34
LF 1873 SS K325	11664	3-1/4	15	1.31	1.38	1.41
LF 1873 SS K450	11665	4-1/2	15	1.31	1.38	1.50
LF 1873 SS K600	11666	6	20	1.31	1.38	1.61
LF 1873 SS K750	11667	7-1/2	20	1.31	1.38	1.75
LF 1873 SS K1000	11668	10	20	1.31	1.38	1.88
LF 1873 SS K1200	11669	12	24	1.31	1.38	2.02
		Material: "XPG Dark Grey" Very low friction acetal flites attached to stainless steel roller chain.				
Chain Reference	Part Number	L (width)	R Min.	SC Straight	SC Curved	Weight (lbs. per ft.)
XPG 1873 SS K225	11708G	2-1/4	15	1.31	1.38	1.34
XPG 1873 SS K325	11537G	3-1/4	15	1.31	1.38	1.41
XPG 1873 SS K450	11538G	4-1/2	15	1.31	1.38	1.50
XPG 1873 SS K600	11539G	6	20	1.31	1.38	1.61
XPG 1873 SS K750	11540G	7-1/2	20	1.31	1.38	1.75
XPG 1873 SS K1000	11541G	10	20	1.31	1.38	1.88
XPG 1873 SS K1200	11542G	12	24	1.31	1.38	2.02

Carbon Steel

Stainless Steel

Side Flexing 2-Piece Chains

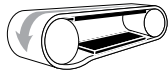

Track Options for 1873 Chains

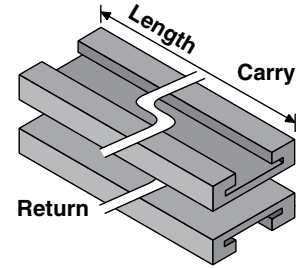
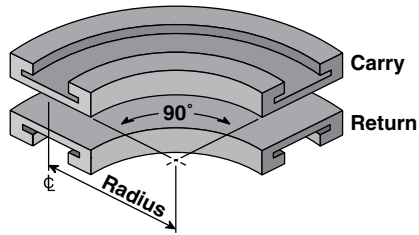

Corner Track

Part Number	Track Width	Radius (inches)
VT-973-T-18-0325	3.75	18
VT-973-T-24-0325	3.75	24
VT-973-T-24-0450	5.0	24
VT-973-T-24-0600	6.5	24
VT-973-T-18-0750	8.0	18
VT-973-T-24-0750	8.0	24

Straight Track

Part Number	Track Width	Length (feet)
VT-973-T-S-0325-3	3.75	3
VT-973-T-S-0325-6	3.75	6
VT-973-T-S-0325-10	3.75	10
VT-973-T-S-0450-3	5.0	3
VT-973-T-S-0450-6	5.0	6
VT-973-T-S-0450-10	5.0	10
VT-973-T-S-0600-10	6.5	10
VT-973-T-S-0750-6	8.0	6
VT-973-T-S-0750-10	8.0	10

See all ValuTrac modules on pages 130-145

Multiflex Chains

1700

Multiflex Chains

Used for conveying milk cartons in the dairy industry, or for elevating or lowering products with the possibility of accumulation. Also used in the preserving and mechanical industries. Additional features include:

- Multi-directional flexibility
- Horizontal or incline/decline
- Small sideflexing radius
- High working load
- Quality construction
- Long wear life
- Low coefficient of friction

Standard Length: 10ft.
Pitches: 61

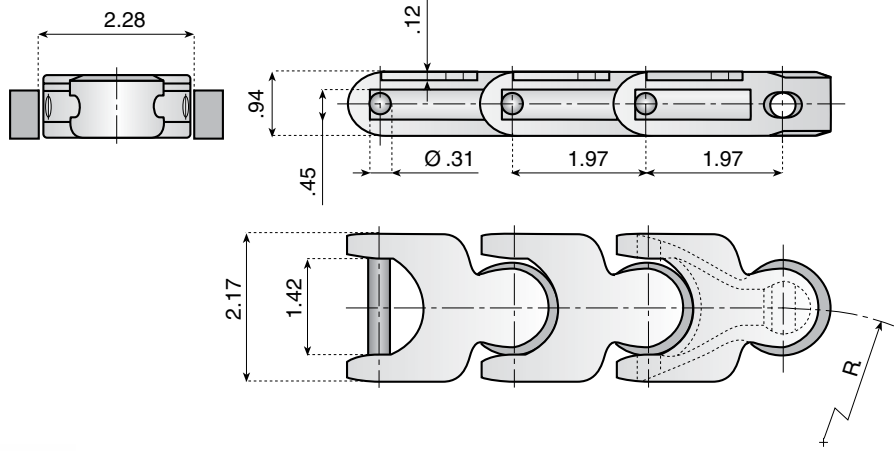

Material: White acetal with stainless steel pins.

Chain Reference	Part Number	Min. Radius	Breaking Load (lbs.)	Weight (lbs. per ft.)
W-1700	11951	4.92	1910	.84

Material: "LF White" Low friction acetal with stainless steel pins.

LFW-1700	11953	4.92	1910	.84
-----------------	--------------	-------------	-------------	------------

1702

Multiflex Chains

Standard Length: 10ft.
Pitches: 61

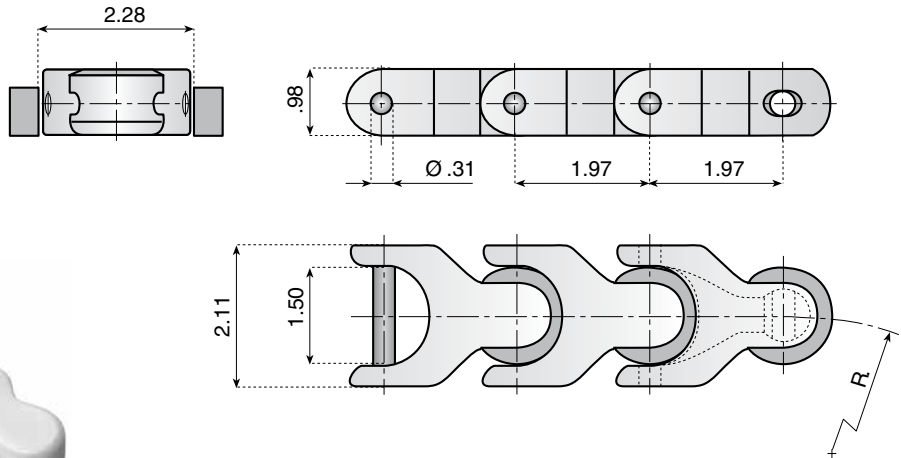

Material: "LF White" Low friction acetal with stainless steel pins.

LFW-1702	11955	5.51	2360	.94
-----------------	--------------	-------------	-------------	------------

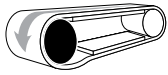

Drive Sprocket Options for 1700, 1702 Multiflex Chains



Machined Split

Shaft Sized Bore Dia.	Teeth or Equivalent	Part Number
.79*	8	12730
1	8	32731
1-1/4	8	32732
1-7/16	8	32733
1-1/2	8	32734
.79*	10	12745
1	10	32746
1-1/4	10	32747
1-7/16	10	32748
1-1/2	10	32749
.79*	13	12750
1	13	32751
1-1/4	13	32752
1-7/16	13	32753
1-1/2	13	32754

*Plain bore pilot hole. Not sized to a shaft.

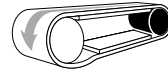

Idler Options for 1700, 1702 Multiflex Chains



Machined Split

Part Number
-
32736
32737
32738
32739
-
32741
32742
32743
32744
-
32756
32757
32758
32759

See all sprockets and idlers on pages 101-125

Improved Turning Disk Designs!

These chains can also use horizontal disks, ideal for numerous curves or alpine applications. See page 126 for complete details.

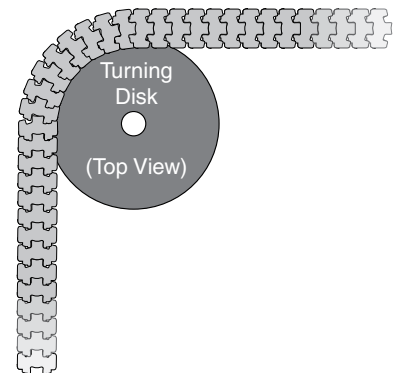

Multiflex Chains

1701 TAB

Multiflex Chains

Used for conveying milk cartons in the dairy industry, or for elevating or lowering products with the possibility of accumulation. Also used in the preserving and mechanical industries. Additional features include:

- Multi-directional flexibility
- Horizontal or incline/decline
- Small sideflexing radius
- High working load
- Quality construction
- Long wear life
- Low coefficient of friction

Standard Length: 10ft.
Pitches: 61

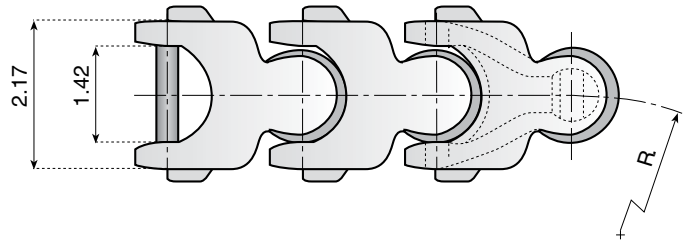
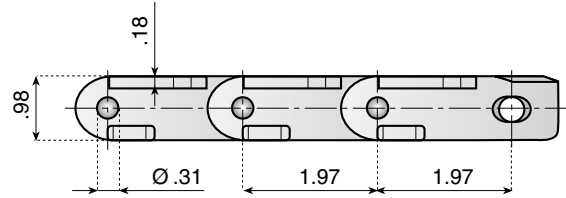
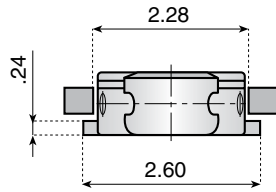

Material: "LF Brown" Low friction acetal with stainless steel pins.

Chain Reference	Part Number	Min. Radius	Breaking Load (lbs.)	Weight (lbs. per ft.)
LF-1701 TAB	11956	5.31	1910	.97

1701 TAB OP

Multiflex Chains

Standard Length: 10ft.
Pitches: 61

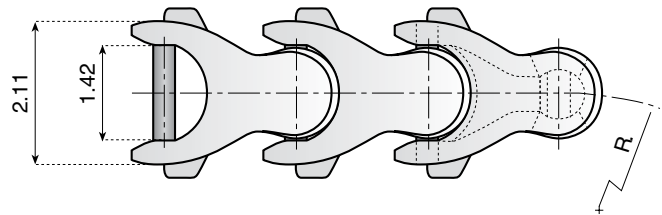
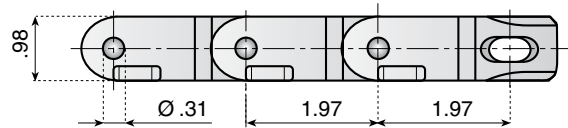
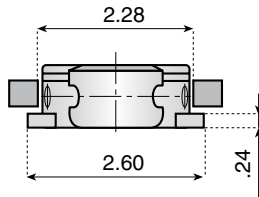

Material: "LF Brown" Low friction acetal with stainless steel pins.

Chain Reference	Part Number	Min. Radius	Breaking Load (lbs.)	Weight (lbs. per ft.)
LF-1701 TAB OP	11958	4.92	1910	.94

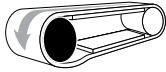

Drive Sprocket Options for 1701 TAB, 1701 TAB OP Multiflex Chains



Machined Split

Shaft Sized Bore Dia.	Teeth or Equivalent	Part Number
.79*	8	12730
1	8	32731
1-1/4	8	32732
1-7/16	8	32733
1-1/2	8	32734
.79*	10	12745
1	10	32746
1-1/4	10	32747
1-7/16	10	32748
1-1/2	10	32749
.79*	13	12750
1	13	32751
1-1/4	13	32752
1-7/16	13	32753
1-1/2	13	32754

*Plain bore pilot hole. Not sized to a shaft.

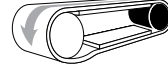

Idler Options for 1701 TAB, 1701 TAB OP Multiflex Chains



Machined

See all sprockets and idlers on pages 101-125

Part Number
-
32736
32737
32738
32739
-
32741
32742
32743
32744
-
32756
32757
32758
32759

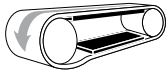

Track Options for 1701 TAB Chains

See all ValuTrac modules on pages 130-145

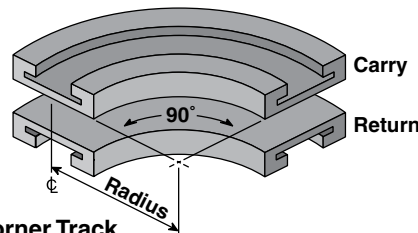

Corner Track

Part Number	Track Width	Radius (inches)
VT-901-T-24-0209	3.25	24

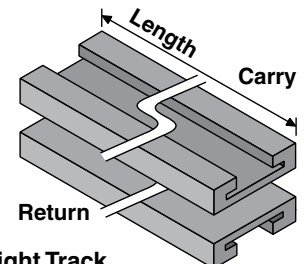

Straight Track

Part Number	Track Width	Length (feet)
VT-901-T-S-0209-3	3.25	3
VT-901-T-S-0209-6	3.25	6
VT-901-T-S-0209-10	3.25	10

Improved Turning Disk Designs!

These chains can also use horizontal disks, ideal for numerous curves or alpine applications. See page 126 for complete details.

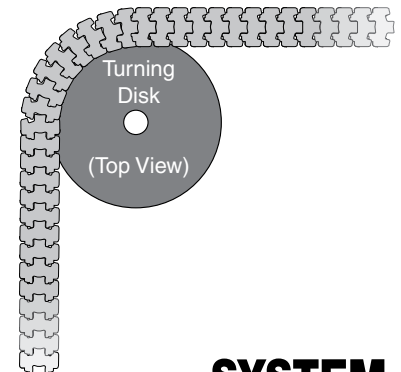

Case/Crate Conveyor Chains

CC 600

Case/Crate Conveyor Chains

These chains transport plastic crates, or can be used for general purpose conveying applications. They feature high strength, curving radius capability, uniform matte finish, and high wear resistance.

Standard Length: 10ft.

Pitches: 48

See page 125 for compatible sprockets.

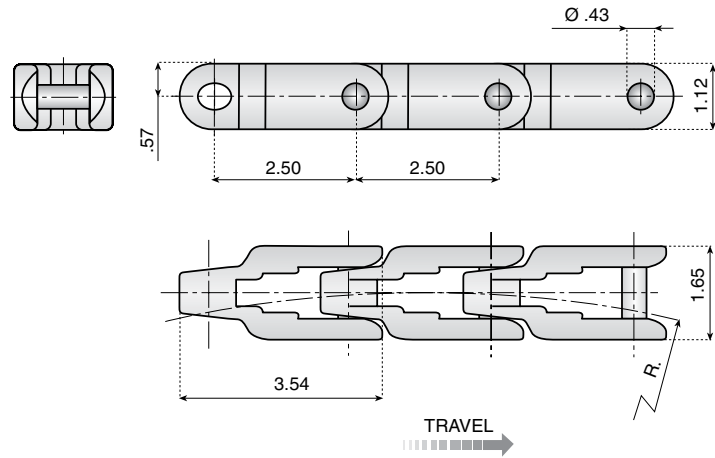

Material: White acetal with stainless steel pins.

Chain Reference	Part Number	Min. Radius	Breaking Load (lbs.)	Weight (lbs. per ft.)
CC-600	11007	27.55	3147	.89

CC 600 TAB

Case/Crate Conveyor Chains

Standard Length: 10ft.

Pitches: 48

See page 125 for compatible sprockets.

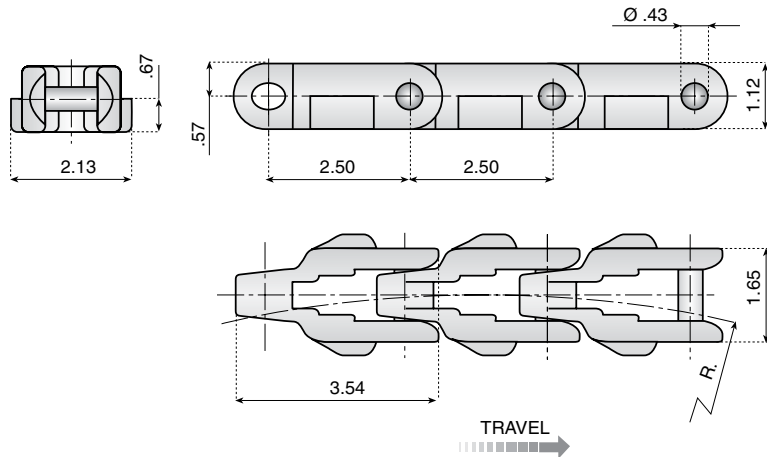

Material: White acetal with stainless steel pins.

Chain Reference	Part Number	Min. Radius	Breaking Load (lbs.)	Weight (lbs. per ft.)
CC-600 TAB	11009	27.55	3147	1.0

CC 1400

Case/Crate Conveyor Chains

These chains transport plastic crates, or can be used for general purpose conveying applications. They feature high strength, curving radius capability, uniform matte finish, and very high wear resistance.

Standard Length: 10ft. Pitches: 37

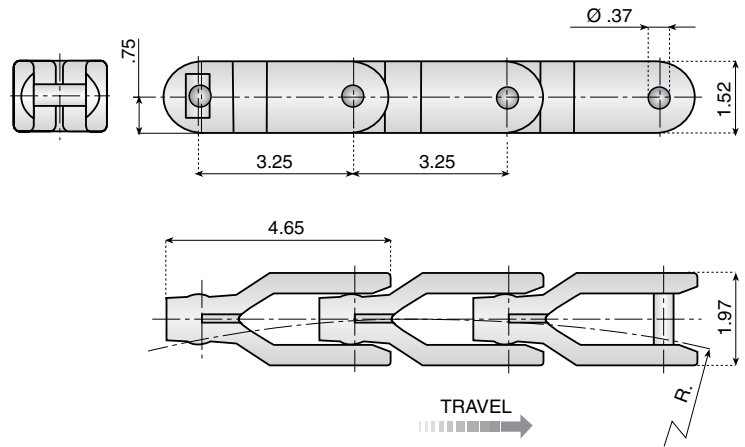
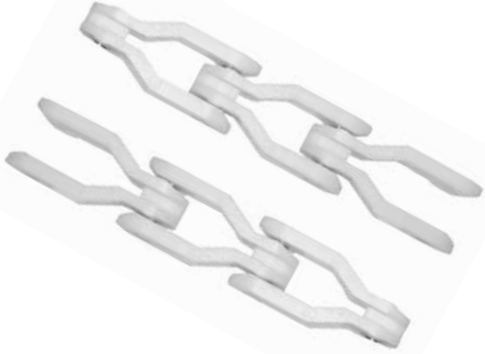

Material: White acetal with stainless steel pins.

Chain Reference	Part Number	Min. Radius	Breaking Load (lbs.)	Weight (lbs. per ft.)
CC-1400	11096	25.98	4050	2.17

See page 124 for compatible sprockets.

CC 1400 TAB

Case/Crate Conveyor Chains

Standard Length: 10ft. Pitches: 37

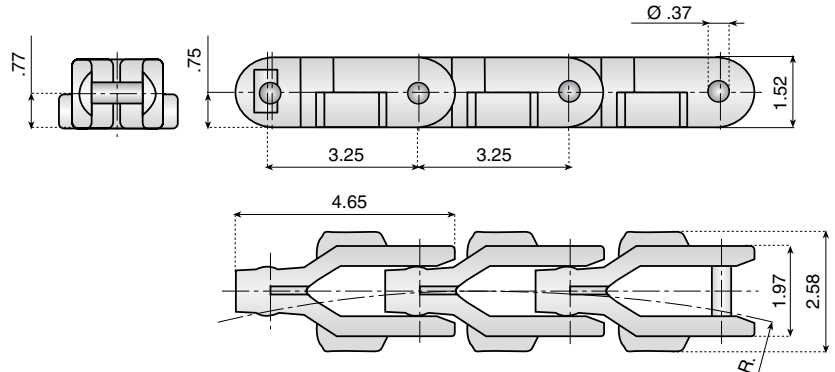

Material: White acetal with stainless steel pins.

Chain Reference	Part Number	Min. Radius	Breaking Load (lbs.)	Weight (lbs. per ft.)
CC 1400 TAB	11098	25.98	4050	2.31

See page 124 for compatible sprockets.

CC 1431 TAB

Case/Crate Conveyor Chains

CC 1431 TAB is similar to CC 1400 Tab, but with a taller link height.

Standard Length: 10ft. Pitches: 37

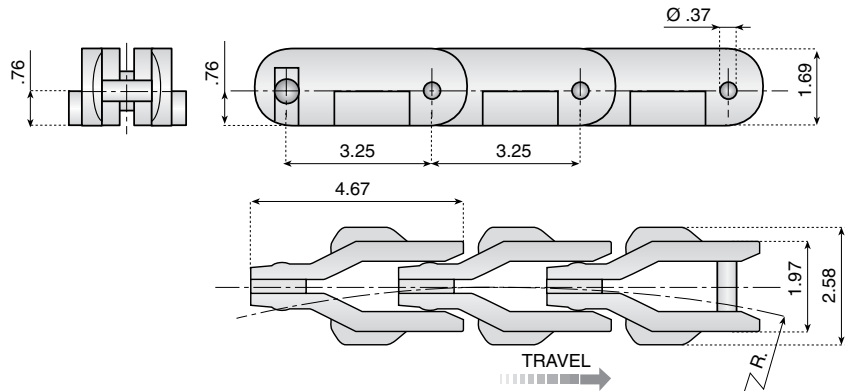

Material: White acetal with stainless steel pins.

Chain Reference	Part Number	Min. Radius	Breaking Load (lbs.)	Weight (lbs. per ft.)
CC 1431 TAB	11087	25.98	4050	2.31

See page 124 for compatible sprockets.

Straight Running Plastic Chains

LBP 821

Double Hinge Straight Running Chains with Low Noise Accumulation Rollers

- Heavy duty
- High load
- Low noise rollers
- Reduced back-line pressure

Ideal for the food and beverage industry packaging line and general purpose conveying applications to reduce pressure created between product and flite surface. The small width rollers provide a stable conveying surface and enable the product to be handled without damage, while continuing a positive forward motion.

Standard Length: 5ft.
Pitches: 40

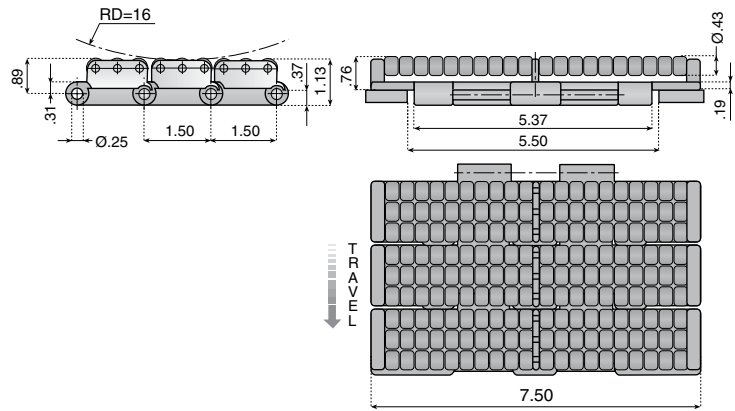

Material: "LFG Dark Grey" Low friction acetal chain.
Water blue acetal resin rollers with austenitic steel pins.

Chain Reference	Part Number	Breaking Load (lbs.)	L (width)	Weight (lbs./ft.)
LBP 821 K750	11055	1866	7-1/2	3.71

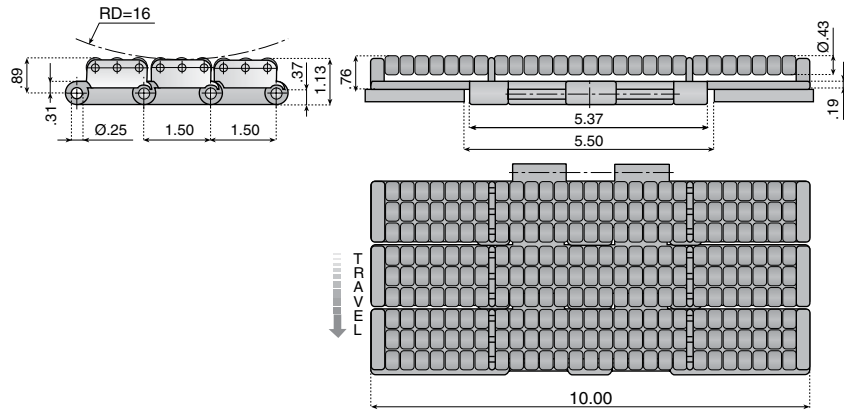

Material: "LFG Dark Grey" Low friction acetal chain.
Water blue acetal resin rollers with austenitic steel pins.

Chain Reference	Part Number	Breaking Load (lbs.)	L (width)	Weight (lbs./ft.)
LBP 821 K1000	11056	1866	10	4.64

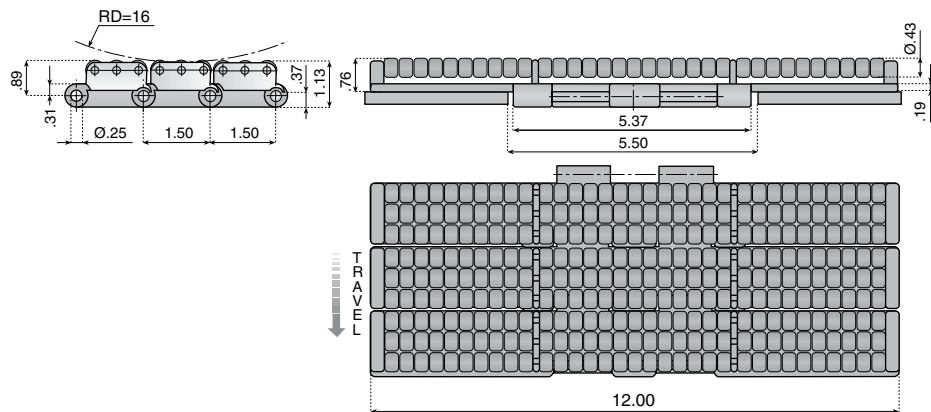

Material: "LFG Dark Grey" Low friction acetal chain.
Water blue acetal resin rollers with austenitic steel pins.

Chain Reference	Part Number	Breaking Load (lbs.)	L (width)	Weight (lbs./ft.)
LBP 821 K1200	11057	1866	12	5.37

Straight Running Plastic Chains

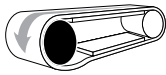

Drive Sprocket Options for LPB 821 Chains



Machined Split

Shaft Sized Bore Dia.	Teeth or Equivalent	Part Number
.71*	21	12901
1	21	12284S
1-1/4	21	12285S
1-7/16	21	12286S
1-1/2	21	12287S
.71*	23	12902
1	23	12288S
1-1/4	23	12289S
1-7/16	23	12290S
1-1/2	23	12291S
.71*	25	12903
1	25	12292S
1-1/4	25	12293S
1-7/16	25	12294S
1-1/2	25	12295S
.71*	27	121307
1	27	121308S
1-1/4	27	121309S
1-7/16	27	121310S
1-1/2	27	121311S

*Plain bore pilot hole. Not sized to a shaft.

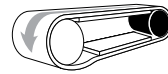

Idler Options for LPB 821 Chains



Machined

Part Number

-
121329S
121330S
121331S
121332S
-
121333S
121334S
121335S
121336S
-
121337S
121338S
121339S
121340S
-
121341S
121342S
121343S
121344S

See all sprockets and idlers on pages 101-125

Straight Running Plastic Chains

LBP 8257

Heavy Duty Single Hinge Straight Running Chains with Low Noise Accumulation Rollers

- High breaking load
- High load
- Low noise rollers
- Reduced back-line pressure
- Helps standardize conveyor construction
- Same hinge width available in many additional chain types.

Ideal for the food and beverage industry packaging line and general purpose conveying applications to reduce pressure created between product and flite surface. The small width rollers provide a stable conveying surface and enable the product to be handled without damage, while continuing a positive forward motion.

Standard Length: 5ft.
Pitches: 40

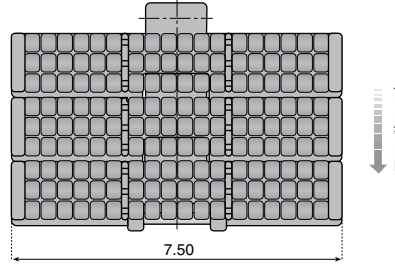
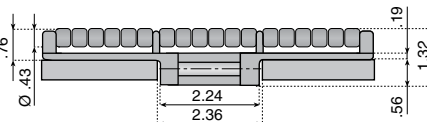
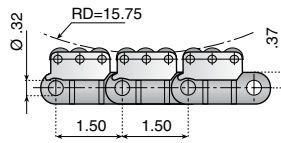

Material: "LFG Dark Grey" Low friction acetal chain.
Water blue acetal resin rollers with austenitic steel pins.

Chain Reference	Part Number	Breaking Load (lbs.)	L (width)	Weight (lbs./ft.)
LBP 8257 K750	11076	2250	7-1/2	3.80

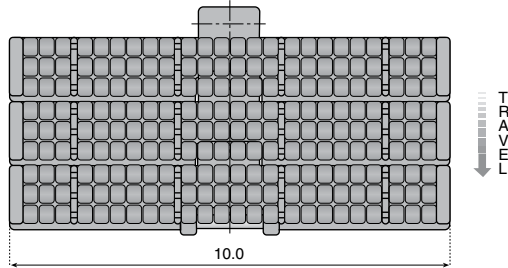
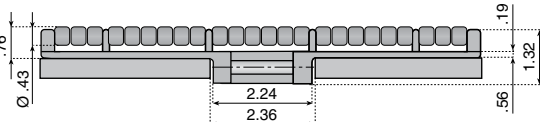
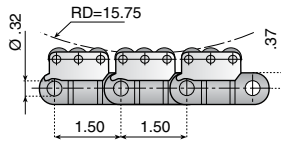

Material: "LFG Dark Grey" Low friction acetal chain.
Water blue acetal resin rollers with austenitic steel pins.

Chain Reference	Part Number	Breaking Load (lbs.)	L (width)	Weight (lbs./ft.)
LBP 8257 K1000	11077	2250	10	4.84

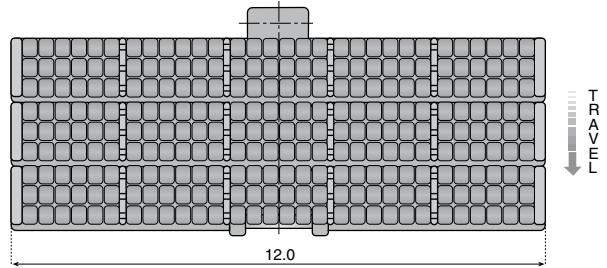
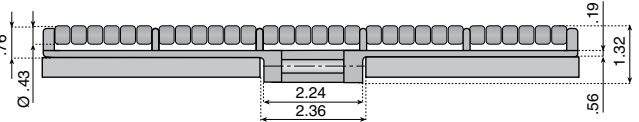
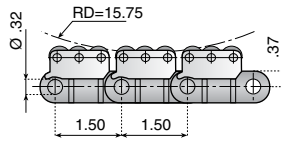

Material: "LFG Dark Grey" Low friction acetal chain.
Water blue acetal resin rollers with austenitic steel pins.

Chain Reference	Part Number	Breaking Load (lbs.)	L (width)	Weight (lbs./ft.)
LBP 8257 K1200	11078	2250	12	5.44

Straight Running Plastic Chains

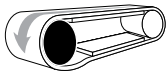

Drive Sprocket Options for LPB 8257 Chains



Machined Split



Molded Split

Shaft Sized Bore Dia.	Teeth or Equivalent	Part Number	Part Number
.71*	9	12914	-
1	9	12346S	-
1-1/4	9	12347S	-
1-7/16	9	12347SK	-
1-1/2	9	12348S	-
.71*	10	12915	-
1	10	12349S	321009
1-1/4	10	12350S	321010
1-7/16	10	12350SK	321011
1-1/2	10	12351S	321012
.71*	11	12916	-
1	11	12352S	-
1-1/4	11	12353S	-
1-7/16	11	12353SK	-
1-1/2	11	12354S	-
.71*	12	12917	-
1	12	12355S	32114
1-1/4	12	12356S	32115
1-7/16	12	12356SK	32116
1-1/2	12	12357S	32117

*Plain bore pilot hole. Not sized to a shaft.

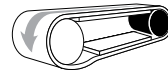

Idler Options for LPB 8257 Chains



Machined Split



Molded Split

Part Number	Part Number
-	-
121768S	-
121769S	-
121769SK	-
121770S	-
-	-
121771S	321013
121772S	321014
121772SK	321015
121773S	321016
-	-
121774S	-
121775S	-
121775SK	-
121776S	-
-	-
121777S	32119
121778S	32120
121778SK	32121
121779S	32122

See all sprockets and idlers on pages 101-125

LBP 831

Single Hinge Straight Running Chains with Low Noise Accumulation Rollers

- High load
- Low noise rollers
- Reduced back-line pressure

Ideal for the food and beverage industry packaging line and general purpose conveying applications to reduce pressure created between product and flite surface. The small width rollers provide a stable conveying surface and enables the product to be handled without damage, while continuing a positive forward motion.

Standard Length: 5ft.
Pitches: 40

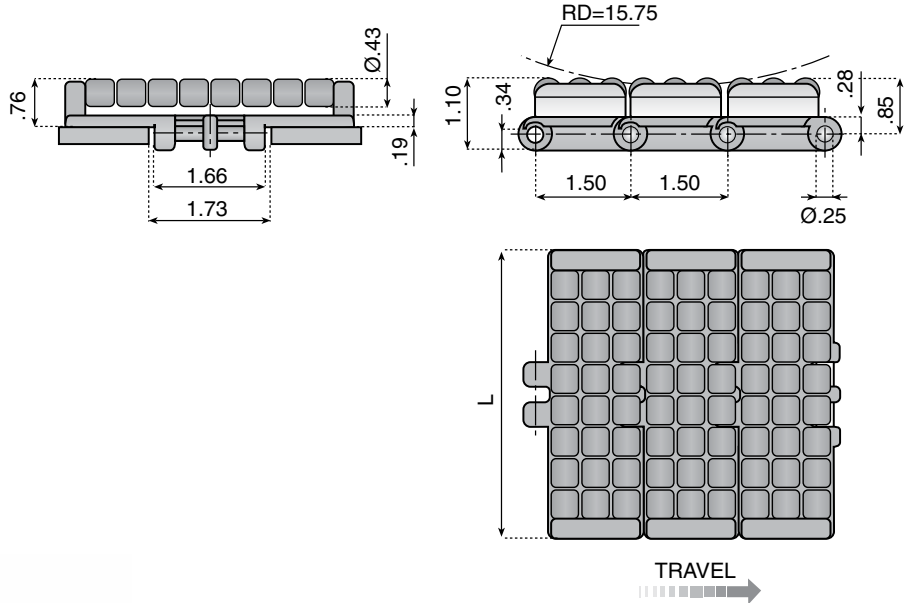

Material: "LFG Dark Grey" Low friction acetal chain.
 Water blue acetal resin rollers with austenitic steel pins.

Chain Reference	Part Number	Breaking Load (lbs.)	L (width)	Weight (lbs./ft.)
LBP 831 K325	11053	1124	3-1/4	1.45
LBP 831 K450	11054	1124	4-1/2	1.92

Straight Running Plastic Chains

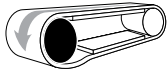

Drive Sprocket Options for LBP 831 Chains

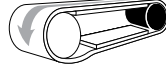

Idler Options for LBP 831 Chains



Shaft Sized Bore Dia.	Teeth or Equivalent	Drive Sprocket Options		Idler Options			
		Machined Split Part Number	Molded Split Part Number	Machined Split Part Number	Molded Split Part Number	Low-Friction Molded Part Number	Molded Split Part Number
.71*	19	12961	-	-	-	-	-
1	19	12924S	-	121147S	-	-	-
1-1/4	19	12925S	-	121148S	-	-	-
1-7/16	19	12926S	-	121149S	-	-	-
1-1/2	19	12927S	-	121150S	-	-	-
.71*	21	12962	-	-	-	-	-
1	21	12928S	32057	121151S	321095	32866	32077B
1-1/4	21	12929S	32058	121152S	321096	32867	32078B
1-7/16	21	12930S	32059	121153S	321097	32868	32079B
1-1/2	21	12931S	32060	121154S	321098	32869	32080B
.71*	23	12963	-	-	-	-	-
1	23	12932S	32104	121155S	321100	32874	-
1-1/4	23	12933S	32105	121156S	321101	32875	-
1-7/16	23	12934S	32106	121157S	321102	32876	-
1-1/2	23	12935S	32107	121158S	321103	32877	-
.71*	25	12964	-	-	-	-	-
1	25	12936S	32069	121159S	321105	32870	32081B
1-1/4	25	12937S	32070	121160S	321106	32871	32082B
1-7/16	25	12938S	32071	121161S	321107	32872	32083B
1-1/2	25	12939S	32072	121162S	321108	32873	32084B
.71*	27	121125	-	-	-	-	-
1	27	121126S	-	121163S	-	-	-
1-1/4	27	121127S	-	121164S	-	-	-
1-7/16	27	121128S	-	121165S	-	-	-
1-1/2	27	121129S	-	121166S	-	-	-

*Plain bore pilot hole. Not sized to a shaft.

See all sprockets and idlers on pages 101-125

Side Flexing Plastic Chains

LBP 882 TAB

Side Flexing Chains with Low Noise Accumulation Rollers

- High load
- Low friction rollers
- Low noise rollers

Ideal for the food and beverage industry packaging line and general purpose conveying applications to reduce pressure created between product and flite surface. The small width rollers provide a stable conveying surface and enable the product to be handled without damage, while continuing a positive forward motion.

Standard Length: 5ft.
Pitches: 40

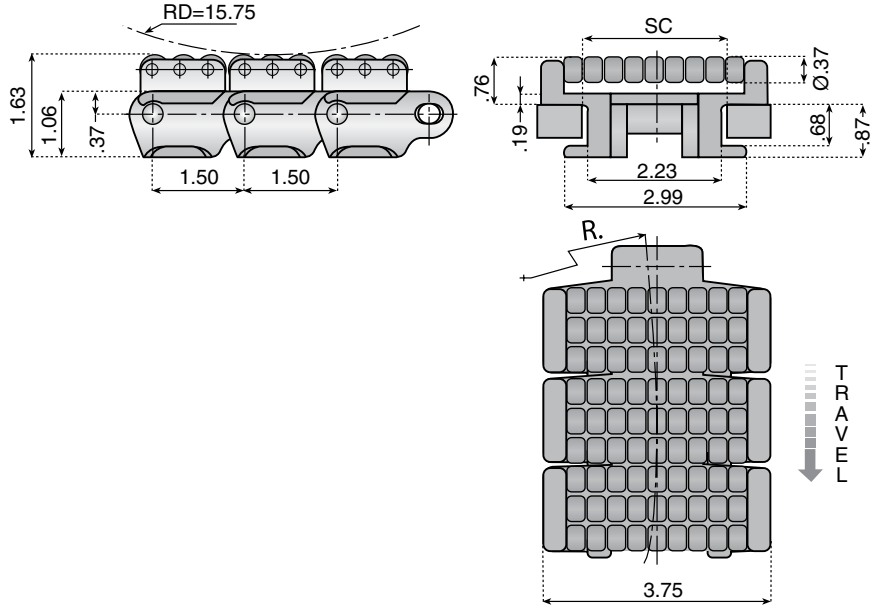

Material: "LFG Grey" Low friction acetal chain. Water blue acetal resin rollers with austenitic steel pins.

Chain Reference	Part Number	Breaking Load (lbs.)	L (width)	R Min.	SC Straight	SC Curved	Weight (lbs. per ft.)
LBP 882 TAB K375	11070	2248	3-3/4	24	2.36	2.28	2.22

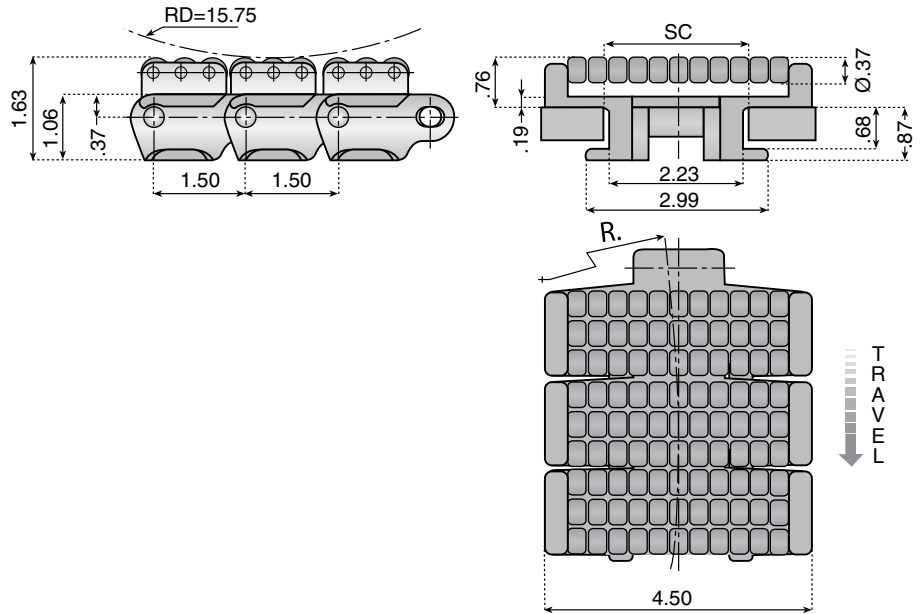

Material: "LFG Grey" Low friction acetal chain. Water blue acetal resin rollers with austenitic steel pins.

Chain Reference	Part Number	Breaking Load (lbs.)	L (width)	R Min.	SC Straight	SC Curved	Weight (lbs. per ft.)
LBP 882 TAB K450	11071	2248	4-1/2	24	2.36	2.28	2.71

Side Flexing Plastic Chains

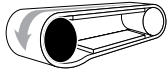

Drive Sprocket Options for LPB 882 TAB Chains



Machined Split



Molded Split

Shaft Sized Bore Dia.	Teeth or Equivalent	Part Number	Part Number
.71*	9	12914	-
1	9	12346S	-
1-1/4	9	12347S	-
1-7/16	9	12347SK	-
1-1/2	9	12348S	-
.71*	10	12915	-
1	10	12349S	321009
1-1/4	10	12350S	321010
1-7/16	10	12350SK	321011
1-1/2	10	12351S	321012
.71*	11	12916	-
1	11	12352S	-
1-1/4	11	12353S	-
1-7/16	11	12353SK	-
1-1/2	11	12354S	-
.71*	12	12917	-
1	12	12355S	32114
1-1/4	12	12356S	32115
1-7/16	12	12356SK	32116
1-1/2	12	12357S	32117

*Plain bore pilot hole. Not sized to a shaft.

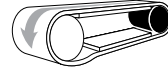

Idler Options for LPB 882 TAB Chains



Machined Split



Molded Split

Part Number	Part Number
-	-
121768S	-
121769S	-
121769SK	-
121770S	-
-	-
121771S	321013
121772S	321014
121772SK	321015
121773S	321016
-	-
121774S	-
121775S	-
121775SK	-
121776S	-
-	-
121777S	32119
121778S	32120
121778SK	32121
121779S	32122

See all sprockets and idlers on pages 101-125

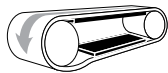

Track Options for LPB 882 TAB Chains

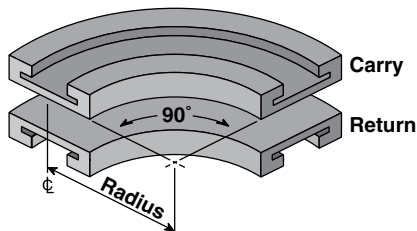

Corner Track

Part Number	Track Width	Radius (inches)
VT-982-T-24-0450	5.0	24

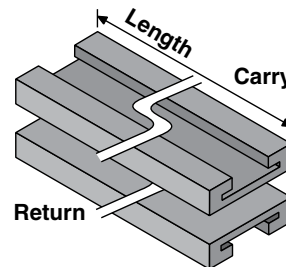

Straight Track

Part Number	Track Width	Length (feet)
VT-982-T-S-0450-3	5.0	3
VT-982-T-S-0450-6	5.0	6
VT-982-T-S-0450-10	5.0	10

See all ValuTrac modules on pages 130-145

Side Flexing Plastic Chains

LBP 882 TAB (cont.)

Side Flexing Chains with Low Noise Accumulation Rollers

- High load
- Low friction rollers
- Low noise rollers

Ideal for the food and beverage industry packaging lines and general purpose conveying applications to reduce pressure created between product and flite surface. The small width rollers provide a stable conveying surface and enable the product to be handled without damage, while continuing a positive forward motion.

Standard Length: 5ft.
Pitches: 40

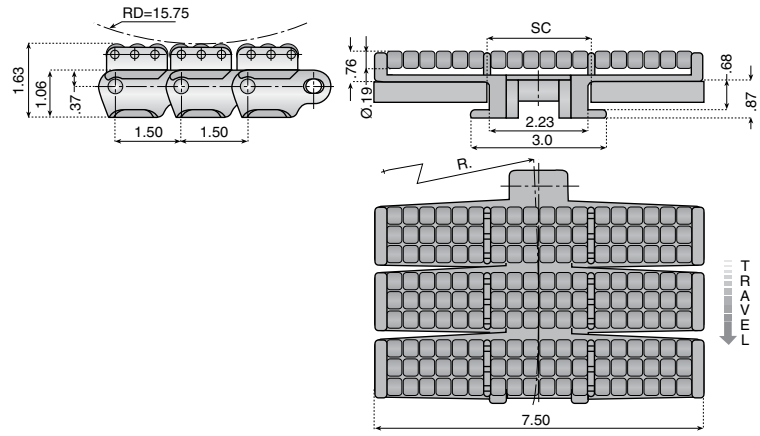

Material: "LFG Grey" Low friction acetal chain. Water blue acetal resin rollers with austenitic steel pins.

Chain Reference	Part Number	Breaking Load (lbs.)	L (width)	R Min.	SC Straight	SC Curved	Weight (lbs. per ft.)
LBP 882 TAB K750	11072	2248	7-1/2	24	2.40	2.36	3.16

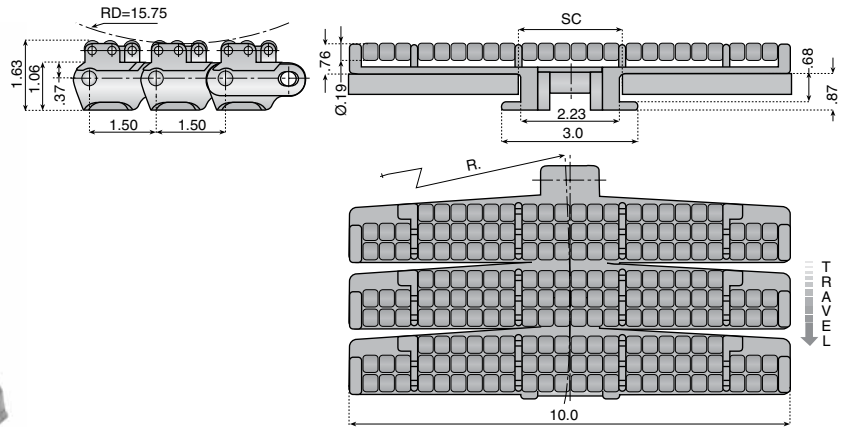

Material: "LFG Grey" Low friction acetal chain. Water blue acetal resin rollers with austenitic steel pins.

Chain Reference	Part Number	Breaking Load (lbs.)	L (width)	R Min.	SC Straight	SC Curved	Weight (lbs. per ft.)
LBP 882 TAB K1000	11069	2248	10	24	2.40	2.36	3.97

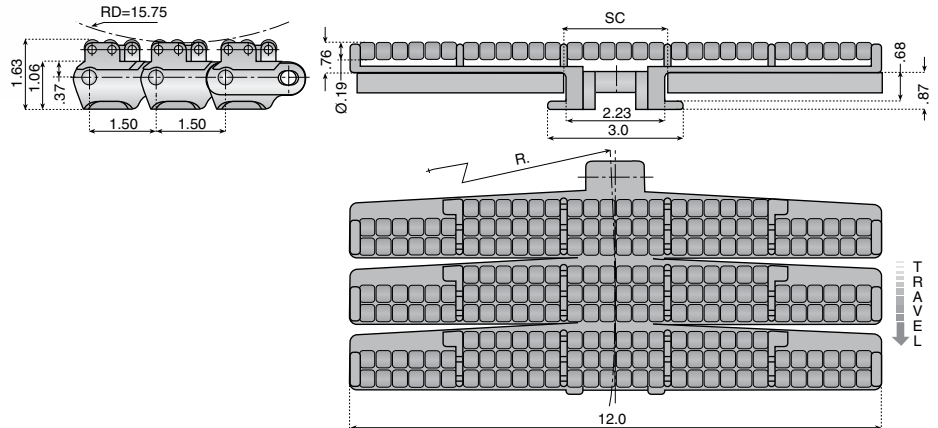

Material: "LFG Grey" Low friction acetal chain. Water blue acetal resin rollers with austenitic steel pins.

Chain Reference	Part Number	Breaking Load (lbs.)	L (width)	R Min.	SC Straight	SC Curved	Weight (lbs. per ft.)
LBP 882 TAB K1200	11068	2248	12	24	2.40	2.36	4.37

Side Flexing Plastic Chains

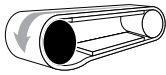

Drive Sprocket Options for LPB 882 TAB Chains



Machined Split

Molded Split

Shaft Sized Bore Dia.	Teeth or Equivalent	Part Number	Part Number
.71*	9	12914	-
1	9	12346S	-
1-1/4	9	12347S	-
1-7/16	9	12347SK	-
1-1/2	9	12348S	-
.71*	10	12915	-
1	10	12349S	321009
1-1/4	10	12350S	321010
1-7/16	10	12350SK	321011
1-1/2	10	12351S	321012
.71*	11	12916	-
1	11	12352S	-
1-1/4	11	12353S	-
1-7/16	11	12353SK	-
1-1/2	11	12354S	-
.71*	12	12917	-
1	12	12355S	32114
1-1/4	12	12356S	32115
1-7/16	12	12356SK	32116
1-1/2	12	12357S	32117

*Plain bore pilot hole. Not sized to a shaft.

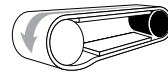

Idler Options for LPB 882 TAB Chains



Machined Split

Molded Split

Part Number	Part Number
-	-
121768S	-
121769S	-
121769SK	-
121770S	-
-	-
121771S	321013
121772S	321014
121772SK	321015
121773S	321016
-	-
121774S	-
121775S	-
121775SK	-
121776S	-
-	-
121777S	32119
121778S	32120
121778SK	32121
121779S	32122

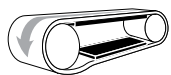

Track Options for LPB 882 TAB Chains

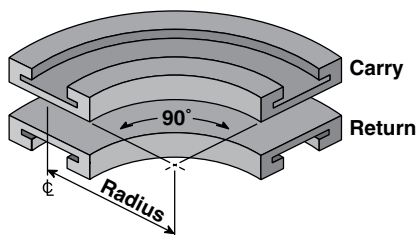

Corner Track

Part Number	Track Width	Radius (inches)
VT-982-T-24-0750	8.0	24
VT-982-T-24-1000	10.5	24
VT-982-T-24-1200	12.5	24

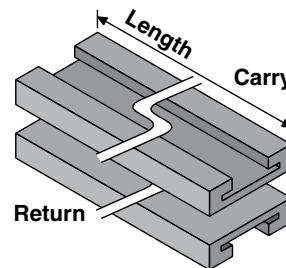

See all sprockets and idlers on pages 101-125

Straight Track

Part Number	Track Width	Length (feet)
VT-982-T-S-0750-3	8.0	3
VT-982-T-S-0750-6	8.0	6
VT-982-T-S-0750-10	8.0	10
VT-982-T-S-1000-3	10.5	3
VT-982-T-S-1000-6	10.5	6
VT-982-T-S-1000-10	10.5	10
VT-982-T-S-1200-6	12.5	6
VT-982-T-S-1200-10	12.5	10

See all ValuTrac modules on pages 130-145

Side Flexing Plastic Chains

LBP 882 M

Magnetic Side Flexing Chains with Low Noise Accumulation Rollers

- High load
- Low friction, low noise rollers
- Pin roller support added to maintain a flat and consistent carrying surface
- Easy maintenance

Series LBP 882 M is securely retained in the curve by magnets embedded in the chain track material. There are no tabs or bevels on these chains, so they can be easily removed for maintenance or cleaning, without dismantling the chain.

Ideal for the food and beverage industry packaging lines and general purpose conveying applications to reduce pressure created between product and flite surface. The small width rollers provide a stable conveying surface and enable the product to be handled without damage, while continuing a positive forward motion.

Standard Length: 10ft.
Pitches: 40

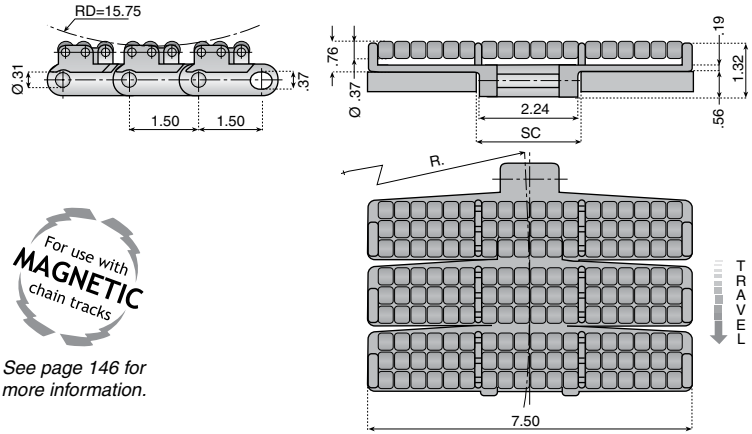

See page 146 for more information.

Material: "LFG Grey" Low friction acetal chain. Water blue acetal resin rollers with austenitic steel pins.

Chain Reference	Part Number	Breaking Load (lbs.)	L (width)	R Min.	SC Straight	SC Curved	Weight (lbs. per ft.)
LBP 882 M K750	11073	2248	7-1/2	24	2.40	2.36	2.62

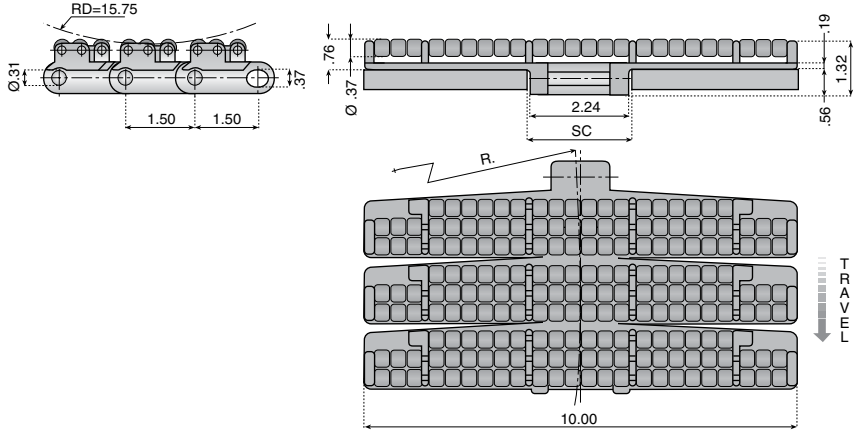

Material: "LFG Grey" Low friction acetal chain. Water blue acetal resin rollers with austenitic steel pins.

Chain Reference	Part Number	Breaking Load (lbs.)	L (width)	R Min.	SC Straight	SC Curved	Weight (lbs. per ft.)
LBP 882 M K1000	11074	2248	10	24	2.40	2.36	3.33

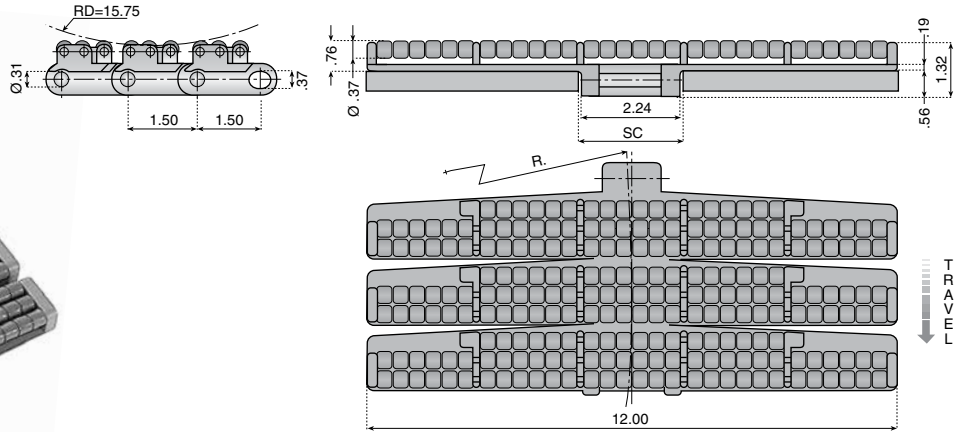

Material: "LFG Grey" Low friction acetal chain. Water blue acetal resin rollers with austenitic steel pins.

Chain Reference	Part Number	Breaking Load (lbs.)	L (width)	R Min.	SC Straight	SC Curved	Weight (lbs. per ft.)
LBP 882 M K1200	11075	2248	12	24	2.40	2.36	3.93

Side Flexing Plastic Chains

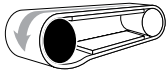

Drive Sprocket Options for LPB 882 M Chains



Machined Split



Molded Split

Shaft Sized Bore Dia.	Teeth or Equivalent	Part Number	Part Number
.71*	9	12914	-
1	9	12346S	-
1-1/4	9	12347S	-
1-7/16	9	12347SK	-
1-1/2	9	12348S	-
.71*	10	12915	-
1	10	12349S	321009
1-1/4	10	12350S	321010
1-7/16	10	12350SK	321011
1-1/2	10	12351S	321012
.71*	11	12916	-
1	11	12352S	-
1-1/4	11	12353S	-
1-7/16	11	12353SK	-
1-1/2	11	12354S	-
.71*	12	12917	-
1	12	12355S	32114
1-1/4	12	12356S	32115
1-7/16	12	12356SK	32116
1-1/2	12	12357S	32117

*Plain bore pilot hole. Not sized to a shaft.

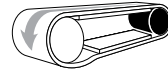

Idler Options for LPB 882 M Chains



Machined Split



Molded Split

Part Number	Part Number
-	-
121768S	-
121769S	-
121769SK	-
121770S	-
-	-
121771S	321013
121772S	321014
121772SK	321015
121773S	321016
-	-
121774S	-
121775S	-
121775SK	-
121776S	-
-	-
121777S	32119
121778S	32120
121778SK	32121
121779S	32122

See all sprockets and idlers on pages 101-125

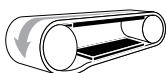

Track Options for LPB 882 M Chains

Magnetic corner tracks for these chains are available. Please see the complete System Plast Conveyor Chains catalog for details or contact our Engineering Department.

Side Flexing Plastic Chains

LBP 878 TAB

Side Flexing Chains with Low Noise Accumulation Rollers

- Small sideflexing radius of 7-7/8 inches
- Low friction rollers
- Low noise rollers
- Preferred with turn discs

Ideal for the food and beverage industry packaging line (PET bottle packs in heat shrink film) and general purpose conveying applications to reduce pressure created between product and flite surface. The small width rollers provide a stable conveying surface and enable the product to be handled without damage, while continuing a positive forward motion.

Standard Length: 5ft.
Pitches: 40

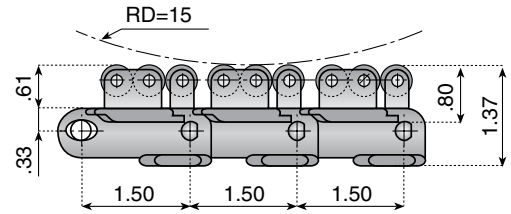
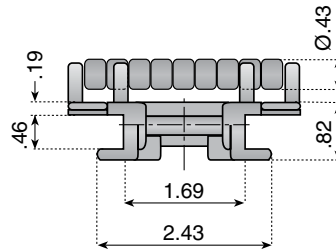

**7 7/8 inch
side flexing radius!**

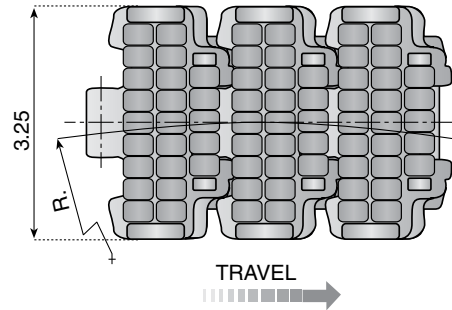

Material: "LFG Grey" Low friction acetal chain. Water blue acetal resin rollers.

Chain Reference	Part Number	Breaking Load (lbs.)	L (width)	R Min.	SC Straight	SC Curved	Weight (lbs. per ft.)
LBP 878 TAB K325	11388	1349	3-1/4	7.87	1.81	1.77	2.15

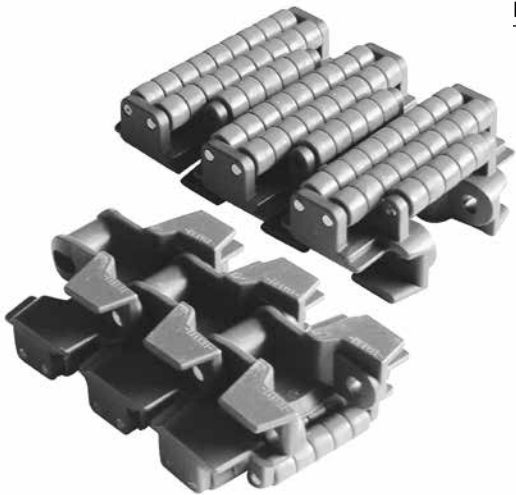

Side Flexing Plastic Chains

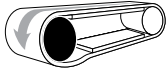

Drive Sprocket Options for LPB 878 TAB Chains



Machined Split



Molded Split

Shaft Sized Bore Dia.	Teeth or Equivalent	Part Number	Part Number
.71*	9	12910	-
1	9	12382S	-
1-1/4	9	12383S	-
1-7/16	9	12384S	-
1-1/2	9	12385S	-
.71*	10	12911	-
1	10	12386S	321001
1-1/4	10	12387S	321002
1-7/16	10	12388S	321003
1-1/2	10	12389S	321004
.71*	11	12912	-
1	11	12390S	-
1-1/4	11	12391S	-
1-7/16	11	12392S	-
1-1/2	11	12393S	-
.71*	12	12913	-
1	12	12394S	32400
1-1/4	12	12395S	32711
1-7/16	12	12396S	32401
1-1/2	12	12397S	32402

*Plain bore pilot hole. Not sized to a shaft.

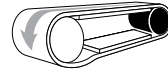

Idler Options for LPB 878 TAB Chains



Machined Split



Molded Split

Part Number	Part Number
-	-
121752S	-
121753S	-
121754S	-
121755S	-
-	-
121756S	321005
121757S	321006
121758S	321007
121759S	321008
-	-
121760S	-
121761S	-
121762S	-
121763S	-
-	-
121764S	32403
121765S	32404
121766S	32405
121767S	32406

See all sprockets and idlers on pages 101-125

Improved Turning Disk Designs!

These chains can also use horizontal disks, ideal for numerous curves or alpine applications. See page 126 for complete details.

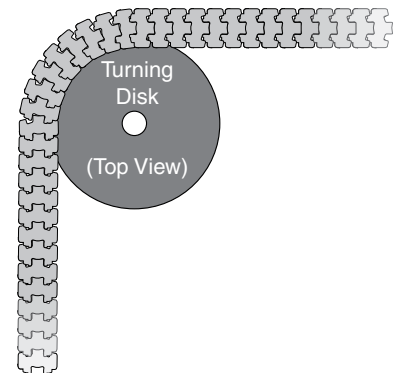

FT series Flat Top belts

Benefits and Features

- Easy installation and maintenance
- High mechanical strength and wear resistance
- Excellent product handling
- High performance

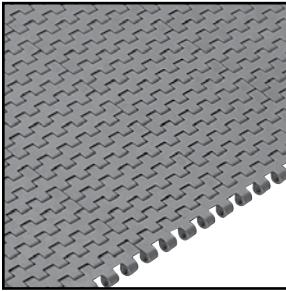

Material name: **LFG** Low Friction Acetal Resin

It is identical to the delrin acetal material and offers an improved coefficient of friction. This material is suitable for use in high speed applications.

Operating temperatures:

dry: - 40°F to + 176°F

wet: 32°F to +149°F

Color: Dark Grey

This material is FDA (Food and Drug Administration) approved for direct contact with food.

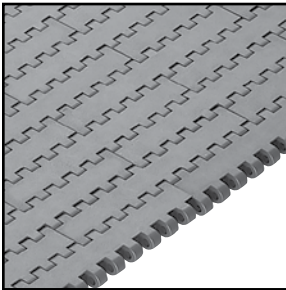

Material name: **XPG** Extra Performance

Extra performance acetal with a very low coefficient of friction compared to other LF materials. Suitable for high speed applications and reduced lubrication. Equivalent to other manufacturer's high performance materials.

Operating temperatures:

dry: - 40°F to + 176°F

wet: 32°F to +149°F

Color: Dark Brown

This material is FDA (Food and Drug Administration) approved for direct contact with food.

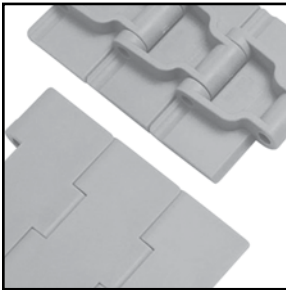

Material name: **NG** New Generation

Extra performance PBT with the lowest coefficient of friction in our range, resulting in medium strength and optimum wear resistance, along with reduced plate wear and reduced pitch elongation. Suitable for dry running applications. NG material should not be exposed to high humidity levels or wet conditions at temperatures above 140°F. Available in flat top chain exclusively from System Plast .

Operating temperatures:

up to 248°F

Color: Light Grey

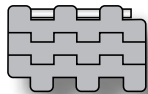

Belt widths from 3 inches to 10 feet!

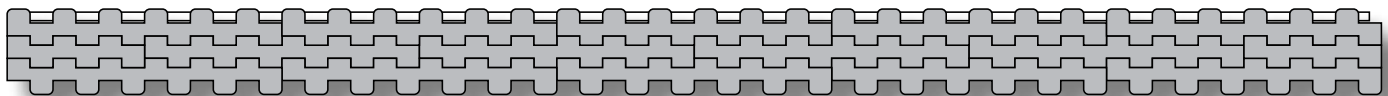

Nose Bars

for 2121 Series Belts

The design of 2121 series belts and these nose bars allow the creation of extremely short transfers.

For delivery information, contact customer service.

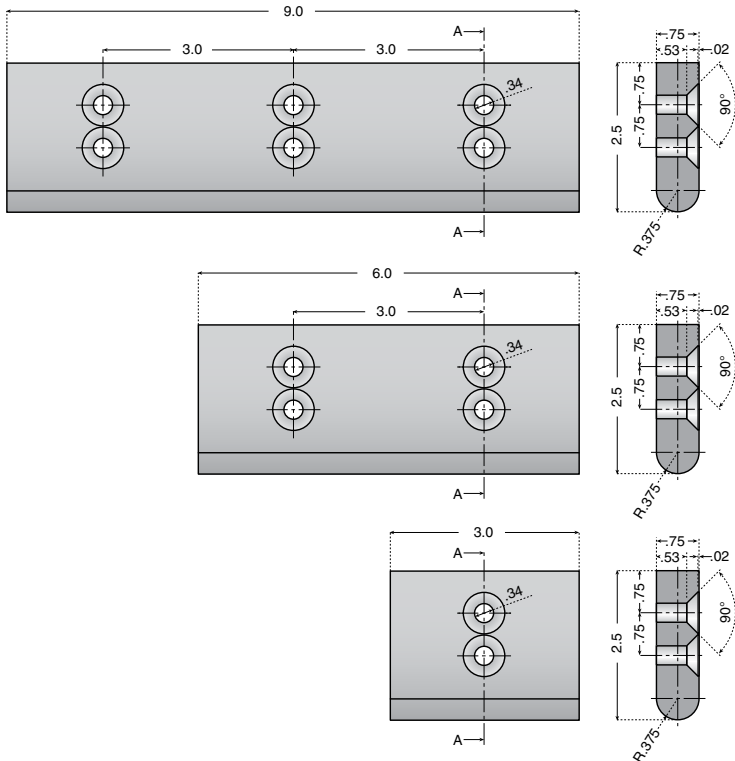

Material: Nolu-SR

Part Number	Width	Height	Radius
14143A	3.0	.75	.375
14144A	6.0	.75	.375
14145A	9.0	.75	.375

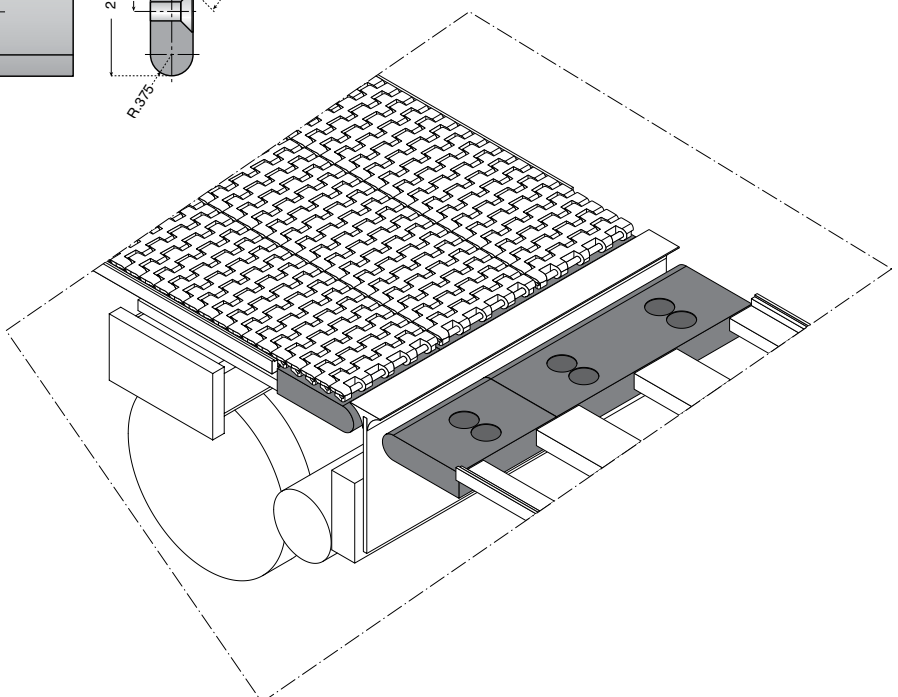
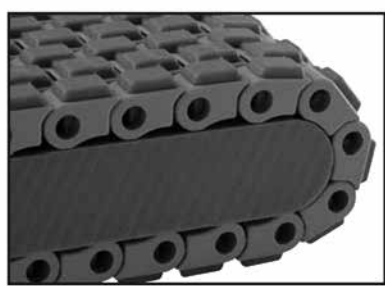
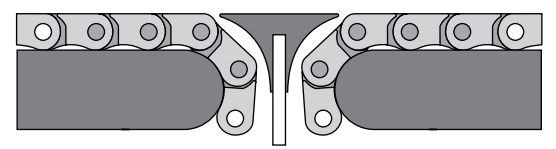

Flat Top Belts

2121

Straight Running Belts with Single Piece Widths

- 1/2 inch pitch
- .34 (11/32) inch height
- Easy installation and maintenance
- High mechanical strength and wear resistance
- No gaps between parallel chains
- Excellent product handling

System Plast Flat Top Belts have a solid surface that makes them suitable for glass bottles and PET bottles, especially those with low contact area bases.

Standard Length: 10ft.
Pitches: 240

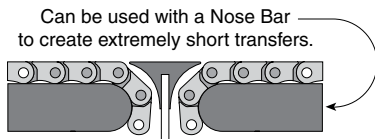

See page 75

For delivery information, contact customer service.

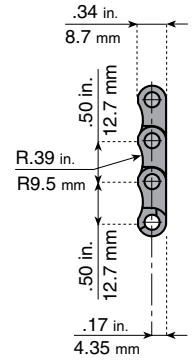
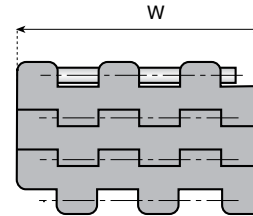
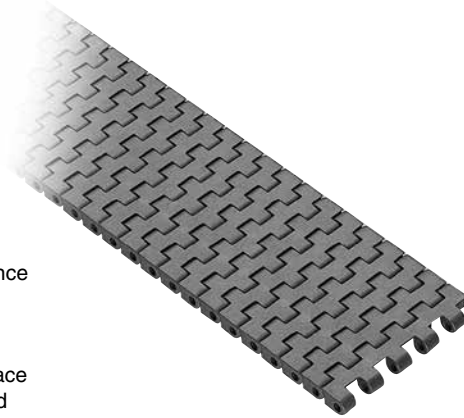

Material: "LFG Dark Grey" Low friction acetal chain. White PBT pins.

Chain Reference	Part Number	W (width)	Pitch	Backflex Radius	Max Load* (lbs. per ft.)	Weight (lbs. per sq. ft.)
LFG2121FT-K300	26050	3	.50	.40	1370	1.36
LFG2121FT-K325	26051	3-1/4	.50	.40	1370	1.36
LFG2121FT-K450	26052	4-1/2	.50	.40	1370	1.36
LFG2121FT-K600	26053	6	.50	.40	1370	1.36
LFG2121FT-K750	26054	7-1/2	.50	.40	1370	1.36

*Max. load changes according to belt width. Example: max. load for a 6 inch wide belt is half of the lbs. per foot figure shown.

Straight Running Belts with Single Piece Widths and Two Positioners

- 1/2 inch pitch
- .34 (11/32) inch height
- Easy installation and maintenance
- High mechanical strength and wear resistance
- No gaps between parallel chains
- Excellent product handling

System Plast Flat Top Belts have a solid surface that makes them suitable for glass bottles and PET bottles, especially those with low contact area bases.

Standard Length: 10ft.
Pitches: 240

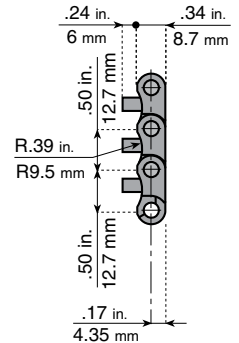
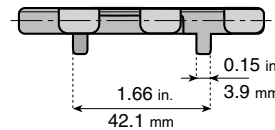
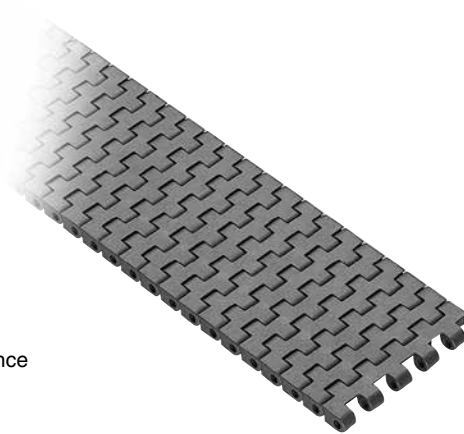

Material: "LFG Dark Grey" Low friction acetal chain. White PBT pins.

Chain Reference	Part Number	W (width)	Pitch	Backflex Radius	Max Load* (lbs. per ft.)	Weight (lbs. per sq. ft.)
LFG2121FT-PT-K300	26055	3	.50	.40	1370	1.36
LFG2121FT-PT-K325	26056	3-1/4	.50	.40	1370	1.36
LFG2121FT-PT-K450	26057	4-1/2	.50	.40	1370	1.36
LFG2121FT-PT-K600	26058	6	.50	.40	1370	1.36
LFG2121FT-PT-K750	26059	7-1/2	.50	.40	1370	1.36

*Max. load changes according to belt width. Example: max. load for a 6 inch wide belt is half of the lbs. per foot figure shown.

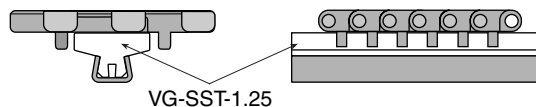

Flat Top Belts

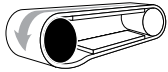

Drive Sprocket Options for 2121 Flat Top Belts

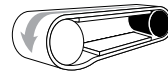

Idler Options for 2121 Flat Top Belts

Shaft Sized Bore Dia.	Teeth or Equivalent	Machined		Machined Split	
		Part Number	Part Number	Part Number	Part Number
.71*	16	125500GV	-	125500GV	-
1	16	125500VS	-	125500RIVS	-
1-1/4	16	125501VS	-	125501RIVS	-
.71*	20	125502GV	-	125502GV	-
1	20	125502VS	-	125502RIVS	-
1-1/4	20	125503VS	-	125503RIVS	-
1-7/16	20	125504VS	-	125504RIVS	-
1-1/2	20	125505VS	-	125505RIVS	-
.71*	24	125506GV	-	125506GV	-
1	24	125506VS	-	125506RIVS	-
1-1/4	24	125507VS	-	125507RIVS	-
1-7/16	24	125508VS	-	125508RIVS	-
1-1/2	24	125509VS	-	125509RIVS	-
.71*	28	125510GV	125600GV	125510GV	125600GV
1	28	125510VS	125600VS	125510RIVS	125600RVS
1-1/4	28	125511VS	125601VS	125511RIVS	125601RVS
1-7/16	28	125512VS	125602VS	125512RIVS	125602RVS
1-1/2	28	125513VS	125603VS	125513RIVS	125603RVS

*Plain bore pilot hole. Not sized to a shaft.



Molded Single Key



Molded Double Key



Molded Square Shaft



Molded Split

Shaft Sized Bore Dia.	Teeth or Equivalent	Part Number	Part Number	Part Number	Part Number
1-1/4	24	123190VS	123193VS	-	123197VS
1-7/16	24	123191VS	123194VS	-	123198VS
1-1/2	24	123192VS	123195VS	-	123199VS
1-1/2 x 1-1/2 sq.	28	-	-	123009VS	-
1-1/4	28	123000VS	123004VS	-	123010VS
1-7/16	28	123001VS	123005VS	-	123011VS
1-1/2	28	123002VS	123006VS	-	123012VS
1-3/4	28	123003VS	123007VS	-	123013VS

For delivery information, contact customer service.

See all sprockets and idlers on pages 101-125

Flat Top Belts

2121 FT

Straight Running Belts with Combined Piece Widths

- 1/2 inch pitch
- .34 (11/32) inch height
- Easy installation and maintenance
- High mechanical strength and wear resistance
- No gaps between parallel chains
- Excellent product handling

System Plast Flat Top Belts have a solid surface that makes them suitable for glass bottles and PET bottles, especially those with low contact area bases.

Standard Length: 10ft.
Pitches: 240

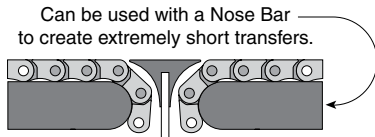

Can be used with a Nose Bar to create extremely short transfers.

See page 75

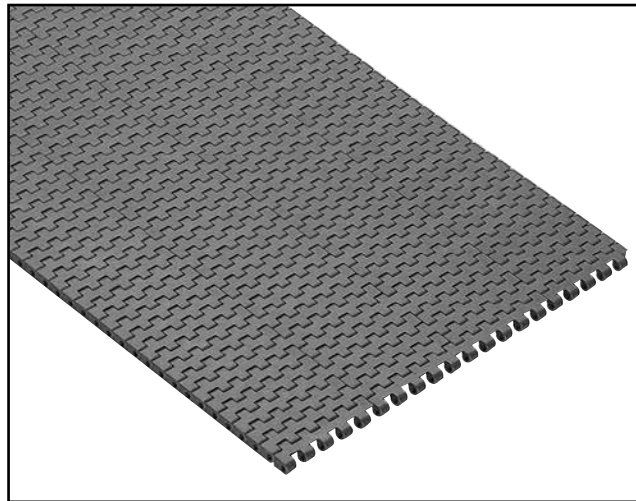
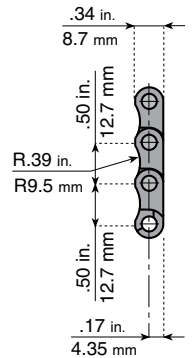
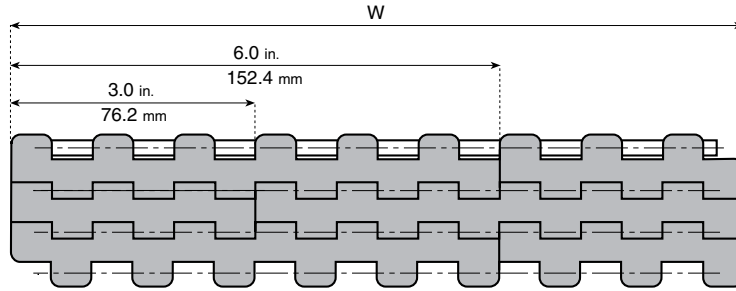

For delivery information, contact customer service.

Material: "LFG Dark Grey" Low friction acetal chain. White PBT pins. For "XP Dark Brown" material, add "XPG" to the end of the part number, example: **261102XPG**.

Chain Reference	Part Number	Width (in.)	Backflex Radius	Max Load* (lbs. per ft.)	Weight (lbs. per sq. ft.)
LFG2121FT-K900	261102	9	.40	1370	1.36
LFG2121FT-K1200	261103	12	.40	1370	1.36
LFG2121FT-K1500	261104	15	.40	1370	1.36
LFG2121FT-K1800	261105	18	.40	1370	1.36
LFG2121FT-K2100	261106	21	.40	1370	1.36
LFG2121FT-K2400	261107	24	.40	1370	1.36
LFG2121FT-K2700	261108	27	.40	1370	1.36
LFG2121FT-K3000	261109	30	.40	1370	1.36
LFG2121FT-K3300	261110	33	.40	1370	1.36
LFG2121FT-K3600	261111	36	.40	1370	1.36
LFG2121FT-K3900	261112	39	.40	1370	1.36
LFG2121FT-K4200	261113	42	.40	1370	1.36
LFG2121FT-K4500	261114	45	.40	1370	1.36
LFG2121FT-K4800	261115	48	.40	1370	1.36
LFG2121FT-K5100	261116	51	.40	1370	1.36
LFG2121FT-K5400	261117	54	.40	1370	1.36
LFG2121FT-K5700	261118	57	.40	1370	1.36
LFG2121FT-K6000	261119	60	.40	1370	1.36

*Max. load changes according to belt width. Example: max. load for a 24 inch wide belt is 2 times the lbs. per foot figure shown.

Flat Top Belts

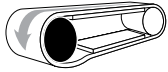

Drive Sprocket Options for 2121 FT Flat Top Belts

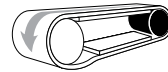

Idler Options for 2121 FT Flat Top Belts

Shaft Sized Bore Dia.	Teeth or Equivalent	Machined		Machined Split		Machined		Machined Split	
		Part Number	Part Number	Part Number	Part Number	Part Number	Part Number	Part Number	Part Number
.71*	16	125500GV	-	-	-	125500GV	-	-	-
1	16	125500VS	-	-	-	125500RIVS	-	-	-
1-1/4	16	125501VS	-	-	-	125501RIVS	-	-	-
.71*	20	125502GV	-	-	-	125502GV	-	-	-
1	20	125502VS	-	-	-	125502RIVS	-	-	-
1-1/4	20	125503VS	-	-	-	125503RIVS	-	-	-
1-7/16	20	125504VS	-	-	-	125504RIVS	-	-	-
1-1/2	20	125505VS	-	-	-	125505RIVS	-	-	-
.71*	24	125506GV	-	-	-	125506GV	-	-	-
1	24	125506VS	-	-	-	125506RIVS	-	-	-
1-1/4	24	125507VS	-	-	-	125507RIVS	-	-	-
1-7/16	24	125508VS	-	-	-	125508RIVS	-	-	-
1-1/2	24	125509VS	-	-	-	125509RIVS	-	-	-
.71*	28	125510GV	125600GV	-	-	125510GV	125600GV	-	-
1	28	125510VS	125600VS	-	-	125510RIVS	125600RVS	-	-
1-1/4	28	125511VS	125601VS	-	-	125511RIVS	125601RVS	-	-
1-7/16	28	125512VS	125602VS	-	-	125512RIVS	125602RVS	-	-
1-1/2	28	125513VS	125603VS	-	-	125513RIVS	125603RVS	-	-

*Plain bore pilot hole. Not sized to a shaft.



Molded Single Key



Molded Double Key



Molded Square Shaft



Molded Split

Shaft Sized Bore Dia.	Teeth or Equivalent	Part Number	Part Number	Part Number	Part Number
1-1/4	24	123190VS	123193VS	-	123197VS
1-7/16	24	123191VS	123194VS	-	123198VS
1-1/2	24	123192VS	123195VS	-	123199VS
1-1/2 x 1-1/2 sq.	28	-	-	123009VS	-
1-1/4	28	123000VS	123004VS	-	123010VS
1-7/16	28	123001VS	123005VS	-	123011VS
1-1/2	28	123002VS	123006VS	-	123012VS
1-3/4	28	123003VS	123007VS	-	123013VS

For delivery information, contact customer service.

See all sprockets and idlers on pages 101-125

SYSTEM PLAST™

Flat Top Belts with Rollers

LBP 2120

Flat Top Belts with Accumulation Rollers

- Easy installation and maintenance
- Optimum product stability
- High performance
- Easy to clean
- Long wear life
- Low noise rollers

Standard Length: 5ft.
Pitches: 120

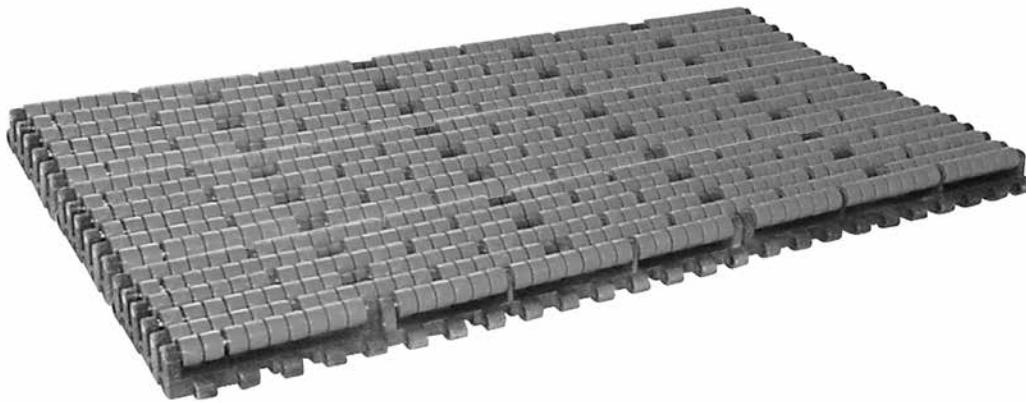
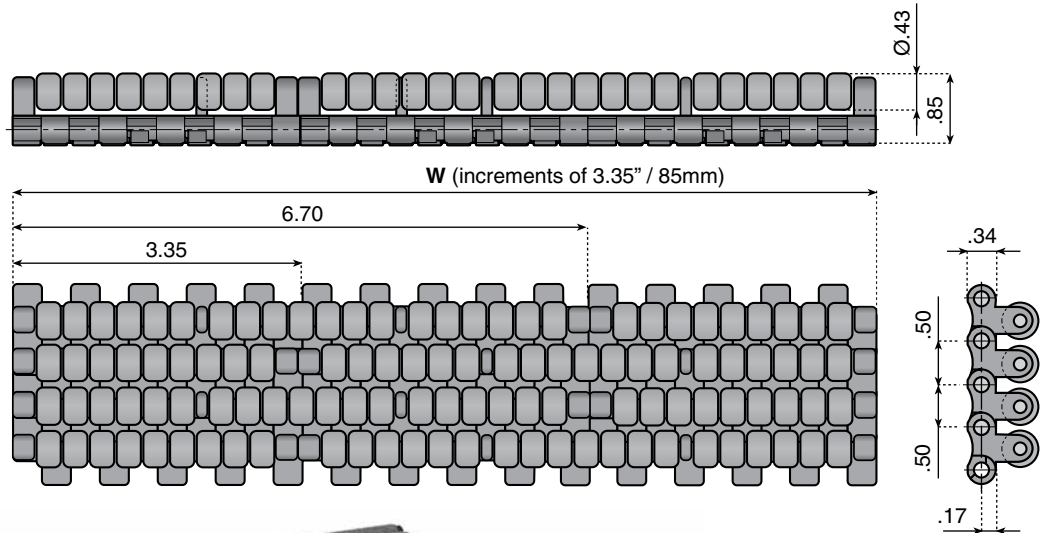

For delivery information, contact customer service.

Material: "LF Dark Grey" Low friction acetal belt. Water blue acetal resin rollers with stainless steel roller shaft.

Chain Reference	Width (mm)	Part Number	Backflex Radius	Max Load* (lbs. per ft.)	Weight (lbs. per sq. ft.)
LFG2120LBP-M0085		256500	9.85	1370	5.125
LFG2120LBP-M0170		256501	9.85	1370	5.125
LFG2120LBP-M0255		256502	9.85	1370	5.125
LFG2120LBP-M0340		256503	9.85	1370	5.125
LFG2120LBP-M0425		256504	9.85	1370	5.125
LFG2120LBP-M0510		256505	9.85	1370	5.125
LFG2120LBP-M0595		256506	9.85	1370	5.125
LFG2120LBP-M0680		256507	9.85	1370	5.125
LFG2120LBP-M0765		256508	9.85	1370	5.125
LFG2120LBP-M0850		256509	9.85	1370	5.125
LFG2120LBP-M0935		256510	9.85	1370	5.125
LFG2120LBP-M1020		256511	9.85	1370	5.125
LFG2120LBP-M1105		256512	9.85	1370	5.125
LFG2120LBP-M1190		256513	9.85	1370	5.125
LFG2120LBP-M1275		256514	9.85	1370	5.125
LFG2120LBP-M1360		256515	9.85	1370	5.125
LFG2120LBP-M1445		256516	9.85	1370	5.125
LFG2120LBP-M1530		256517	9.85	1370	5.125

*Max. load changes according to belt width. Example: max. load for a 24 inch wide belt is 2 times the lbs. per foot figure shown.

Flat Top Belts with Rollers

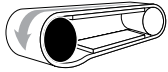

Drive Sprocket Options for LBP 2120 Flat Top Belts

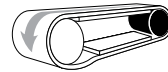

Idler Options for LBP 2120 Flat Top Belts

Shaft Sized Bore Dia.	Teeth or Equivalent	Machined		Machined Split	
		Part Number	Part Number	Part Number	Part Number
.71*	16	125500GV	-	125500GV	-
1	16	125500VS	-	125500RIVS	-
1-1/4	16	125501VS	-	125501RIVS	-
.71*	20	125502GV	-	125502GV	-
1	20	125502VS	-	125502RIVS	-
1-1/4	20	125503VS	-	125503RIVS	-
1-7/16	20	125504VS	-	125504RIVS	-
1-1/2	20	125505VS	-	125505RIVS	-
.71*	24	125506GV	-	125506GV	-
1	24	125506VS	-	125506RIVS	-
1-1/4	24	125507VS	-	125507RIVS	-
1-7/16	24	125508VS	-	125508RIVS	-
1-1/2	24	125509VS	-	125509RIVS	-
.71*	28	125510GV	125600GV	125510GV	125600GV
1	28	125510VS	125600VS	125510RIVS	125600RVS
1-1/4	28	125511VS	125601VS	125511RIVS	125601RVS
1-7/16	28	125512VS	125602VS	125512RIVS	125602RVS
1-1/2	28	125513VS	125603VS	125513RIVS	125603RVS

*Plain bore pilot hole. Not sized to a shaft.



Shaft Sized Bore Dia.	Teeth or Equivalent	Molded Single Key	Molded Double Key	Molded Square Shaft	Molded Split
		Part Number	Part Number	Part Number	Part Number
1-1/4	24	123190VS	123193VS	-	123197VS
1-7/16	24	123191VS	123194VS	-	123198VS
1-1/2	24	123192VS	123195VS	-	123199VS
1-1/2 x 1-1/2 sq.	28	-	-	123009VS	-
1-1/4	28	123000VS	123004VS	-	123010VS
1-7/16	28	123001VS	123005VS	-	123011VS
1-1/2	28	123002VS	123006VS	-	123012VS
1-3/4	28	123003VS	123007VS	-	123013VS

For delivery information, contact customer service.

See all sprockets and idlers on pages 101-125

Side Flexing Flat Top Chain-Belt

2250 TAB

Side Flexing Chain-Belts, TAB Guides

- High strength and heavy duty flight design.
- Chain thickness and hinge design ensure high working load capacity.
- Matching height to 2121 series belts allows for standardization of conveyor design.
- Optimum product stability. Top plate design and 1 inch pitch allows for a maximum support area and smooth product transfer.

Chain-Belts solve the problem of how to incorporate side flexing needs into a straight running modular belt application. Uses standard TAB style chain tracks or guides.

Chain-Belts are designed to have the same height above the wear surface as modular belts, and a solid surface that makes them suitable for glass bottles and PET bottles, especially those with low contact area bases.

Standard Length: 10ft.
Pitches: 120

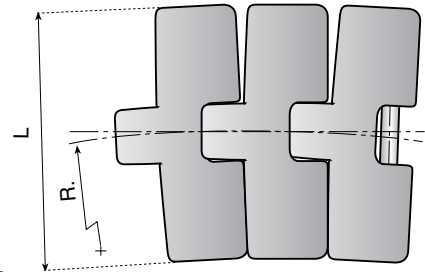
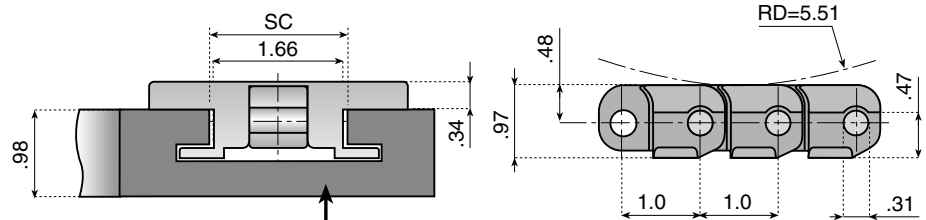
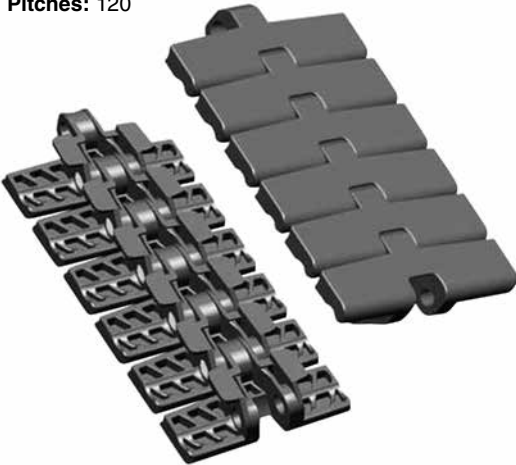

Use in combination with 2121 series belts

Material: "LFG Dark Grey" Low friction acetal with 304 stainless pins.

Chain Reference	Part Number	L (width)	R min.	SC Straight	SC Curved	Max Load (lbs.)	Weight (lbs. per ft.)
LFG2250FT-TAB-K330	11323	3.3	20	1.81	1.77	450	1.17
LFG2250FT-TAB-K450	11324	4.5	20	1.81	1.77	450	1.37

Material: "NGG Light Grey" Very low friction material with 304 stainless pins.

Chain Reference	Part Number	L (width)	R min.	SC Straight	SC Curved	Max Load (lbs.)	Weight (lbs. per ft.)
NGG2250FT-TAB-K330	11323NGG	3.3	20	1.81	1.77	450	1.17
NGG2250FT-TAB-K450	11324 NGG	4.5	20	1.81	1.77	450	1.37

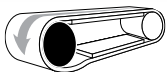

Drive Sprocket Options for 2250 Chain-Belts



Machined Split

Shaft Sized Bore Dia.	Teeth or Equivalent	Part Number
.71*	16	121017
1	16	321018
1-1/4	16	321019
1-7/16	16	321020
1-1/2	16	321021
.71*	18	121023
1	18	321024
1-1/4	18	321025
1-7/16	18	321026
1-1/2	18	321027
.71*	19	121029
1	19	321030
1-1/4	19	321031
1-7/16	19	321032
1-1/2	19	321033

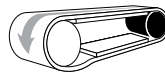

Idler Options for 2250 Chain-Belts



Machined Split

Part Number
-
321065
321066
321067
321068
-
321070
321071
321072
321073
-
321075
321076
321077
321078

See all sprockets and idlers on pages 101-125

Side Flexing Flat Top Chain-Belt

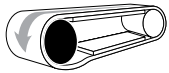

Drive Sprocket Options for 2250 TAB Chain-Belts

For delivery information, contact customer service.



Molded Single Key



Molded Double Key



Molded Square Shaft

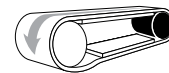

Idler Options for 2250 TAB Chain-Belts



Molded Split

Shaft Sized Bore Dia.	Teeth or Equivalent	Part Number	Part Number	Part Number	Part Number
1-1/2 x 1-1/2 sq.	16	-	-	123108S	-
1-1/4	16	123099S	123103S	-	123109S
1-7/16	16	123100S	123104S	-	123110S
1-1/2	16	123101S	123105S	-	123111S
1-3/4	16	123102S	123106S	-	123112S
1-1/2 x 1-1/2 sq.	18	-	-	123122S	-
1-1/4	18	123113S	123117S	-	123123S
1-7/16	18	123114S	123118S	-	123124S
1-1/2	18	123115S	123119S	-	123125S
1-3/4	18	123116S	123120S	-	123126S
1-1/2 x 1-1/2 sq.	19	-	-	123136S	-
1-1/4	19	123127S	123131S	-	123137S
1-7/16	19	123128S	123132S	-	123138S
1-1/2	19	123129S	123133S	-	123139S
1-3/4	19	123130S	123134S	-	123140S

See all sprockets and idlers on pages 101-125

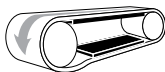

Track Options for 2250 TAB Chain-Belts

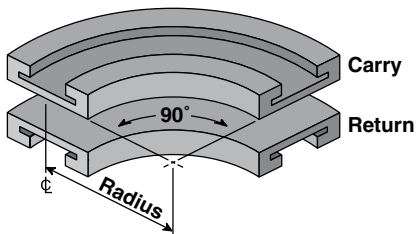

Corner Track

Part Number	Track Width	Radius (inches)
VT-980-T-18-0325	3.75	18
VT-980-T-24-0325	3.75	24
VT-980-T-24-0450	5.0	24

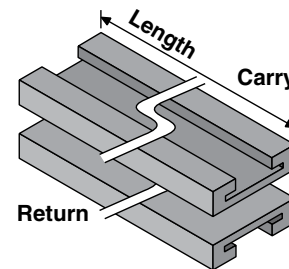

Straight Track

Part Number	Track Width	Length (feet)
VT-980-T-S-0325-3	3.75	3
VT-980-T-S-0325-6	3.75	6
VT-980-T-S-0325-10	3.75	10
VT-980-T-S-0450-3	5.0	3
VT-980-T-S-0450-6	5.0	6
VT-980-T-S-0450-10	5.0	10

See all ValuTrac modules on pages 130-145

Side Flexing Flat Top Chain-Belt

2250 M

Side Flexing Chain-Belts

- High strength and heavy duty flight design.
- Chain thickness and hinge design ensure high working load capacity.
- Matching height to 2121 series belts allows for standardization of conveyor design.
- Easy installation. No tabs or bevel. Allows chain to be installed and removed quickly.
- Optimum product stability. Top plate design and 1 inch pitch allows for a maximum support area and smooth product transfer.

Chain-Belts solve the problem of how to incorporate side flexing needs into a straight running modular belt application. For use with Dual Magnetic Corner Tracks.

Chain-Belts are designed to have the same height above the wear surface as modular belts, and a solid surface that makes them suitable for glass bottles and PET bottles, especially those with low contact area bases.

Standard Length: 10ft.
Pitches: 120

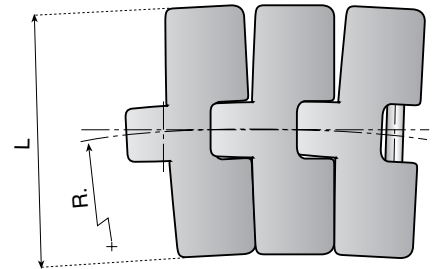
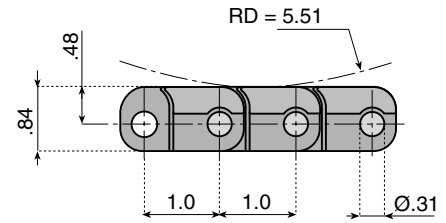
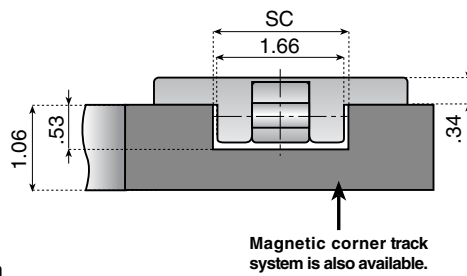
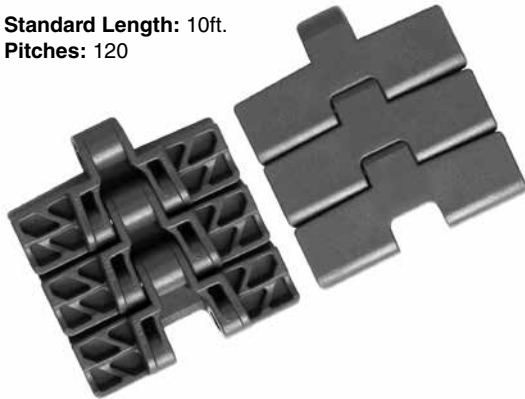

See page 146 for more information.

Use in combination with 2121 series belts

Material: "LFG Dark Grey" Low friction acetal with 304 stainless pins.

Chain Reference	Part Number	L (width)	R min.	SC Straight	SC Curved	Max Load (lbs.)	Weight (lbs. per ft.)
LFG 2250 M K330 FT	11320	3.3	20	1.77	1.73	450	1.18

Note: Replaced by 2260 series on page 86.

Material: "NGG Light Grey" Low friction material with 304 stainless pins.

Chain Reference	Part Number	L (width)	R min.	SC Straight	SC Curved	Max Load (lbs.)	Weight (lbs. per ft.)
NGG 2250 M K330 FT	11320NGG	3.3	20	1.77	1.73	450	1.18

Note: Replaced by NGG 2260 series on page 86.

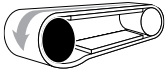

Drive Sprocket Options for 2250 M Chain-Belts



Machined Split

Shaft Sized Bore Dia.	Teeth or Equivalent	Part Number
.71*	16	121017
1	16	321018
1-1/4	16	321019
1-7/16	16	321020
1-1/2	16	321021
.71*	18	121023
1	18	321024
1-1/4	18	321025
1-7/16	18	321026
1-1/2	18	321027
.71*	19	121029
1	19	321030
1-1/4	19	321031
1-7/16	19	321032
1-1/2	19	321033

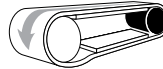

Idler Options for 2250 M Chain-Belts



Machined Split

Part Number
-
321065
321066
321067
321068
-
321070
321071
321072
321073
-
321075
321076
321077
321078

See all sprockets and idlers on pages 101-125

*Plain bore pilot hole. Not sized to a shaft.

Side Flexing Flat Top Chain-Belt

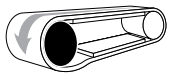

Drive Sprocket Options for 2250 M Chain-Belts

For delivery information, contact customer service.



Molded Single Key



Molded Double Key



Molded Square Shaft

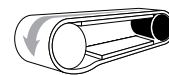

Idler Options for 2250 M Chain-Belts



Molded Split

Shaft Sized Bore Dia.	Teeth or Equivalent	Part Number	Part Number	Part Number	Part Number
1-1/2 x 1-1/2 sq.	16	-	-	123108S	-
1-1/4	16	123099S	123103S	-	123109S
1-7/16	16	123100S	123104S	-	123110S
1-1/2	16	123101S	123105S	-	123111S
1-3/4	16	123102S	123106S	-	123112S
1-1/2 x 1-1/2 sq.	18	-	-	123122S	-
1-1/4	18	123113S	123117S	-	123123S
1-7/16	18	123114S	123118S	-	123124S
1-1/2	18	123115S	123119S	-	123125S
1-3/4	18	123116S	123120S	-	123126S
1-1/2 x 1-1/2 sq.	19	-	-	123136S	-
1-1/4	19	123127S	123131S	-	123137S
1-7/16	19	123128S	123132S	-	123138S
1-1/2	19	123129S	123133S	-	123139S
1-3/4	19	123130S	123134S	-	123140S

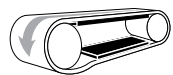

Track Options for 2250 M Chain-Belts K330 Series

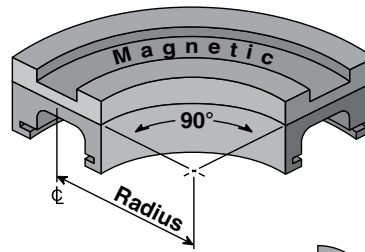

See all sprockets and idlers on pages 101-125

Number of Tracks	Total Width		Angle					
	mm	inches	15°	30°	45°	60°	75°	90°
1	100	3.94	KMD.15.15.01.A	KMD.15.30.01.A	KMD.15.45.01.A	KMD.15.60.01.A	KMD.15.75.01.A	KMD.15.90.01.A
2	185	7.28	KMD.15.15.02.A	KMD.15.30.02.A	KMD.15.45.02.A	KMD.15.60.02.A	KMD.15.75.02.A	KMD.15.90.02.A
3	270	10.63	KMD.15.15.03.A	KMD.15.30.03.A	KMD.15.45.03.A	KMD.15.60.03.A	KMD.15.75.03.A	KMD.15.90.03.A
4	355	13.98	KMD.15.15.04.A	KMD.15.30.04.A	KMD.15.45.04.A	KMD.15.60.04.A	KMD.15.75.04.A	KMD.15.90.04.A

For additional number of tracks in a magnetic curve, see the chain track catalog section.

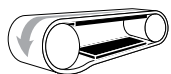

Track Options for 2250 M Chain-Belts K450 Series

See all Magnetic Corner Tracks on pages 146-153

Number of Tracks	Total Width		Angle					
	mm	inches	15°	30°	45°	60°	75°	90°
1	129	5.08	KMD.56.15.01.A	KMD.56.30.01.A	KMD.56.45.01.A	KMD.56.60.01.A	KMD.56.75.01.A	KMD.56.90.01.A
2	246	9.69	KMD.56.15.02.A	KMD.56.30.02.A	KMD.56.45.02.A	KMD.56.60.02.A	KMD.56.75.02.A	KMD.56.90.02.A
3	363	14.29	KMD.56.15.03.A	KMD.56.30.03.A	KMD.56.45.03.A	KMD.56.60.03.A	KMD.56.75.03.A	KMD.56.90.03.A
4	480	18.90	KMD.56.15.04.A	KMD.56.30.04.A	KMD.56.45.04.A	KMD.56.60.04.A	KMD.56.75.04.A	KMD.56.90.04.A

Side Flexing Flat Top Chain-Belt

2260 M

Side Flexing Flat Top Chain-Belts

- High strength and heavy duty flight design.
- Chain thickness and hinge design ensure high working load capacity.
- Matching height to 2121 series belts allows for standardization of conveyor design.
- Optimum product stability. Top plate design and 1 inch pitch allows for a maximum support area and smooth product transfer.

Chain-Belts solve the problem of how to incorporate side flexing needs into a straight running modular belt application. For use with Dual Magnetic Corner Tracks.

Chain-Belts are designed to have the same height above the wear surface as modular belts, and a solid surface that makes them suitable for glass bottles and PET bottles, especially those with low contact area bases.

Standard Length: 10ft.
Pitches: 120

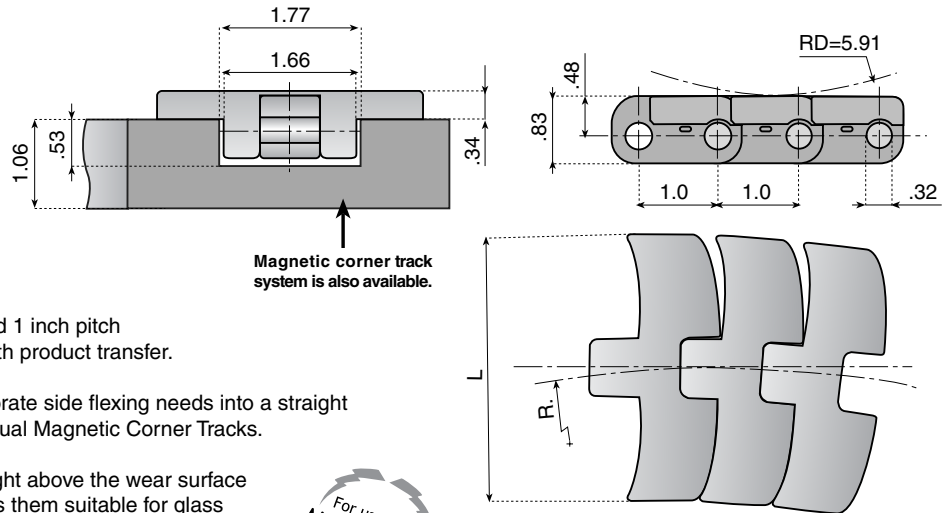
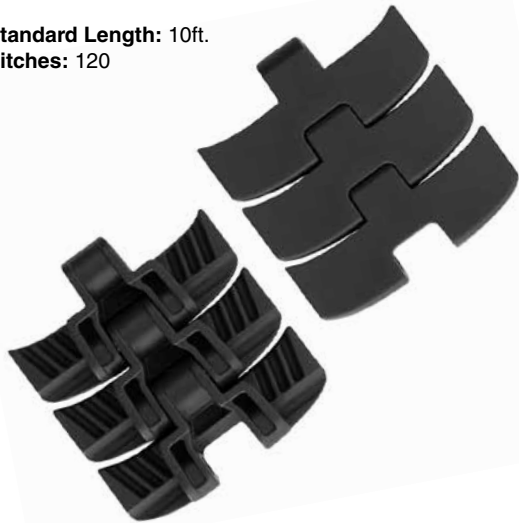

See page 146 for more information.

Use in combination with 2121 series belts

Material: "LFG Dark Grey" Low friction acetal with 304 stainless pins.

Chain Reference	Part Number	L (width)	R min.	Max Load (lbs.)	Weight (lbs. per ft.)
LFG2260FT-M-K330	11329	3.3	20	450	1.17

Material: "NGG Light Grey" Very low friction material with 304 stainless pins.

Chain Reference	Part Number	L (width)	R min.	Max Load (lbs.)	Weight (lbs. per ft.)
NGG2260FT-M-K330	11329NGG	3.3	20	450	1.17

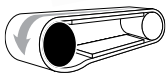

Drive Sprocket Options for 2260 M Chain-Belts



Machined Split

Shaft Sized Bore Dia.	Teeth or Equivalent	Part Number
.71*	16	121017
1	16	321018
1-1/4	16	321019
1-7/16	16	321020
1-1/2	16	321021
.71*	18	121023
1	18	321024
1-1/4	18	321025
1-7/16	18	321026
1-1/2	18	321027
.71*	19	121029
1	19	321030
1-1/4	19	321031
1-7/16	19	321032
1-1/2	19	321033

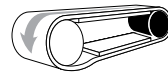

Idler Options for 2260 M Chain-Belts



Machined Split

Part Number
-
321065
321066
321067
321068
-
321070
321071
321072
321073
-
321075
321076
321077
321078

See all sprockets and idlers on pages 101-125

*Plain bore pilot hole. Not sized to a shaft.

Side Flexing Flat Top Chain-Belt

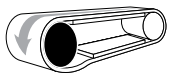

Drive Sprocket Options for 2260 M Chain-Belts

For delivery information, contact customer service.



Molded Single Key



Molded Double Key



Molded Square Shaft

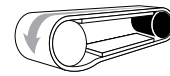

Idler Options for 2260 M FT Chain-Belts



Molded Split

Shaft Sized Bore Dia.	Teeth or Equivalent	Part Number	Part Number	Part Number	Part Number
1-1/2 x 1-1/2 sq.	16	-	-	123108S	-
1-1/4	16	123099S	123103S	-	123109S
1-7/16	16	123100S	123104S	-	123110S
1-1/2	16	123101S	123105S	-	123111S
1-3/4	16	123102S	123106S	-	123112S
1-1/2 x 1-1/2 sq.	18	-	-	123122S	-
1-1/4	18	123113S	123117S	-	123123S
1-7/16	18	123114S	123118S	-	123124S
1-1/2	18	123115S	123119S	-	123125S
1-3/4	18	123116S	123120S	-	123126S
1-1/2 x 1-1/2 sq.	19	-	-	123136S	-
1-1/4	19	123127S	123131S	-	123137S
1-7/16	19	123128S	123132S	-	123138S
1-1/2	19	123129S	123133S	-	123139S
1-3/4	19	123130S	123134S	-	123140S

See all sprockets and idlers on pages 101-125

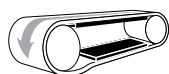

Track Options for 2260 M Chain-Belts / K330 Series

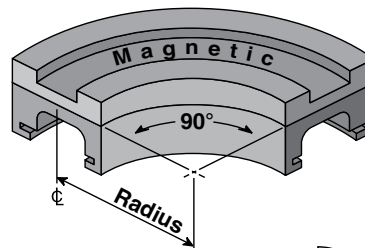

Number of Tracks	Total Width		Angle					
	mm	inches	15°	30°	45°	60°	75°	90°
1	100	3.94	KMD.15.15.01.A	KMD.15.30.01.A	KMD.15.45.01.A	KMD.15.60.01.A	KMD.15.75.01.A	KMD.15.90.01.A
2	185	7.28	KMD.15.15.02.A	KMD.15.30.02.A	KMD.15.45.02.A	KMD.15.60.02.A	KMD.15.75.02.A	KMD.15.90.02.A
3	270	10.63	KMD.15.15.03.A	KMD.15.30.03.A	KMD.15.45.03.A	KMD.15.60.03.A	KMD.15.75.03.A	KMD.15.90.03.A
4	355	13.98	KMD.15.15.04.A	KMD.15.30.04.A	KMD.15.45.04.A	KMD.15.60.04.A	KMD.15.75.04.A	KMD.15.90.04.A

For additional number of tracks in a magnetic curve, see the chain track catalog section.

See all Magnetic Corner Tracks on pages 146-153

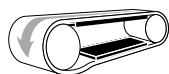

Track Options for 2260 M Chain-Belts / K450 Series

Number of Tracks	Total Width		Angle					
	mm	inches	15°	30°	45°	60°	75°	90°
1	129	5.08	KMD.56.15.01.A	KMD.56.30.01.A	KMD.56.45.01.A	KMD.56.60.01.A	KMD.56.75.01.A	KMD.56.90.01.A
2	246	9.69	KMD.56.15.02.A	KMD.56.30.02.A	KMD.56.45.02.A	KMD.56.60.02.A	KMD.56.75.02.A	KMD.56.90.02.A
3	363	14.29	KMD.56.15.03.A	KMD.56.30.03.A	KMD.56.45.03.A	KMD.56.60.03.A	KMD.56.75.03.A	KMD.56.90.03.A
4	480	18.90	KMD.56.15.04.A	KMD.56.30.04.A	KMD.56.45.04.A	KMD.56.60.04.A	KMD.56.75.04.A	KMD.56.90.04.A

Flat Top Belts

2252

Straight Running Belts with Single Piece Widths

- 1 inch pitch
- 1/2 inch height
- Easy installation and maintenance
- High mechanical strength and wear resistance
- No gaps between parallel chains
- Excellent product handling

System Plast Flat Top Belts have a solid surface that makes them suitable for glass bottles and PET bottles, especially those with low contact area bases.

Standard Length: 10ft.
Pitches: 120

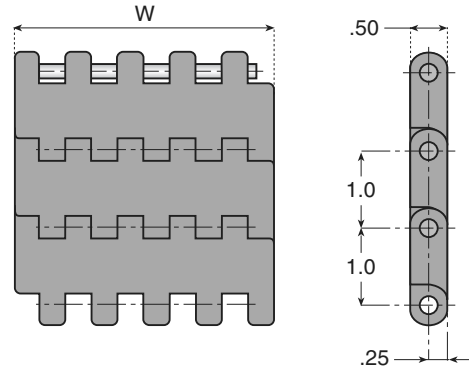
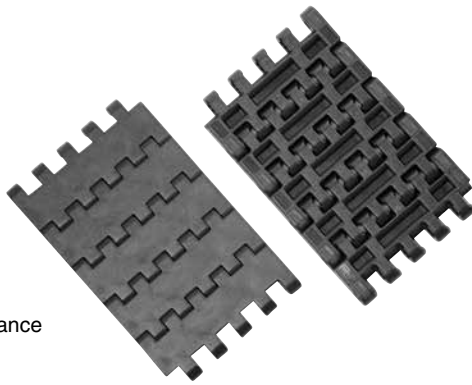

Material: "LFG Dark Grey" Low friction acetal chain. White PBT pins.

Chain Reference	Part Number	W (width)	Pitch	Backflex Radius	Max Load* (lbs. per ft.)	Weight (lbs. per sq. ft.)
LFG2252FT-K300	26000	3	1.0	1.0	2604	2.87
LFG2252FT-K325	26001	3-1/4	1.0	1.0	2604	2.87
LFG2252FT-K450	26002	4-1/2	1.0	1.0	2604	2.87
LFG2252FT-K600	26003	6	1.0	1.0	2604	2.87
LFG2252FT-K750	26004	7-1/2	1.0	1.0	2604	2.87

*Max. load changes according to belt width. Example: max. load for a 6 inch wide belt is half of the lbs. per foot figure shown.

Straight Running Belts with Single Piece Widths and Two Positioners

- 1 inch pitch
- 1/2 inch height
- Easy installation and maintenance
- High mechanical strength and wear resistance
- No gaps between parallel chains
- Excellent product handling

System Plast Flat Top Belts have a solid surface that makes them suitable for glass bottles and PET bottles, especially those with a low contact area base.

Standard Length: 10ft.
Pitches: 120

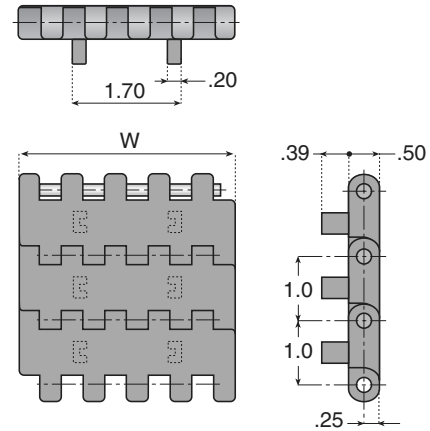
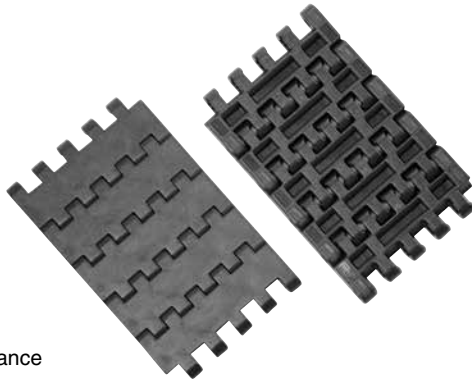

Material: "LFG Dark Grey" Low friction acetal chain. White PBT pins.

Chain Reference	Part Number	W (width)	Pitch	Backflex Radius	Max Load* (lbs. per ft.)	Weight (lbs. per sq. ft.)
LFG2252FT-PT-K300	26010	3	1.0	1.0	2604	2.89
LFG2252FT-PT-K325	26011	3-1/4	1.0	1.0	2604	2.89
LFG2252FT-PT-K450	26012	4-1/2	1.0	1.0	2604	2.89
LFG2252FT-PT-K600	26013	6	1.0	1.0	2604	2.89
LFG2252FT-PT-K750	26014	7-1/2	1.0	1.0	2604	2.89

*Max. load changes according to belt width. Example: max. load for a 6 inch wide belt is half of the lbs. per foot figure shown.

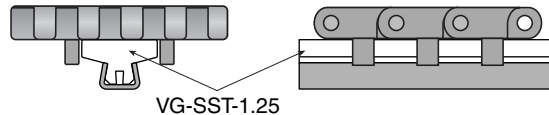

For delivery information, contact customer service.

Flat Top Belts

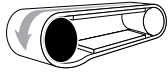

Drive Sprocket Options for 2252 Flat Top Belts



Machined Split

Shaft Sized Bore Dia.	Teeth or Equivalent	Part Number
.71*	16	125250GF
1	16	125250S
1-1/4	16	125251S
1-7/16	16	125252S
1-1/2	16	125253S
.71*	18	125254GF
1	18	125254S
1-1/4	18	125255S
1-7/16	18	125256S
1-1/2	18	125257S
.71*	20	125258GF
1	20	125258S
1-1/4	20	125259S
1-7/16	20	125260S
1-1/2	20	125261S
.71*	21	125262GF
1	21	125262S
1-1/4	21	125263S
1-7/16	21	125264S
1-1/2	21	125265S

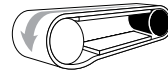

Idler Options for 2252 Flat Top Belts



Machined Split

Part Number
125250GF
125250RS
125251RS
125252RS
125253RS
125254GF
125254RS
125255RS
125256RS
125257RS
125258GF
125258RS
125259RS
125260RS
125261RS
125262GF
125262RS
125263RS
125264RS
125265RS

*Plain bore pilot hole. Not sized to a shaft.

**For delivery
information, contact
customer service.**



Molded Single Key



Molded Double Key



Molded Square Shaft



Molded Split

See all sprockets
and idlers on
pages 101-125

Shaft Sized Bore Dia.	Teeth or Equivalent	Part Number	Part Number	Part Number	Part Number
1-1/4	14	123150S	123154S	-	123162S
1-7/16	14	123151S	123155S	-	123163S
1-1/2	14	123152S	123156S	-	123164S
1-1/2 x 1-1/2 sq.	16	-	-	123066S	-
1-1/4	16	123057S	123061S	-	123067S
1-7/16	16	123058S	123062S	-	123068S
1-1/2	16	123059S	123063S	-	123069S
1-3/4	16	123060S	123064S	-	123070S
1-1/2 x 1-1/2 sq.	18	-	-	123080S	-
1-1/4	18	123071S	123075S	-	123081S
1-7/16	18	123072S	123076S	-	123082S
1-1/2	18	123073S	123077S	-	123083S
1-3/4	18	123074S	123078S	-	123084S
1-1/2 x 1-1/2 sq.	20	-	-	123094S	-
1-1/4	20	123085S	123089S	-	123095S
1-7/16	20	123086S	123090S	-	123096S
1-1/2	20	123087S	123091S	-	123097S
1-3/4	20	123088S	123092S	-	123098S

Flat Top Belts

2252 FT

Straight Running Belts with Combined Piece Widths

- 1 inch pitch
- 1/2 inch height
- Easy installation and maintenance
- High mechanical strength and wear resistance
- No gaps between parallel chains
- Excellent product handling

System Plast Flat Top Belts have a solid surface that makes them suitable for glass bottles and PET bottles, especially those with a low contact area base.

Standard Length: 10ft.
Pitches: 120

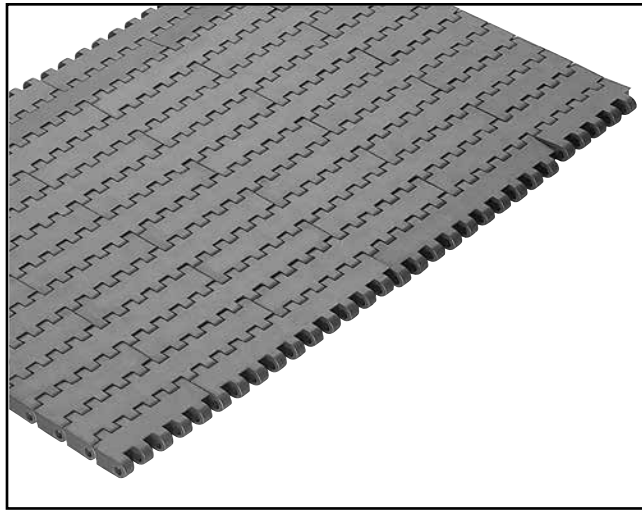
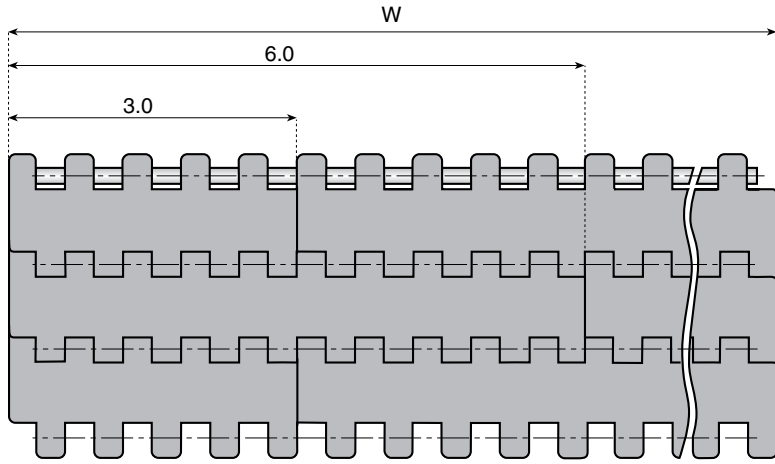

For delivery information, contact customer service.

Material: "LFG Dark Grey" Low friction acetal chain. White PBT pins. For "XPG Dark Brown" material, add "XPG" to the end of the part number, example: **261002XPG**.

Chain Reference	Part Number	Width (in.)	Backflex Radius	Max Load* (lbs. per ft.)	Weight (lbs. per sq. ft.)
LFG2252FT-K900	261002	9	1.0	2604	2.87
LFG2252FT-K1200	261003	12	1.0	2604	2.87
LFG2252FT-K1500	261004	15	1.0	2604	2.87
LFG2252FT-K1800	261005	18	1.0	2604	2.87
LFG2252FT-K2100	261006	21	1.0	2604	2.87
LFG2252FT-K2400	261007	24	1.0	2604	2.87
LFG2252FT-K2700	261008	27	1.0	2604	2.87
LFG2252FT-K3000	261009	30	1.0	2604	2.87
LFG2252FT-K3300	261010	33	1.0	2604	2.87
LFG2252FT-K3600	261011	36	1.0	2604	2.87
LFG2252FT-K3900	261012	39	1.0	2604	2.87
LFG2252FT-K4200	261013	42	1.0	2604	2.87
LFG2252FT-K4500	261014	45	1.0	2604	2.87
LFG2252FT-K4800	261015	48	1.0	2604	2.87
LFG2252FT-K5100	261016	51	1.0	2604	2.87
LFG2252FT-K5400	261017	54	1.0	2604	2.87
LFG2252FT-K5700	261018	57	1.0	2604	2.87
LFG2252FT-K6000	261019	60	1.0	2604	2.87

*Max. load changes according to belt width. Example: max. load for a 24 inch wide belt is 2 times the lbs. per foot figure shown.

Flat Top Belts

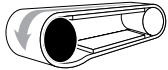

Drive Sprocket Options for 2252 FT Flat Top Belts



Machined Split

Shaft Sized Bore Dia.	Teeth or Equivalent	Part Number
.71*	16	125250GF
1	16	125250S
1-1/4	16	125251S
1-7/16	16	125252S
1-1/2	16	125253S
.71*	18	125254GF
1	18	125254S
1-1/4	18	125255S
1-7/16	18	125256S
1-1/2	18	125257S
.71*	20	125258GF
1	20	125258S
1-1/4	20	125259S
1-7/16	20	125260S
1-1/2	20	125261S
.71*	21	125262GF
1	21	125262S
1-1/4	21	125263S
1-7/16	21	125264S
1-1/2	21	125265S

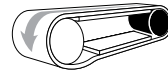

Idler Options for 2252 FT Flat Top Belts



Machined Split

Part Number
125250GF
125250RS
125251RS
125252RS
125253RS
125254GF
125254RS
125255RS
125256RS
125257RS
125258GF
125258RS
125259RS
125260RS
125261RS
125262GF
125262RS
125263RS
125264RS
125265RS

*Plain bore pilot hole. Not sized to a shaft.

For delivery information, contact customer service.



Molded Single Key



Molded Double Key



Molded Square Shaft



Molded Split

See all sprockets and idlers on pages 101-125

Shaft Sized Bore Dia.	Teeth or Equivalent	Part Number	Part Number	Part Number	Part Number
1-1/4	14	123150S	123154S	-	123162S
1-7/16	14	123151S	123155S	-	123163S
1-1/2	14	123152S	123156S	-	123164S
1-1/2 x 1-1/2 sq.	16	-	-	123066S	-
1-1/4	16	-	123061S	-	123067S
1-7/16	16	123058S	123062S	-	123068S
1-1/2	16	123059S	123063S	-	123069S
1-3/4	16	123060S	123064S	-	123070S
1-1/2 x 1-1/2 sq.	18	-	-	123080S	-
1-1/4	18	123071S	123075S	-	123081S
1-7/16	18	123072S	123076S	-	123082S
1-1/2	18	123073S	123077S	-	123070S
1-3/4	18	123074S	123078S	-	123071S
1-1/2 x 1-1/2 sq.	20	-	-	123094S	-
1-1/4	20	123085S	123089S	-	123095S
1-7/16	20	123086S	123090S	-	123096S
1-1/2	20	123087S	123091S	-	123097S
1-3/4	20	123088S	123092S	-	123098S

Flat Top Belts

2252 PT

Straight Running Belts with Combined Piece Widths

- 1 inch pitch
- 1/2 inch height
- Easy installation and maintenance
- High mechanical strength and wear resistance
- No gaps between parallel chains
- Excellent product handling

System Plast Flat Top Belts have a solid surface that makes them suitable for glass bottles and PET bottles, especially those with a low contact area base.

Standard Length: 10ft.
Pitches: 120

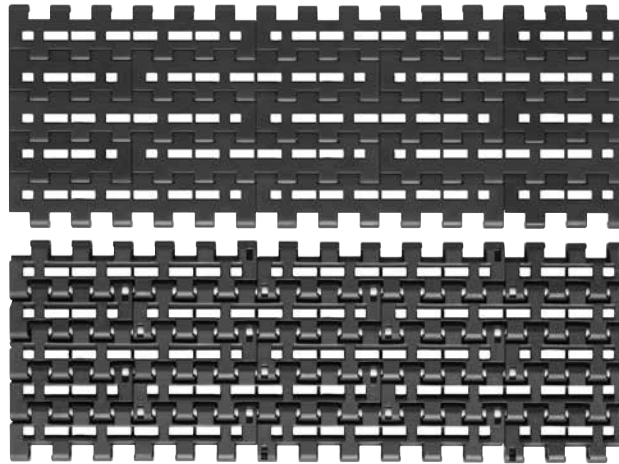
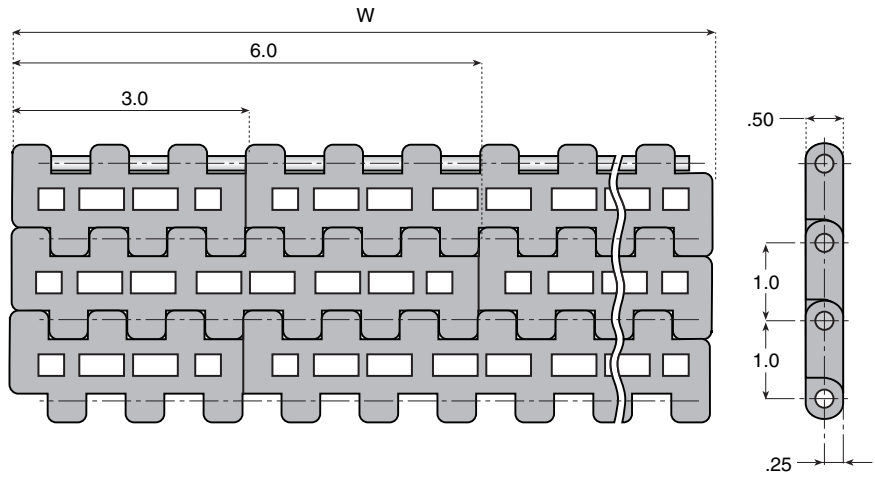

For delivery information, contact customer service.

Material: "LFG Dark Grey" Low friction acetal chain. White PBT pins. For "XPG Dark Brown" material, add "XPG" to the end of the part number, example: 26200XPG.

Chain Reference	Part Number	Width (in.)	Backflex Radius	Max Load* (lbs. per ft.)	Weight (lbs. per sq. ft.)
LFG2252PT-K300	26200	3	1.0	2604	2.72
LFG2252PT-K600	26201	6	1.0	2604	2.72
LFG2252PT-K900	26202	9	1.0	2604	2.72
LFG2252PT-K1200	26203	12	1.0	2604	2.72
LFG2252PT-K1500	26204	15	1.0	2604	2.72
LFG2252PT-K1800	26205	18	1.0	2604	2.72
LFG2252PT-K2100	26206	21	1.0	2604	2.72
LFG2252PT-K2400	26207	24	1.0	2604	2.72
LFG2252PT-K2700	26208	27	1.0	2604	2.72
LFG2252PT-K3000	26209	30	1.0	2604	2.72
LFG2252PT-K3300	26210	33	1.0	2604	2.72
LFG2252PT-K3600	26211	36	1.0	2604	2.72
LFG2252PT-K3900	26212	39	1.0	2604	2.72
LFG2252PT-K4200	26213	42	1.0	2604	2.72
LFG2252PT-K4500	26214	45	1.0	2604	2.72
LFG2252PT-K4800	26215	48	1.0	2604	2.72
LFG2252PT-K5100	26216	51	1.0	2604	2.72
LFG2252PT-K5400	26217	54	1.0	2604	2.72
LFG2252PT-K5700	26218	57	1.0	2604	2.72
LFG2252PT-K6000	26219	60	1.0	2604	2.72

*Max. load changes according to belt width. Example: max. load for a 24 inch wide belt is 2 times the lbs. per foot figure shown.

Flat Top Belts

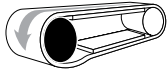

Drive Sprocket Options for 2252 PT Flat Top Belts



Machined Split

Shaft Sized Bore Dia.	Teeth or Equivalent	Part Number
.71*	16	125250GF
1	16	125250S
1-1/4	16	125251S
1-7/16	16	125252S
1-1/2	16	125253S
.71*	18	125254GF
1	18	125254S
1-1/4	18	125255S
1-7/16	18	125256S
1-1/2	18	125257S
.71*	20	125258GF
1	20	125258S
1-1/4	20	125259S
1-7/16	20	125260S
1-1/2	20	125261S
.71*	21	125262GF
1	21	125262S
1-1/4	21	125263S
1-7/16	21	125264S
1-1/2	21	125265S

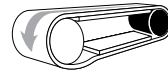

Idler Options for 2252 PT Flat Top Belts



Machined Split

Part Number
125250GF
125250RS
125251RS
125252RS
125253RS
125254GF
125254RS
125255RS
125256RS
125257RS
125258GF
125258RS
125259RS
125260RS
125261RS
125262GF
125262RS
125263RS
125264RS
125265RS

*Plain bore pilot hole. Not sized to a shaft.

For delivery information, contact customer service.



Molded Single Key



Molded Double Key



Molded Square Shaft



Molded Split

See all sprockets and idlers on pages 101-125

Shaft Sized Bore Dia.	Teeth or Equivalent	Part Number	Part Number	Part Number	Part Number
1-1/4	14	123150S	123154S	-	123162S
1-7/16	14	123151S	123155S	-	123163S
1-1/2	14	123152S	123156S	-	123164S
1-1/2 x 1-1/2 sq.	16	-	-	123066S	-
1-1/4	16	-	123061S	-	123067S
1-7/16	16	123058S	123062S	-	123068S
1-1/2	16	123059S	123063S	-	123069S
1-3/4	16	123060S	123064S	-	123070S
1-1/2 x 1-1/2 sq.	18	-	-	123080S	-
1-1/4	18	123071S	123075S	-	123081S
1-7/16	18	123072S	123076S	-	123082S
1-1/2	18	123073S	123077S	-	123070S
1-3/4	18	123074S	123078S	-	123071S
1-1/2 x 1-1/2 sq.	20	-	-	123094S	-
1-1/4	20	123085S	123089S	-	123095S
1-7/16	20	123086S	123090S	-	123096S
1-1/2	20	123087S	123091S	-	123097S
1-3/4	20	123088S	123092S	-	123098S

Flat Top Belts with Rollers

LBP 2251

Flat Top Belts with Accumulation Rollers

- Easy installation and maintenance
- Optimum product stability
- High performance
- Easy to clean
- Long wear life
- Low noise rollers

Standard Length: 5ft.
Pitches: 60

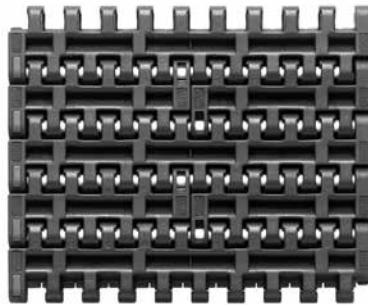
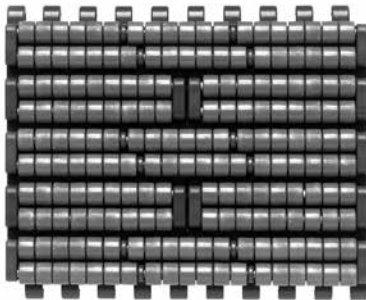
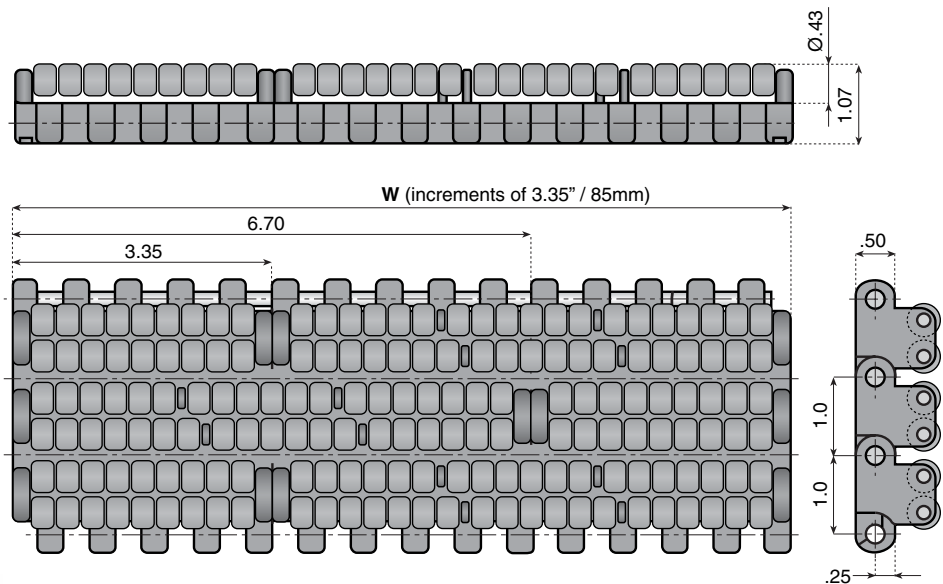

For delivery information, contact customer service.

Material: "LF Dark Grey" Low friction acetal belt. Water blue acetal resin rollers with stainless steel roller shaft.

Chain Reference	Width (mm)	Part Number	Backflex Radius	Max Load* (lbs. per ft.)	Weight (lbs. per sq. ft.)
LFG2251LBP-M0085		251800	4.75	2604	5.98
LFG2251LBP-M0170		251801	4.75	2604	5.98
LFG2251LBP-M0255		251802	4.75	2604	5.98
LFG2251LBP-M0340		251803	4.75	2604	5.98
LFG2251LBP-M0425		251804	4.75	2604	5.98
LFG2251LBP-M0510		251805	4.75	2604	5.98
LFG2251LBP-M0595		251806	4.75	2604	5.98
LFG2251LBP-M0680		251807	4.75	2604	5.98
LFG2251LBP-M0765		251808	4.75	2604	5.98
LFG2251LBP-M0850		251809	4.75	2604	5.98
LFG2251LBP-M0935		251810	4.75	2604	5.98
LFG2251LBP-M1020		251811	4.75	2604	5.98
LFG2251LBP-M1105		251812	4.75	2604	5.98
LFG2251LBP-M1190		251813	4.75	2604	5.98
LFG2251LBP-M1275		251814	4.75	2604	5.98
LFG2251LBP-M1360		251815	4.75	2604	5.98
LFG2251LBP-M1445		251816	4.75	2604	5.98
LFG2251LBP-M1530		251817	4.75	2604	5.98

*Max. load changes according to belt width. Example: max. load for a 24 inch wide belt is 2 times the lbs. per foot figure shown.

Flat Top Belts with Rollers

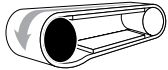

Drive Sprocket Options for LBP 2251 Flat Top Belts



Machined Split

Shaft Sized Bore Dia.	Teeth or Equivalent	Part Number
.71*	16	125250GF
1	16	125250S
1-1/4	16	125251S
1-7/16	16	125252S
1-1/2	16	125253S
.71*	18	125254GF
1	18	125254S
1-1/4	18	125255S
1-7/16	18	125256S
1-1/2	18	125257S
.71*	20	125258GF
1	20	125258S
1-1/4	20	125259S
1-7/16	20	125260S
1-1/2	20	125261S
.71*	21	125262GF
1	21	125262S
1-1/4	21	125263S
1-7/16	21	125264S
1-1/2	21	125265S

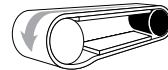

Idler Options for LBP 2251 Flat Top Belts



Machined Split

Part Number
125250GF
125250RS
125251RS
125252RS
125253RS
125254GF
125254RS
125255RS
125256RS
125257RS
125258GF
125258RS
125259RS
125260RS
125261RS
125262GF
125262RS
125263RS
125264RS
125265RS

*Plain bore pilot hole. Not sized to a shaft.

For delivery information, contact customer service.



Molded Single Key



Molded Double Key



Molded Square Shaft



Molded Split

Shaft Sized Bore Dia.	Teeth or Equivalent	Part Number	Part Number	Part Number	Part Number
1-1/4	14	123150S	123154S	-	123162S
1-7/16	14	123151S	123155S	-	123163S
1-1/2	14	123152S	123156S	-	123164S
1-1/2 x 1-1/2 sq.	16	-	-	123066S	-
1-1/4	16	-	123061S	-	123067S
1-7/16	16	123058S	123062S	-	123068S
1-1/2	16	123059S	123063S	-	123069S
1-3/4	16	123060S	123064S	-	123070S
1-1/2 x 1-1/2 sq.	18	-	-	123080S	-
1-1/4	18	123071S	123075S	-	123081S
1-7/16	18	123072S	123076S	-	123082S
1-1/2	18	123073S	123077S	-	123070S
1-3/4	18	123074S	123078S	-	123071S
1-1/2 x 1-1/2 sq.	20	-	-	123094S	-
1-1/4	20	123085S	123089S	-	123095S
1-7/16	20	123086S	123090S	-	123096S
1-1/2	20	123087S	123091S	-	123097S
1-3/4	20	123088S	123092S	-	123098S

See all sprockets and idlers on pages 101-125

Side Flexing Flat Top Chain-Belt

2251 TAB

Side Flexing Chain-Belts, TAB Guides

- High strength and heavy duty flight design.
- Chain thickness and hinge design ensure high working load capacity.
- Matching height to 2252 series belts allows for standardization of conveyor design.
- Optimum product stability. Top plate design and 1 inch pitch allows for a maximum support area and smooth product transfer.

Chain-Belts solve the problem of how to incorporate side flexing needs into a straight running modular belt application. Uses standard TAB style chain tracks or guides.

Chain-Belts are designed to have the same height above the wear surface as modular belts, and a solid surface that makes them suitable for glass bottles and PET bottles, especially those with low contact area bases.

Standard Length: 10ft.
Pitches: 120

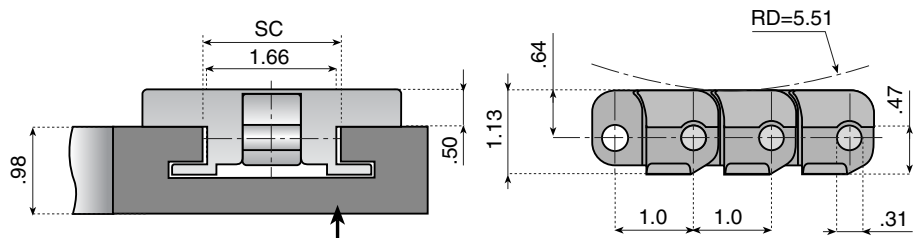

Standard tracks for TAB system or ValuTrac II system.

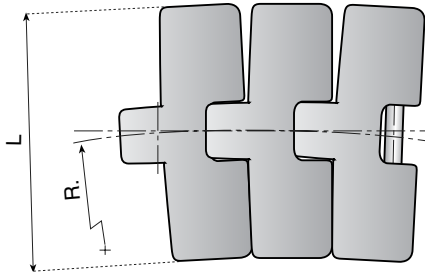

Use in combination with 2252 series belts

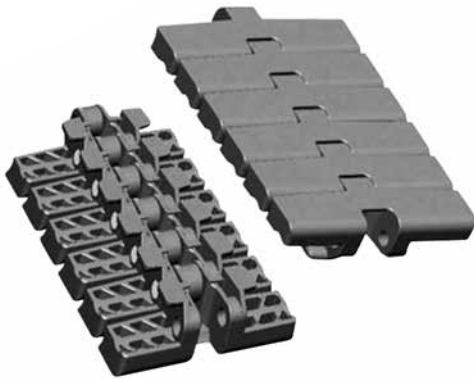

Material: "LFG Dark Grey" Low friction acetal with 304 stainless pins.

Chain Reference	Part Number	L (width)	R min.	SC Straight	SC Curved	Max Load (lbs.)	Weight (lbs. per sq. ft.)
LFG2251FT-TAB-K330	11325	3.3	20	1.81	1.77	450	1.28

Material: "NGG Light Grey" Very low friction material with 304 stainless pins.

Chain Reference	Part Number	L (width)	R min.	SC Straight	SC Curved	Max Load (lbs.)	Weight (lbs. per sq. ft.)
NGG2251FT-TAB-K330	11325NGG	3.3	20	1.81	1.77	450	1.28
NGG2251FT-TAB-K450	11326NGG	4.5	20	1.81	1.77	450	1.28

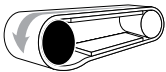

Drive Sprocket Options for 2251 TAB Chain-Belts



Machined Split

Shaft Sized Bore Dia.	Teeth or Equivalent	Part Number
.71*	16	121017
1	16	321018
1-1/4	16	321019
1-7/16	16	321020
1-1/2	16	-
.71*	18	121023
1	18	321024
1-1/4	18	321025
1-7/16	18	321026
1-1/2	18	321027
.71*	19	121029
1	19	321030
1-1/4	19	321031
1-7/16	19	321032
1-1/2	19	321033

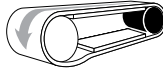

Idler Options for 2251 TAB Chain-Belts



Machined Split

Part Number
-
321065
321066
321067
321068
-
321070
321071
321072
321073
-
321075
321076
321077
321078

See all sprockets and idlers on pages 101-125

*Plain bore pilot hole. Not sized to a shaft.

Side Flexing Flat Top Chain-Belt

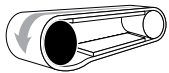

Drive Sprocket Options for 2251 TAB Chain-Belts

For delivery information, contact customer service.



Molded Single Key



Molded Double Key



Molded Square Shaft

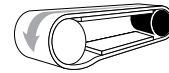

Idler Options for 2251 TAB Chain-Belts



Molded Split

Shaft Sized Bore Dia.	Teeth or Equivalent	Part Number	Part Number	Part Number	Part Number
1-1/2 x 1-1/2 sq.	16	-	-	123108S	-
1-1/4	16	123099S	123103S	-	123109S
1-7/16	16	123100S	123104S	-	123110S
1-1/2	16	123101S	123105S	-	123111S
1-3/4	16	123102S	123106S	-	123112S
1-1/2 x 1-1/2 sq.	18	-	-	123122S	-
1-1/4	18	123113S	123117S	-	123123S
1-7/16	18	123114S	123118S	-	123124S
1-1/2	18	123115S	123119S	-	123125S
1-3/4	18	123116S	123120S	-	123126S
1-1/2 x 1-1/2 sq.	19	-	-	123136S	-
1-1/4	19	123127S	123131S	-	123137S
1-7/16	19	123128S	123132S	-	123138S
1-1/2	19	123129S	123133S	-	123139S
1-3/4	19	123130S	123134S	-	123140S

See all sprockets and idlers on pages 101-125

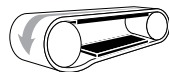

Track Options for 2251 TAB Chain-Belts

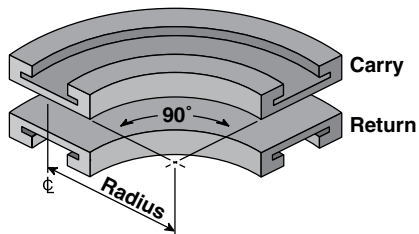

Corner Track

Part Number	Track Width	Radius (inches)
VT-980-T-18-0325	3.75	18
VT-980-T-24-0325	3.75	24
VT-980-T-24-0450	5.0	24

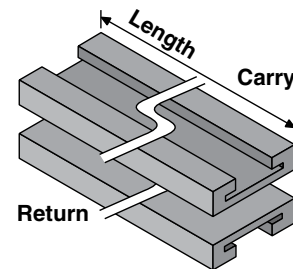

Straight Track

Part Number	Track Width	Length (feet)
VT-980-T-S-0325-3	3.75	3
VT-980-T-S-0325-6	3.75	6
VT-980-T-S-0325-10	3.75	10
VT-980-T-S-0450-3	5.0	3
VT-980-T-S-0450-6	5.0	6
VT-980-T-S-0450-10	5.0	10

See all ValuTrac modules on pages 130-145

Side Flexing Flat Top Chain-Belt

2251 M

Side Flexing Chain-Belts

- High strength and heavy duty flight design.
- Chain thickness and hinge design ensure high working load capacity.
- Matching height to 2252 series belts allows for standardization of conveyor design.
- Optimum product stability. Top plate design and 1 inch pitch allows for a maximum support area and smooth product transfer.

Chain-Belts solve the problem of how to incorporate side flexing needs into a straight running modular belt application. For use with Dual Magnetic Corner Tracks.

Chain-Belts are designed to have the same height above the wear surface as modular belts, and a solid surface that makes them suitable for glass bottles and PET bottles, especially those with low contact area bases.

Standard Length: 10ft.
Pitches: 120

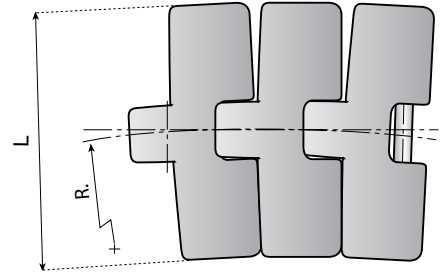
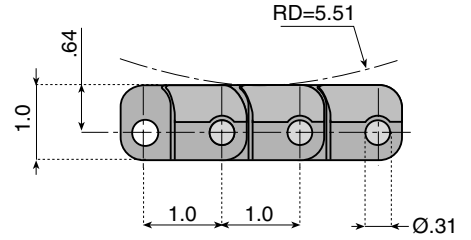
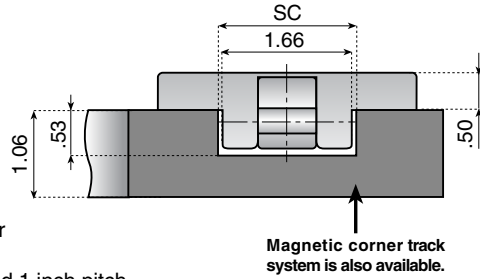
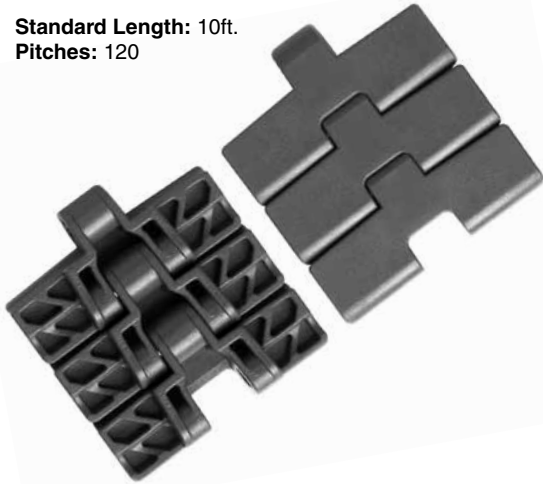

Use in combination with 2252 series belts



See page 146 for more information.

Material: "LFG Dark Grey" Low friction acetal with 304 stainless pins.

Chain Reference	Part Number	L (width)	R min.	SC Straight	SC Curved	Max Load (lbs.)	Weight (lbs. per ft.)
LFG2251FT-M-K330	11322	3.3	20	1.77	1.73	450	1.18
LFG2251FT-M-K450	11328	4.5	20	1.77	1.73	450	1.47

Material: "NGG Light Grey" Low friction material with 304 stainless pins.

Chain Reference	Part Number	L (width)	R min.	SC Straight	SC Curved	Max Load (lbs.)	Weight (lbs. per ft.)
NGG2251FT-M-K330	11322NGG	3.3	20	1.77	1.73	450	1.18
NGG2251FT-M-K450	11328NGG	4.5	20	1.77	1.73	450	1.47

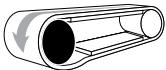

Drive Sprocket Options for 2251 M Chain-Belts



Machined Split

Shaft Sized Bore Dia.	Teeth or Equivalent	Part Number
.71*	16	121017
1	16	321018
1-1/4	16	321019
1-7/16	16	321020
1-1/2	16	-
.71*	18	121023
1	18	321024
1-1/4	18	321025
1-7/16	18	321026
1-1/2	18	321027
.71*	19	121029
1	19	321030
1-1/4	19	321031
1-7/16	19	321032
1-1/2	19	321033

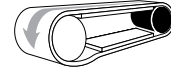

Idler Options for 2251 M Chain-Belts



Machined Split

Part Number
-
321065
321066
321067
321068
-
321070
321071
321072
321073
-
321075
321076
321077
321078

See all sprockets and idlers on pages 101-125

*Plain bore pilot hole. Not sized to a shaft.

Side Flexing Flat Top Chain-Belt

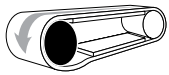

Drive Sprocket Options for 2251 M Chain-Belts

For delivery information, contact customer service.



Molded Single Key



Molded Double Key



Molded Square Shaft

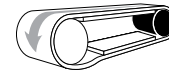

Idler Options for 2251 M Chain-Belts



Molded Split

Shaft Sized Bore Dia.	Teeth or Equivalent	Part Number	Part Number	Part Number	Part Number
1-1/2 x 1-1/2 sq.	16	-	-	123108S	-
1-1/4	16	123099S	123103S	-	123109S
1-7/16	16	123100S	123104S	-	123110S
1-1/2	16	123101S	123105S	-	123111S
1-3/4	16	123102S	123106S	-	123112S
1-1/2 x 1-1/2 sq.	18	-	-	123122S	-
1-1/4	18	123113S	123117S	-	123123S
1-7/16	18	123114S	123118S	-	123124S
1-1/2	18	123115S	123119S	-	123125S
1-3/4	18	123116S	123120S	-	123126S
1-1/2 x 1-1/2 sq.	19	-	-	123136S	-
1-1/4	19	123127S	123131S	-	123137S
1-7/16	19	123128S	123132S	-	123138S
1-1/2	19	123129S	123133S	-	123139S
1-3/4	19	123130S	123134S	-	123140S

See all sprockets and idlers on pages 101-125

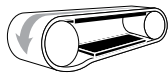

Track Options for 2251 TAB Chain-Belts / K330 Series

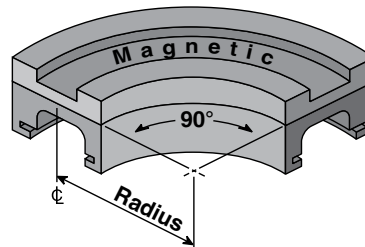

Number of Tracks	Total Width		Curve Angle					
	mm	inches	15°	30°	45°	60°	75°	90°
1	100	3.94	KMD.16.15.01.A	KMD.16.30.01.A	KMD.16.45.01.A	KMD.16.60.01.A	KMD.16.75.01.A	KMD.16.90.01.A
2	185	7.28	KMD.16.15.02.A	KMD.16.30.02.A	KMD.16.45.02.A	KMD.16.60.02.A	KMD.16.75.02.A	KMD.16.90.02.A
3	270	10.63	KMD.16.15.03.A	KMD.16.30.03.A	KMD.16.45.03.A	KMD.16.60.03.A	KMD.16.75.03.A	KMD.16.90.03.A
4	355	13.98	KMD.16.15.04.A	KMD.16.30.04.A	KMD.16.45.04.A	KMD.16.60.04.A	KMD.16.75.04.A	KMD.16.90.04.A

For additional number of tracks in a magnetic curve, see the chain track catalog section.

See all Magnetic Corner Tracks on pages 146-153

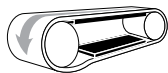

Track Options for 2251 TAB Chain-Belts / K450 Series

Number of Tracks	Total Width		Curve Angle					
	mm	inches	15°	30°	45°	60°	75°	90°
1	129	5.08	KMD.66.15.01.A	KMD.66.30.01.A	KMD.66.45.01.A	KMD.66.60.01.A	KMD.66.75.01.A	KMD.66.90.01.A
2	246	9.69	KMD.66.15.02.A	KMD.66.30.02.A	KMD.66.45.02.A	KMD.66.60.02.A	KMD.66.75.02.A	KMD.66.90.02.A
3	363	14.29	KMD.66.15.03.A	KMD.66.30.03.A	KMD.66.45.03.A	KMD.66.60.03.A	KMD.66.75.03.A	KMD.66.90.03.A
4	480	18.90	KMD.66.15.04.A	KMD.66.30.04.A	KMD.66.45.04.A	KMD.66.60.04.A	KMD.66.75.04.A	KMD.66.90.04.A



Sprockets Page 102
 Split Sprockets
 Heavy Duty & molded
 Idler Wheels

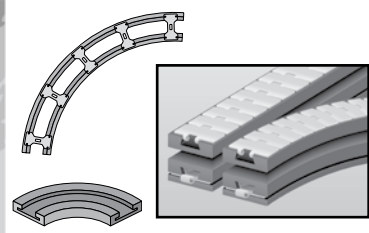

ValuTrac™ Page 130
 Bevel style modules
 Tab style modules
 Custom sizes and styles

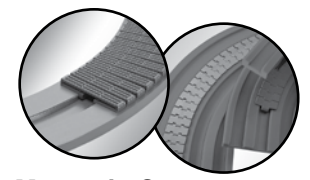

**Magnetic Corner
 Tracks Page 146**

S P R O C K E T S , W E A R S T R I P S & C O N V E Y O R C H A I N G U I D E S

Section 2

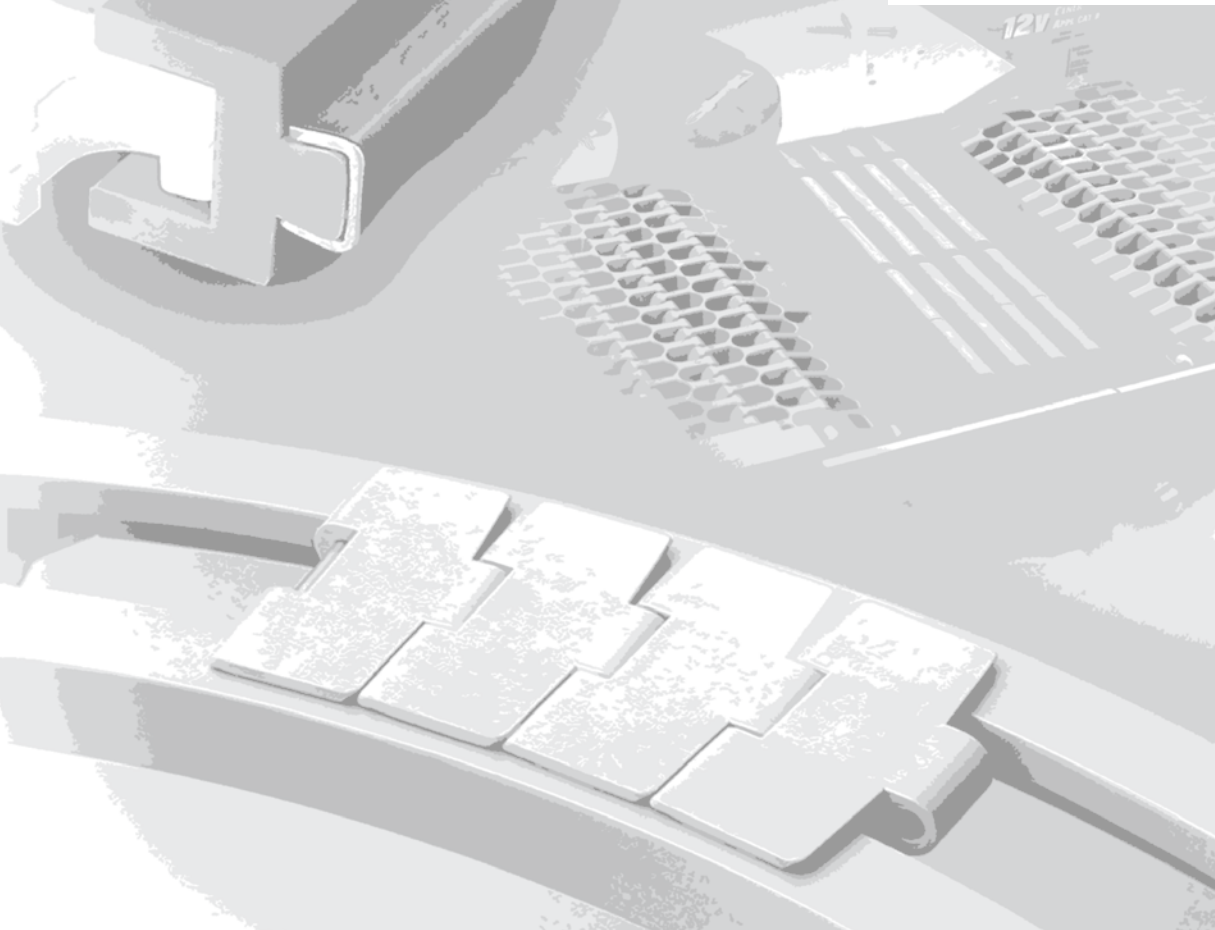

**DynaPlate &
 Modular Transfer
 Plates Page 156**

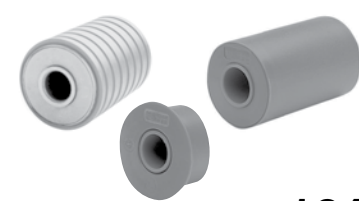

Return Rollers...Page 164

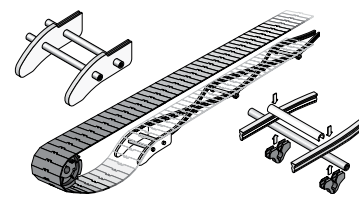

ValuFlex™ Page 169
 Serpentine Return System
 UHMW profiles Chain Return Shoes
 SnapLock Clips Spacers
 PinchLock Clips Cross Rods



Split Sprockets & Idlers

Sprockets for Chain Series:
812, 815, 815VG, 881M, 881MO

Special shape of the sprocket teeth compensates for natural chain lengthening after prolonged use!

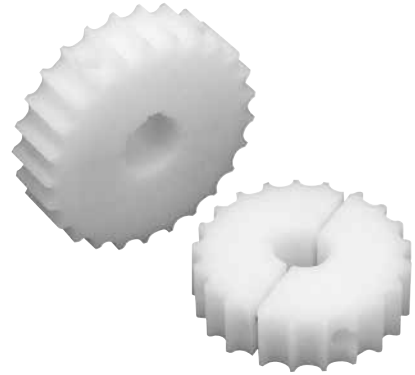

These sprockets have been machined from solid polyamide material, giving them a completely closed structure which is easier to clean and disinfect. The reinforced design of the sprocket ensures smooth running with reduced noise levels. Additional benefits include increased keyway strength, excellent chemical resistance, and long service life.

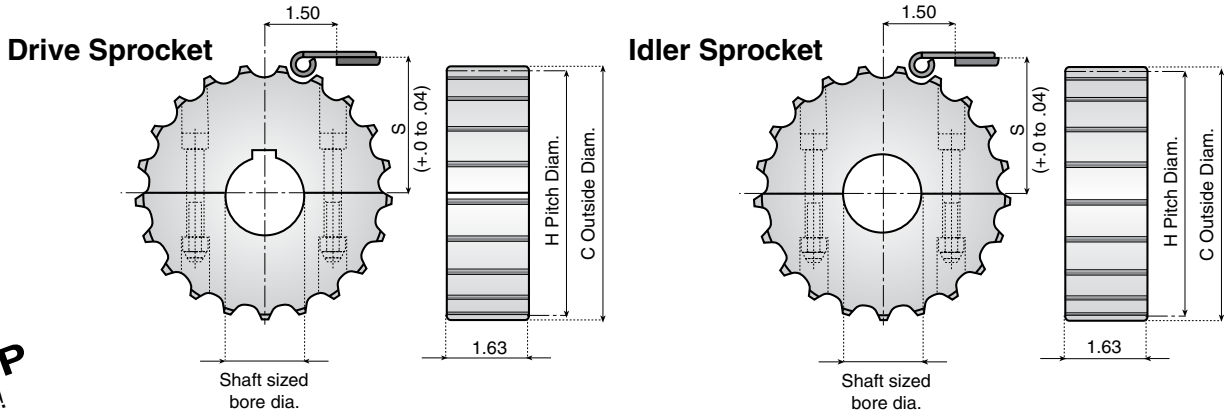

For HACCP Needs!

Material: Polyamide body, stainless steel connecting screws.

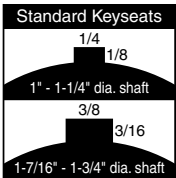

Positioning pins ensure accurate tooth alignment and aid assembly.

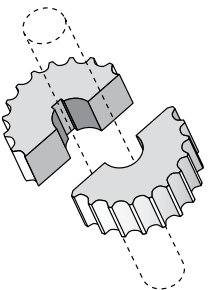

Save installation time with split sprockets and idler wheels.

Sprocket Part Number	Reference Code	Idler Part Number	Reference Code	Shaft Sized Bore Dia.	Number of Teeth	Outside Diameter C	Pitch Diameter H	Shaft Center to Wear Surface S (+0 to .04)
12905	815-19MP-.71	-	-	.71*	19	4.61	4.62	2.44
12529S	815-19MP-1	121239S	815-19MP-IDL-1	1	19	4.61	4.62	2.44
12530S	815-19MP-1.25	121240S	815-19MP-IDL-1.25	1-1/4	19	4.61	4.62	2.44
12538S	815-19MP-1.44	121241S	815-19MP-IDL-1.44	1-7/16	19	4.61	4.62	2.44
12539S	815-19MP-1.5	121242S	815-19MP-IDL-1.5	1-1/2	19	4.61	4.62	2.44
12906	815-21MP-.71	-	-	.71*	21	5.08	5.09	2.67
12540S	815-21MP-1	121243S	815-21MP-IDL-1	1	21	5.08	5.09	2.67
12541S	815-21MP-1.25	121244S	815-21MP-IDL-1.25	1-1/4	21	5.08	5.09	2.67
12542S	815-21MP-1.44	121245S	815-21MP-IDL-1.44	1-7/16	21	5.08	5.09	2.67
12543S	815-21MP-1.5	121246S	815-21MP-IDL-1.5	1-1/2	21	5.08	5.09	2.67
12907	815-23MP-.71	-	-	.71*	23	5.59	5.56	2.91
12544S	815-23MP-1	121247S	815-23MP-IDL-1	1	23	5.59	5.56	2.91
12545S	815-23MP-1.25	121248S	815-23MP-IDL-1.25	1-1/4	23	5.59	5.56	2.91
12546S	815-23MP-1.44	121249S	815-23MP-IDL-1.44	1-7/16	23	5.59	5.56	2.91
12547S	815-23MP-1.5	121250S	815-23MP-IDL-1.5	1-1/2	23	5.59	5.56	2.91
12908	815-25MP-.71	-	-	.71*	25	6.06	6.03	3.14
12548S	815-25MP-1	121251S	815-25MP-IDL-1	1	25	6.06	6.03	3.14
12549S	815-25MP-1.25	121252S	815-25MP-IDL-1.25	1-1/4	25	6.06	6.03	3.14
12550S	815-25MP-1.44	121253S	815-25MP-IDL-1.44	1-7/16	25	6.06	6.03	3.14
12551S	815-25MP-1.5	121254S	815-25MP-IDL-1.5	1-1/2	25	6.06	6.03	3.14
121199	815-27MP-.71	-	-	.71*	27	6.57	6.50	3.38
121200S	815-27MP-1	121255S	815-27MP-IDL-1	1	27	6.57	6.50	3.38
121201S	815-27MP-1.25	121256S	815-27MP-IDL-1.25	1-1/4	27	6.57	6.50	3.38
-	-	121257S	815-27MP-IDL-1.44	1-7/16	27	6.57	6.50	3.38
121203S	815-27MP-1.5	121258S	815-27MP-IDL-1.5	1-1/2	27	6.57	6.50	3.38

*Plain bore pilot hole. Not sized to a shaft.



Split Sprockets & Idlers

Sprockets for Chain Series:
812, 815, 815VG, 881M, 881MO



Sprockets, Wear
Strips, Chain Guides

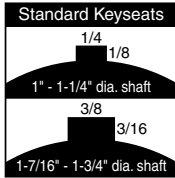
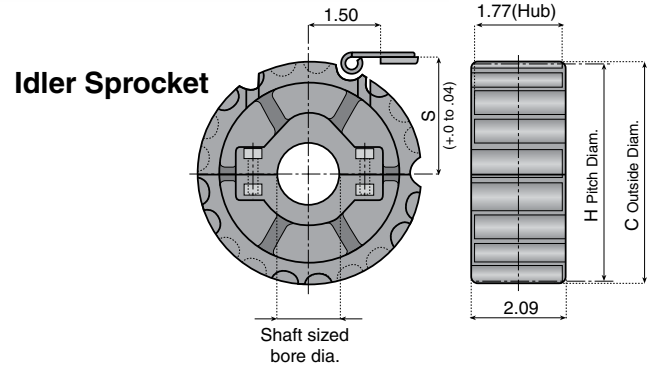
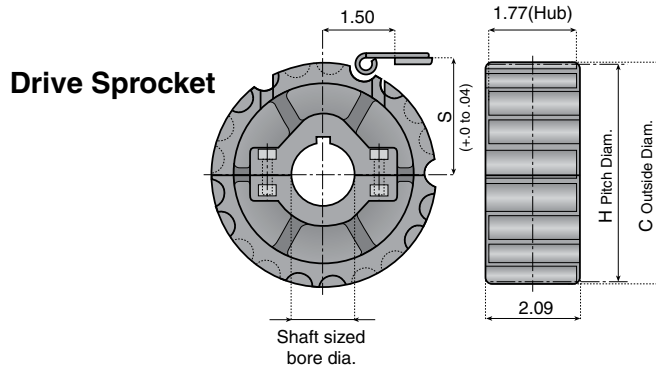

Material: Polyamide body with stainless steel connecting screws and nuts in nickel plated brass.

Sprocket Part Number	Reference Code	Idler Part Number	Reference Code	Shaft Sized Bore Dia.	Number of Teeth	Outside Diameter C	Pitch Diameter H	Shaft Center to Wear Surface S (+0 to .04)
32053	815-21P-1	321080	815-21P-IDL-1	1	21	5.08	5.09	2.67
32054	815-21P-1.25	321081	815-21P-IDL-1.25	1-1/4	21	5.08	5.09	2.67
32055	815-21P-1.44	321082	815-21P-IDL-1.44	1-7/16	21	5.08	5.09	2.67
32056	815-21P-1.5	321083	815-21P-IDL-1.5	1-1/2	21	5.08	5.09	2.67
32099	815-23P-1	321085	815-23P-IDL-1	1	23	5.59	5.56	2.91
32100	815-23P-1.25	321086	815-23P-IDL-1.25	1-1/4	23	5.59	5.56	2.91
32101	815-23P-1.44	321087	815-23P-IDL-1.44	1-7/16	23	5.59	5.56	2.91
32102	815-23P-1.5	321088	815-23P-IDL-1.5	1-1/2	23	5.59	5.56	2.91
32065	815-25P-1	321090	815-25P-IDL-1	1	25	6.06	6.03	3.14
32066	815-25P-1.25	321091	815-25P-IDL-1.25	1-1/4	25	6.06	6.03	3.14
32067	815-25P-1.44	321092	815-25P-IDL-1.44	1-7/16	25	6.06	6.03	3.14
32068	815-25P-1.5	321093	815-25P-IDL-1.5	1-1/2	25	6.06	6.03	3.14

Positioning pins ensure accurate tooth alignment and aid assembly.

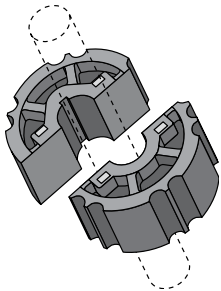

Save installation time with split sprockets and idler wheels.



Sprockets, Wear Strips, Chain Guides

Idler Wheels

Idlers for Chain Series:

812, 815, 815VG, 820, 828, 831, 831VG, LBP831, 879, 880, 879M, 880M, 879MVG, 881, 8810, 831VG, 881M, 881MO

Corrosion Resistant!



These idlers have an ultrasonic welded cover in reinforced polyamide that is available in black. The bushing is made of a low friction and low corrosion green resin. The reinforced design of the idler ensures smooth running with reduced noise levels.

Note: Not for use with Tab Chains.

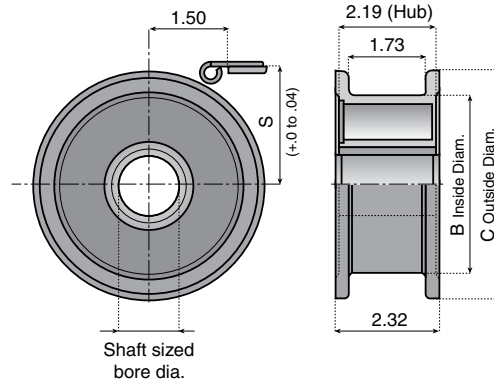

For HACCP Needs!

Material: Self lubricating polyamide body. Bushing is low friction resin.

Idler Part Number	Reference Code	Shaft Sized Bore Dia.	Equivalent Number of Teeth	Inside Diameter B	Outside Diameter C	Shaft Center to Wear Surface S (+0 to .04)
32866	815-21LF-IDL-1	1	21	4.07	5.10	2.70
32867	815-21LF-IDL-1.25	1-1/4	21	4.07	5.10	2.70
32868	815-21LF-IDL-1.44	1-7/16	21	4.07	5.10	2.70
32869	815-21LF-IDL-1.5	1-1/2	21	4.07	5.10	2.70
32874	815-23LF-IDL-1	1	23	4.07	5.63	2.94
32875	815-23LF-IDL-1.25	1-1/4	23	4.07	5.63	2.94
32876	815-23LF-IDL-1.44	1-7/16	23	4.07	5.63	2.94
32877	815-23LF-IDL-1.5	1-1/2	23	4.07	5.63	2.94
32870	815-25LF-IDL-1	1	25	4.80	6.08	3.17
32871	815-25LF-IDL-1.25	1-1/4	25	4.80	6.08	3.17
32872	815-25LF-IDL-1.44	1-7/16	25	4.80	6.08	3.17
32873	815-25LF-IDL-1.5	1-1/2	25	4.80	6.08	3.17



Split Idler Wheels

Idlers for Chain Series:
 812, 815, 815VG, 820, 828, 831,
 831VG, LBP831, 879, 880,
 879M, 880M, 879MVG, 881,
 881O, 831VG, 881M, 881MO

These reinforced idlers are molded out of self-lubricated black polyamide. Additional benefits include excellent high wear and chemical resistance, quickly replaceable, and recyclable.

Reinforced Version!



Sprockets, Wear Strips, Chain Guides

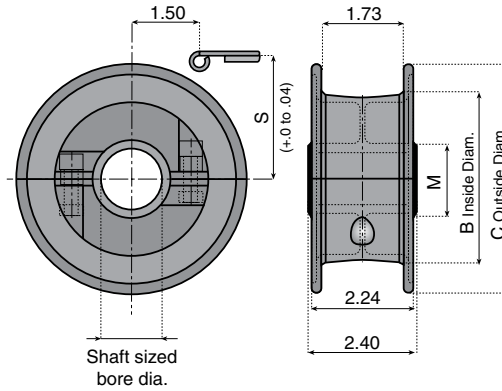

Positioning pins ensure accurate tooth alignment and aid assembly.

Material: Self lubricating polyamide body, stainless steel screws.

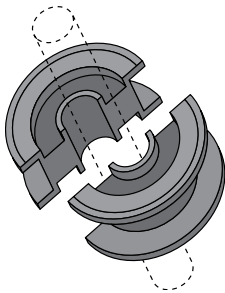

Idler Part Number	Reference Code	Shaft Sized Bore Dia.	Equivalent Number of Teeth	M	Inside Diameter B	Outside Diameter C	Shaft Center to Wear Surface S (+0 to .04)
32077B	815-21-IDL-1	1	21	1.38	3.82	5.11	2.70
32078B	815-21-IDL-1.25	1-1/4	21	1.57	3.82	5.11	2.70
32079B	815-21-IDL-1.44	1-7/16	21	1.77	3.82	5.11	2.70
32080B	815-21-IDL-1.5	1-1/2	21	1.97	3.82	5.11	2.70
32081B	815-25-IDL-1	1	25	1.38	4.02	6.09	3.17
32082B	815-25-IDL-1.25	1-1/4	25	1.57	4.02	6.09	3.17
32083B	815-25-IDL-1.44	1-7/16	25	1.77	4.02	6.09	3.17
32084B	815-25-IDL-1.5	1-1/2	25	1.97	4.02	6.09	3.17

Save installation time with split idler wheels.



Split Sprockets & Idlers

Sprockets for Chain Series:
881, 881O, 881VG, 881T, 881OT, 881TVG

Special shape of the sprocket teeth compensates for natural chain lengthening after prolonged use!

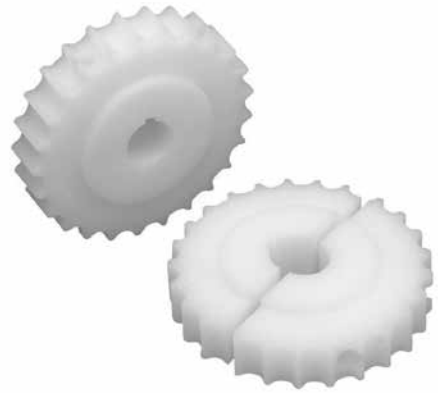

These sprockets have been machined from solid polyamide material, giving them a completely closed structure which is easier to clean and disinfect. The reinforced design of the sprocket ensures smooth running with reduced noise levels. Additional benefits include increased keyway strength, excellent chemical resistance, and long service life.

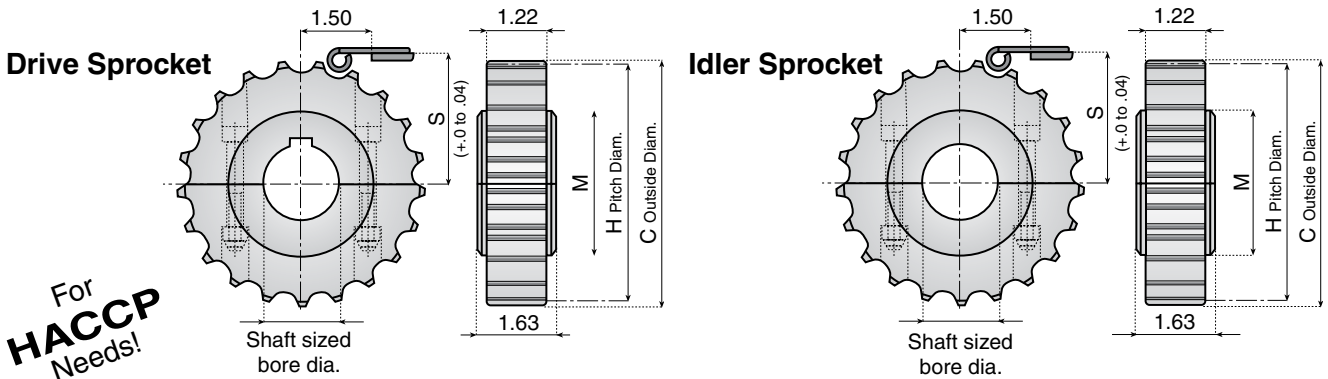

For HACCP Needs!

Material: Polyamide body, stainless steel connecting screws.

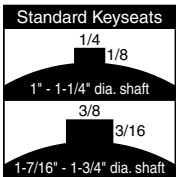

Positioning pins ensure accurate tooth alignment and aid assembly.

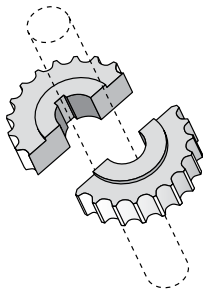

Save installation time with split sprockets and idler wheels.

Sprocket Part Number	Reference Code	Idler Part Number	Reference Code	Shaft Sized Bore Dia.	Number of Teeth	Outside Diameter C	Pitch Diameter H	M	Shaft Center to Wear Surface S (+0 to .04)
12966	881-19MP-.71	-	-	.71*	19	4.61	4.62	2.76	2.44
32469	881-19MP-1	321275	881-19MP-IDL-1	1	19	4.61	4.62	2.76	2.44
32470	881-19MP-1.25	-	-	1-1/4	19	4.61	4.62	2.76	2.44
32471	881-19MP-1.44	-	-	1-7/16	19	4.61	4.62	2.76	2.44
32472	881-19MP-1.5	321278	881-19MP-IDL-1.5	1-1/2	19	4.61	4.62	2.76	2.44
12967	881-21MP-.71	-	-	.71*	21	5.08	5.09	2.95	2.67
32473	881-21MP-1	321279	881-21MP-IDL-1	1	21	5.08	5.09	2.95	2.67
32474	881-21MP-1.25	321280	881-21MP-IDL-1.25	1-1/4	21	5.08	5.09	2.95	2.67
32475	881-21MP-1.44	-	-	1-7/16	21	5.08	5.09	2.95	2.67
32476	881-21MP-1.5	-	-	1-1/2	21	5.08	5.09	2.95	2.67
12968	881-23MP-.71	-	-	.71*	23	5.59	5.56	3.15	2.91
32477	881-23MP-1	321283	881-23MP-IDL-1	1	23	5.59	5.56	3.15	2.91
32478	881-23MP-1.25	321284	881-23MP-IDL-1.25	1-1/4	23	5.59	5.56	3.15	2.91
32479	881-23MP-1.44	321285	881-23MP-IDL-1.44	1-7/16	23	5.59	5.56	3.15	2.91
32480	881-23MP-1.5	321286	881-23MP-IDL-1.5	1-1/2	23	5.59	5.56	3.15	2.91
12969	881-25MP-.71	-	-	.71*	25	6.06	6.03	3.54	3.14
32481	881-25MP-1	-	-	1	25	6.06	6.03	3.54	3.14
32482	881-25MP-1.25	-	-	1-1/4	25	6.06	6.03	3.54	3.14
32483	881-25MP-1.44	321289	881-25MP-IDL-1.44	1-7/16	25	6.06	6.03	3.54	3.14
32484	881-25MP-1.5	321290	881-25MP-IDL-1.5	1-1/2	25	6.06	6.03	3.54	3.14
121217	881-27MP-.71	-	-	.71*	27	6.57	6.50	3.94	3.38
321218	881-27MP-1	-	-	1	27	6.57	6.50	3.94	3.38
321219	881-27MP-1.25	-	-	1-1/4	27	6.57	6.50	3.94	3.38
321220	881-27MP-1.44	-	-	1-7/16	27	6.57	6.50	3.94	3.38
321221	881-27MP-1.5	-	-	1-1/2	27	6.57	6.50	3.94	3.38

*Plain bore pilot hole. Not sized to a shaft.



Split Sprockets & Idlers

Sprockets for Chain Series:
881, 881O, 881VG, 881T, 8810T, 881TVG



Sprockets, Wear
Strips, Chain Guides

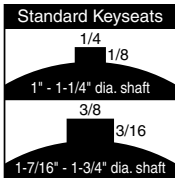
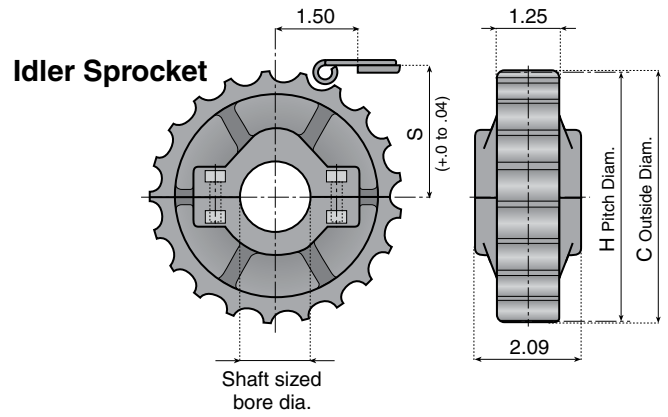
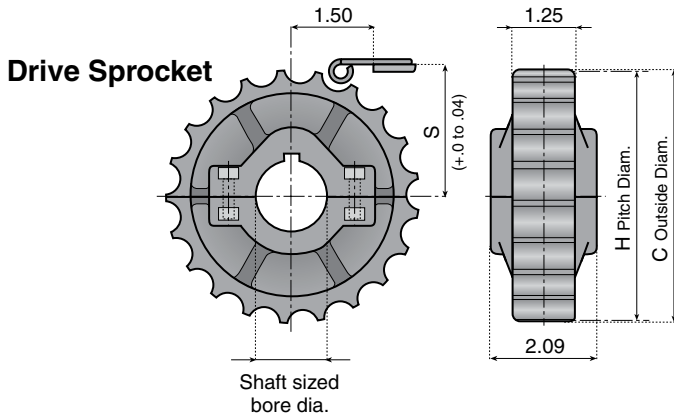

Material: Polyamide body with stainless steel connecting screws and nuts in nickel plated brass.

Sprocket Part Number	Reference Code	Idler Part Number	Reference Code	Shaft Sized Bore Dia.	Number of Teeth	Outside Diameter C	Pitch Diameter H	Shaft Center to Wear Surface S (+0 to .04)
32061	881-21P-1	321110	881-21P-IDL-1	1	21	5.08	5.09	2.67
32062	881-21P-1.25	-	-	1-1/4	21	5.08	5.09	2.67
32063	881-21P-1.44	-	-	1-7/16	21	5.08	5.09	2.67
32064	881-21P-1.5	-	-	1-1/2	21	5.08	5.09	2.67
32109	881-23P-1	-	-	1	23	5.59	5.56	2.91
32110	881-23P-1.25	-	-	1-1/4	23	5.59	5.56	2.91
32111	881-23P-1.44	321117	881-23P-IDL-1.44	1-7/16	23	5.59	5.56	2.91
32112	881-23P-1.5	321118	881-23P-IDL-1.5	1-1/2	23	5.59	5.56	2.91
32073	881-25P-1	321120	881-25P-IDL-1	1	25	6.06	6.03	3.14
32074	881-25P-1.25	321121	881-25P-IDL-1.25	1-1/4	25	6.06	6.03	3.14
32075	881-25P-1.44	-	-	1-7/16	25	6.06	6.03	3.14
32076	881-25P-1.5	-	-	1-1/2	25	6.06	6.03	3.14

Positioning pins ensure accurate tooth alignment and aid assembly.

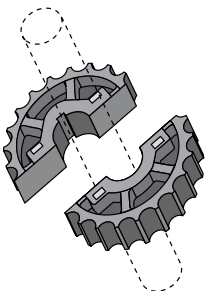

Save installation time with split sprockets and idler wheels.



Split Sprockets & Idlers

Sprockets for Chain Series: 820, 831, LBP831, 831VG

Special shape of the sprocket teeth compensates for natural chain lengthening after prolonged use!



These sprockets have been machined from solid polyamide material, giving them a completely closed structure which is easier to clean and disinfect. The reinforced design of the sprocket ensures smooth running with reduced noise levels. Additional benefits include increased keyway strength, excellent chemical resistance, and long service life.

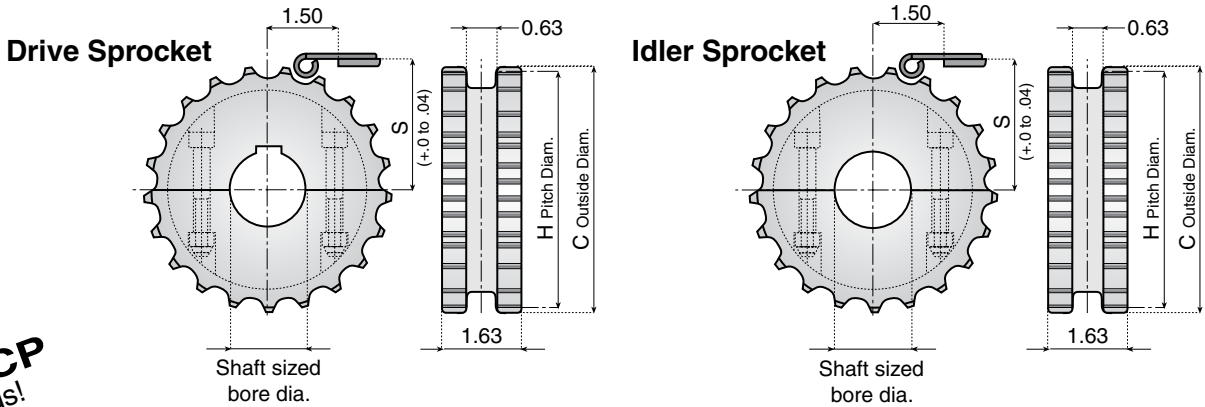

For HACCP Needs!

Material: Polyamide body, stainless steel connecting screws.

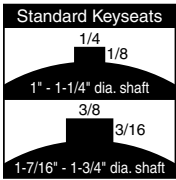

Positioning pins ensure accurate tooth alignment and aid assembly.

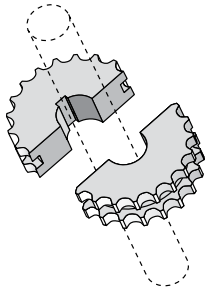

Save installation time with split sprockets and idler wheels.

Sprocket Part Number	Reference Code	Idler Part Number	Reference Code	Shaft Sized Bore Dia.	Number of Teeth	Outside Diameter C	Pitch Diameter H	Shaft Center to Wear Surface S (+0 to .04)
12961	820-19MP-.71	-	-	.71*	19	4.61	4.62	2.44
12924S	820-19MP-1	121147S	820-19MP-IDL-1	1	19	4.61	4.62	2.44
12925S	820-19MP-1.25	121148S	820-19MP-IDL-1.25	1-1/4	19	4.61	4.62	2.44
12926S	820-19MP-1.44	121149S	820-19MP-IDL-1.44	1-7/16	19	4.61	4.62	2.44
12927S	820-19MP-1.5	121150S	820-19MP-IDL-1.5	1-1/2	19	4.61	4.62	2.44
12962	820-21MP-.71	-	-	.71*	21	5.08	5.09	2.67
12928S	820-21MP-1	121151S	820-21MP-IDL-1	1	21	5.08	5.09	2.67
12929S	820-21MP-1.25	121152S	820-21MP-IDL-1.25	1-1/4	21	5.08	5.09	2.67
12930S	820-21MP-1.44	121153S	820-21MP-IDL-1.44	1-7/16	21	5.08	5.09	2.67
12931S	820-21MP-1.5	121154S	820-21MP-IDL-1.5	1-1/2	21	5.08	5.09	2.67
12963	820-23MP-.71	-	-	.71*	23	5.59	5.56	2.91
12932S	820-23MP-1	121155S	820-23MP-IDL-1	1	23	5.59	5.56	2.91
12933S	820-23MP-1.25	121156S	820-23MP-IDL-1.25	1-1/4	23	5.59	5.56	2.91
12934S	820-23MP-1.44	121157S	820-23MP-IDL-1.44	1-7/16	23	5.59	5.56	2.91
12964	820-25MP-.71	-	-	.71*	25	6.06	6.03	3.14
12936S	820-25MP-1	121159S	820-25MP-IDL-1	1	25	6.06	6.03	3.14
12937S	820-25MP-1.25	121160S	820-25MP-IDL-1.25	1-1/4	25	6.06	6.03	3.14
12938S	820-25MP-1.44	121161S	820-25MP-IDL-1.44	1-7/16	25	6.06	6.03	3.14
12939S	820-25MP-1.5	121162S	820-25MP-IDL-1.5	1-1/2	25	6.06	6.03	3.14
121125	820-27MP-.71	-	-	.71*	27	6.57	6.50	3.38
121126S	820-27MP-1	121163S	820-27MP-IDL-1	1	27	6.57	6.50	3.38
121127S	820-27MP-1.25	121164S	820-27MP-IDL-1.25	1-1/4	27	6.57	6.50	3.38
121128S	820-27MP-1.44	121165S	820-27MP-IDL-1.44	1-7/16	27	6.57	6.50	3.38
121129S	820-27MP-1.5	121166S	820-27MP-IDL-1.5	1-1/2	27	6.57	6.50	3.38

*Plain bore pilot hole. Not sized to a shaft.



Split Sprockets & Idlers

Sprockets for Chain Series:
820, 831, LBP831, 831VG



Sprockets, Wear
Strips, Chain Guides

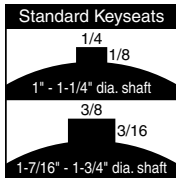
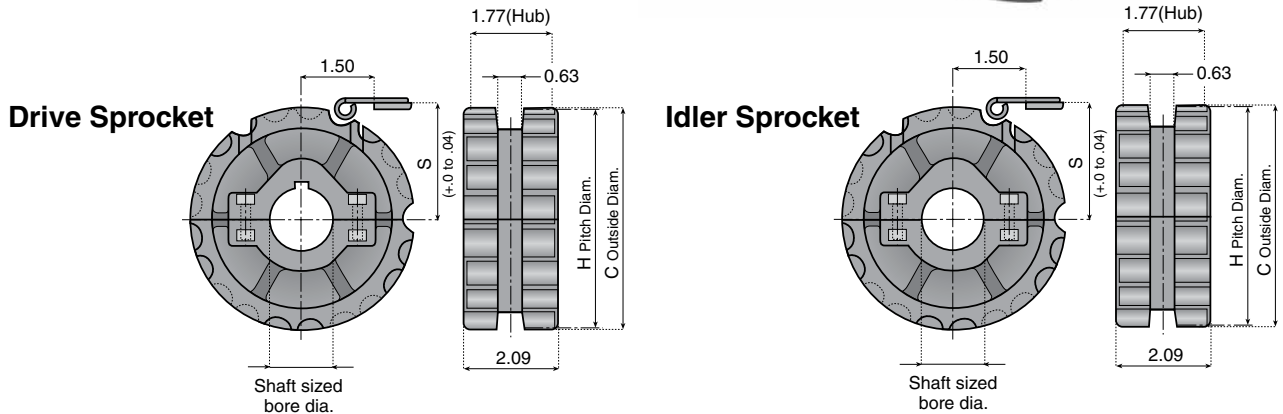

Material: Polyamide body with stainless steel connecting screws and nuts in nickel plated brass.

Sprocket Part Number	Reference Code	Idler Part Number	Reference Code	Shaft Sized Bore Dia.	Number of Teeth	Outside Diameter C	Pitch Diameter H	Shaft Center to Wear Surface S (+0 to .04)
32057	820-21P-1	321095	820-21P-IDL-1	1	21	5.08	5.09	2.67
32058	820-21P-1.25	321096	820-21P-IDL-1.25	1-1/4	21	5.08	5.09	2.67
32059	820-21P-1.44	321097	820-21P-IDL-1.44	1-7/16	21	5.08	5.09	2.67
32060	820-21P-1.5	321098	820-21P-IDL-1.5	1-1/2	21	5.08	5.09	2.67
32104	820-23P-1	321100	820-23P-IDL-1	1	23	5.59	5.56	2.91
32105	820-23P-1.25	321101	820-23P-IDL-1.25	1-1/4	23	5.59	5.56	2.91
32106	820-23P-1.44	321102	820-23P-IDL-1.44	1-7/16	23	5.59	5.56	2.91
32107	820-23P-1.5	321103	820-23P-IDL-1.5	1-1/2	23	5.59	5.56	2.91
32069	820-25P-1	321105	820-25P-IDL-1	1	25	6.06	6.03	3.14
32070	820-25P-1.25	321106	820-25P-IDL-1.25	1-1/4	25	6.06	6.03	3.14
32071	820-25P-1.44	321107	820-25P-IDL-1.44	1-7/16	25	6.06	6.03	3.14
32072	820-25P-1.5	321108	820-25P-IDL-1.5	1-1/2	25	6.06	6.03	3.14

Positioning pins ensure accurate tooth alignment and aid assembly.

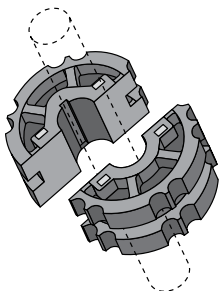

Save installation time with split sprockets and idler wheels.



Split Sprockets & Idlers

Sprockets for Chain Series: 821, LBP821, 821VG

These sprockets have been machined from solid polyamide material, giving them a completely closed structure which is easier to clean and disinfect. The reinforced design of the sprocket ensures smooth running with reduced noise levels. Additional benefits include increased keyway strength, excellent chemical resistance, and long service life.

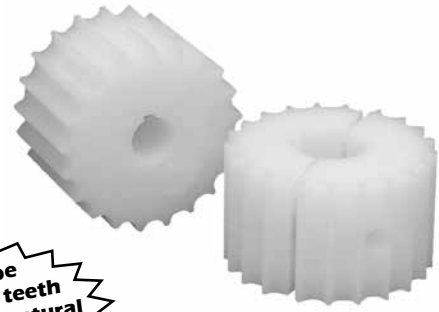

Special shape of the sprocket teeth compensates for natural chain lengthening after prolonged use!

Drive Sprocket

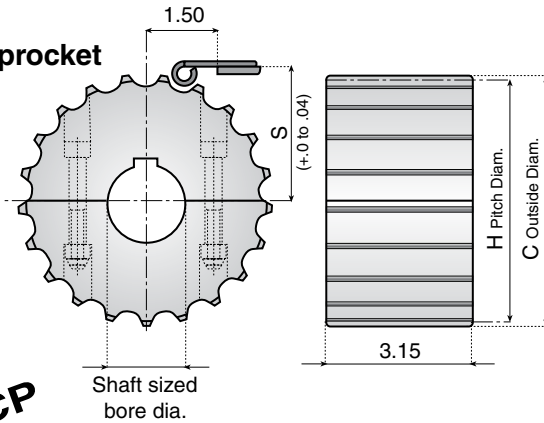

Idler Sprocket

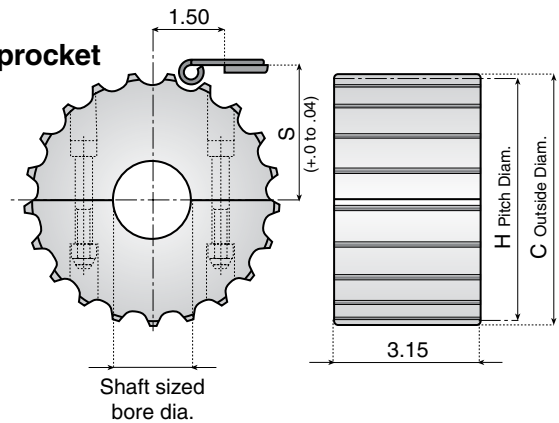

For HACCP Needs!

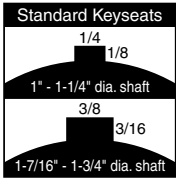

Material: Polyamide body, stainless steel connecting screws.

Sprocket Part Number	Reference Code	Idler Part Number	Reference Code	Shaft Sized Bore Dia.	Number of Teeth	Outside Diameter C	Pitch Diameter H	Shaft Center to Wear Surface S (+0 to .04)
12901	821-21MP-.71	-	-	.71*	21	5.08	5.09	2.67
12284S	821-21MP-1	121329S	821-21MP-IDL-1	1	21	5.08	5.09	2.67
12285S	821-21MP-1.25	121330S	821-21MP-IDL-1.25	1-1/4	21	5.08	5.09	2.67
12286S	821-21MP-1.44	121331S	821-21MP-IDL-1.44	1-7/16	21	5.08	5.09	2.67
12287S	821-21MP-1.5	121332S	821-21MP-IDL-1.5	1-1/2	21	5.08	5.09	2.67
12902	821-23MP-.71	-	-	.71*	23	5.59	5.56	2.91
12288S	821-23MP-1	121333S	821-23MP-IDL-1	1	23	5.59	5.56	2.91
12289S	821-23MP-1.25	121334S	821-23MP-IDL-1.25	1-1/4	23	5.59	5.56	2.91
12290S	821-23MP-1.44	121335S	821-23MP-IDL-1.44	1-7/16	23	5.59	5.56	2.91
12291S	821-23MP-1.5	121336S	821-23MP-IDL-1.5	1-1/2	23	5.59	5.56	2.91
12903	821-25MP-.71	-	-	.71*	25	6.06	6.03	3.14
12292S	821-25MP-1	121337S	821-25MP-IDL-1	1	25	6.06	6.03	3.14
12293S	821-25MP-1.25	121338S	821-25MP-IDL-1.25	1-1/4	25	6.06	6.03	3.14
12294S	821-25MP-1.44	121339S	821-25MP-IDL-1.44	1-7/16	25	6.06	6.03	3.14
12295S	821-25MP-1.5	121340S	821-25MP-IDL-1.5	1-1/2	25	6.06	6.03	3.14
121307	821-27MP-.71	-	-	.71*	27	6.57	6.50	3.38
121308S	821-27MP-1	121341S	821-27MP-IDL-1	1	27	6.57	6.50	3.38
121309S	821-27MP-1.25	121342S	821-27MP-IDL-1.25	1-1/4	27	6.57	6.50	3.38
121310S	821-27MP-1.44	121343S	821-27MP-IDL-1.44	1-7/16	27	6.57	6.50	3.38
121311S	821-27MP-1.5	121344S	821-27MP-IDL-1.5	1-1/2	27	6.57	6.50	3.38

*Plain bore pilot hole. Not sized to a shaft.

Positioning pins ensure accurate tooth alignment and aid assembly.

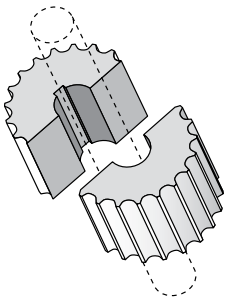

Save installation time with split sprockets and idler wheels.



Sprockets & Idlers

Sprockets for Chain Series:
821, LBP821, 821VG



Sprockets, Wear
Strips, Chain Guides

Drive Sprocket

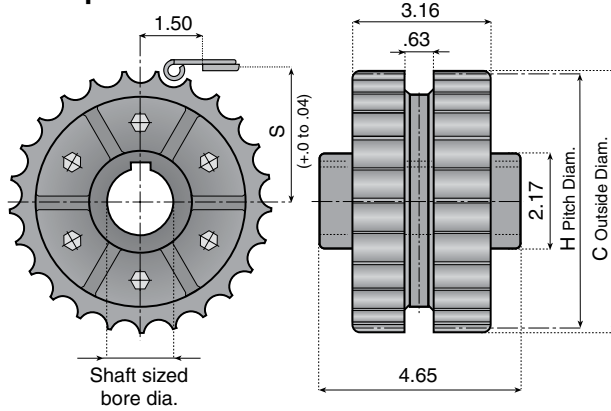

Idler Sprocket

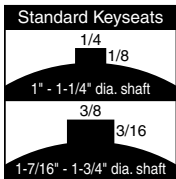
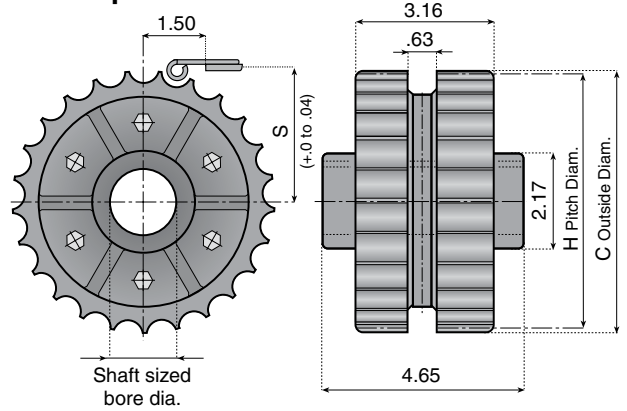

Material: Polyamide body, stainless steel connecting screws.

Sprocket Part Number	Idler Part Number	Shaft Sized Bore Dia.	Number of Teeth	Outside Diameter C	Pitch Diameter H	Shaft Center to Wear Surface S (+0 to .04)
32085	32089	1	25	6.06	6.03	3.14
32086	32090	1-1/4	25	6.06	6.03	3.14
32086S	32090S	1-7/16	25	6.06	6.03	3.14
32087	32092	1-1/2	25	6.06	6.03	3.14



Split Sprockets & Idlers

Sprockets for Chain Series:
828, 878TAB, 878TAB VG, 879, 879TAB, 879M,
879TAB VG, 880, 880TAB, 880M, 878TGS, LBP878T

These sprockets have been machined from solid polyamide material, giving them a completely closed structure which is easier to clean and disinfect. The reinforced design of the sprocket ensures smooth running with reduced noise levels. Additional benefits include increased keyway strength, excellent chemical resistance, and long service life.

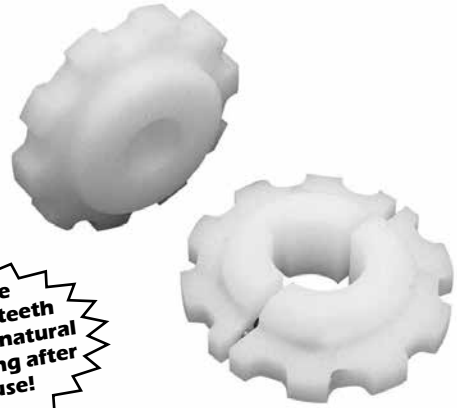

Special shape of the sprocket teeth compensates for natural chain lengthening after prolonged use!

Drive Sprocket

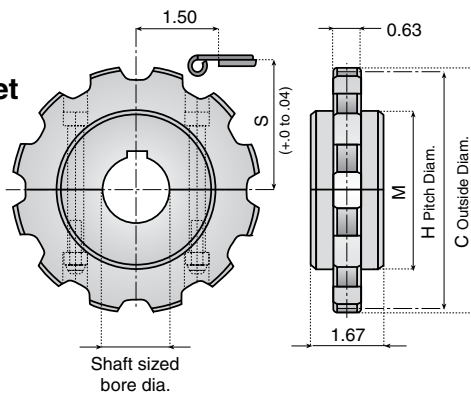

Idler Sprocket

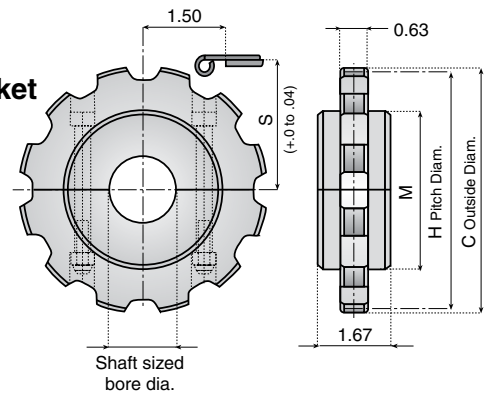

For HACCP Needs!

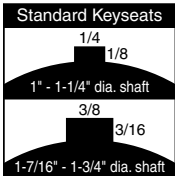

Positioning pins ensure accurate tooth alignment and aid assembly.

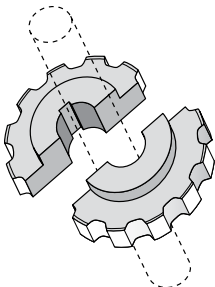

Save installation time with split sprockets and idler wheels.

Material: Polyamide body, stainless steel connecting screws.

Sprocket Part Number	Reference Code	Idler Part Number	Reference Code	Shaft Sized Bore Dia.	Number of Teeth	Outside Diameter C	Pitch Diameter H	M	Shaft Center to Wear Surface S (+0 to .04)
12910	880-9MP-.71	-	-	.71*	9	4.33	4.39	2.95	2.33
12382S	880-9MP-1	121752S	880-9MP-IDL-1	1	9	4.33	4.39	2.95	2.33
12383S	880-9MP-1.25	121753S	880-9MP-IDL-1.25	1-1/4	9	4.33	4.39	2.95	2.33
12384S	880-9MP-1.44	121754S	880-9MP-IDL-1.44	1-7/16	9	4.33	4.39	2.95	2.33
12385S	880-9MP-1.5	121755S	880-9MP-IDL-1.5	1-1/2	9	4.33	4.39	2.95	2.33
12911	880-10MP-.71	-	-	.71*	10	4.80	4.85	3.35	2.45
12386S	880-10MP-1	121756S	880-10MP-IDL-1	1	10	4.80	4.85	3.35	2.45
12387S	880-10MP-1.25	121757S	880-10MP-IDL-1.25	1-1/4	10	4.80	4.85	3.35	2.45
12388S	880-10MP-1.44	121758S	880-10MP-IDL-1.44	1-7/16	10	4.80	4.85	3.35	2.45
12389S	880-10MP-1.5	121759S	880-10MP-IDL-1.5	1-1/2	10	4.80	4.85	3.35	2.45
12912	880-11MP-.71	-	-	.71*	11	5.31	5.32	3.54	2.80
12390S	880-11MP-1	121760S	880-11MP-IDL-1	1	11	5.31	5.32	3.54	2.80
12391S	880-11MP-1.25	121761S	880-11MP-IDL-1.25	1-1/4	11	5.31	5.32	3.54	2.80
12392S	880-11MP-1.44	121762S	880-11MP-IDL-1.44	1-7/16	11	5.31	5.32	3.54	2.80
12393S	880-11MP-1.5	121763S	880-11MP-IDL-1.5	1-1/2	11	5.31	5.32	3.54	2.80
12913	880-12MP-.71	-	-	.71*	12	5.80	5.80	3.74	3.04
12394S	880-12MP-1	121764S	880-12MP-IDL-1	1	12	5.80	5.80	3.74	3.04
12395S	880-12MP-1.25	121765S	880-12MP-IDL-1.25	1-1/4	12	5.80	5.80	3.74	3.04
12396S	880-12MP-1.44	121766S	880-12MP-IDL-1.44	1-7/16	12	5.80	5.80	3.74	3.04
12397S	880-12MP-1.5	121767S	880-12MP-IDL-1.5	1-1/2	12	5.80	5.80	3.74	3.04

*Plain bore pilot hole. Not sized to a shaft.



Split Sprockets & Idlers

Sprockets for Chain Series:
 828, 878TAB, 878TAB VG, 879, 879TAB,
 879M, 879TAB VG, 880, 880TAB,
 880M, 878TGS, LBP878T



Sprockets, Wear
 Strips, Chain Guides

Drive Sprocket

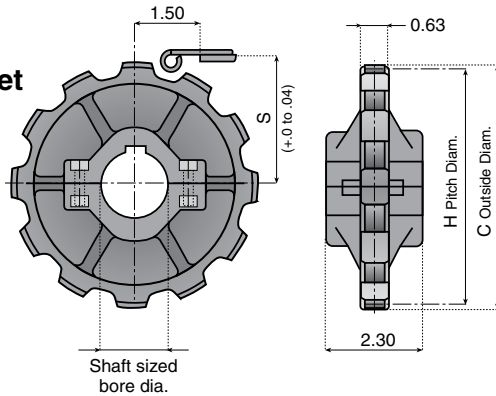

Idler Sprocket

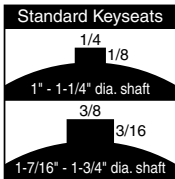
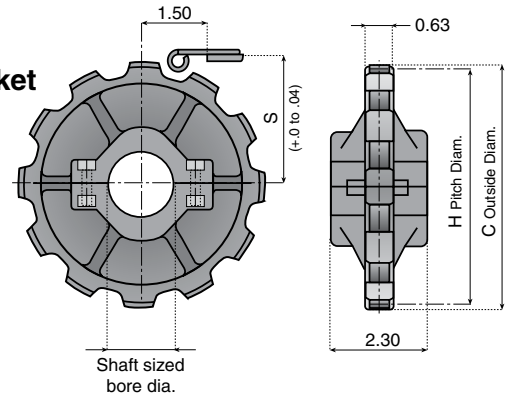

Material: Polyamide body with stainless steel connecting screws and nuts in nickel plated brass.

Sprocket Part Number	Reference Code	Idler Part Number	Reference Code	Shaft Sized Bore Dia.	Number of Teeth	Outside Diameter C	Pitch Diameter H	Shaft Center to Wear Surface S (+0 to .04)
321001	880-10P-1	321005	880-10P-IDL-1	1	10	4.80	4.85	2.57
321002	880-10P-1.25	321006	880-10P-IDL-1.25	1-1/4	10	4.80	4.85	2.57
321003	880-10P-1.44	321007	880-10P-IDL-1.44	1-7/16	10	4.80	4.85	2.57
321004	880-10P-1.5	321008	880-10P-IDL-1.5	1-1/2	10	4.80	4.85	2.57
32400	880-12P-1	32403	880-12P-IDL-1	1	12	5.80	5.80	3.04
32711	880-12P-1.25	32404	880-12P-IDL-1.25	1-1/4	12	5.80	5.80	3.04
32401	880-12P-1.44	32405	880-12P-IDL-1.44	1-7/16	12	5.80	5.80	3.04
32402	880-12P-1.5	32406	880-12P-IDL-1.5	1-1/2	12	5.80	5.80	3.04

Positioning pins ensure accurate tooth alignment and aid assembly.

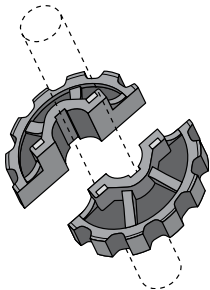

Save installation time with split sprockets and idler wheels.



Split Sprockets & Idlers

Sprockets for Chain Series:
882, 882M, 882T, 882TVG, LBP882T

These sprockets have been machined from solid polyamide material, giving them a completely closed structure which is easier to clean and disinfect. The reinforced design of the sprocket ensures smooth running with reduced noise levels. Additional benefits include increased keyway strength, excellent chemical resistance, and long service life.

Special shape of the sprocket teeth compensates for natural chain lengthening after prolonged use!

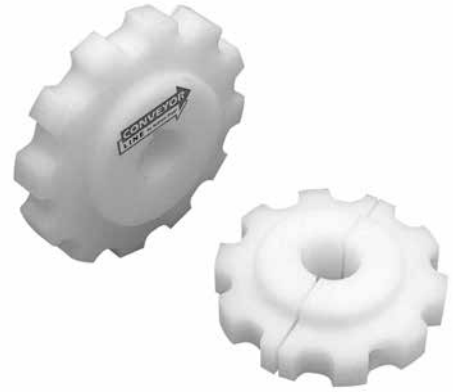

Sprockets, Wear Strips, Chain Guides

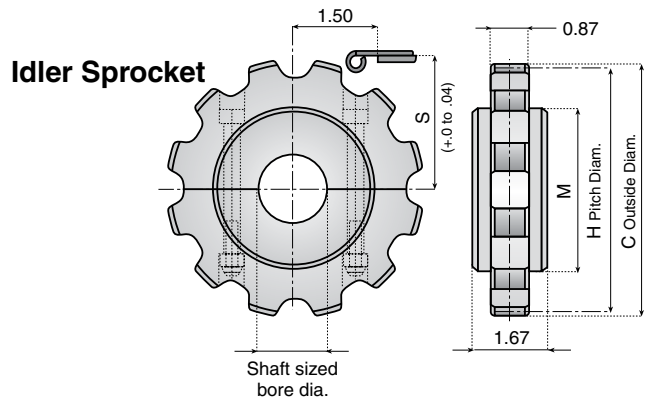
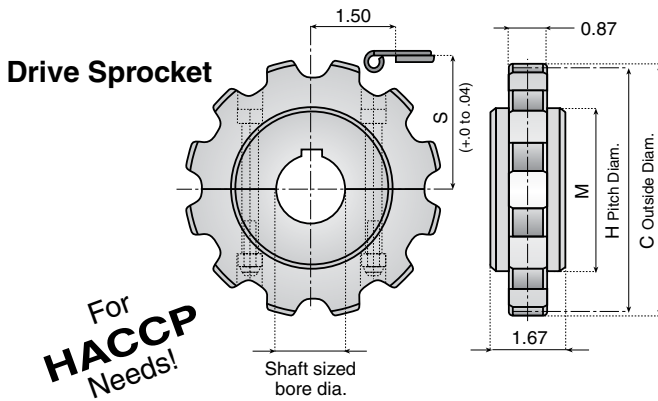

For HACCP Needs!

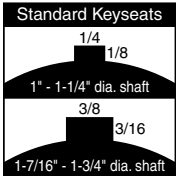

Material: Polyamide body, stainless steel connecting screws.

Sprocket Part Number	Reference Code	Idler Part Number	Reference Code	Shaft Sized Bore Dia.	Number of Teeth	Outside Diameter C	Pitch Diameter H	M	Shaft Center to Wear Surface S (+0 to .04)
12914	882-9MP-.71	-	-	.71*	9	4.41	4.39	2.36	2.38
12346S	882-9MP-1	121768S	882-9MP-IDL-1	1	9	4.41	4.39	2.36	2.38
12347S	882-9MP-1.25	121769S	882-9MP-IDL-1.25	1-1/4	9	4.41	4.39	2.36	2.38
12347SK	882-9MP-1.44	121769SK	882-9MP-IDL-1.44	1-7/16	9	4.41	4.39	2.36	2.38
12348S	882-9MP-1.5	121770S	882-9MP-IDL-1.5	1-1/2	9	4.41	4.39	2.36	2.38
12915	882-10MP-.71	-	-	.71*	10	4.92	4.85	2.95	2.61
12349S	882-10MP-1	121771S	882-10MP-IDL-1	1	10	4.92	4.85	2.95	2.61
12350S	882-10MP-1.25	121772S	882-10MP-IDL-1.25	1-1/4	10	4.92	4.85	2.95	2.61
12350SK	882-10MP-1.44	121772SK	882-10MP-IDL-1.44	1-7/16	10	4.92	4.85	2.95	2.61
12351S	882-10MP-1.5	121773S	882-10MP-IDL-1.5	1-1/2	10	4.92	4.85	2.95	2.61
12916	882-11MP-.71	-	-	.71*	11	5.39	5.32	3.35	2.85
12352S	882-11MP-1	121774S	882-11MP-IDL-1	1	11	5.39	5.32	3.35	2.85
12353S	882-11MP-1.25	121775S	882-11MP-IDL-1.25	1-1/4	11	5.39	5.32	3.35	2.85
12353SK	882-11MP-1.44	121775SK	882-11MP-IDL-1.44	1-7/16	11	5.39	5.32	3.35	2.85
12354S	882-11MP-1.5	121776S	882-11MP-IDL-1.5	1-1/2	11	5.39	5.32	3.35	2.85
12917	882-12MP-.71	-	-	.71*	12	5.87	5.80	3.54	3.09
12355S	882-12MP-1	121777S	882-12MP-IDL-1	1	12	5.87	5.80	3.54	3.09
12356S	882-12MP-1.25	121778S	882-12MP-IDL-1.25	1-1/4	12	5.87	5.80	3.54	3.09
12356SK	882-12MP-1.44	121778SK	882-12MP-IDL-1.44	1-7/16	12	5.87	5.80	3.54	3.09
12357S	882-12MP-1.5	121779S	882-12MP-IDL-1.5	1-1/2	12	5.87	5.80	3.54	3.09

*Plain bore pilot hole. Not sized to a shaft.

Positioning pins ensure accurate tooth alignment and aid assembly.

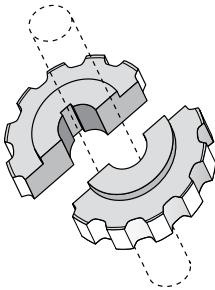

Save installation time with split sprockets and idler wheels.



Split Sprockets & Idlers

Sprockets for Chain Series:
882, 882M, 882T, 882TVG, LBP882T



Sprockets, Wear
Strips, Chain Guides

Drive Sprocket

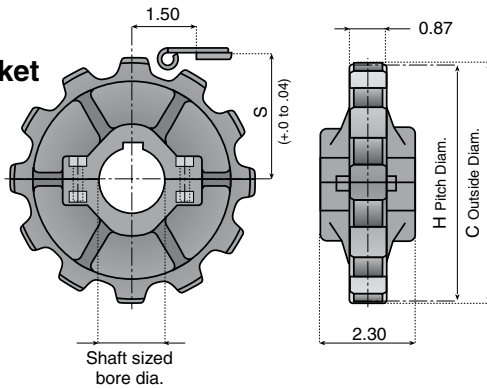

Idler Sprocket

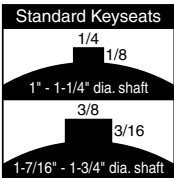
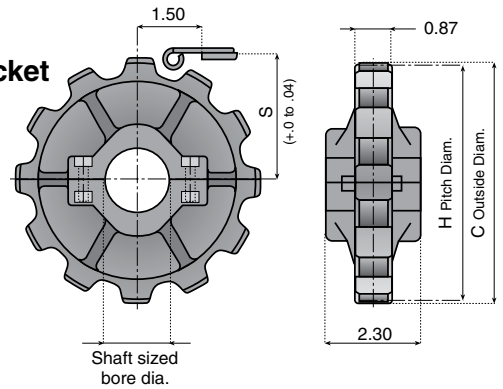

Positioning pins ensure accurate tooth alignment and aid assembly.

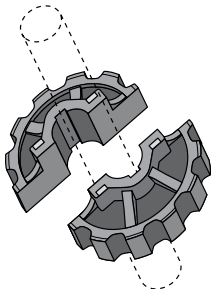

Save installation time with split sprockets and idler wheels.

Material: Polyamide body with stainless steel connecting screws and nuts in nickel plated brass.

Sprocket Part Number	Reference Code	Idler Part Number	Reference Code	Shaft Sized Bore Dia.	Number of Teeth	Outside Diameter C	Pitch Diameter H	Shaft Center to Wear Surface S (+0 to .04)
321009	882-10P-1	321013	882-10P-IDL-1	1	10	4.92	4.85	2.57
321010	882-10P-1.25	321014	882-10P-IDL-1.25	1-1/4	10	4.92	4.85	2.57
321011	882-10P-1.44	321015	882-10P-IDL-1.44	1-7/16	10	4.92	4.85	2.57
321012	882-10P-1.5	321016	882-10P-IDL-1.5	1-1/2	10	4.92	4.85	2.57
32114	882-12P-1	32119	882-12P-IDL-1	1	12	5.87	5.80	3.09
32115	882-12P-1.25	32120	882-12P-IDL-1.25	1-1/4	12	5.87	5.80	3.09
32116	882-12P-1.44	32121	882-12P-IDL-1.44	1-7/16	12	5.87	5.80	3.09
32117	882-12P-1.5	32122	882-12P-IDL-1.5	1-1/2	12	5.87	5.80	3.09



Single Piece Sprockets & Idlers

Sprockets for Belt Series: 2121 H FT, LPB2120

These sprockets have been machined from solid polyamide material, giving them a completely closed structure which is easier to clean and disinfect. The reinforced design of the sprocket ensures smooth running with reduced noise levels. Additional benefits include increased keyway strength, excellent chemical resistance, and long service life.

Note:

- These sprockets can be used for belt widths up to 26 inches and temperature differences of maximum 86°F.
- For wider belts or bigger temperature differences, sprockets with square bores or round bore with two keyways have to be used.

To order single keyway sprockets capable of floating freely on the shaft (i.e. shaft sized bore $+0.01 / +.02$), just add the letter "P" (=plus) to the existing part number. For example, code **125500SVP**.



Special shape of the sprocket teeth compensates for natural chain lengthening after prolonged use!

Drive Sprocket

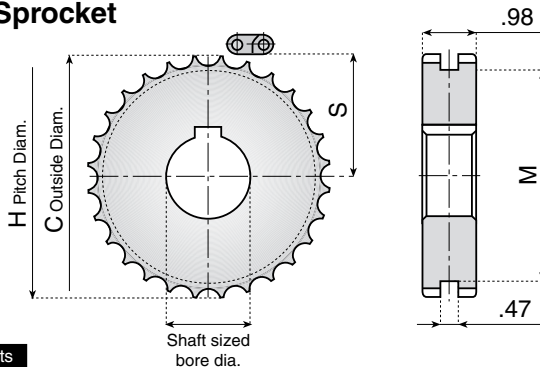

Idler Sprocket

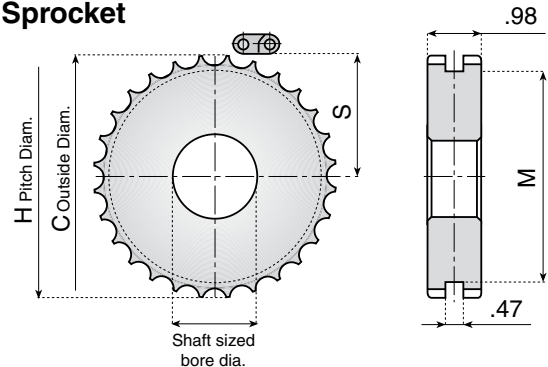

Standard Keyseats

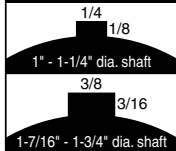

Material: Polyamide body.

Sprocket Part Number	Idler Part Number	Shaft Sized Bore Dia.	Number of Teeth	Outside Diameter C	Pitch Diameter H	M	Shaft Center to Wear Surface S (+0 to .04)
125500GV	-	.71*	16	2.57	2.56	2.17	1.11
125500VS	125500RIVS	1	16	2.57	2.56	2.17	1.11
125501VS	125501RIVS	1-1/4	16	2.57	2.56	2.17	1.11
125502GV	-	.71*	20	3.20	3.20	2.80	1.43
125502VS	125502RIVS	1	20	3.20	3.20	2.80	1.43
125503VS	125503RIVS	1-1/4	20	3.20	3.20	2.80	1.43
125504VS	125504RIVS	1-7/16	20	3.20	3.20	2.80	1.43
125505VS	125505RIVS	1-1/2	20	3.20	3.20	2.80	1.43
125506GV	-	.71*	24	3.83	3.83	3.43	1.74
125506VS	125506RIVS	1	24	3.83	3.83	3.43	1.74
125507VS	125507RIVS	1-1/4	24	3.83	3.83	3.43	1.74
125508VS	125508RIVS	1-7/16	24	3.83	3.83	3.43	1.74
125509VS	125509RIVS	1-1/2	24	3.83	3.83	3.43	1.74
125510GV	-	.71*	28	4.46	4.47	4.06	2.06
125510VS	125510RIVS	1	28	4.46	4.47	4.06	2.06
125511VS	125511RIVS	1-1/4	28	4.46	4.47	4.06	2.06
125512VS	125512RIVS	1-7/16	28	4.46	4.47	4.06	2.06
125513VS	125513RIVS	1-1/2	28	4.46	4.47	4.06	2.06

*Plain bore pilot hole. Not sized to a shaft.



Split Sprockets & Idlers

Sprockets for Belt Series: 2121 H FT, LPB2120

These sprockets have been machined from solid polyamide material, giving them a completely closed structure which is easier to clean and disinfect. The reinforced design of the sprocket ensures smooth running with reduced noise levels. Additional benefits include increased keyway strength, excellent chemical resistance, and long service life.

Note:

- These sprockets can be used for belt widths up to 26 inches and temperature differences of maximum 86°F.
- For wider belts or bigger temperature differences, sprockets with square bores or round bore with two keyways have to be used.

To order single keyway sprockets capable of floating freely on the shaft (i.e. shaft sized bore +.01 /+.02), just add the letter "P"(=plus) to the existing part number. For example, code **125600SVP**.



Sprockets, Wear Strips, Chain Guides

Special shape of the sprocket teeth compensates for natural chain lengthening after prolonged use!

Drive Sprocket

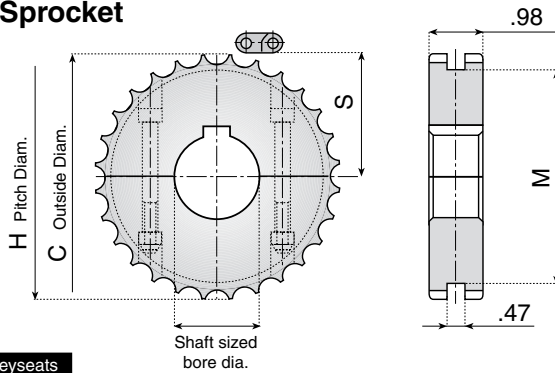

Idler Sprocket

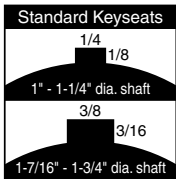
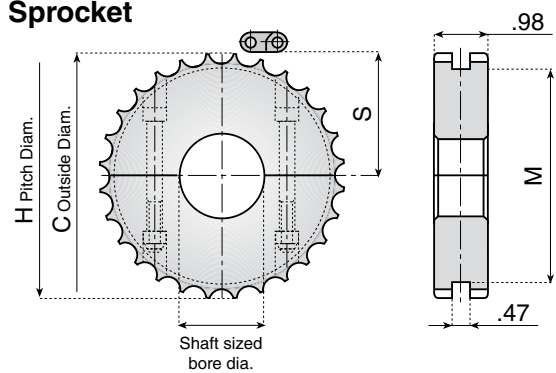

Material: Polyamide body, stainless steel connecting screws.

Sprocket Part Number	Idler Part Number	Shaft Sized Bore Dia.	Number of Teeth	Outside Diameter C	Pitch Diameter H	M	Shaft Center to Wear Surface S (+0 to .04)
125600GV	-	.71*	28	4.46	4.47	4.06	2.06
125600VS	125600RVS	1	28	4.46	4.47	4.06	2.06
125601VS	125601RVS	1-1/4	28	4.46	4.47	4.06	2.06
125602VS	125602RVS	1-7/16	28	4.46	4.47	4.06	2.06
125603VS	125603RVS	1-1/2	28	4.46	4.47	4.06	2.06

*Plain bore pilot hole. Not sized to a shaft.

Positioning pins ensure accurate tooth alignment and aid assembly.

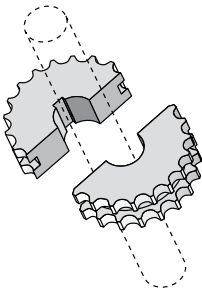

Save installation time with split sprockets and idler wheels.



Split Sprockets & Idlers

Sprockets for Belt Series: 2121 H FT, LPB2120

Sprocket features include excellent wear and chemical resistance, reduced noise levels, and a reinforced design. The completely closed structure is easier to clean and disinfect, plus the design of the sprocket ensures smooth running and a long service life. These sprockets float freely and can be used on the drive shaft and on the idler shaft.

Note:

- Single keyway sprockets can be used for belt widths up to 26 inches and temperature differences of maximum 86°F.
- For wider belts or bigger temperature differences, sprockets with square bores or round bore with two keyways have to be used.

To order single keyway sprockets capable of floating freely on the shaft (i.e. shaft sized bore +.01/+.02), just add the letter "P" (=plus) to the existing part number. For example, code **123099SP**.

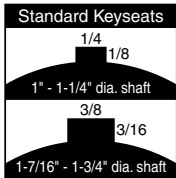
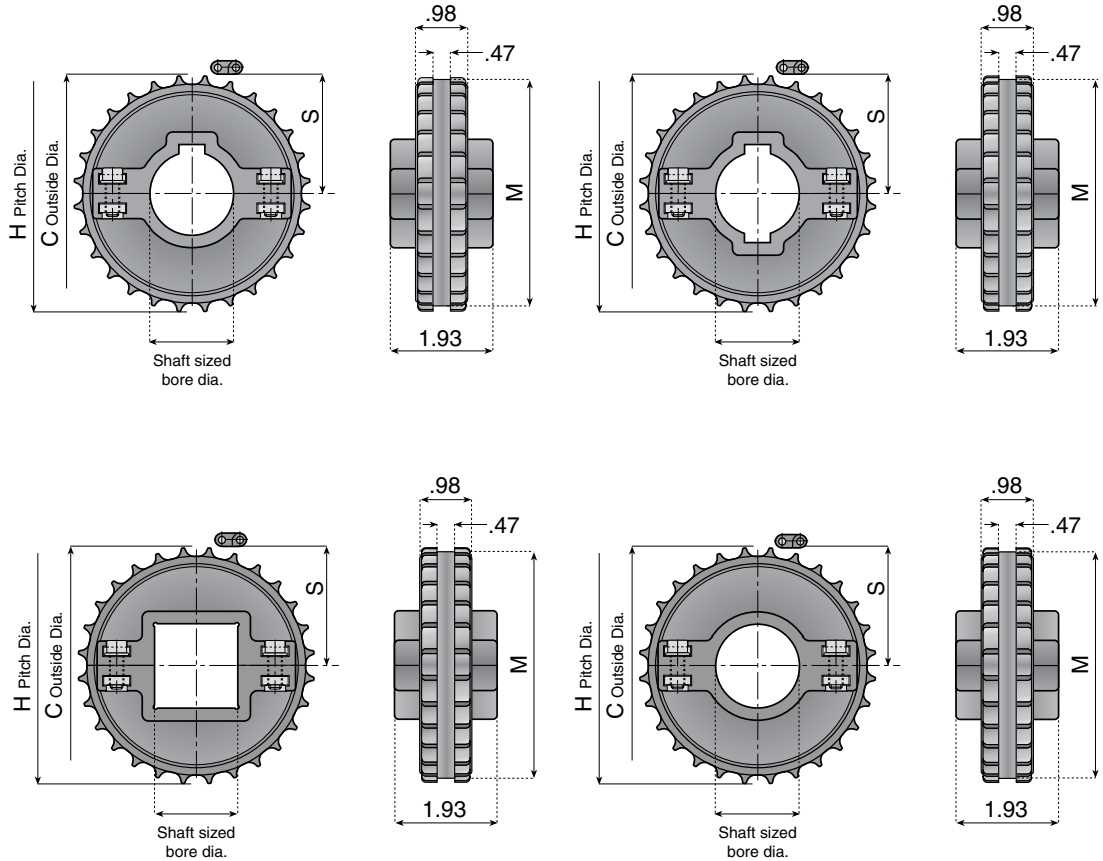

Material: Polyamide body with stainless steel connecting screws and nuts in nickel plated brass.

Single Keyway Sprocket Part Number	Double Keyway Sprocket Part Number	Square Bore Sprocket Part Number	Idler Part Number	Shaft Sized Bore Dia.	Number of Teeth	Outside Diameter C	Pitch Diameter H	M	Shaft Center to Wear Surface S (+0 to .04)
123190VS	123193VS	-	123197VS	1-1/4	24	3.84	3.83	3.43	1.74
123191VS	123194VS	-	123198VS	1-7/16	24	3.84	3.83	3.43	1.74
123192VS	123195VS	-	123199VS	1-1/2	24	3.84	3.83	3.43	1.74
-	-	123009VS	-						
123000VS	123004VS	-	123010VS	1-1/4	28	4.47	4.47	4.06	2.06
123001VS	123005VS	-	123011VS	1-7/16	28	4.47	4.47	4.06	2.06
-	-	-	123012VS	1-1/2	28	4.47	4.47	4.06	2.06
123003VS	123007VS	-	123013VS	1-3/4	28	4.47	4.47	4.06	2.06



Split Sprockets & Idlers

Sprockets for Multiflex Chain

These sprockets have been machined from solid polyamide material, giving them a completely closed structure which is easier to clean and disinfect. The reinforced design of the sprocket ensures smooth running with reduced noise levels. Additional benefits include increased keyway strength, excellent chemical resistance, and long service life.

Special shape of the sprocket teeth compensates for natural chain lengthening after prolonged use!

Sprockets, Wear Strips, Chain Guides

Drive Sprocket

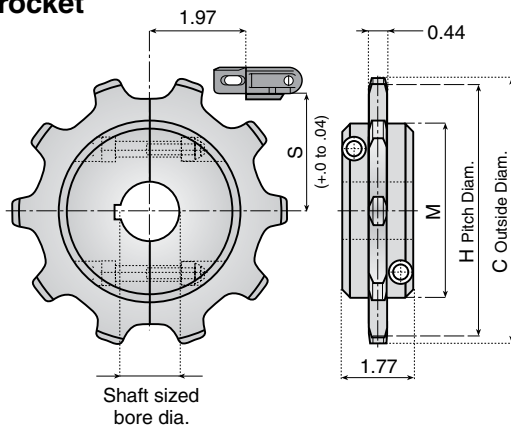

For HACCP Needs!

Idler Sprocket

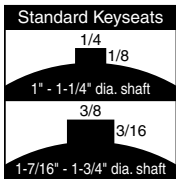
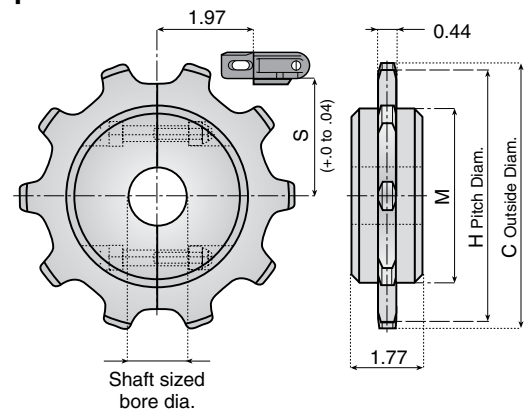

Positioning pins ensure accurate tooth alignment and aid assembly.

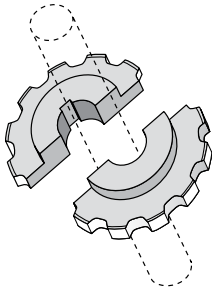

Save installation time with split sprockets and idler wheels.

Material: Polyamide body, stainless steel connecting screws.

Sprocket Part Number	Reference Code	Idler Part Number	Reference Code	Shaft Sized Bore Dia.	Number of Teeth	Outside Diameter C	Pitch Diameter H	Shaft Center to Wear Surface S (+0 to .04)	M	2.09
12730	1700-8MP-.71	-	-	.71*	8	5.37	5.07	3.15	2.09	
32731	1700-8MP-1	32736	1700-8MP-IDL-1	1	8	5.37	5.07	3.15	2.09	
32732	1700-8MP-1.25	32737	1700-8MP-IDL-1.25	1-1/4	8	5.37	5.07	3.15	2.09	
32733	1700-8MP-1.44	32738	1700-8MP-IDL-1.44	1-7/16	8	5.37	5.07	3.15	2.09	
32734	1700-8MP-1.5	32739	1700-8MP-IDL-1.5	1-1/2	8	5.37	5.07	3.15	2.09	
12745	1700-10MP-.71	-	-	.71*	10	6.50	6.37	4.33	2.72	
32746	1700-10MP-1	32741	1700-10MP-IDL-1	1	10	6.50	6.37	4.33	2.72	
32747	1700-10MP-1.25	32742	1700-10MP-IDL-1.25	1-1/4	10	6.50	6.37	4.33	2.72	
32748	1700-10MP-1.44	32743	1700-10MP-IDL-1.44	1-7/16	10	6.50	6.37	4.33	2.72	
32749	1700-10MP-1.5	32744	1700-10MP-IDL-1.5	1-1/2	10	6.50	6.37	4.33	2.72	
12750	1700-13MP-.71	-	-	.71*	13	8.46	8.22	5.91	3.68	
32751	1700-13MP-1	32756	1700-13MP-IDL-1	1	13	8.46	8.22	5.91	3.68	
32752	1700-13MP-1.25	32757	1700-13MP-IDL-1.25	1-1/4	13	8.46	8.22	5.91	3.68	
32753	1700-13MP-1.44	32758	1700-13MP-IDL-1.44	1-7/16	13	8.46	8.22	5.91	3.68	
32754	1700-13MP-1.5	32759	1700-13MP-IDL-1.5	1-1/2	13	8.46	8.22	5.91	3.68	

*Plain bore pilot hole. Not sized to a shaft.



Sprockets, Wear Strips, Chain Guides

Split Sprockets & Idlers

Sprockets for Chain-Belts Series: 2250 TAB FT, 2251 TAB FT

These sprockets have been machined from solid polyamide material, giving them a completely closed structure which is easier to clean and disinfect. The reinforced design of the sprocket ensures smooth running with reduced noise levels. Additional benefits include increased keyway strength, excellent chemical resistance, and long service life.

To order single keyway sprockets capable of floating freely on the shaft (i.e. shaft sized bore $+.01 / +.02$), just add the letter "P" (=plus) to the existing part number. For example, code **125502SP**.

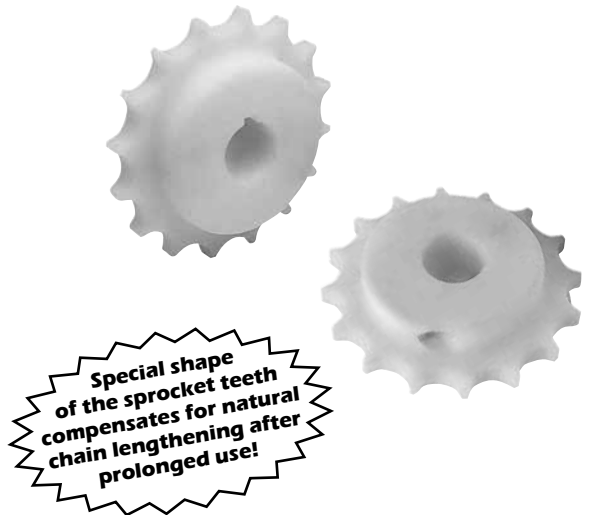

Drive Sprocket

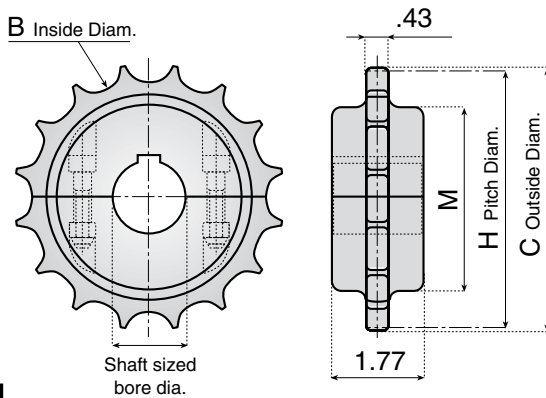

Idler Sprocket

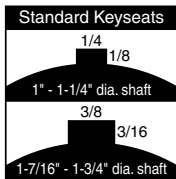
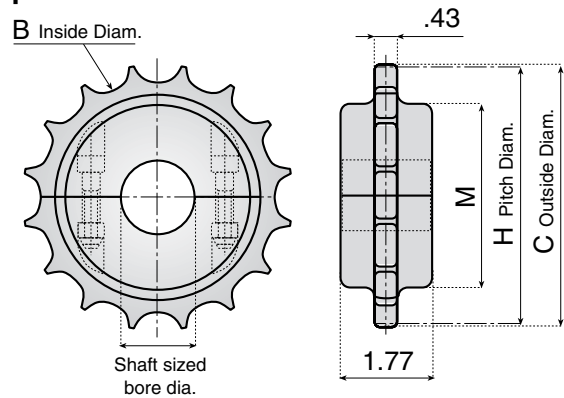

Positioning pins ensure accurate tooth alignment and aid assembly.

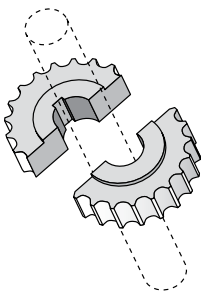

Save installation time with split sprockets and idler wheels.

Material: Polyamide body, stainless steel connecting screws.

Sprocket Part Number	Idler Part Number	Shaft Sized Bore Dia.	Number of Teeth	Outside Diameter C	Pitch Diameter H	Inside Diameter B	M
121017	-	.71*	16	5.15	5.07	4.45	3.54
321018	321065	1	16	5.15	5.07	4.45	3.54
321019	321066	1-1/4	16	5.15	5.07	4.45	3.54
321020	321067	1-7/16	16	5.15	5.07	4.45	3.54
121023	-	.71*	18	5.78	5.70	5.07	4.13
321024	321070	1	18	5.78	5.70	5.07	4.13
321025	321071	1-1/4	18	5.78	5.70	5.07	4.13
321026	321072	1-7/16	18	5.78	5.70	5.07	4.13
321027	321073	1-1/2	18	5.78	5.70	5.07	4.13
121029	-	.71*	19	6.15	6.07	5.44	4.33
321030	321075	1	19	6.15	6.07	5.44	4.33
321031	321076	1-1/4	19	6.15	6.07	5.44	4.33
321032	321077	1-7/16	19	6.15	6.07	5.44	4.33
321033	321078	1-1/2	19	6.15	6.07	5.44	4.33

*Plain bore pilot hole. Not sized to a shaft.



Split Sprockets & Idlers

Sprockets for Chain-Belts Series: 2250 TAB FT, 2251 TAB FT, 2260

Sprocket features include excellent wear and chemical resistance, reduced noise levels, and a reinforced design. The completely closed structure is easier to clean and disinfect, plus the design of the sprocket ensures smooth running and a long service life. These sprockets float freely and can be used on the drive shaft and on the idler shaft.

Note:

- Single keyway sprockets can be used for belt widths up to 26 inches and temperature differences of maximum 86°F.
- For wider belts or bigger temperature differences, sprockets with square bores or round bore with two keyways have to be used.

To order single keyway sprockets capable of floating freely on the shaft (i.e. shaft sized bore +.01 /+.02), just add the letter "P" (=plus) to the existing part number. For example, code **123099SP**.

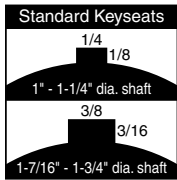

Sprockets, Wear Strips, Chain Guides

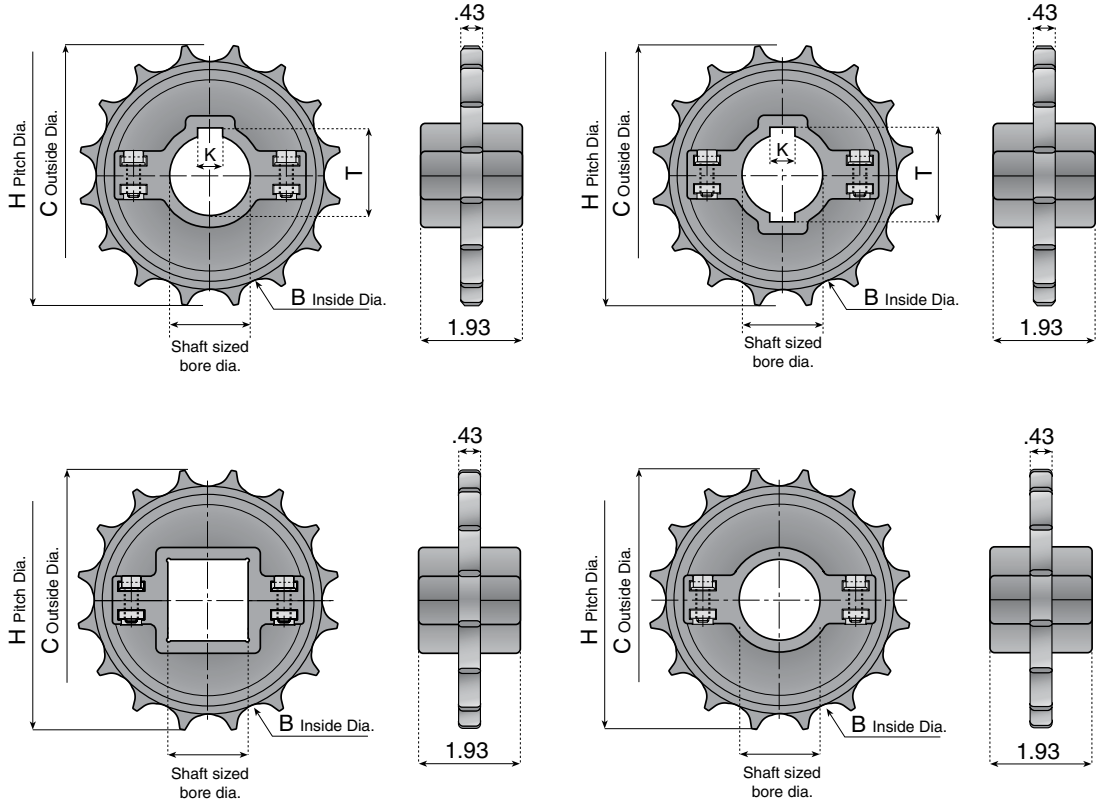

Material: Polyamide body with stainless steel connecting screws and nuts in nickel plated brass.

Single Keyway Sprocket Part Number	Double Keyway Sprocket Part Number	Square Bore Sprocket Part Number	Idler Part Number	Shaft Sized Bore Dia.	Number of Teeth	Inside Diameter B	Outside Diameter C	Pitch Diameter H	Shaft Center to Wear Surface S (+0 to .04)
-	-	123108S	-	1-1/2 x 1-1/2 sq.	16	4.45	5.15	5.08	2.67
123099S	123103S	-	123109S	1-1/4	16	4.45	5.15	5.08	2.67
123100S	123104S	-	123110S	1-7/16	16	4.45	5.15	5.08	2.67
123101S	123105S	-	123111S	1-1/2	16	4.45	5.15	5.08	2.67
123102S	123106S	-	123112S	1-3/4	16	4.45	5.15	5.08	2.67
-	-	123122S	-	1-1/2 x 1-1/2 sq.	18	5.07	5.78	5.70	2.98
123113S	123117S	-	123123S	1-1/4	18	5.07	5.78	5.70	2.98
123114S	123118S	-	123124S	1-7/16	18	5.07	5.78	5.70	2.98
123115S	123119S	-	123125S	1-1/2	18	5.07	5.78	5.70	2.98
123116S	123120S	-	123126S	1-3/4	18	5.07	5.78	5.70	2.98
-	-	123136S	-	1-1/2 x 1-1/2 sq.	19	5.45	6.15	6.08	3.17
123127S	123131S	-	123137S	1-1/4	19	5.45	6.15	6.08	3.17
123128S	123132S	-	123138S	1-7/16	19	5.45	6.15	6.08	3.17
123129S	123133S	-	123139S	1-1/2	19	5.45	6.15	6.08	3.17
123130S	123134S	-	123140S	1-3/4	19	5.45	6.15	6.08	3.17



Split Sprockets & Idlers

Sprockets for Belt Series: 2252 FT, 2252 PT, LBP 2251

These sprockets have been machined from solid polyamide material, giving them a completely closed structure which is easier to clean and disinfect. The reinforced design of the sprocket ensures smooth running with reduced noise levels. Additional benefits include increased keyway strength, excellent chemical resistance, and long service life.

Note:

- These sprockets can be used for belt widths up to 26 inches and temperature differences of maximum 86°F.
- For wider belts or bigger temperature differences, sprockets with square bores or round bore with two keyways have to be used.

To order single keyway sprockets capable of floating freely on the shaft (i.e. shaft sized bore +.01 /+.02), just add the letter "P" (=plus) to the existing part number. For example, code **125250SP**.



Special shape of the sprocket teeth compensates for natural chain lengthening after prolonged use!

Drive Sprocket

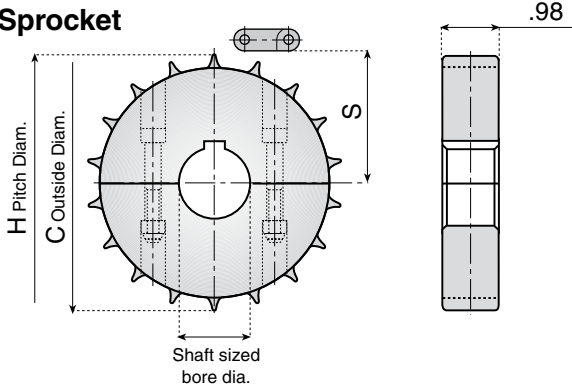

Idler Sprocket

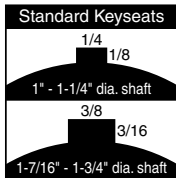
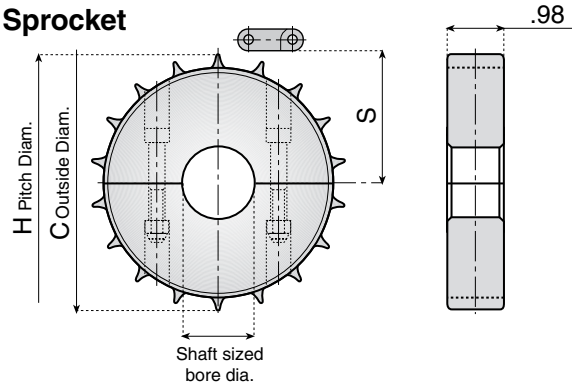

Positioning pins ensure accurate tooth alignment and aid assembly.

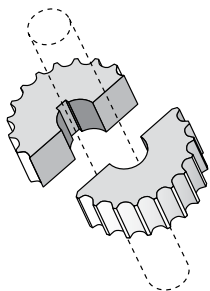

Save installation time with split sprockets and idler

Material: Polyamide body, stainless steel connecting screws.

Sprocket Part Number	Idler Part Number	Shaft Sized Bore Dia.	Number of Teeth	Outside Diameter C	Pitch Diameter H	Shaft Center to Wear Surface S (+0 to .04)
125250GF	-	.71*	16	5.12	5.13	2.31
125250S	125250RS	1	16	5.12	5.13	2.31
125251S	125251RS	1-1/4	16	5.12	5.13	2.31
125252S	125252RS	1-7/16	16	5.12	5.13	2.31
125253S	125253RS	1-1/2	16	5.12	5.13	2.31
125254GF	-	.71*	18	5.75	5.76	2.63
125254S	125254RS	1	18	5.75	5.76	2.63
125255S	125255RS	1-1/4	18	5.75	5.76	2.63
125256S	125256RS	1-7/16	18	5.75	5.76	2.63
125257S	125257RS	1-1/2	18	5.75	5.76	2.63
125258GF	-	.71*	20	6.38	6.39	2.94
125258S	125258RS	1	20	6.38	6.39	2.94
125259S	125259RS	1-1/4	20	6.38	6.39	2.94
125260S	125260RS	1-7/16	20	6.38	6.39	2.94
125261S	125261RS	1-1/2	20	6.38	6.39	2.94
125262GF	-	.71*	21	6.73	6.71	3.11
125262S	125262RS	1	21	6.73	6.71	3.11
125263S	125263RS	1-1/4	21	6.73	6.71	3.11
125264S	125264RS	1-7/16	21	6.73	6.71	3.11
125265S	125265RS	1-1/2	21	6.73	6.71	3.11

*Plain bore pilot hole. Not sized to a shaft.



Split Sprockets & Idlers

Sprockets for Chain-Belts Series: 2252 FT, 2252 PT, LBP 2251

Sprocket features include excellent wear and chemical resistance, reduced noise levels, and a reinforced design. The completely closed structure is easier to clean and disinfect, plus the design of the sprocket ensures smooth running and a long service life. These sprockets float freely and can be used on the drive shaft and on the idler shaft.

Note:

- Single keyway sprockets can be used for belt widths up to 26 inches and temperature differences of maximum 86°F.
- For wider belts or bigger temperature differences, sprockets with square bores or round bore with two keyways have to be used.

To order single keyway sprockets capable of floating freely on the shaft (i.e. shaft sized bore +.01 /+.02), just add the letter "P" (=plus) to the existing part number. For example, code **123099SP**.

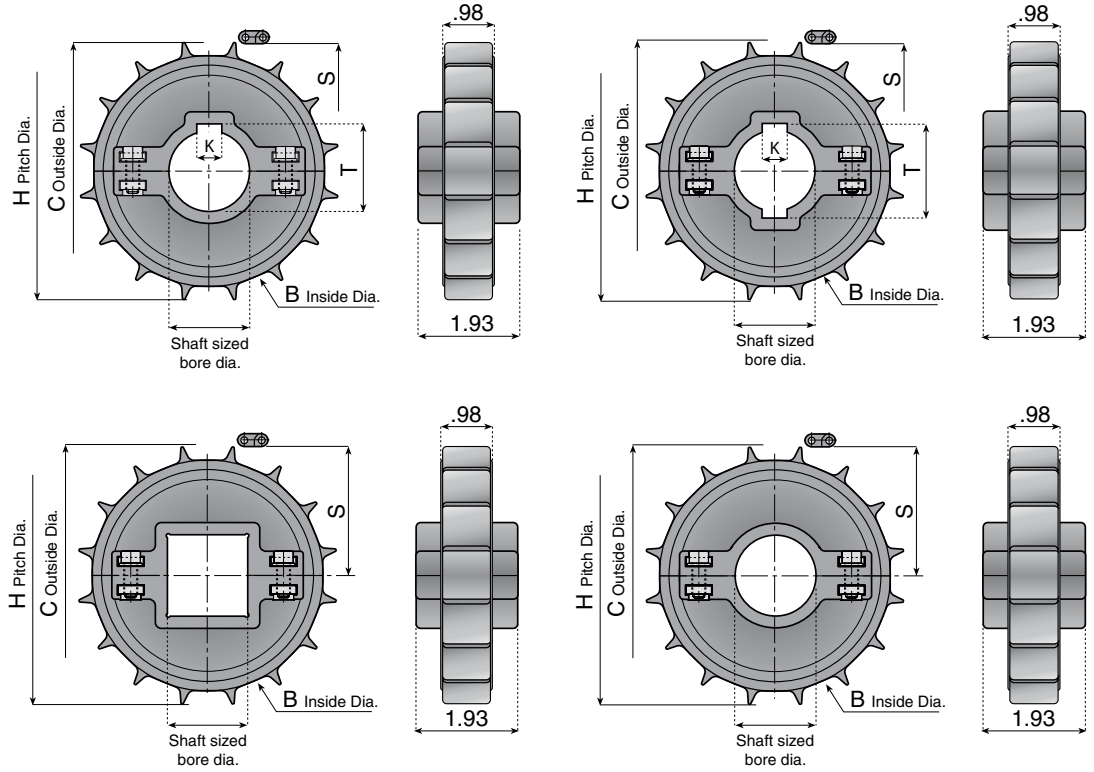
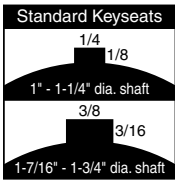

Sprockets, Wear Strips, Chain Guides

Material: Polyamide body with stainless steel connecting screws and nuts in nickel plated brass.

Single Keyway Sprocket Part Number	Double Keyway Sprocket Part Number	Square Bore Sprocket Part Number	Idler Part Number	Shaft Sized Bore Dia.	Number of Teeth	Inside Diameter B	Outside Diameter C	Pitch Diameter H	Shaft Center to Wear Surface S (+0 to .04)
123150S	123154S	-	123162S	1-1/4	14	3.90	4.48	4.50	2.00
123151S	123155S	-	123163S	1-7/16	14	3.90	4.48	4.50	2.00
123152S	123156S	-	123164S	1-1/2	14	3.90	4.48	4.50	2.00
-	-	123066S	-	1-1/2 x 1-1/2 sq.	16	4.53	5.12	5.13	2.31
123057S	123061S	-	123067S	1-1/4	16	4.53	5.12	5.13	2.31
123058S	123062S	-	123068S	1-7/16	16	4.53	5.12	5.13	2.31
123059S	123063S	-	123069S	1-1/2	16	4.53	5.12	5.13	2.31
123060S	123064S	-	123070S	1-3/4	16	4.53	5.12	5.13	2.31
-	-	123080S	-	1-1/2 x 1-1/2 sq.	18	5.17	5.67	5.76	2.63
123071S	123075S	-	123081S	1-1/4	18	5.17	5.67	5.76	2.63
123072S	123076S	-	123082S	1-7/16	18	5.17	5.67	5.76	2.63
123073S	123077S	-	123083S	1-1/2	18	5.17	5.67	5.76	2.63
123074S	123078S	-	123084S	1-3/4	18	5.17	5.67	5.76	2.63
-	-	123094S	-	1-1/2 x 1-1/2 sq.	20	5.80	6.38	6.39	2.95
123085S	123089S	-	123095S	1-1/4	20	5.80	6.38	6.39	2.95
123086S	123090S	-	123096S	1-7/16	20	5.80	6.38	6.39	2.95
123087S	123091S	-	123097S	1-1/2	20	5.80	6.38	6.39	2.95
123088S	123092S	-	123098S	1-3/4	20	5.80	6.38	6.39	2.95



Sprockets, Wear Strips, Chain Guides

Sprockets & Idlers

Sprockets for CC 1400 and CC 1431 Series Case/Crate Conveyor Chains

These sprockets have been machined from solid polyamide material, giving them a completely closed structure which is easier to clean and disinfect. The reinforced design of the sprocket ensures smooth running with reduced noise levels.

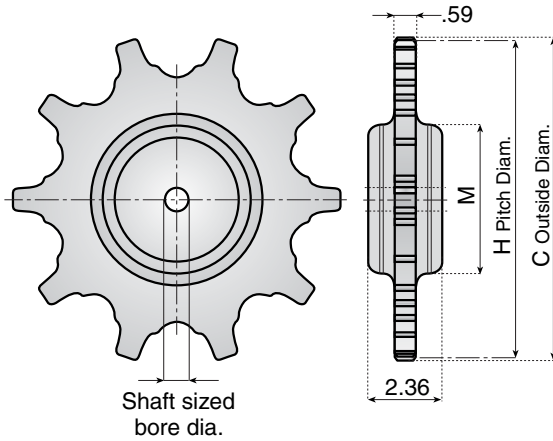

Material: Polyamide body.

Sprocket Part Number	Shaft Sized Bore Dia.	Number of Teeth	Outside Diameter C	Pitch Diameter H	M
12331	.79*	7	8.27	7.48	2.95
12332	.79*	8	9.06	8.58	3.54
12333	.79*	9	10.12	9.53	4.92
12334	.79*	10	11.06	10.51	4.92

*Plain bore pilot hole. Not sized to a shaft.

Sprockets & Idlers

Sprockets for CC 1400 and CC 1431 Series Case/Crate Conveyor Chains

These sprockets have been machined from solid polyamide material, giving them a completely closed structure which is easier to clean and disinfect. The reinforced design of the sprocket ensures smooth running with reduced noise levels. Additional benefits include increased keyway strength, excellent chemical resistance, and long service life.

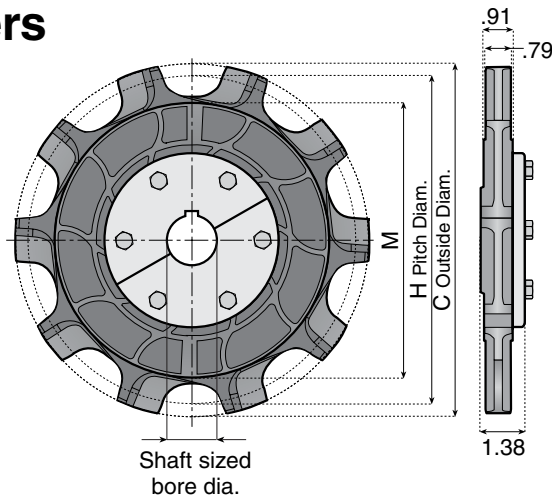

Material: Polyamide body.

Sprocket Part Number	Shaft Sized Bore Dia.	Number of Teeth	Outside Diameter C	Pitch Diameter H	M
32970V	1	10	11.06	10.30	8.61
32971V	1-1/4	10	11.06	10.30	8.61
32972V	1-1/2	10	11.06	10.30	8.61

*Plain bore pilot hole. Not sized to a shaft.



Sprockets & Idlers

Sprockets for CC 600 Series Case/Crate Conveyor Chains

These sprockets have been machined from solid polyamide material, giving them a completely closed structure which is easier to clean and disinfect. The reinforced design of the sprocket ensures smooth running with reduced noise levels.

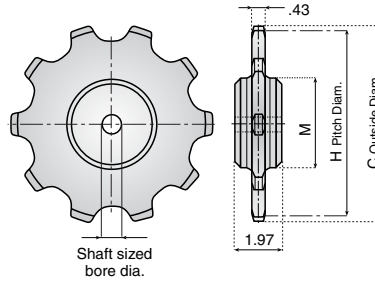

Sprockets, Wear Strips, Chain Guides

Material: Polyamide body.

Sprocket Part Number	Shaft Sized Bore Dia.	Number of Teeth	Outside Diameter C	Pitch Diameter H	M
12326	.79*	8	6.77	6.54	3.78
12327	.79*	10	8.47	8.07	3.78
12328	.79*	12	10.10	9.69	3.78
12329	.79*	14	11.70	11.26	3.78

*Plain bore pilot hole. Not sized to a shaft.

Split Sprockets & Idlers

Sprockets for Multiflex Chain

These sprockets have been machined from solid polyamide material, giving them a completely closed structure which is easier to clean and disinfect. The reinforced design of the sprocket ensures smooth running with reduced noise levels. Additional benefits include increased keyway strength, excellent chemical resistance, and long service life.

Special shape of the sprocket teeth compensates for natural chain lengthening after prolonged use!



Drive Sprocket

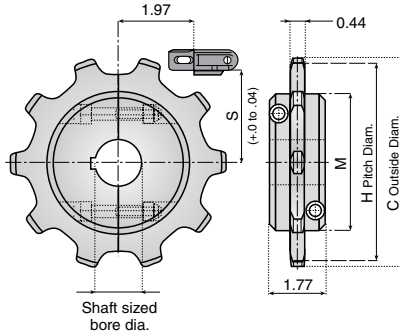

Idler Sprocket

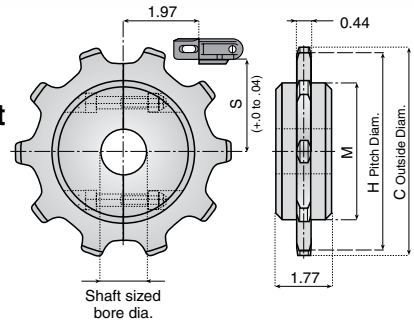

For HACCP Needs!

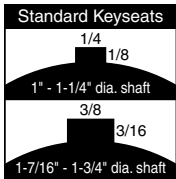

Positioning pins ensure accurate tooth alignment and aid assembly.

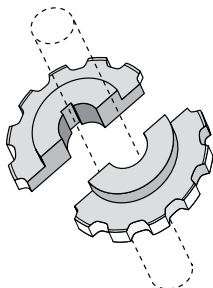

Save installation time with split sprockets and idler wheels.

Material: Polyamide body, stainless steel connecting screws.

Sprocket Part Number	Reference Code	Idler Part Number	Reference Code	Shaft Sized Bore Dia.	Number of Teeth	Outside Diameter C	Pitch Diameter H	M	Shaft Center to Wear Surface S (+0 to .04)
12730	1700-8MP-.71	-	-	.71*	8	5.37	5.07	3.15	2.09
32731	1700-8MP-1	32736	1700-8MP-IDL-1	1	8	5.37	5.07	3.15	2.09
32732	1700-8MP-1.25	32737	1700-8MP-IDL-1.25	1-1/4	8	5.37	5.07	3.15	2.09
32733	1700-8MP-1.44	32738	1700-8MP-IDL-1.44	1-7/16	8	5.37	5.07	3.15	2.09
32734	1700-8MP-1.5	32739	1700-8MP-IDL-1.5	1-1/2	8	5.37	5.07	3.15	2.09
12745	1700-10MP-.71	-	-	.71*	10	6.50	6.37	4.33	2.72
32746	1700-10MP-1	32741	1700-10MP-IDL-1	1	10	6.50	6.37	4.33	2.72
32747	1700-10MP-1.25	32742	1700-10MP-IDL-1.25	1-1/4	10	6.50	6.37	4.33	2.72
32748	1700-10MP-1.44	32743	1700-10MP-IDL-1.44	1-7/16	10	6.50	6.37	4.33	2.72
32749	1700-10MP-1.5	32744	1700-10MP-IDL-1.5	1-1/2	10	6.50	6.37	4.33	2.72
12750	1700-13MP-.71	-	-	.71*	13	8.46	8.22	5.91	3.68
32751	1700-13MP-1	32756	1700-13MP-IDL-1	1	13	8.46	8.22	5.91	3.68
32752	1700-13MP-1.25	32757	1700-13MP-IDL-1.25	1-1/4	13	8.46	8.22	5.91	3.68
32753	1700-13MP-1.44	32758	1700-13MP-IDL-1.44	1-7/16	13	8.46	8.22	5.91	3.68
32754	1700-13MP-1.5	32759	1700-13MP-IDL-1.5	1-1/2	13	8.46	8.22	5.91	3.68

*Plain bore pilot hole. Not sized to a shaft.



Tangential Sprockets

Sprockets for Chain Series:
878TAB

Sprockets, Wear
Strips, Chain Guides

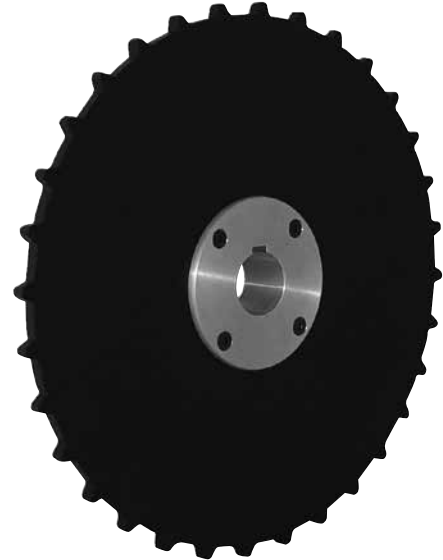
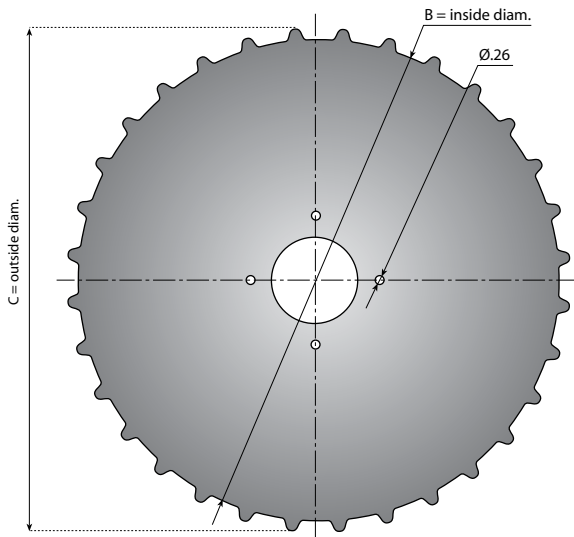
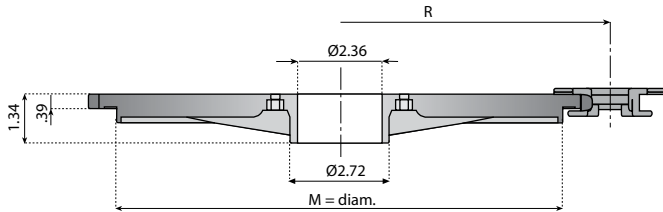

Material: Black polyamide.

Part Number	Number of Teeth	Inside Diameter B	Outside Diameter C	M	R
12781L	32	13.23	13.89	12.24	7.87
12782L	34	14.11	14.70	13.13	7.87

Machined Hub

For tangential sprockets

Can be machined to obtain a variety of shaft diameters. The hub attaches to the tangential sprocket with 4 stainless steel nuts and screws.

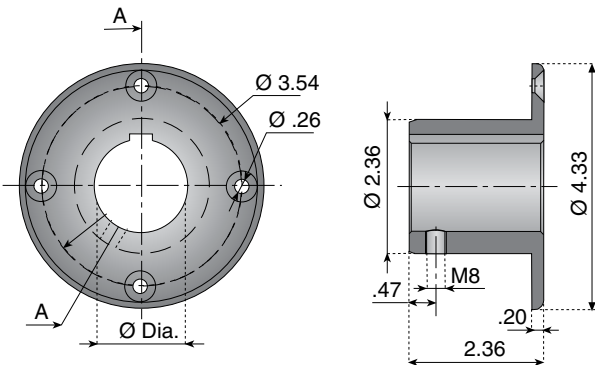

Material: Aluminum.

Part Number	Shaft Sized Bore Dia.
12772G	.71*

*Plain bore pilot hole. Not sized to a shaft.



Turning Disk - Closed

Carry and Return for Chain Series:
881 TAB, 878 TAB

Radial ball bearings for 25 mm shafts included.

Material: Black polyamide.

Part Number	Equivalent Number of Teeth	Diameter B	Chain Radius R
12779	32	13.27	7.48
12780	34	14	7.87

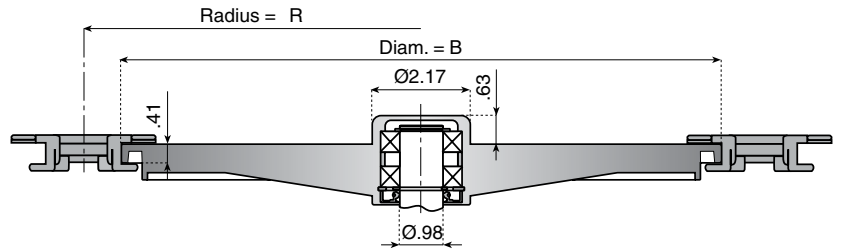

Sprockets, Wear Strips, Chain Guides

Turning Disk - Open

Carry and Return for Chain Series:
881 TAB, 878 TAB

Radial ball bearings for 25 mm shafts included.

Material: Black polyamide.

Part Number	Equivalent Number of Teeth	Diameter B	Chain Radius R
12777	32	13.27	7.48
12778	34	14	7.87

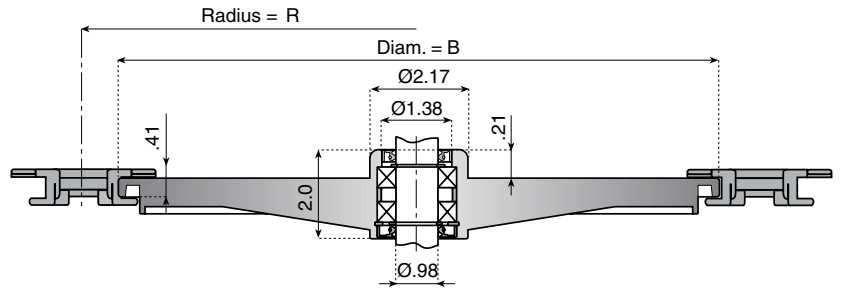

Components

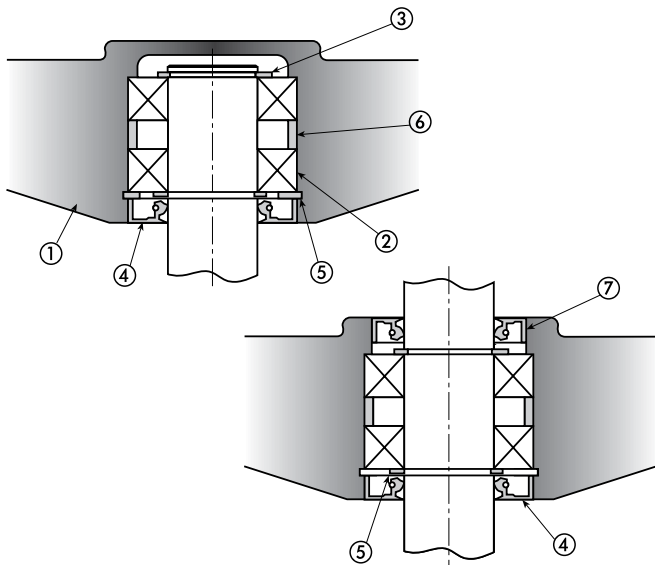

- 1 -Turning disk.
- 2 -Single race radial ball bearing with two sliding seals, type 6005-2RS (25x47x12).
- 3 -External (retaining) ring, Ø 25 DIN471.
- 4 -Seal ring with dust cover, 25x47x7 DIN 3760 (NBR rubber).
- 5 -Internal (retaining) ring, Ø 47 DIN472.
- 6 -Bearing spacer.
- 7 -Seal ring with dust cover, 25x42x7 DIN3760 (NBR rubber).

All components are supplied separate, except the shaft bearings which are pre-assembled.

Dimensions

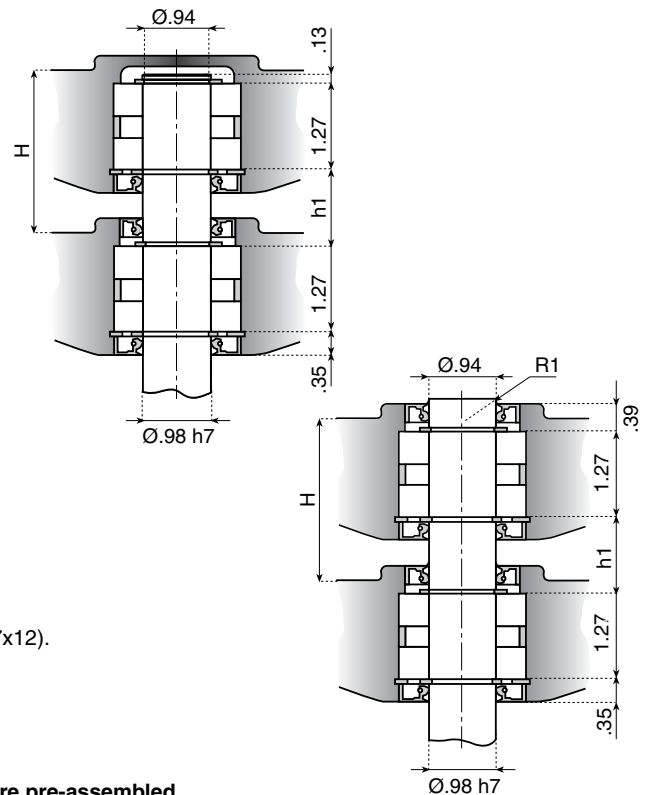



Sprockets, Wear
Strips, Chain Guides

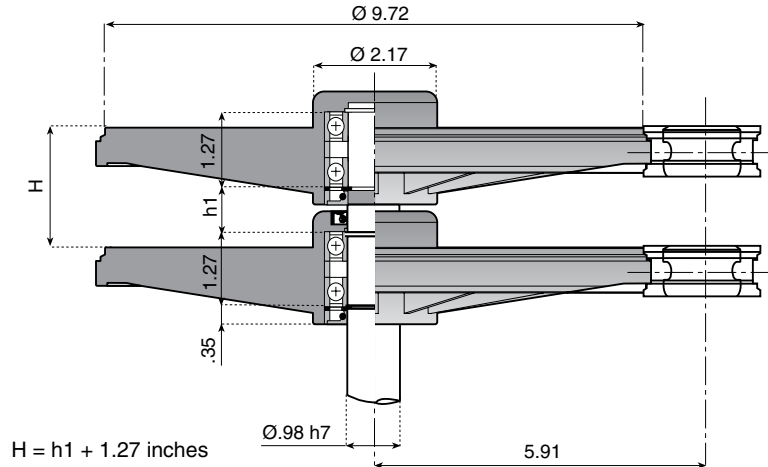

Turning Disk - Closed

Carry and Return for Chain Series:
1701 TAB

Radial ball bearings for 25 mm shafts included.

Material: Black polyamide.

Part Number

12783

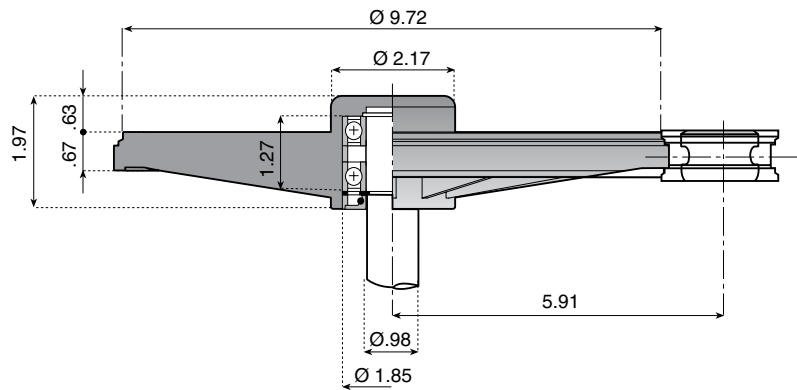

All components are supplied separate, except the shaft bearings which are pre-assembled.



The Simple Solution for Tab and Bevel Style Conveyor Chains!

Sprockets, Wear Strips, Chain Guides

ValuTrac™ straight and corner modules are designed to guide side flexing steel and plastic conveyor chains. ValuTrac has proven to be a cost effective improvement over fabricated straight and corner wear strips. ValuTrac is manufactured with state of the art computer controlled machinery, assuring parallel module sides and a smooth uniform chain guiding surface. When it is necessary to modify or replace a guideway, ValuTrac's modular design will make the job easier. ValuTrac's quality and consistency assure conveyor chain guiding that is reliable and long lasting.



✓ Selection of Materials

Our standard series ValuTrac is precision machined from Nolu-BR, a black, proprietary blend of UHMW resins, or Nolu-S, a grey, self lubricating UHMW blend. These materials maintain excellent chemical and corrosion resistance, while providing low friction, superior rigidity, and resistance to wear. ValuTrac is also available in Nolu-SR for applications requiring greater wear resistance, surface hardness, and lubricity due to adverse environmental conditions.

✓ Cost Savings

The modular design of ValuTrac™ significantly reduces fabrication time. Fewer parts require fewer fasteners, fewer connections and fewer supports. The result is an overall time and cost savings.

For specific coefficients of friction and operating temperatures, please see the technical information on page 465.

Tab Style

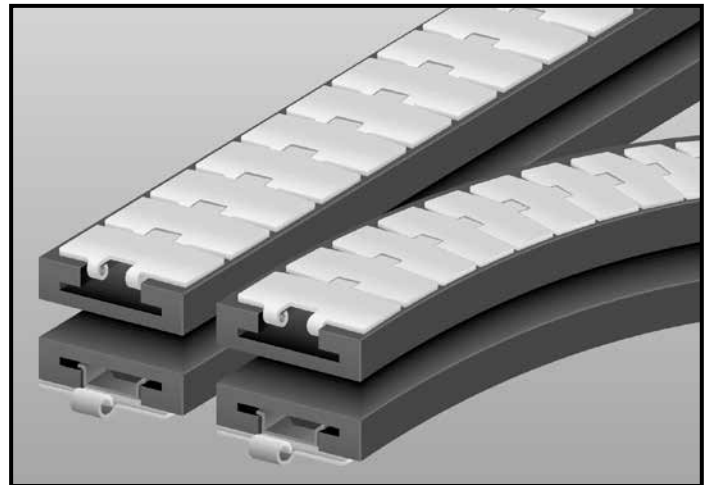
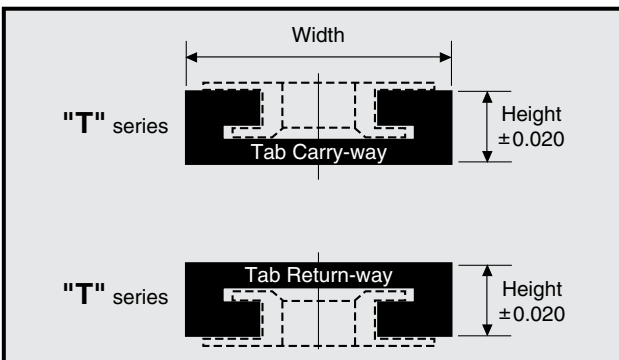

ValuTrac for tab style chains is the same for carry-way or return-way.

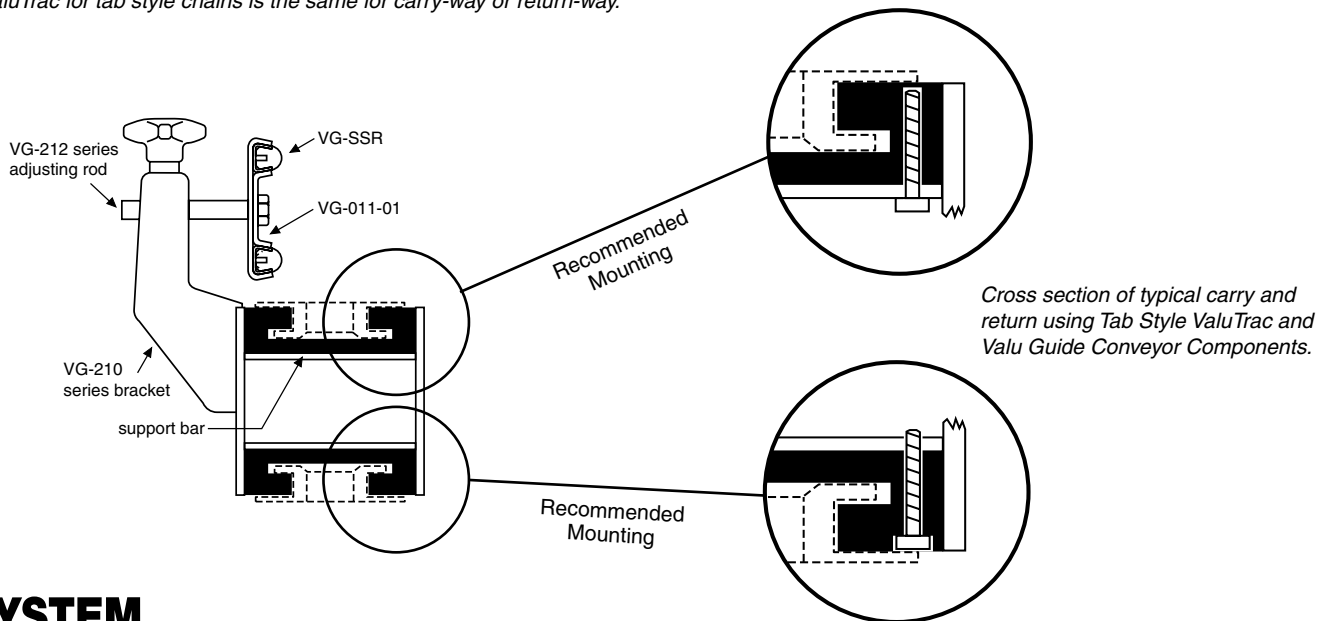



Curves for Tab Chain



Sprockets, Wear Strips, Chain Guides

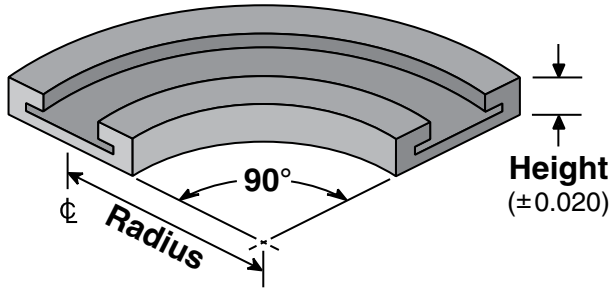

ValuTrac™ for tab chains can be used as carry-ways, or flipped upside down and used as return-ways.



NOLU-BR	NOLU-S	NOLU-SR
Nolu-BR UHMW is our standard track material. It is a proprietary blend of resins and reground UHMW that maximizes wear and friction properties for most applications.	Nolu-S is a blend of UHMW and other dry lubricants that maintains good wear characteristics while significantly reducing the track's coefficient of friction.	Nolu-SR combines the Nolu-S features with a much harder, longer wearing composition which can be used in most high-speed/high-load applications previously requiring Nylatron material.

Chain Number	Track Width	Track Height	Carry or Return	Radius	Nolu-BR Part Number	Nolu-S Part Number	Nolu-SR Part Number
879TAB-K3-1/4 880TAB-K3-1/4 881TAB-K3-1/4	3.75	1		18	VT-980-T-18-0325	VT-S-980-T-18-0325	VT-SR-980-T-18-0325
24				VT-980-T-24-0325	VT-S-980-T-24-0325	VT-SR-980-T-24-0325	
879TAB-K4-1/2 880TAB-K4-1/2 881TAB-K4-1/2	5	1		24	VT-980-T-24-0450	VT-S-980-T-24-0450	VT-SR-980-T-24-0450
* 881TAB-K7-1/2	8	1		24	VT-981-T-24-0750	VT-S-981-T-24-0750	VT-SR-981-T-24-0750
882TAB-K4-1/2	5	1.188		24	VT-982-T-24-0450	VT-S-982-T-24-0450	VT-SR-982-T-24-0450
882TAB-K7-1/2	8	1.188		24	VT-982-T-24-0750	VT-S-982-T-24-0750	VT-SR-982-T-24-0750
882TAB-K10	10.5	1.188		24	VT-982-T-24-1000	VT-S-982-T-24-1000	-
882TAB-K12	12.5	1.188		24	VT-982-T-24-1200	VT-S-982-T-24-1200	VT-SR-982-T-24-1200
1843	2	1		10	VT-943-T-10-0150	-	-
				18	VT-943-T-18-0150	-	-
				24	VT-943-T-24-0150	-	-
* 1873-K3-1/4 1874-K3-1/4	3.75	1.375		18	VT-973-T-18-0325	VT-S-973-T-18-0325	VT-SR-973-T-18-0325
24				VT-973-T-24-0325	VT-S-973-T-24-0325	VT-SR-973-T-24-0325	
1873-K4-1/2 1874-K4-1/2	5	1.375		18	-	-	-
				24	VT-973-T-24-0450	VT-S-973-T-24-0450	VT-SR-973-T-24-0450
1873-K6 1874-K6	6.5	1.375		18	-	-	-
				24	VT-973-T-24-0600	-	-
1873-K7-1/2 1874-K7-1/2	8	1.375		18	VT-973-T-18-0750	-	-
				24	VT-973-T-24-0750	-	-

Chains typically used with ValuTrac™ Tab Modules:

Chain Number	1843	1843G	1701TAB	1873-	1873G	1874-	1874G
ValuTrac Module	943-T series		901-T series	973-T series			

See page 138 for custom module ordering instructions.

Chain number	879TAB-	880TAB-	881TAB-K3 1/4, 4 1/2	881TAB-K7 1/2	882TAB-	LBP882T-
ValuTrac Module	980-T series			981-T series	982-T series	

NOTE: Specialty chain styles such as gripper and low back pressure use the same ValuTrac module as the standard sideflexing counterpart. Example: Chain no. 1873G (grripper style) uses the same module as standard chain no. 1873-. For 815, 820, or 831 style chain, use ValuTrac part number VT-980-T.

* These ValuTrac modules are commonly used on side gripping, elevator/lowerator systems.



Straight Sections for Tab Chain

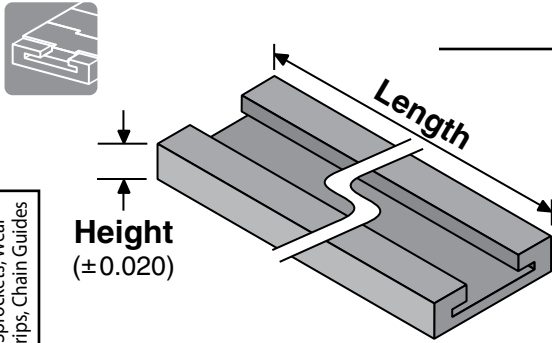

NOLU-BR	NOLU-S
Nolu-BR UHMW is our standard track material. It is a proprietary blend of resins and reground UHMW that maximizes wear and friction properties for most applications.	Nolu-S is a blend of UHMW and other dry lubricants that maintains good wear characteristics while significantly reducing the track's coefficient of friction.

Can Ship UPS
(3 & 6 ft. lengths)

ValuTrac™ for tab chains can be used as carry-ways, or flipped upside down and used as return-ways.

Chain Number	Track Width	Track Height	Carry or Return	Length in Feet	Nolu-BR Part Number	Nolu-S Part Number
879TAB-K3-1/4 880TAB-K3-1/4 881TAB-K3-1/4	3.75	1		3	VT-980-T-S-0325-3	VT-S-980-T-S-0325-3
				6	VT-980-T-S-0325-6	VT-S-980-T-S-0325-6
				10	VT-980-T-S-0325-10	VT-S-980-T-S-0325-10
879TAB-K4-1/2 880TAB-K4-1/2 881TAB-K4-1/2	5	1		3	VT-980-T-S-0450-3	-
				6	VT-980-T-S-0450-6	VT-S-980-T-S-0450-6
				10	VT-980-T-S-0450-10	VT-S-980-T-S-0450-10
881TAB-K7-1/2	8	1		3	VT-981-T-S-0750-3	VT-S-981-T-S-0750-3
				6	VT-981-T-S-0750-6	-
				10	VT-981-T-S-0750-10	VT-S-981-T-S-0750-10
* 882TAB-K4-1/2	5	1.188		3	VT-982-T-S-0450-3	VT-S-982-T-S-0450-3
				6	VT-982-T-S-0450-6	VT-S-982-T-S-0450-6
				10	VT-982-T-S-0450-10	VT-S-982-T-S-0450-10
882TAB-K7-1/2	8	1.188		3	VT-982-T-S-0750-3	VT-S-982-T-S-0750-3
				6	VT-982-T-S-0750-6	VT-S-982-T-S-0750-6
				10	VT-982-T-S-0750-10	VT-S-982-T-S-0750-10
882TAB-K10	10.5	1.188		3	VT-982-T-S-1000-3	-
				6	VT-982-T-S-1000-6	VT-S-982-T-S-1000-6
				10	VT-982-T-S-1000-10	VT-S-982-T-S-1000-10
882TAB-K12	12.5	1.188		3	-	VT-S-982-T-S-1200-3
				6	VT-982-T-S-1200-6	-
				10	VT-982-T-S-1200-10	VT-S-982-T-S-1200-10
1843	2	1		3	VT-943-T-S-0150-3	-
				6	VT-943-T-S-0150-6	-
				10	VT-943-T-S-0150-10	-
* 1873-K3-1/4 1874-K3-1/4	3.75	1.375		3	VT-973-T-S-0325-3	-
				6	VT-973-T-S-0325-6	VT-S-973-T-S-0325-6
				10	VT-973-T-S-0325-10	VT-S-973-T-S-0325-10
1873-K4-1/2 1874-K4-1/2	5	1.375		3	VT-973-T-S-0450-3	-
				6	VT-973-T-S-0450-6	-
				10	VT-973-T-S-0450-10	-
1873-K6 1874-K6	6.5	1.375		3	-	-
				6	-	-
				10	VT-973-T-S-0600-10	-
1873-K7-1/2 1874-K7-1/2	8	1.375		3	-	-
				6	VT-973-T-S-0750-6	-
				10	VT-973-T-S-0750-10	-
1701TAB	3.25	1.25		3	VT-901-T-S-0209-3	-
				6	VT-901-T-S-0209-6	-
				10	VT-901-T-S-0209-10	-

*These ValuTrac modules are commonly used on side gripping, elevator/lowerator systems.



Bevel Style

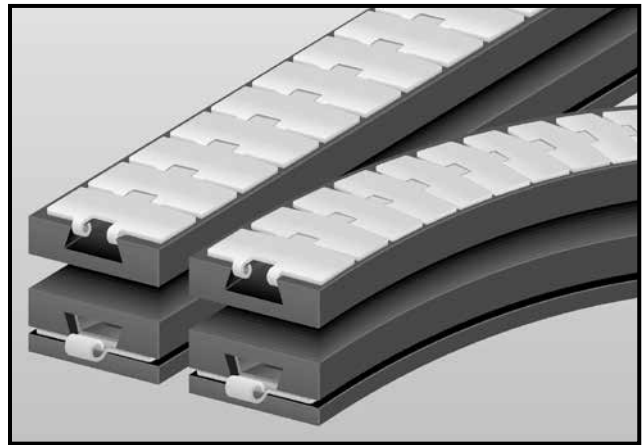
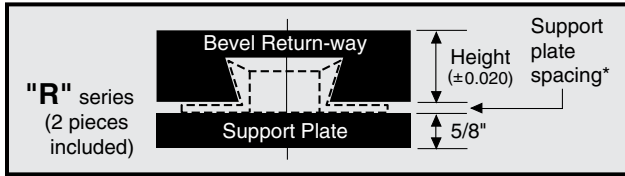
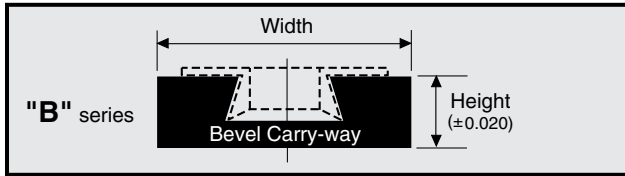

Sprockets, Wear Strips, Chain Guides

ValuTrac™ for bevel chains use a 1 piece track for carry-ways. Return-ways consist of 2 pieces, the track and a 5/8" thick chain support plate.

* Support plate spacing: 879=(7/32") 880=(3/16") 881=(5/32") 882=(7/32")



Curves for Bevel Chain

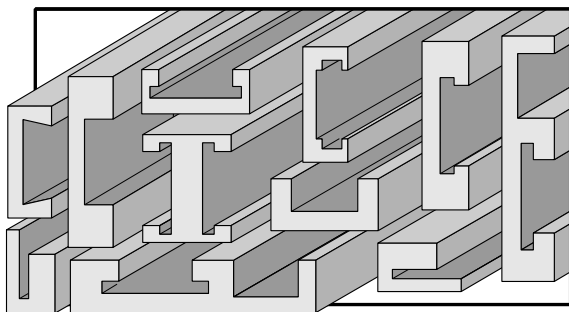
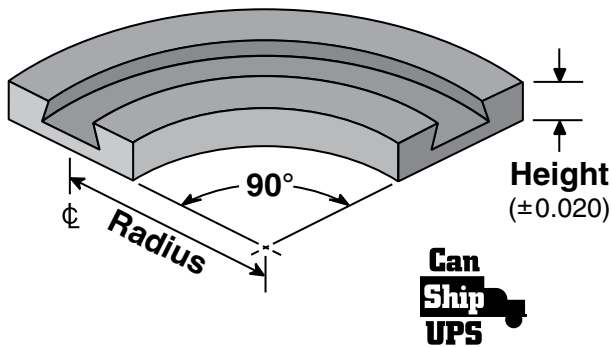

See page 138 for custom module ordering instructions.

NOLU-BR

Nolu-BR UHMW is our standard track material. It is a proprietary blend of resins and reground UHMW that maximizes wear and friction properties for most applications.

Chain Number	Track Width	Track Height	Carry or Return	Radius	Nolu-BR Part Number
879-K3-1/4 880-K3-1/4 881-K3-1/4	3.75	1	carry	18	VT-980-B-18-0325
				24	VT-980-B-24-0325
			return	18	VT-980-R-18-0325
				24	VT-980-R-24-0325
879-K4-1/2 880-K4-1/2 881-K4-1/2	5	1	carry	24	VT-980-B-24-0450
				24	VT-980-R-24-0450
			return	24	VT-980-R-24-0450
				24	VT-980-R-24-0450
881-K7-1/2	8	1	carry	24	VT-981-B-24-0750
				24	VT-981-R-24-0750
			return	24	VT-981-R-24-0750
				24	VT-981-R-24-0750
882-K4-1/2	5	1.188	carry	24	VT-982-B-24-0450
				24	VT-982-R-24-0450
			return	24	VT-982-R-24-0450
				24	VT-982-R-24-0450
882-K7-1/2	8	1.188	carry	24	VT-982-B-24-0750
				24	VT-982-R-24-0750
			return	24	VT-982-R-24-0750
				24	VT-982-R-24-0750
882-K10	10.5	1.188	carry	24	VT-982-B-24-1000

Note: Because the bottom dimensions of the 879, 880 and 881 chains are the same for widths up to 4 1/2", the VT-980 track is used for all three chains.



Straight Sections for Bevel Chain

NOLU-BR
 Nolu-BR UHMW is our standard track material. It is a proprietary blend of resins and reground UHMW that maximizes wear and friction properties for most applications.

Sprockets, Wear Strips, Chain Guides

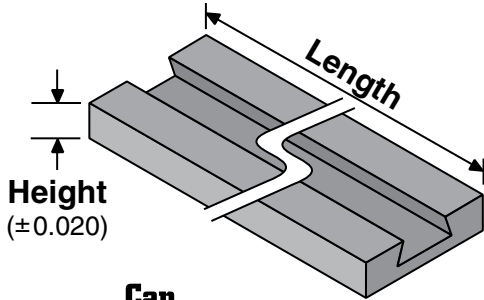

Can Ship UPS
 (3 & 6 ft. lengths)

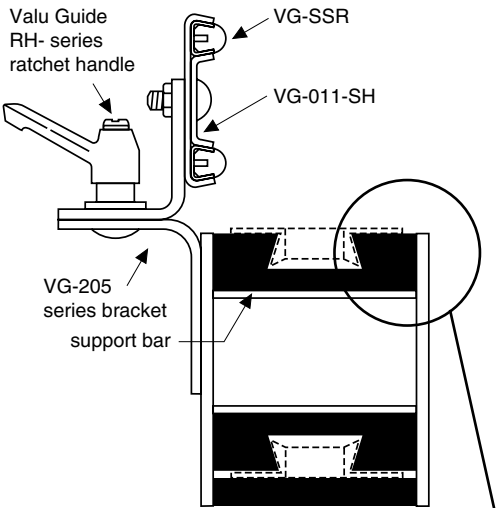

Cross section of typical carry and return using Bevel Style ValuTrac and Valu Guide Conveyor Components.

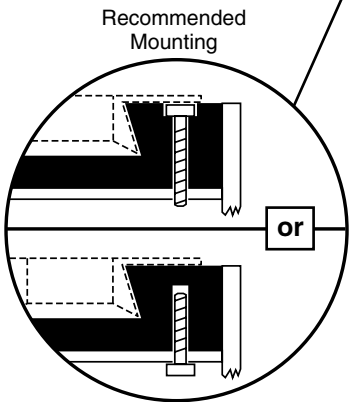

Chain Number	Track Width	Track Height	Carry or Return	Length in Feet	Nolu-BR Part Number
879-K3-1/4 880-K3-1/4 881-K3-1/4	3.75	1	carry	3	VT-980-B-S-0325-3
				6	VT-980-B-S-0325-6
				10	VT-980-B-S-0325-10
			return	3	VT-980-R-S-0325-3
				6	VT-980-R-S-0325-6
				10	VT-980-R-S-0325-10
879-K4-1/2 880-K4-1/2 881-K4-1/2	5	1	carry	3	VT-980-B-S-0450-3
				6	VT-980-B-S-0450-6
				10	VT-980-B-S-0450-10
			return	10	VT-980-R-S-0450-10
881-K7-1/2	8	1	carry	3	VT-981-B-S-0750-3
				6	VT-981-B-S-0750-6
				10	VT-981-B-S-0750-10
			return	10	VT-981-R-S-0750-10
882-K4-1/2	5	1.188	carry	3	VT-982-B-S-0450-3
				6	VT-982-B-S-0450-6
				10	VT-982-B-S-0450-10
882-K7-1/2	8	1.188	carry	6	VT-982-B-S-0750-6
				10	VT-982-B-S-0750-10
			return	6	VT-982-R-S-0750-6
				10	VT-982-R-S-0750-10
882-K10	10.5	1.188	carry	3	VT-982-B-S-1000-3
				6	VT-982-B-S-1000-6
				10	VT-982-B-S-1000-10
			return	10	VT-982-R-S-1000-10

Note: Because the bottom dimensions of the 879, 880 and 881 chains are the same for widths up to 4½", the VT-980 track is used for all three chains.

Chains typically used with ValuTrac™ Bevel Modules

Chain Number	879-	880-	881-K3¼, 4½	881-K7½	882-
ValuTrac Module	980-B or -R series			981-B or -R series	982-B or -R series



Revolution in conveyor chain track

Sprockets, Wear Strips, Chain Guides

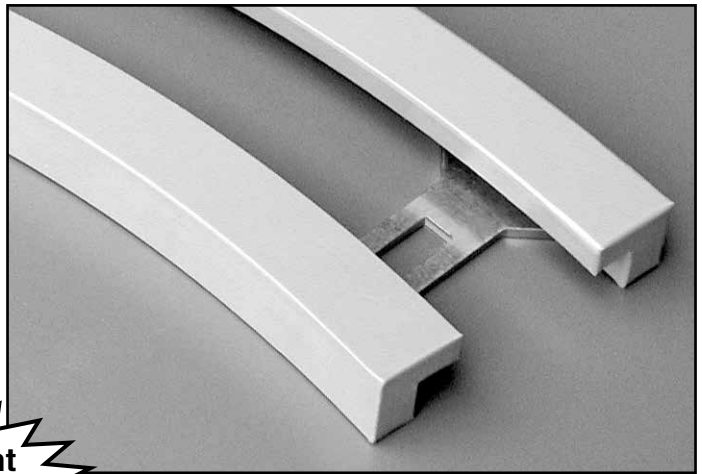
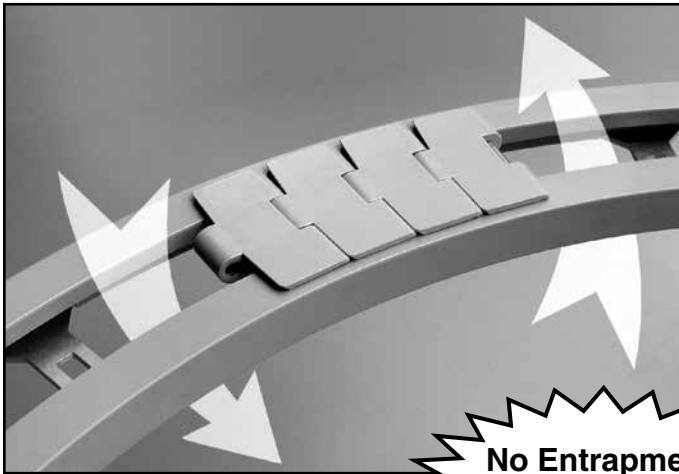

No Entrapment or Debris Buildup Areas!

VT2

ValuTrac II

Combines the durability and low friction of our engineered plastic wear materials with sturdy stainless steel mounting plates. This makes mounting and replacement easy and quick.



Patent No. 6,964,333

- Stainless steel mounting plates.
- Standardized geometry for fast, repeatable installations.
- No entrapment or debris buildup areas - easy cleaning.
- Variety of track materials.
- Available for most popular chain sizes.
- Precision manufactured to exacting standards.

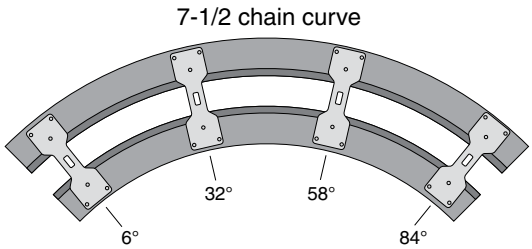
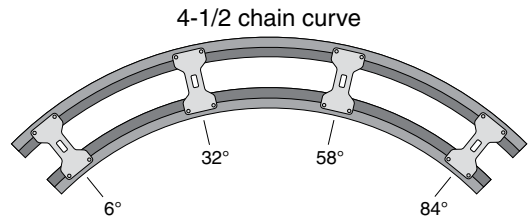
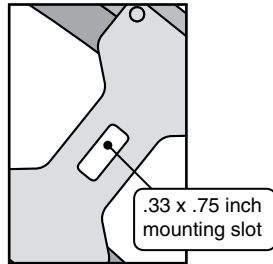
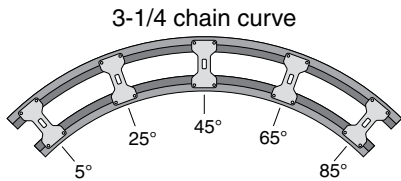

Chains typically used with ValuTrac II™ Tab Modules:

Chain Number	1873-	1873G	1874-	1874G
ValuTrac II Module	973-T-series			

Chain number	879TAB-	880TAB-	881TAB-K3/4, 4 1/2	882TAB-	LBP882T-
ValuTrac II Module	980-T-series			982-T-series	

NOTE: Specialty chain styles such as gripper and low back pressure use the same ValuTrac II module as the standard sideflexing counterpart. Example: Chain no. 1873G (gripper style) uses the same module as standard chain no. 1873-.

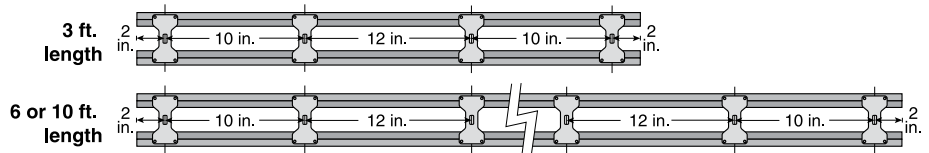



Curves for Tab Chain



Sprockets, Wear Strips, Chain Guides

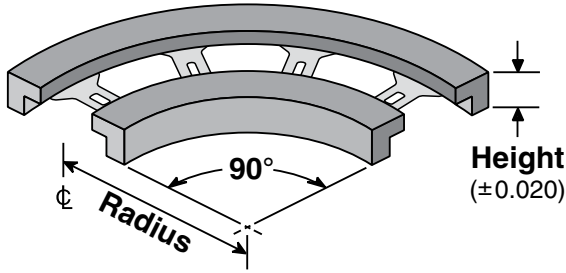

ValuTrac II™ for tab chains can be used as carry-ways, or flipped upside down and used as return-ways.

NOLU-BR	NOLU-S	NOLU-SR
Nolu-BR UHMW is our standard track material. It is a proprietary blend of resins and reground UHMW that maximizes wear and friction properties for most applications.	Nolu-S is a blend of UHMW and other dry lubricants that maintains good wear characteristics while significantly reducing the track's coefficient of friction.	Nolu-SR combines the Nolu-S features with a much harder, longer wearing composition which can be used in most high-speed/high-load applications previously requiring Nylatron material.

Chain Number	Track Width	Track Height	Carry or Return	Radius	Nolu-BR Part Number	Nolu-S Part Number	Nolu-SR Part Number
879TAB-K3-1/4 880TAB-K3-1/4 881TAB-K3-1/4	3.75	1		18	VT2-980-T-18-0325	VT2-S-980-T-18-0325	VT2-SR-980-T-18-0325
				24	VT2-980-T-24-0325	VT2-S-980-T-24-0325	VT2-SR-980-T-24-0325
879TAB-K4-1/2 880TAB-K4-1/2 881TAB-K4-1/2	5	1		24	VT2-980-T-24-0450	VT2-S-980-T-24-0450	VT2-SR-980-T-24-0450
882TAB-K4-1/2	5	1.188		24	VT2-982-T-24-0450	VT2-S-982-T-24-0450	VT2-SR-982-T-24-0450
881TAB-K7-1/2	8	1		24	-	VT2-S-981-T-24-0750	-
882TAB-K7-1/2	8	1.188		24	VT2-982-T-24-0750	VT2-S-982-T-24-0750	VT2-SR-982-T-24-0750
1873-K3-1/4 1874-K3-1/4	3.75	1.375		24	VT2-973-T-24-0325	-	VT2-SR-973-T-24-0325

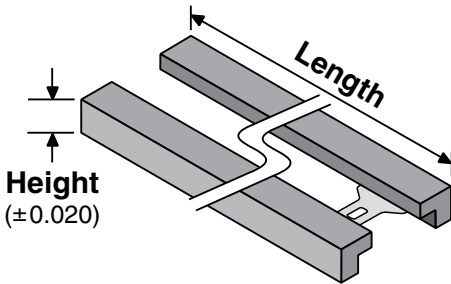

Straight Sections for Tab Chain



NOLU-BR	NOLU-S
Nolu-BR UHMW is our standard track material. It is a proprietary blend of resins and reground UHMW that maximizes wear and friction properties for most applications.	Nolu-S is a blend of UHMW and other dry lubricants that maintains good wear characteristics while significantly reducing the track's coefficient of friction.

Chain Number	Track Width	Track Height	Carry or Return	Length in Feet	Nolu-BR Part Number	Nolu-S Part Number
879TAB-K3-1/4 880TAB-K3-1/4 881TAB-K3-1/4	3.75	1		3	VT2-980-T-S-0325-3	VT2-S-980-T-S-0325-3
				6	VT2-980-T-S-0325-6	VT2-S-980-T-S-0325-6
				10	VT2-980-T-S-0325-10	VT2-S-980-T-S-0325-10
879TAB-K4-1/2 880TAB-K4-1/2 881TAB-K4-1/2	5	1		3	VT2-980-T-S-0450-3	VT2-S-980-T-S-0450-3
				6	VT2-980-T-S-0450-6	VT2-S-980-T-S-0450-6
				10	VT2-980-T-S-0450-10	VT2-S-980-T-S-0450-10
882TAB-K4-1/2	5	1.188		3	-	VT2-S-982-T-S-0450-3
				6	-	VT2-S-982-T-S-0450-6
				10	VT2-982-T-S-0450-10	VT2-S-982-T-S-0450-10
881TAB-K7-1/2	8	1		6	VT2-981-T-S-0750-6	-
				10	VT2-981-T-S-0750-10	-
882TAB-K7-1/2	8	1.188		3	VT2-982-T-S-0750-3	VT2-S-982-T-S-0750-3
				6	VT2-982-T-S-0750-6	VT2-S-982-T-S-0750-6
				10	VT2-982-T-S-0750-10	VT2-S-982-T-S-0750-10
1873-K3-1/4 1874-K3-1/4	3.75	1.375		10	VT2-973-T-S-0325-10	VT2-S-973-T-S-0325-10



Patent No. 6,964,333

Hybrid Curves for Tab Chain

NOLU-BR	NOLU-S	NOLU-SR
Nolu-BR UHMW is our standard track material. It is a proprietary blend of resins and reground UHMW that maximizes wear and friction properties for most applications.	Nolu-S is a blend of UHMW and other dry lubricants that maintains good wear characteristics while significantly reducing the track's coefficient of friction.	Nolu-SR combines the Nolu-S features with a much harder, longer wearing composition which can be used in most high-speed/high-load applications previously requiring Nylatron material.

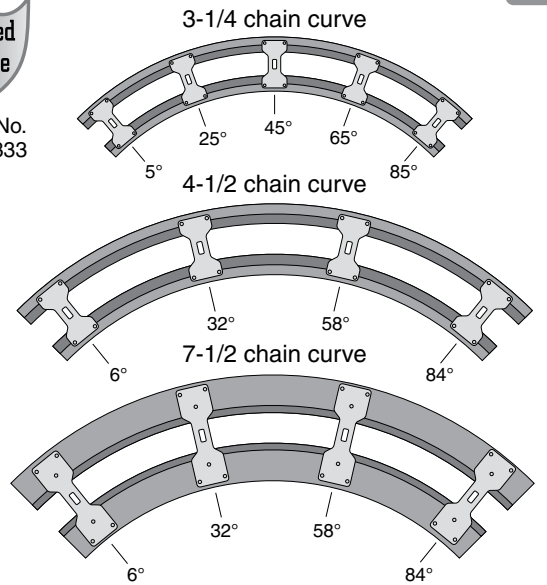

Sprockets, Wear Strips, Chain Guides

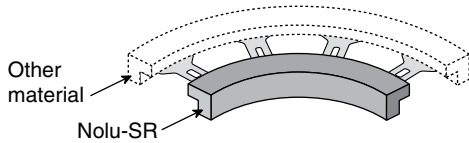

Most wear occurs on the inside portion of tracks. In some situations where Nolu-SR is necessary, ValuTrac III™ is an economical alternative to solid Nolu-SR curves.

Nolu-SR (inside) and Nolu-BR

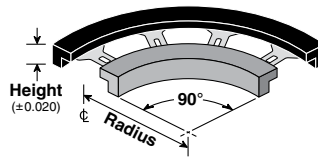

Nolu-SR (inside) and Nolu-S

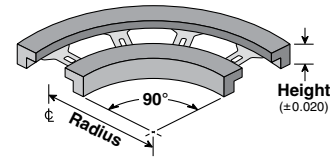

Chain Number	Track Width	Track Height	Carry or Return	Radius	Part Number	Part Number
879TAB-K3-1/4 880TAB-K3-1/4 881TAB-K3-1/4	3.75	1		24	VT3-SR-B-980-T-24-0325	-
879TAB-K4-1/2 880TAB-K4-1/2 881TAB-K4-1/2	5	1		24	VT3-SR-B-980-T-24-0450	VT3-SR-S-980-T-24-0450
882TAB-K4-1/2	5	1.188		24	VT3-SR-B-982-T-24-0450	VT3-SR-S-982-T-24-0450

Chains typically used with ValuTrac III™ Tab Modules:

Chain number	879TAB-	880TAB-	881TAB-K3¼, 4½	882TAB-	LBP882T-
ValuTrac III Module	980-T-series			982-T-series	

NOTE: Specialty chain styles such as gripper and low back pressure use the same ValuTrac II module as the standard sideflexing counterpart. Example: Chain no. 1873G (grripper style) uses the same module as standard chain no. 1873-.



Custom ValuTrac Sizes and Styles

ValuTrac™ is available in a wide variety of custom sizes and styles. One piece modules with angles up to 180° can be manufactured with special radius selections, widths, and thicknesses. Special styles include: multi-lane, multi-chain, kits for side gripper style elevators, lowerators, rinsers, and other styles of side flexing chain. Tangents are also available on custom corner modules.

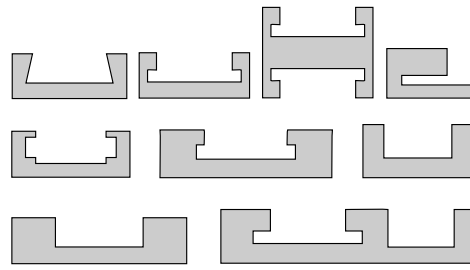

Additional ValuTrac custom modules

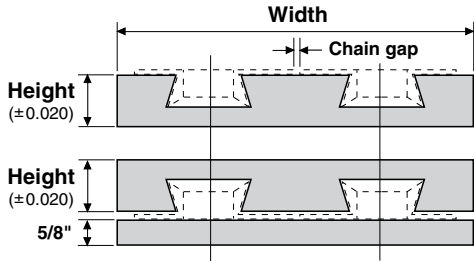

Section view of typical multi-lane bevel chain module

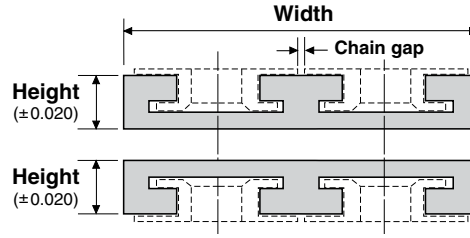

Section view of typical multi-lane tab chain module

Enter the information in the boxes below and fax to System Plast Customer Service at 866-447-6587.

Custom Straights Custom Turns

No. of carry modules	<input type="text"/>	<input type="text"/>
No. of return modules	<input type="text"/>	<input type="text"/>
Length (Overall length of module 6 feet typical)	<input type="text"/>	NOT APPLICABLE
Tangent length (if req.) (3 inches typical, both ends unless indicated)	NOT APPLICABLE	<input type="text"/>
Angle (in degrees)	NOT APPLICABLE	<input type="text"/>
Height (Overall height of module in inches)	<input type="text"/>	<input type="text"/>
Width* (Overall width of module considering all chain widths and chain gaps)	<input type="text"/>	<input type="text"/>
Edge Width (Edge of module to center- line of chain #1 in inches)	<input type="text"/>	<input type="text"/>
Chain Gap (Space between edges of chain)	<input type="text"/>	<input type="text"/>
Chain Style #1: (Example: 880 TAB K3 1/4)	<input type="text"/>	<input type="text"/>
Chain Style #2:	<input type="text"/>	<input type="text"/>
Chain Style #3:	<input type="text"/>	<input type="text"/>
Chain Style #4:	<input type="text"/>	<input type="text"/>

Person requesting custom information _____
 Company Name _____
 Phone _____ Fax _____

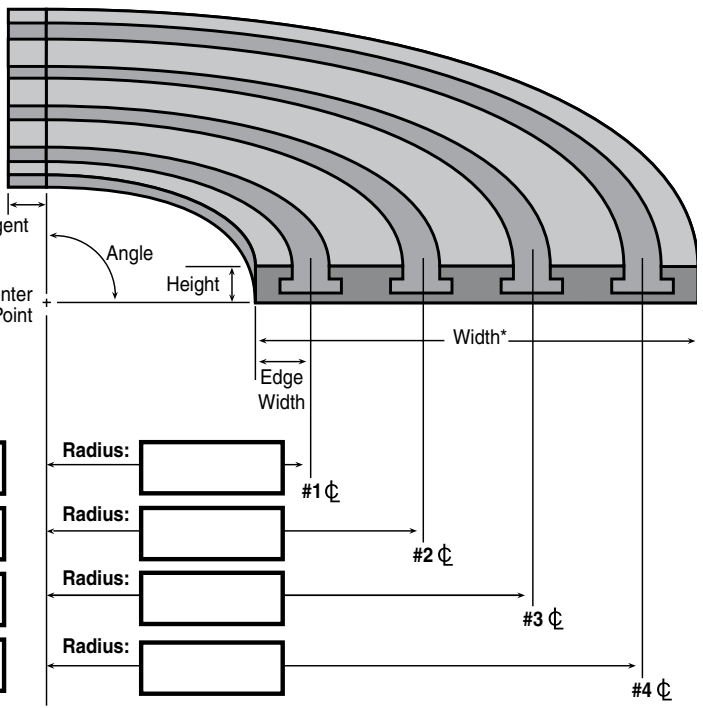

Material: (Please check one) Nolu-BR Black UHMW: Nolu-S Lubricated UHMW: Nolu-SR Lubricated UHMW: Virgin White UHMW:

Other: _____

***NOTE:** Please include the desired gap between each chain when calculating the overall module width. Recommended minimum gap is 1/16".



NARROW VALU TRAC™

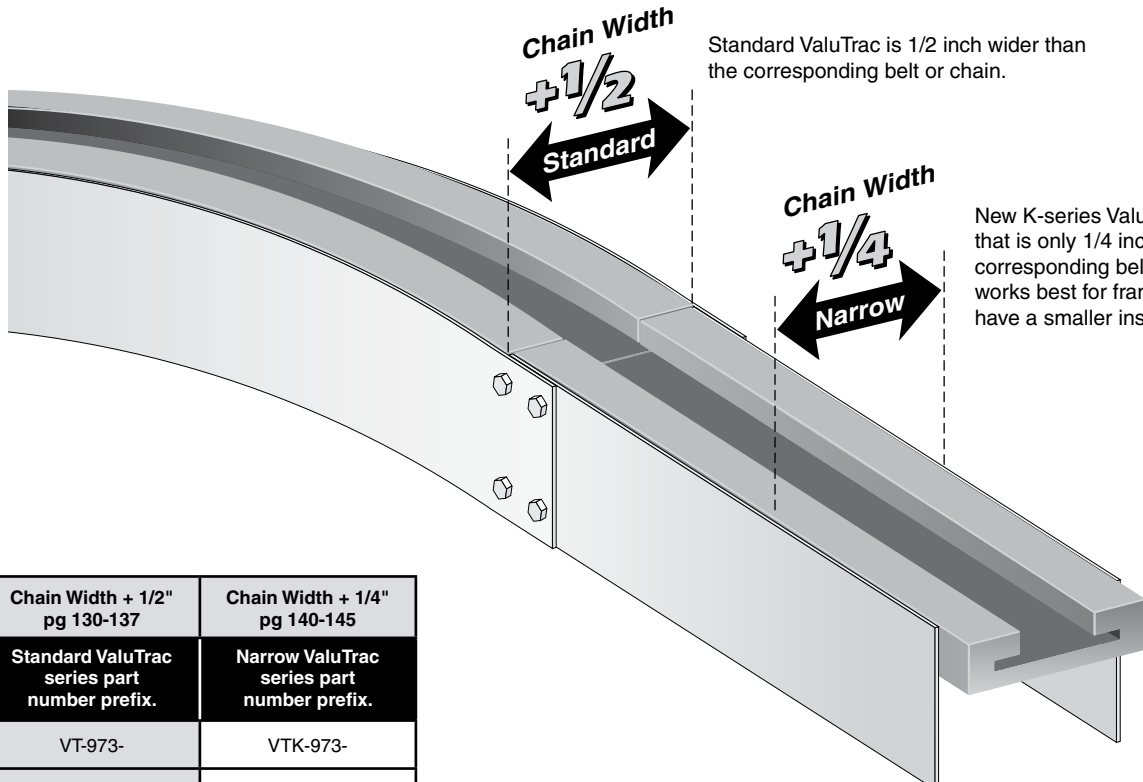

Standard ValuTrac is 1/2 inch wider than the corresponding belt or chain.

New K-series ValuTrac has a width that is only 1/4 inch wider than the corresponding belt or chain. This works best for frame designs that have a smaller inside dimension.

Sprockets, Wear Strips, Chain Guides

	Chain Width + 1/2" pg 130-137	Chain Width + 1/4" pg 140-145
	Standard ValuTrac series part number prefix.	Narrow ValuTrac series part number prefix.
VALU TRAC I	VT-973-	VTK-973-
	VT-S-973-	VTK-S-973-
	VT-SR-973-	VTK-SR-973-
	VT-980-	VTK-980-
	VT-S-980-	VTK-S-980-
	VT-SR-980-	VTK-SR-980-
	VT-981-	VTK-981-
	VT-982-	VTK-982-
	VT-S-982-	VTK-S-982-
	VT-SR-982-	VTK-SR-982-
VALU TRAC II	VT2-980-	VT2K-980-
	VT2-S-980-	VT2K-S-980-
	VT2-SR-980-	VT2K-SR-980-
	VT2-982-	VT2K-982-
	VT2-S-982-	VT2K-S-982-
	VT2-SR-982-	VT2K-SR-982-
VALU TRAC III	VT3-SR-B-980-	VT3K-SR-B-980-
	VT3-SR-S-980-	VT3K-SR-S-980-
	VT3-SR-B-982-	VT3K-SR-B-982-
	VT3-SR-S-982-	VT3K-SR-S-982-

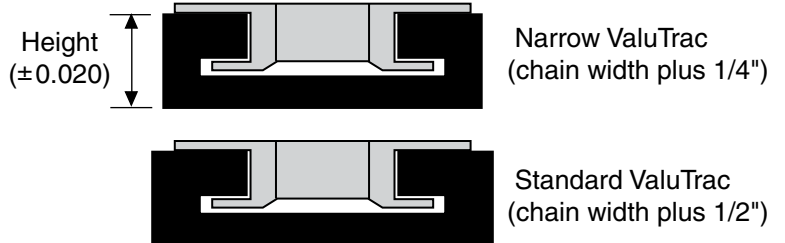

Typical conveyor frame construction methods:

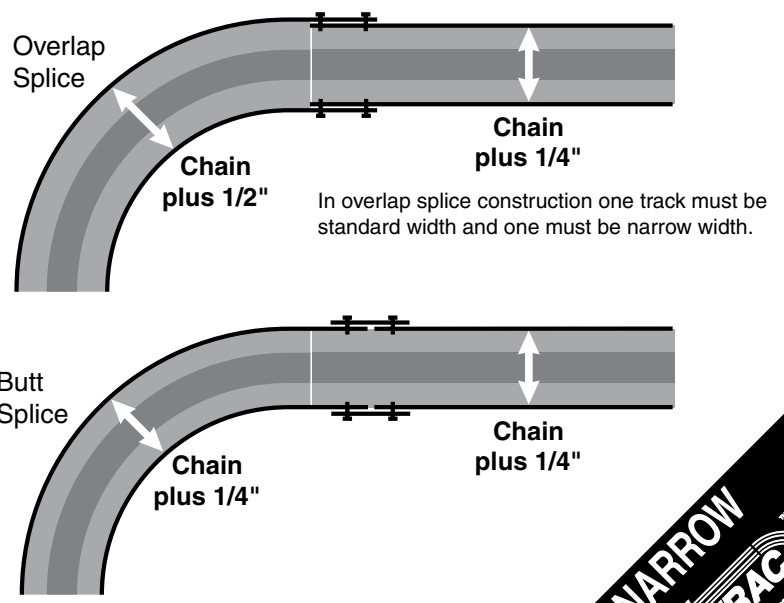

In overlap splice construction one track must be standard width and one must be narrow width.

NARROW VALU TRAC™
Chain width plus 1/4 inch



Narrow ValuTrac

NARROW VALU-TRAC

Curves for Tab Chain

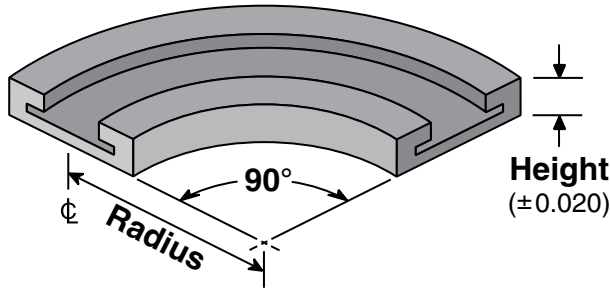

Sprockets, Wear Strips, Chain Guides

Narrow ValuTrac™ for tab chains can be used as carry-ways, or flipped upside down and used as return-ways.



				NOLU-BR	NOLU-S	NOLU-SR
				Nolu-BR UHMW is our standard track material. It is a proprietary blend of resins and reground UHMW that maximizes wear and friction properties for most applications.	Nolu-S is a blend of UHMW and other dry lubricants that maintains good wear characteristics while significantly reducing the track's coefficient of friction.	Nolu-SR combines the Nolu-S features with a much harder, longer wearing composition which can be used in most high-speed/high-load applications previously requiring Nylatron material.

Chain Number	Track Width	Track Height	Carry or Return	Radius	Nolu-BR Part Number	Nolu-S Part Number	Nolu-SR Part Number	
879TAB-K3-1/4	3.5	1		18	VTK-980-T-18-0325	VTK-S-980-T-18-0325	VTK-SR-980-T-18-0325	
880TAB-K3-1/4				24	VTK-980-T-24-0325	VTK-S-980-T-24-0325	VTK-SR-980-T-24-0325	
881TAB-K3-1/4								
879TAB-K4-1/2	4.75	1		24	VTK-980-T-24-0450	VTK-S-980-T-24-0450	VTK-SR-980-T-24-0450	
880TAB-K4-1/2								
881TAB-K4-1/2								
* 882TAB-K4-1/2	4.75	1.188		24	VTK-982-T-24-0450	VTK-S-982-T-24-0450	VTK-SR-982-T-24-0450	
882TAB-K7-1/2					VTK-982-T-24-0750	VTK-S-982-T-24-0750	VTK-SR-982-T-24-0750	
882TAB-K12					VTK-982-T-24-1200	VTK-S-982-T-24-1200	VTK-SR-982-T-24-1200	
1873-K4-1/2	4.75	1.375		18	VTK-973-T-18-0450	-	-	
1874-K4-1/2				24	VTK-973-T-24-0450	-	-	
1873-K7-1/2	7.75	1.375		24	VTK-973-T-24-0750	VTK-S-973-T-24-0750	VTK-SR-973-T-24-0750	
1874-K7-1/2								

Chains typically used with Narrow ValuTrac™ Tab Modules:

Chain Number	1873-	1873G	1874-	1874G		
Narrow ValuTrac	973-T-series					
Chain number	879TAB-	880TAB-	881TAB-K3 1/4, 4 1/2	881TAB-K7 1/2	882TAB-	LBP882T-
Narrow ValuTrac	980-T-series			981-T-series	982-T-series	

NOTE: Specialty chain styles such as gripper and low back pressure use the same Narrow ValuTrac module as the standard sideflexing counterpart. Example: Chain no. 1873G (grripper style) uses the same module as standard chain no. 1873-. For 815, 820, or 831 style chain, use Narrow ValuTrac part number VTK-980-T-

* These Narrow ValuTrac modules are commonly used on side gripping, elevator/lowerator systems.

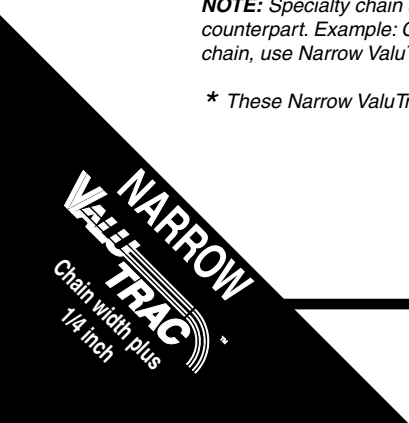



NARROW VALU TRAC

Straight Sections for Tab Chain

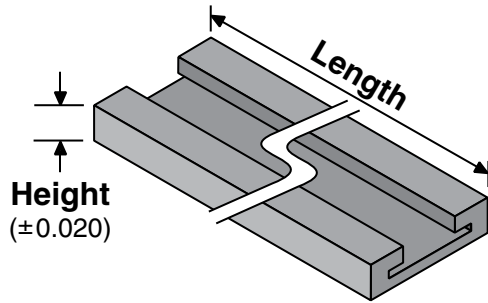

Narrow ValuTrac™ for tab chains can be used as carry-ways, or flipped upside down and used as return-ways.



(3 & 6 ft. lengths)

NOLU-BR	NOLU-S
Nolu-BR UHMW is our standard track material. It is a proprietary blend of resins and reground UHMW that maximizes wear and friction properties for most applications.	Nolu-S is a blend of UHMW and other dry lubricants that maintains good wear characteristics while significantly reducing the track's coefficient of friction.

Sprockets, Wear Strips, Chain Guides

Chain Number	Track Width	Track Height	Carry or Return	Length in Feet	Nolu-BR Part Number	Nolu-S Part Number
879TAB-K3-1/4 880TAB-K3-1/4 881TAB-K3-1/4	3.5	1		6	VTK-980-T-S-0325-6	-
				10	VTK-980-T-S-0325-10	VTK-S-980-T-S-0325-10
879TAB-K4-1/2 880TAB-K4-1/2 881TAB-K4-1/2	4.75	1		3	VTK-980-T-S-0450-3	-
				6	VTK-980-T-S-0450-6	-
				10	VTK-980-T-S-0450-10	VTK-S-980-T-S-0450-10
* 882TAB-K4-1/2	4.75	1.188		3	VTK-982-T-S-0450-3	-
				6	VTK-982-T-S-0450-6	-
				10	VTK-982-T-S-0450-10	-
882TAB-K7-1/2	7.75	1.188		3	-	VTK-S-982-T-S-0750-3
				6	VTK-982-T-S-0750-6	-
				10	VTK-982-T-S-0750-10	-
882TAB-K10	10.25	1.188		3	VTK-982-T-S-1000-3	-
				10	VTK-982-T-S-1000-10	-
* 1873-K3-1/4 1874-K3-1/4	3.5	1.375		3	VTK-973-T-S-0325-3	-
				6	-	VTK-S-973-T-S-0325-6
				10	VTK-973-T-S-0325-10	VTK-S-973-T-S-0325-10
1873-K4-1/2 1874-K4-1/2	4.75	1.375		10	VTK-973-T-S-0450-10	-
1873-K6 1874-K6	6.25	1.375		10	VTK-973-T-S-0600-10	-

*These Narrow ValuTrac modules are commonly used on side gripping, elevator/lowerator systems.





Curves for Bevel Chain



Straight Sections for Bevel Chain

Sprockets, Wear Strips, Chain Guides

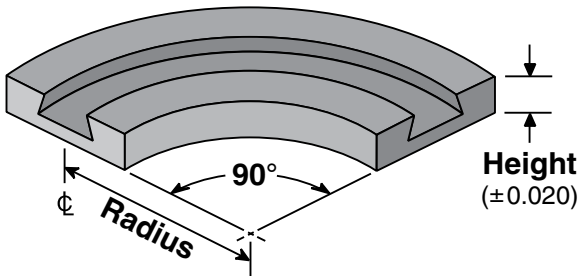

NOLU-BR
 Nolu-BR UHMW is our standard track material. It is a proprietary blend of resins and reground UHMW that maximizes wear and friction properties for most applications.

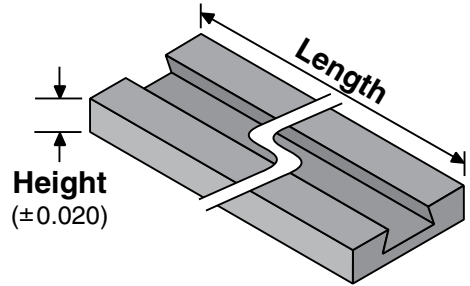

Chain Number	Track Width	Track Height	Carry or Return	Radius	Nolu-BR Part Number			
879-K3-1/4 880-K3-1/4 881-K3-1/4	3.5	1	Carry	18	VTK-980-B-18-0325			
				24	VTK-980-B-24-0325			
			Return	18	VTK-980-R-18-0325			
				24	VTK-980-R-24-0325			
879-K4-1/2 880-K4-1/2 881-K4-1/2	4.75	1	Carry	24	VTK-980-B-24-0450			
					Return	VTK-980-R-24-0450		
			Carry			7.75	1	24
					Return			
882-K4-1/2	4.75	1.188	Return	24		VTK-982-R-24-0450		
					882-K7-1/2	7.75	1.188	Carry
882-K10	10.25	1.188	Carry	24				

Chain Number	Track Width	Track Height	Carry or Return	Length (Feet)	Nolu-BR Part Number
879-K3-1/4 880-K3-1/4 881-K3-1/4	3.5	1	Carry	6	VTK-980-B-S-0325-6
				10	VTK-980-B-S-0325-10
879-K4-1/2 880-K4-1/2 881-K4-1/2	4.75	1	Carry	3	VTK-980-B-S-0450-3
				6	VTK-980-B-S-0450-6
				10	VTK-980-B-S-0450-10
881-K7-1/2	7.75	1	Carry	6	VTK-981-B-S-0750-6
				10	VTK-981-B-S-0750-10
882-K4-1/2	4.75	1.188	Carry	3	VTK-982-B-S-0450-3
				6	VTK-982-B-S-0450-6
				10	VTK-982-B-S-0450-10
882-K7-1/2	7.75	1.188	Carry	3	VTK-982-B-S-0750-3
				6	VTK-982-B-S-0750-6
882-K10	10.25	1.188	Carry	3	VTK-982-B-S-1000-3
				6	VTK-982-B-S-1000-6
				10	VTK-982-B-S-1000-10

Narrow ValuTrac™ for bevel chains use a 1 piece track for carry-ways. Return-ways consist of 2 pieces, the track and a 5/8" thick chain support plate. See page 133 for detailed drawing.

* Support plate spacing: 879=(7/32") 880=(3/16") 881=(5/32") 882=(7/32")

Note: Because the bottom dimensions of the 879, 880 and 881 chains are the same for widths up to 4 1/2", the VTK-980 track is used for all three chains.

Chains typically used with Narrow ValuTrac™ Bevel Modules

Chain Number	879-	880-	881-K3¼, 4½	881-K7½	882-
Narrow ValuTrac	980-B or -R series			981-B or -R series	982-B or -R series





NARROW VALU TRAC II TM Revolution in conveyor chain track

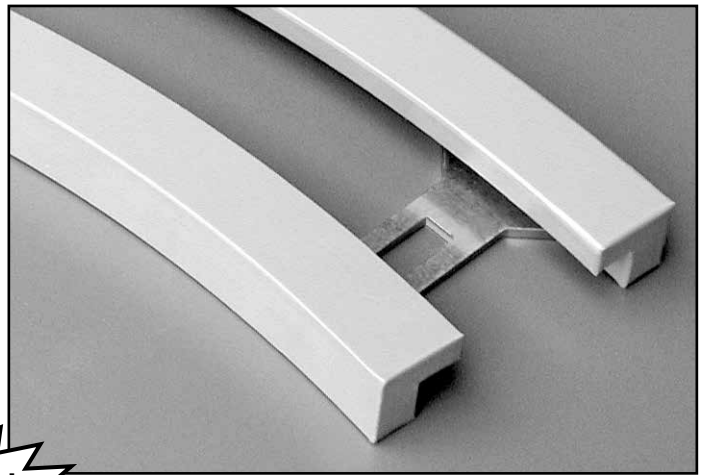
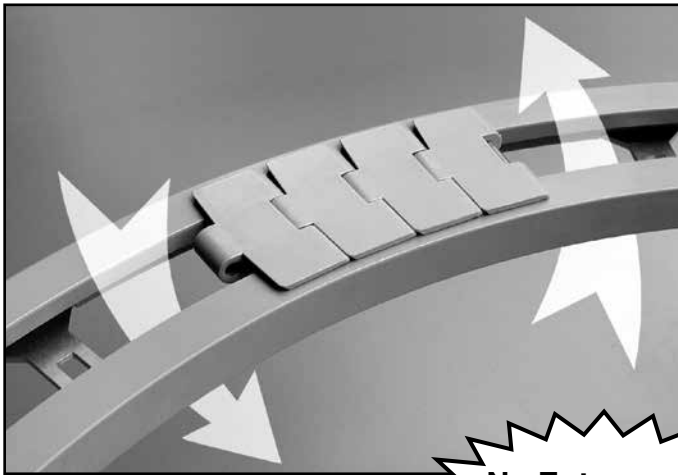

Sprockets, Wear Strips, Chain Guides

No Entrapment or Debris Buildup Areas!

VTK2

Narrow ValuTrac II

Combines the durability and low friction of our engineered plastic wear materials with sturdy stainless steel mounting plates. This makes mounting and replacement easy and quick.



Patent No. 6,964,333

- Stainless steel mounting plates.
- Standardized geometry for fast, repeatable installations.
- No entrapment or debris buildup areas - easy cleaning.
- Variety of track materials.
- Available for most popular chain sizes.
- Precision manufactured to exacting standards.

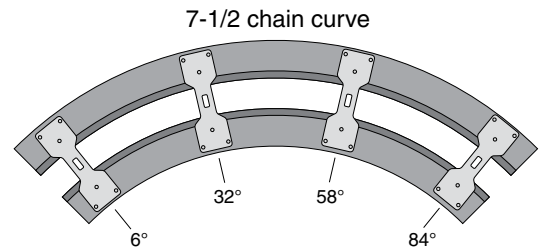
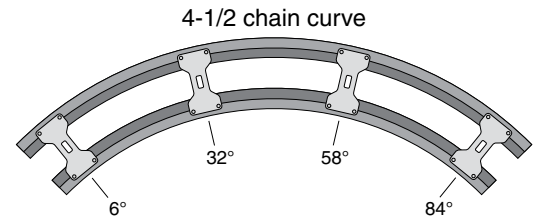
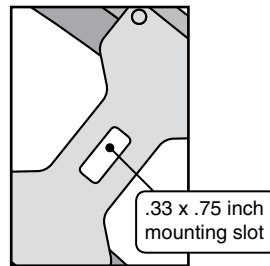
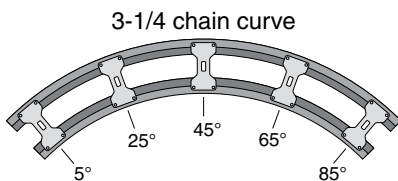

Chains typically used with Narrow ValuTrac II™ Tab Modules:

Chain Number	1873-	1873G	1874-	1874G
ValuTrac II Module	973-T-series			

Chain number	879TAB-	880TAB-	881TAB-K3/4, 4 1/2	882TAB-	LBP882T-
ValuTrac II Module	980-T-series				982-T-series

NOTE: Specialty chain styles such as gripper and low back pressure use the same ValuTrac II module as the standard sideflexing counterpart. Example: Chain no. 1873G (gripper style) uses the same module as standard chain no. 1873-.



Narrow ValuTrac II

NARROW VALU TRAC II Curves for Tab Chain



Patent No. 6,964,333

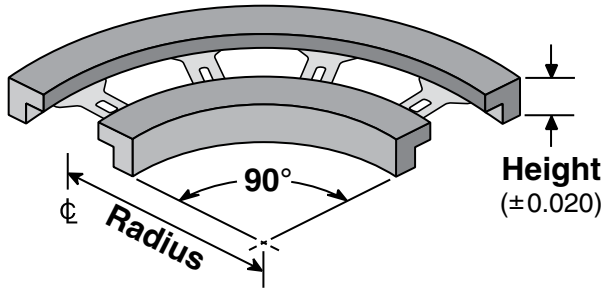

ValuTrac II™ for tab chains can be used as carry-ways, or flipped upside down and used as return-ways.

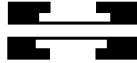

Chain Number	Track Width	Track Height	Carry or Return	Radius	Nolu-BR Part Number	Nolu-S Part Number	Nolu-SR Part Number
879TAB-K3-1/4 880TAB-K3-1/4 881TAB-K3-1/4	3.5	1		18	-	VT2K-S-980-T-18-0325	VT2K-SR-980-T-18-0325
				24	-	VT2K-S-980-T-24-0325	VT2K-SR-980-T-24-0325
879TAB-K4-1/2 880TAB-K4-1/2 881TAB-K4-1/2	4.75	1		24	VT2K-980-T-24-0450	VT2K-S-980-T-24-0450	VT2K-SR-980-T-24-0450
882TAB-K4-1/2	4.75	1.188		24	VT2K-982-T-24-0450	VT2K-S-982-T-24-0450	VT2K-SR-982-T-24-0450
1873-K3-1/4 1874-K3-1/4	3.5	1.375		24	-	-	VT2K-SR-973-T-24-0325

NOLU-BR
Nolu-BR UHMW is our standard track material. It is a proprietary blend of resins and reground UHMW that maximizes wear and friction properties for most applications.

NOLU-S
Nolu-S is a blend of UHMW and other dry lubricants that maintains good wear characteristics while significantly reducing the track's coefficient of friction.

NOLU-SR
Nolu-SR combines the Nolu-S features with a much harder, longer wearing composition which can be used in most high-speed/high-load applications previously requiring Nylatron material.

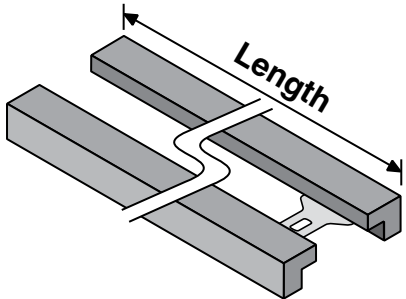

Straight Sections for Tab Chain



Chain Number	Track Width	Track Height	Carry or Return	Length in Feet	Nolu-BR Part Number	Nolu-S Part Number
879TAB-K3-1/4 880TAB-K3-1/4 881TAB-K3-1/4	3.5	1		3	-	VT2K-S-980-T-S-0325-3
				6	-	VT2K-S-980-T-S-0325-6
				10	VT2K-980-T-S-0325-10	VT2K-S-980-T-S-0325-10
879TAB-K4-1/2 880TAB-K4-1/2 881TAB-K4-1/2	4.75	1		3	VT2K-980-T-S-0450-3	VT2K-S-980-T-S-0450-3
				6	VT2K-980-T-S-0450-6	VT2K-S-980-T-S-0450-6
				10	VT2K-980-T-S-0450-10	VT2K-S-980-T-S-0450-10
882TAB-K4-1/2	4.75	1.188		3	-	VT2K-S-982-T-S-0450-3
				6	-	VT2K-S-982-T-S-0450-6
				10	-	VT2K-S-982-T-S-0450-10
1873-K3-1/4 1874-K3-1/4	3.5	1.375		10	VT2K-973-T-S-0325-10	VT2K-S-973-T-S-0325-10

NOLU-BR
Nolu-BR UHMW is our standard track material. It is a proprietary blend of resins and reground UHMW that maximizes wear and friction properties for most applications.

NOLU-S
Nolu-S is a blend of UHMW and other dry lubricants that maintains good wear characteristics while significantly reducing the track's coefficient of friction.

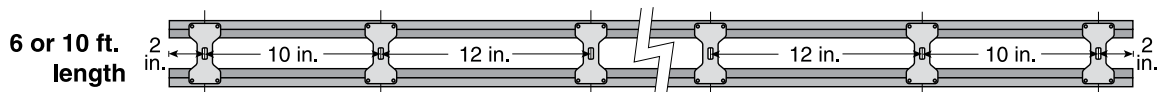
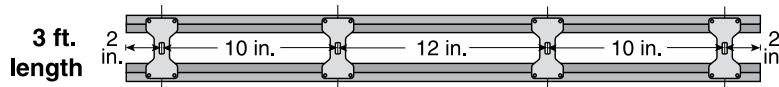



NARROW VALU TRAC III™

Hybrid Curves for Tab Chain

NOLU-BR	NOLU-S	NOLU-SR
Nolu-BR UHMW is our standard track material. It is a proprietary blend of resins and reground UHMW that maximizes wear and friction properties for most applications.	Nolu-S is a blend of UHMW and other dry lubricants that maintains good wear characteristics while significantly reducing the track's coefficient of friction.	Nolu-SR combines the Nolu-S features with a much harder, longer wearing composition which can be used in most high-speed/high-load applications previously requiring Nylatron material.



Patent No. 6,964,333

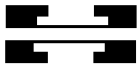

ValuTrac III™ for tab chains can be used as carry-ways, or flipped upside down and used as return-ways.

Nolu-SR (inside) and Nolu-BR

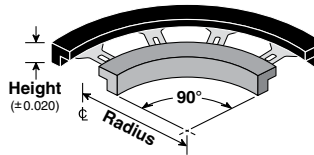

Nolu-SR (inside) and Nolu-S

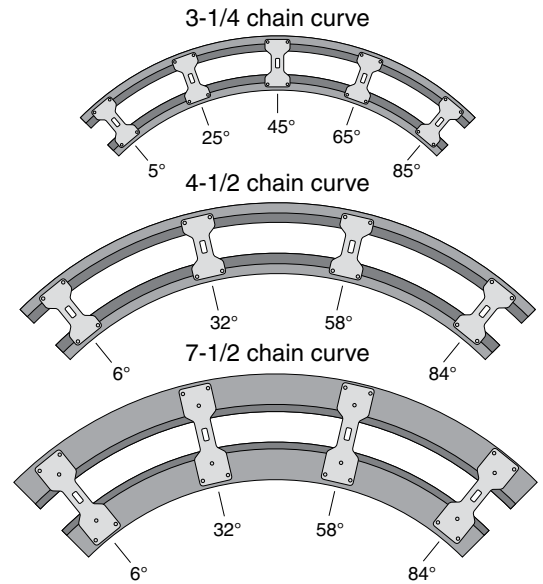
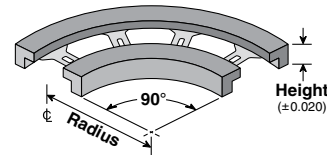

Sprockets, Wear Strips, Chain Guides

Chain Number	Track Width	Track Height	Carry or Return	Radius	Part Number	Part Number
879TAB-K3-1/4 880TAB-K3-1/4 881TAB-K3-1/4	3.5	1		18	VT3K-SR-B-980-T-18-0325	VT3K-SR-S-980-T-18-0325
				24	-	VT3K-SR-S-980-T-24-0325
879TAB-K4-1/2 880TAB-K4-1/2 881TAB-K4-1/2	4.75	1		24	-	VT3K-SR-S-980-T-24-0450
882TAB-K4-1/2	4.75	1.188		24	VT3K-SR-B-982-T-24-0450	VT3K-SR-S-982-T-24-0450



Chains typically used with ValuTrac III™ Tab Modules:

Chain Number	1873-	1873G	1874-	1874G	
ValuTrac III Module	973-T-series				
Chain number	879TAB-	880TAB-	881TAB-K3 1/4, 4 1/2	882TAB-	LBP882T-
ValuTrac III Module	980-T-series			982-T-series	

NOTE: Specialty chain styles such as gripper and low back pressure use the same ValuTrac II module as the standard sideflexing counterpart. Example: Chain no. 1873G (grripper style) uses the same module as standard chain no. 1873-





Magnetic Corner Tracks

Sprockets, Wear Strips, Chain Guides

CHARACTERISTICS

The Dual Magnetic System Curves are used in conjunction with stainless steel or plastic chains.

The chains are retained in the system by the magnetic field created by the magnets that are located within the curve material. The Dual Magnetic System chains and curves, compared to the older tab or bevel system, offer the user greater flexibility and improved efficiency as the design allows for easy removal of the chains from the curve - for cleaning and maintenance purposes. In this way, magnetic corner tracks contribute to TPM (Total Productive Maintenance) programs.

ADVANTAGES

Steel and Plastic chains can be used in the same curves which means simpler conveyor construction, reduced inventories and ultimately lower costs. Stainless Steel sideflexing magnetic retained chain has the same hinge width as the 815 series straight running chain and therefore uses the identical sprockets to the 815 series.

Easier maintenance construction

Magnetic retained chains do not incorporate the use of tab or bevel shoes, therefore, with a magnetic system, chains can be removed from the curve without dismantling the chain. As a result, maintenance and cleaning is easier which reduces downtime.

NEW MAGNETIC SYSTEM WITH METAL STRIP: "EXTRA" CURVES

System Plast has recently developed a new magnetic corner retention system for dry-running applications. The system, which is patent pending, sets new performance standards in magnet curve technology due to the inclusion of a unique metal strip mounted in the inside bearing face of the top section. This area is constantly under load due to the pressure/speed factor.

Main advantages:

- Extreme dissipation of heat significantly reduces wear.
- Under test conditions, lowest noise decibel levels were recorded.
- "Extra" curves are strongly recommended with plastic chains only!

MATERIAL

The standard upper section of the Dual Magnetic System curve is produced from 1200 grade UHMW-PE (ultra high molecular weight polyethylene) with the molecular weight exceeding 7.3 million g/mol., which ensures optimum wear life.

The return track is available in standard regenerated 1000 grade UHMW-PE (ultra high molecular weight polyethylene) with the molecular weight exceeding 4 million g/mol. This ensures a cost saving advantage for the end-user, as the wear on the return track is normally less significant than the top section.

Standard - The standard color of the upper section is waterblue, but it is also available in different colors subject to minimum order quantity. The return section is black regenerate material.

Nolu-S - This type of material is strongly recommended for steel and plastic chains with higher running speeds. The upper section is Nolu-S (light grey). The return section is black regenerate material.

Nolu-SR - This type of material is recommended for abrasive applications. The upper section is Nolu-SR (dark grey). The return section is black regenerate material.

All Nolu-S - The material of choice, strongly recommended for all types of chains (steel, plastic, and chain-belts). It significantly reduces coefficients of friction making it ideal for applications requiring reduced friction, noise reduction, and higher dry-running speeds. The upper and return sections are Nolu-S (light grey).

MAGNETIC PACKS

System Plast has developed special magnetic packs for the Dual Magnetic System curves. These unique magnet holders are located into slots machined in the upper section of the curve.

DESIGN AND FUNCTIONALITY

Dual Magnetic System curves have the magnets positioned on the outside of the center line radius of each track which results in a more effective counteracting through the curve. The positioning of the magnets in the Dual Magnetic System does not increase the chain load or friction, unlike other similar systems.

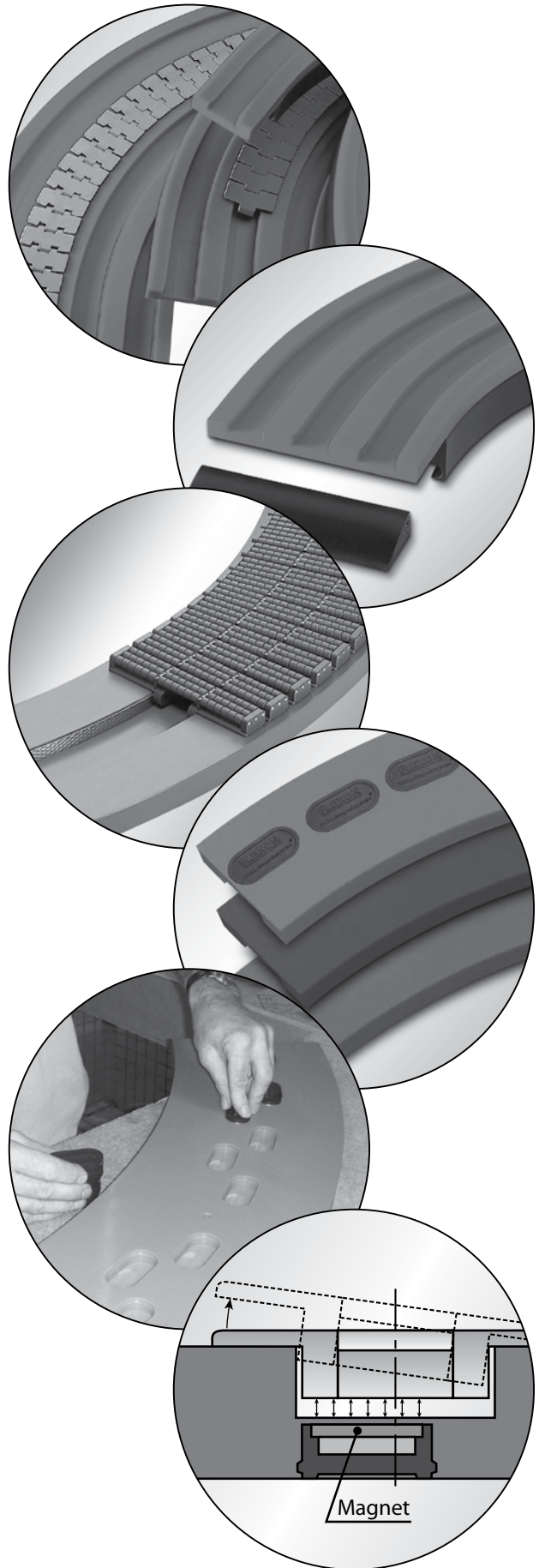

Magnetic Corner Tracks



K14

Magnetic Corner Tracks for Chain Series: K325, K330

The chains are retained in the system by a magnetic field created by magnets that are located within the track material. This design offers the user greater flexibility and improved efficiency by allowing easy removal of the chains from the curve for cleaning and maintenance purposes.

Radius: 610 mm, 24 inches



Tracks are available in four combinations of material. See page 146 for more information



Compatible with the following steel chains:
 SSL 881 MO K325 / 10208L
 SSEL 881 MO K325 / 10206L
 SSEL 881 MO K325 HB / 10213L
 SPSSL 881 MO K325 / 10255L
 SPSSL 881 MO K325 HB / 10265L



Tracks can be supplied with M8 or M10 threaded brass inserts (drawing required).

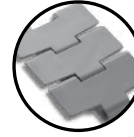

Compatible with the following plastic chains:
 LF 880 M K325 / 11377M
 LF 879 M K325 / 11395M
 XPG 880 M K325 / 11500MG
 XPG 879 M K325 / 11397MG
 NG 880 M K325 / 11195M
 NG 879 M K325 / 11198M

Sprockets, Wear Strips, Chain Guides

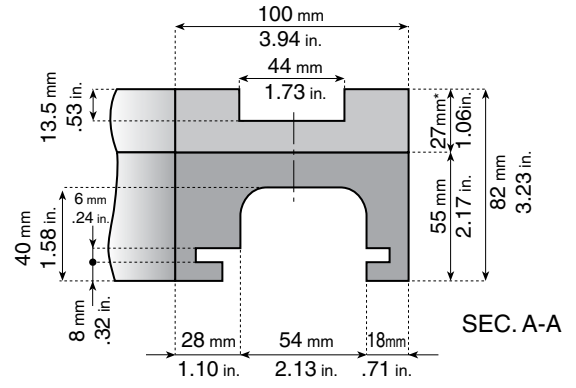
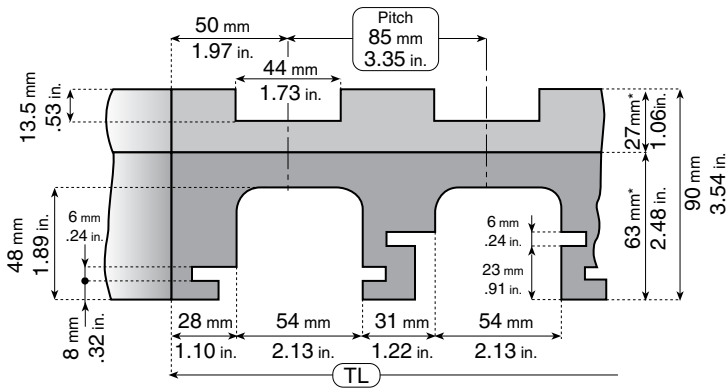

*Tolerance on 27mm and 63mm is ±0.35mm or 0.015".

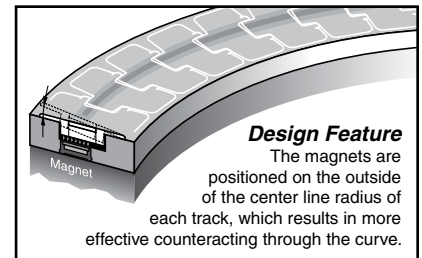
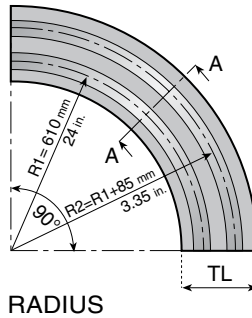
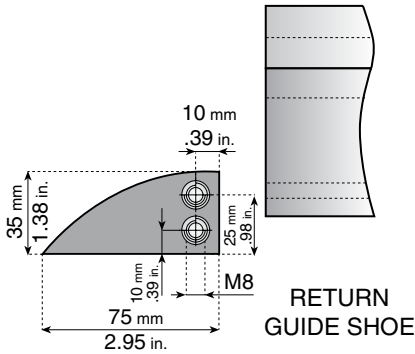

Standard
Part no. in table

Nolu-S
Add **NS** to part no.
(KMD.14.90.01.ANS)

Nolu-SR
Add **SR** to part no.
(KMD.14.90.01.ASR)

All Nolu-S
Add **2NS** to part no.
(KMD.14.90.01.A2NS)

Number of Tracks	Total Width TL		15°	30°	45°	60°	75°	90°
	mm	inches						
1	100	3.94	KMD.14.15.01.A	KMD.14.30.01.A	KMD.14.45.01.A	KMD.14.60.01.A	KMD.14.75.01.A	KMD.14.90.01.A
2	185	7.28	KMD.14.15.02.A	KMD.14.30.02.A	KMD.14.45.02.A	KMD.14.60.02.A	KMD.14.75.02.A	KMD.14.90.02.A
3	270	10.63	KMD.14.15.03.A	KMD.14.30.03.A	KMD.14.45.03.A	KMD.14.60.03.A	KMD.14.75.03.A	KMD.14.90.03.A
4	355	13.98	KMD.14.15.04.A	KMD.14.30.04.A	KMD.14.45.04.A	KMD.14.60.04.A	KMD.14.75.04.A	KMD.14.90.04.A
5	440	17.32	KMD.14.15.05.A	KMD.14.30.05.A	KMD.14.45.05.A	KMD.14.60.05.A	KMD.14.75.05.A	KMD.14.90.05.A
6	525	20.67	KMD.14.15.06.A	KMD.14.30.06.A	KMD.14.45.06.A	KMD.14.60.06.A	KMD.14.75.06.A	KMD.14.90.06.A
7	610	24.02	KMD.14.15.07.A	KMD.14.30.07.A	KMD.14.45.07.A	KMD.14.60.07.A	KMD.14.75.07.A	KMD.14.90.07.A
8	695	27.36	KMD.14.15.08.A	KMD.14.30.08.A	KMD.14.45.08.A	KMD.14.60.08.A	KMD.14.75.08.A	KMD.14.90.08.A

Magnetic Corner Tracks



K27

Magnetic Corner Tracks for Chain Series: K450

The chains are retained in the system by a magnetic field created by magnets that are located within the track material. This design offers the user greater flexibility and improved efficiency by allowing easy removal of the chains from the curve for cleaning and maintenance purposes.

Radius: 610 mm, 24 inches



Tracks are available in four combinations of material. See page 146 for more information

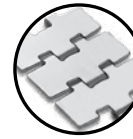

Compatible with the following steel chains:
SSE 881 M K450 / 10201



Tracks can be supplied with M8 or M10 threaded brass inserts (drawing required).

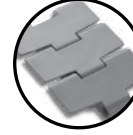

Compatible with the following plastic chains:
LF 880 M K450 / 11380M
LF 879 M K450 / 11396M
XPG 880 M K450 / 11501MG
XPG 879 M K450 / 11398MG
NG 880 M K450 / 11197M
NG 879 M K450 / 11421M

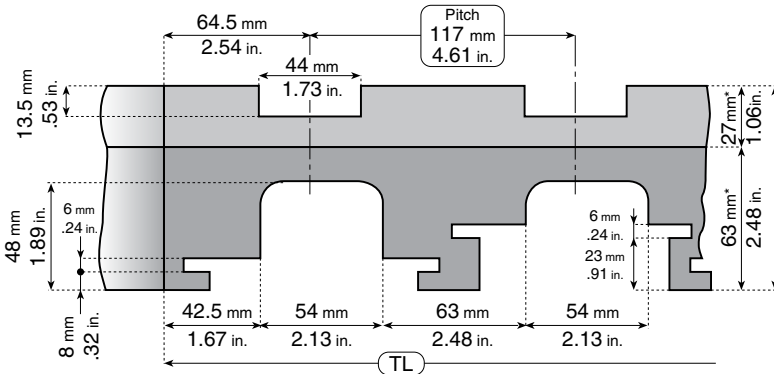

MULTI TRACKS

*Tolerance on 27mm and 63mm is $\pm 0.35\text{mm}$ or $0.015"$.

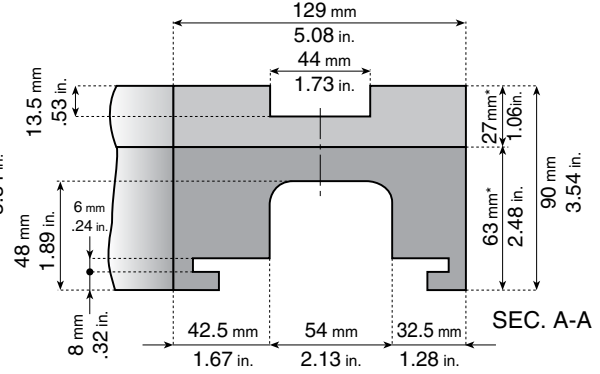

ONE TRACK

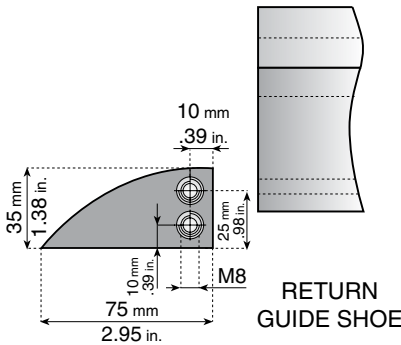

RETURN GUIDE SHOE

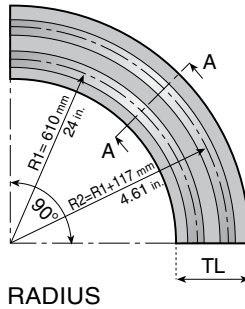

RADIUS

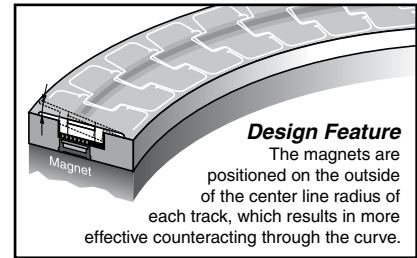

Design Feature
The magnets are positioned on the outside of the center line radius of each track, which results in more effective counteracting through the curve.

Standard
Part no. in table

Nolu-S
Add NS to part no.
(KMD.14.90.01.ANS)

Nolu-SR
Add SR to part no.
(KMD.14.90.01.ASR)

All Nolu-S
Add 2NS to part no.
(KMD.14.90.01.A2NS)

Number of Tracks	Total Width TL		15°	30°	45°	60°	75°	90°
	mm	inches						
1	129	5.08	KMD.23.15.01.A	KMD.23.30.01.A	KMD.23.45.01.A	KMD.23.60.01.A	KMD.23.75.01.A	KMD.23.90.01.A
2	246	9.69	KMD.23.15.02.A	KMD.23.30.02.A	KMD.23.45.02.A	KMD.23.60.02.A	KMD.23.75.02.A	KMD.23.90.02.A
3	363	14.29	KMD.23.15.03.A	KMD.23.30.03.A	KMD.23.45.03.A	KMD.23.60.03.A	KMD.23.75.03.A	KMD.23.90.03.A
4	480	18.90	KMD.23.15.04.A	KMD.23.30.04.A	KMD.23.45.04.A	KMD.23.60.04.A	KMD.23.75.04.A	KMD.23.90.04.A
5	597	23.50	KMD.23.15.05.A	KMD.23.30.05.A	KMD.23.45.05.A	KMD.23.60.05.A	KMD.23.75.05.A	KMD.23.90.05.A
6	714	28.11	KMD.23.15.06.A	KMD.23.30.06.A	KMD.23.45.06.A	KMD.23.60.06.A	KMD.23.75.06.A	KMD.23.90.06.A
7	831	32.72	KMD.23.15.07.A	KMD.23.30.07.A	KMD.23.45.07.A	KMD.23.60.07.A	KMD.23.75.07.A	KMD.23.90.07.A
8	948	37.32	KMD.23.15.08.A	KMD.23.30.08.A	KMD.23.45.08.A	KMD.23.60.08.A	KMD.23.75.08.A	KMD.23.90.08.A



K61

Magnetic Corner Tracks for Chain Series: K750

The chains are retained in the system by a magnetic field created by magnets that are located within the track material. This design offers the user greater flexibility and improved efficiency by allowing easy removal of the chains from the curve for cleaning and maintenance purposes.

Radius: 610 mm, 24 inches



Tracks are available in four combinations of material. See page 146 for more information



Compatible with the following steel chains:
SSE 881 M K750 / 10203



Tracks can be supplied with M8 or M10 threaded brass inserts (drawing required).

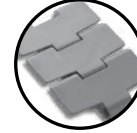

Compatible with the following plastic chains:
LF 880 M K750 / 11393M
XPG 880 M K750 / 11394MG
NG 880 M K750 / 11420M

Sprockets, Wear Strips, Chain Guides

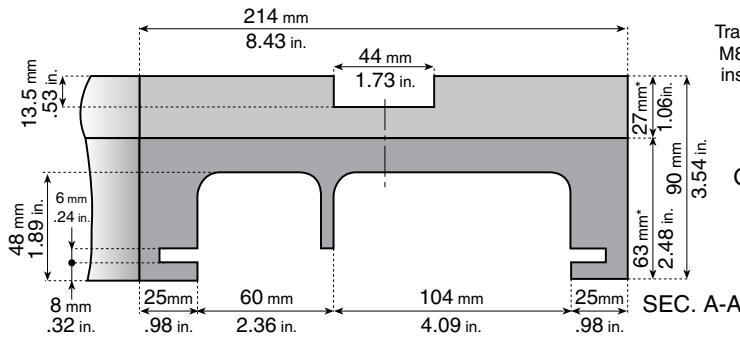

*Tolerance on 27mm and 63mm is $\pm 0.35\text{mm}$ or $0.015"$.

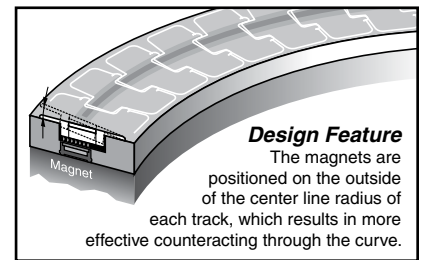
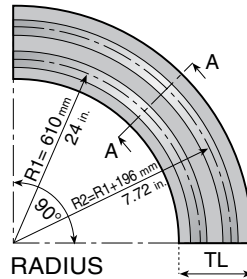
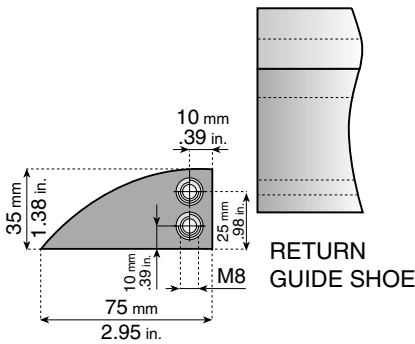
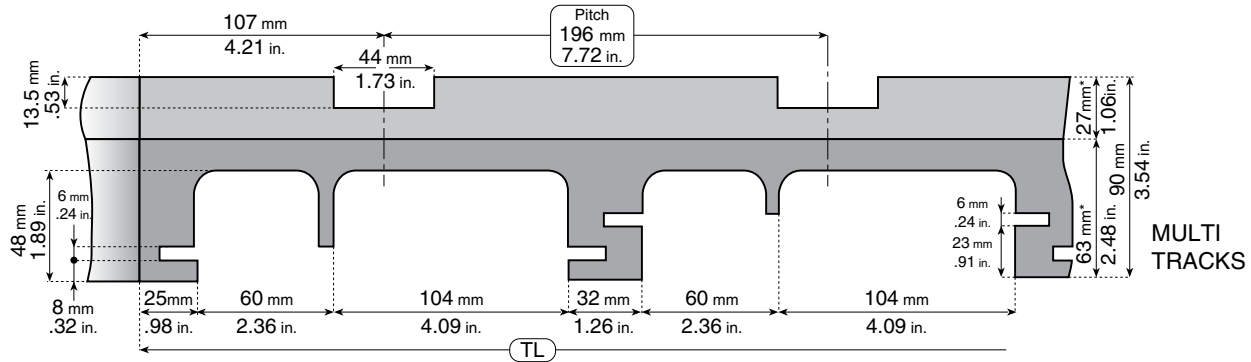

Standard
Part no. in table

Nolu-S
Add NS to part no.
(KMD.14.90.01.ANS)

Nolu-SR
Add SR to part no.
(KMD.14.90.01.ASR)

All Nolu-S
Add 2NS to part no.
(KMD.14.90.01.A2NS)

Number of Tracks	Total Width TL		15°	30°	45°	60°	75°	90°
	mm	inches						
1	214	8.43	KMD.31.15.01.A	KMD.31.30.01.A	KMD.31.45.01.A	KMD.31.60.01.A	KMD.31.75.01.A	KMD.31.90.01.A
2	410	16.14	KMD.31.15.02.A	KMD.31.30.02.A	KMD.31.45.02.A	KMD.31.60.02.A	KMD.31.75.02.A	KMD.31.90.02.A
3	606	23.86	KMD.31.15.03.A	KMD.31.30.03.A	KMD.31.45.03.A	KMD.31.60.03.A	KMD.31.75.03.A	KMD.31.90.03.A

Magnetic Corner Tracks



KB14

Magnetic Corner Tracks for Chain Series: K330

The chains are retained in the system by a magnetic field created by magnets that are located within the track material. This design offers the user greater flexibility and improved efficiency by allowing easy removal of the chains from the curve for cleaning and maintenance purposes.

Radius: 610 mm, 24 inches



Tracks are available in four combinations of material. See page 146 for more information



Compatible with the following side flexing chain belts:
LFG 2250 M K330 FT / 11320
XPG 2250 M K330 FT / 11320XPG
LFG 2260 M K330 FT / 11329
XPG 2260 M K330 FT / 11329XPG



Tracks can be supplied with M8 or M10 threaded brass inserts (drawing required).

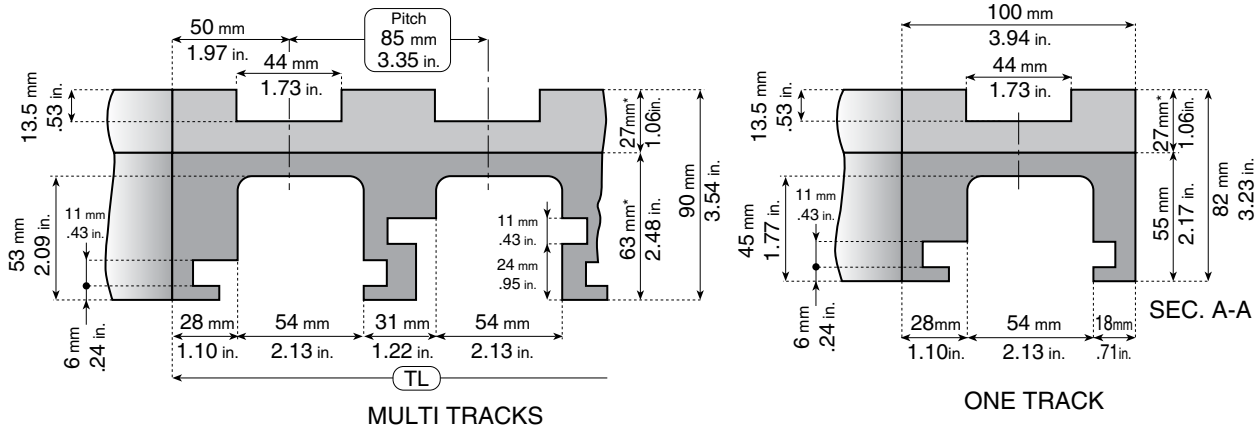

*Tolerance on 27mm and 63mm is $\pm 0.35\text{mm}$ or $0.015"$.

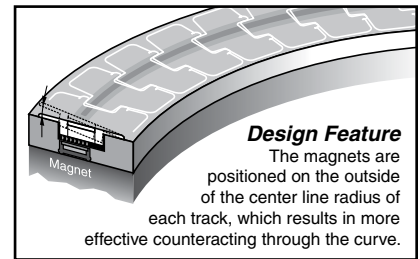
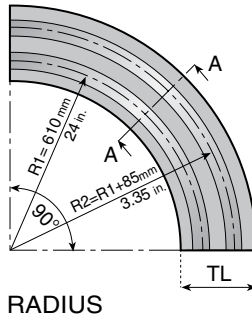
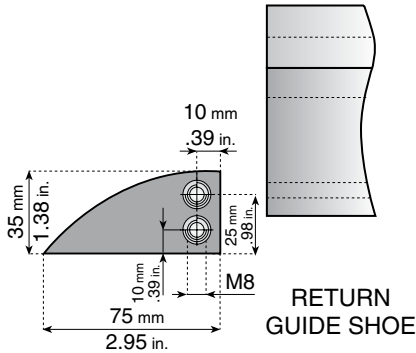

Standard
Part no. in table



Nolu-S
Add NS to part no.
(KMD.14.90.01.ANS)



Nolu-SR
Add SR to part no.
(KMD.14.90.01.ASR)



All Nolu-S
Add 2NS to part no.
(KMD.14.90.01.A2NS)

Number of Tracks	Total Width TL		15°	30°	45°	60°	75°	90°
	mm	inches						
1	100	3.94	KMD.15.15.01.A	KMD.15.30.01.A	KMD.15.45.01.A	KMD.15.60.01.A	KMD.15.75.01.A	KMD.15.90.01.A
2	185	7.28	KMD.15.15.02.A	KMD.15.30.02.A	KMD.15.45.02.A	KMD.15.60.02.A	KMD.15.75.02.A	KMD.15.90.02.A
3	270	10.63	KMD.15.15.03.A	KMD.15.30.03.A	KMD.15.45.03.A	KMD.15.60.03.A	KMD.15.75.03.A	KMD.15.90.03.A
4	355	13.98	KMD.15.15.04.A	KMD.15.30.04.A	KMD.15.45.04.A	KMD.15.60.04.A	KMD.15.75.04.A	KMD.15.90.04.A
5	440	17.32	KMD.15.15.05.A	KMD.15.30.05.A	KMD.15.45.05.A	KMD.15.60.05.A	KMD.15.75.05.A	KMD.15.90.05.A
6	525	20.67	KMD.15.15.06.A	KMD.15.30.06.A	KMD.15.45.06.A	KMD.15.60.06.A	KMD.15.75.06.A	KMD.15.90.06.A
7	610	24.02	KMD.15.15.07.A	KMD.15.30.07.A	KMD.15.45.07.A	KMD.15.60.07.A	KMD.15.75.07.A	KMD.15.90.07.A
8	695	27.36	KMD.15.15.08.A	KMD.15.30.08.A	KMD.15.45.08.A	KMD.15.60.08.A	KMD.15.75.08.A	KMD.15.90.08.A



KB27

Magnetic Corner Tracks for Chain Series: K450

The chains are retained in the system by a magnetic field created by magnets that are located within the track material. This design offers the user greater flexibility and improved efficiency by allowing easy removal of the chains from the curve for cleaning and maintenance purposes.

Radius: 610 mm, 24 inches



Tracks are available in four combinations of material. See page 146 for more information



Compatible with the following side flexing chain belts:
LFG 2250 M K450 FT / 11327
XPG 2250 M K450 FT / 11327XPG



Tracks can be supplied with M8 or M10 threaded brass inserts (drawing required).

Sprockets, Wear Strips, Chain Guides

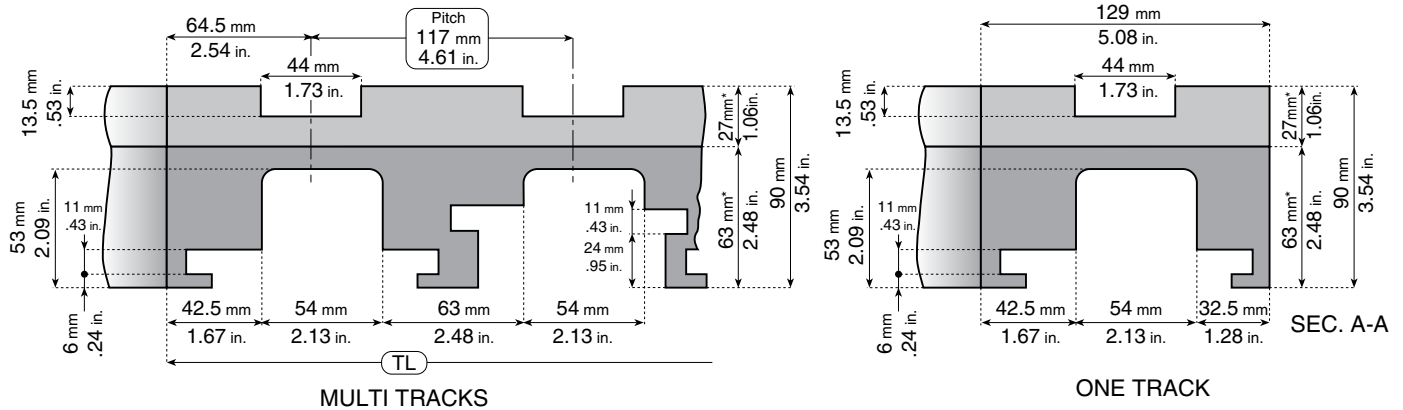

*Tolerance on 27mm and 63mm is ±0.35mm or 0.015".

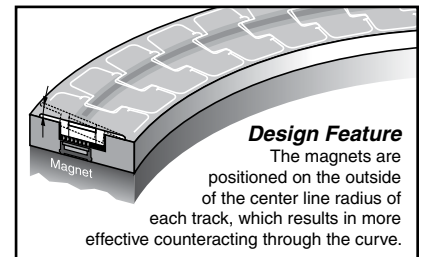
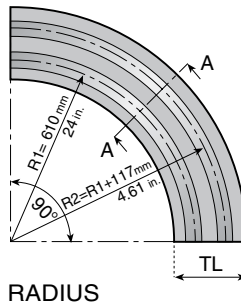
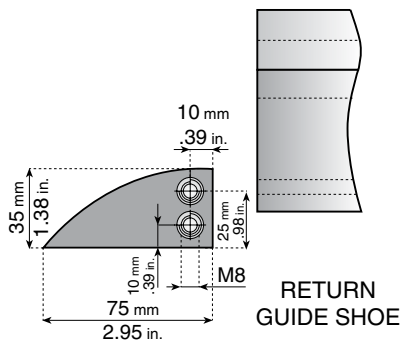

Standard
Part no. in table

Nolu-S
Add **NS** to part no.
(KMD.14.90.01.ANS)

Nolu-SR
Add **SR** to part no.
(KMD.14.90.01.ASR)

All Nolu-S
Add **2NS** to part no.
(KMD.14.90.01.A2NS)

Number of Tracks	Total Width TL		15°	30°	45°	60°	75°	90°
	mm	inches						
1	129	5.08	KMD.56.15.01.A	KMD.56.30.01.A	KMD.56.45.01.A	KMD.56.60.01.A	KMD.56.75.01.A	KMD.56.90.01.A
2	246	9.69	KMD.56.15.02.A	KMD.56.30.02.A	KMD.56.45.02.A	KMD.56.60.02.A	KMD.56.75.02.A	KMD.56.90.02.A
3	363	14.29	KMD.56.15.03.A	KMD.56.30.03.A	KMD.56.45.03.A	KMD.56.60.03.A	KMD.56.75.03.A	KMD.56.90.03.A
4	480	18.90	KMD.56.15.04.A	KMD.56.30.04.A	KMD.56.45.04.A	KMD.56.60.04.A	KMD.56.75.04.A	KMD.56.90.04.A

Magnetic Corner Tracks



KC14



Compatible with the following side flexing chain belts:
LFG 2251 M K330 FT / 11322
XPG 2251 M K330 FT / 11322XPG

Magnetic Corner Tracks for Chain Series: K330

The chains are retained in the system by a magnetic field created by magnets that are located within the track material. This design offers the user greater flexibility and improved efficiency by allowing easy removal of the chains from the curve for cleaning and maintenance purposes.

Tracks are available in four combinations of material. See page 146 for more information



Tracks can be supplied with M8 or M10 threaded brass inserts (drawing required).

Radius: 610 mm, 24 inches

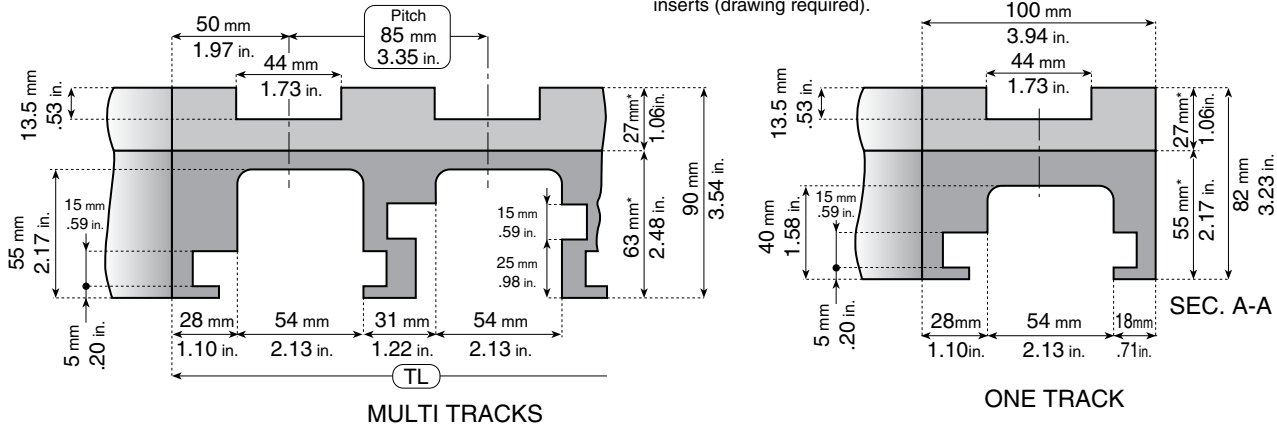

*Tolerance on 27mm and 63mm is ±0.35mm or 0.015".

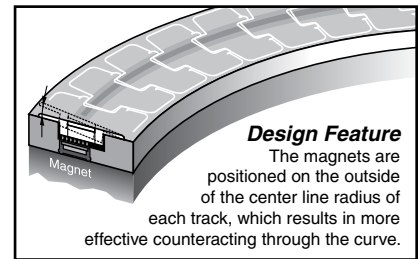
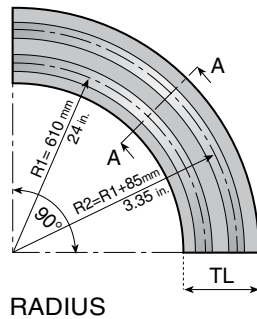
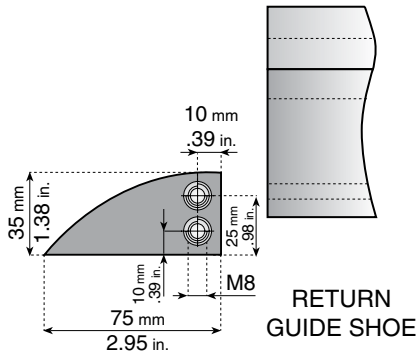

Standard
Part no. in table

Nolu-S
Add NS to part no.
(KMD.14.90.01.ANS)

Nolu-SR
Add SR to part no.
(KMD.14.90.01.ASR)

All Nolu-S
Add 2NS to part no.
(KMD.14.90.01.A2NS)

Number of Tracks	Total Width TL		15°	30°	45°	60°	75°	90°
	mm	inches						
1	100	3.94	KMD.16.15.01.A	KMD.16.30.01.A	KMD.16.45.01.A	KMD.16.60.01.A	KMD.16.75.01.A	KMD.16.90.01.A
2	185	7.28	KMD.16.15.02.A	KMD.16.30.02.A	KMD.16.45.02.A	KMD.16.60.02.A	KMD.16.75.02.A	KMD.16.90.02.A
3	270	10.63	KMD.16.15.03.A	KMD.16.30.03.A	KMD.16.45.03.A	KMD.16.60.03.A	KMD.16.75.03.A	KMD.16.90.03.A
4	355	13.98	KMD.16.15.04.A	KMD.16.30.04.A	KMD.16.45.04.A	KMD.16.60.04.A	KMD.16.75.04.A	KMD.16.90.04.A
5	440	17.32	KMD.16.15.05.A	KMD.16.30.05.A	KMD.16.45.05.A	KMD.16.60.05.A	KMD.16.75.05.A	KMD.16.90.05.A
6	525	20.67	KMD.16.15.06.A	KMD.16.30.06.A	KMD.16.45.06.A	KMD.16.60.06.A	KMD.16.75.06.A	KMD.16.90.06.A
7	610	24.02	KMD.16.15.07.A	KMD.16.30.07.A	KMD.16.45.07.A	KMD.16.60.07.A	KMD.16.75.07.A	KMD.16.90.07.A
8	695	27.36	KMD.16.15.08.A	KMD.16.30.08.A	KMD.16.45.08.A	KMD.16.60.08.A	KMD.16.75.08.A	KMD.16.90.08.A



KC27

Magnetic Corner Tracks for Chain Series: K450

The chains are retained in the system by a magnetic field created by magnets that are located within the track material. This design offers the user greater flexibility and improved efficiency by allowing easy removal of the chains from the curve for cleaning and maintenance purposes.

Radius: 610 mm, 24 inches



Tracks are available in four combinations of material. See page 146 for more information



Compatible with the following side flexing chain belts:
LFG 2251 M K450 FT / 11328
XPG 2251 M K450 FT / 11328XPG



Tracks can be supplied with M8 or M10 threaded brass inserts (drawing required).

Sprockets, Wear Strips, Chain Guides

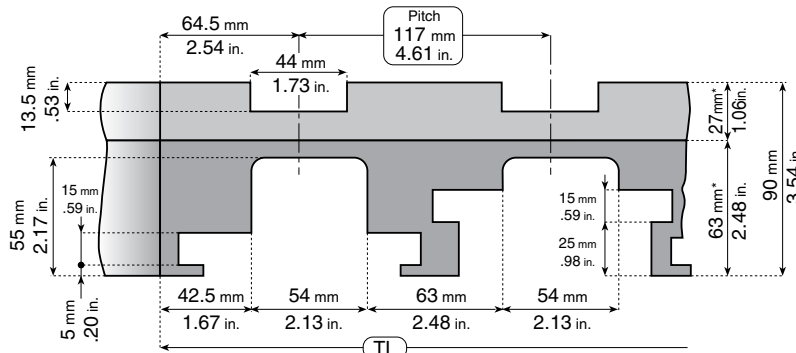

MULTI TRACKS

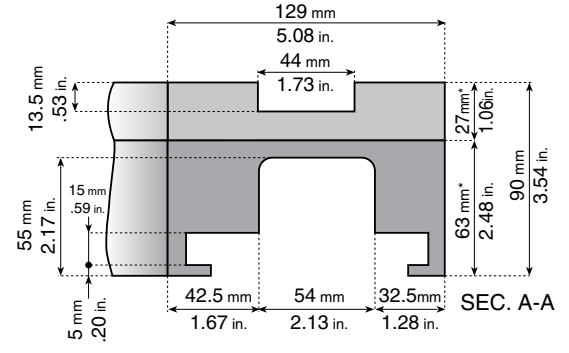

ONE TRACK

*Tolerance on 27mm and 63mm is ±0.35mm or 0.015".

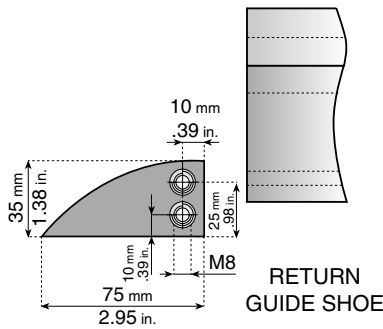

RETURN GUIDE SHOE

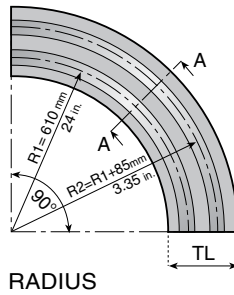

RADIUS

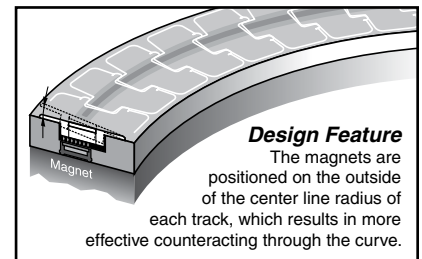

Design Feature
The magnets are positioned on the outside of the center line radius of each track, which results in more effective counteracting through the curve.

Standard
Part no. in table

Nolu-S
Add **NS** to part no.
(KMD.14.90.01.ANS)

Nolu-SR
Add **SR** to part no.
(KMD.14.90.01.ASR)

All Nolu-S
Add **2NS** to part no.
(KMD.14.90.01.A2NS)

Number of Tracks	Total Width TL		15°	30°	45°	60°	75°	90°
	mm	inches						
1	129	5.08	KMD.66.15.01.A	KMD.66.30.01.A	KMD.66.45.01.A	KMD.66.60.01.A	KMD.66.75.01.A	KMD.66.90.01.A
2	246	9.69	KMD.66.15.02.A	KMD.66.30.02.A	KMD.66.45.02.A	KMD.66.60.02.A	KMD.66.75.02.A	KMD.66.90.02.A
3	363	14.29	KMD.66.15.03.A	KMD.66.30.03.A	KMD.66.45.03.A	KMD.66.60.03.A	KMD.66.75.03.A	KMD.66.90.03.A
4	480	18.90	KMD.66.15.04.A	KMD.66.30.04.A	KMD.66.45.04.A	KMD.66.60.04.A	KMD.66.75.04.A	KMD.66.90.04.A



Safe Transfer Modules

Sprockets, Wear Strips, Chain Guides



Features:

- Safe and smooth transfer of instable products
- Compact Design
- One solid piece, no edges
- Easy installation



INSERTS

The Safe Transfer Module can be supplied with M8 or M10 brass inserts to your detailed drawing.



SPECIAL DIMENSIONS

On request, Safe Transfer Module with special dimensions can be produced.



TECHNICAL SUPPORT

For further information, contact our Technical support team.



Standard Version

Special Note:

- For TAB system and BEVEL system, one set can be used as left or right transfer
- For MAGNETIC system, left or right transfer has to be specified when ordering

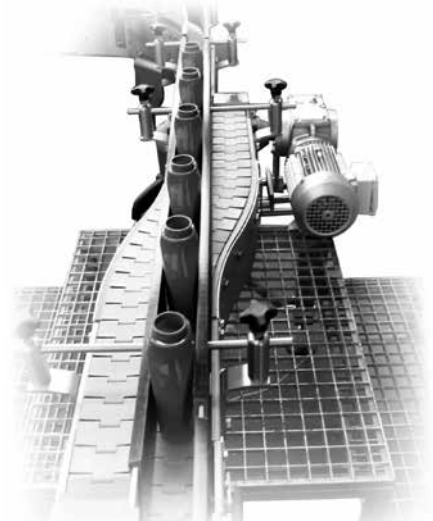

Compact Version

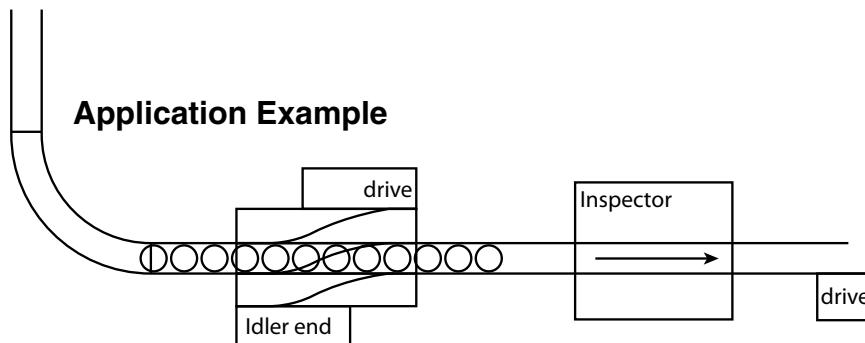

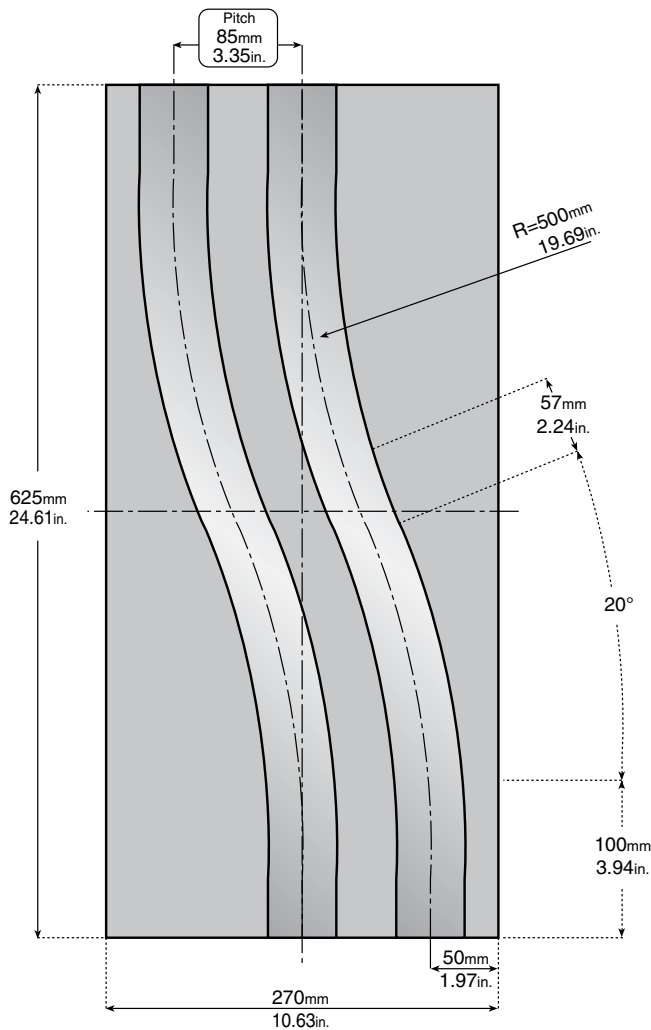
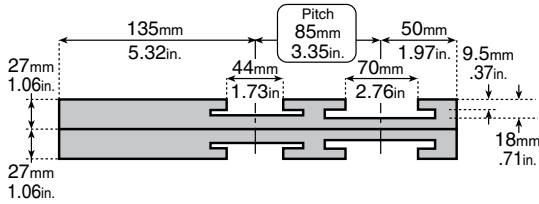
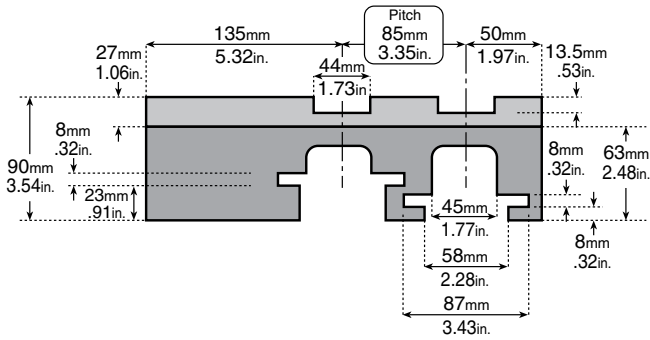

Magnetic System

Version	Left	Right
Standard	-	STMRM032002B
Compact	-	STMRM032002BC

Tab System

Version	Left/Right
Standard	STMT032002B
Compact	STMT032002BC

Sprockets, Wear Strips, Chain Guides

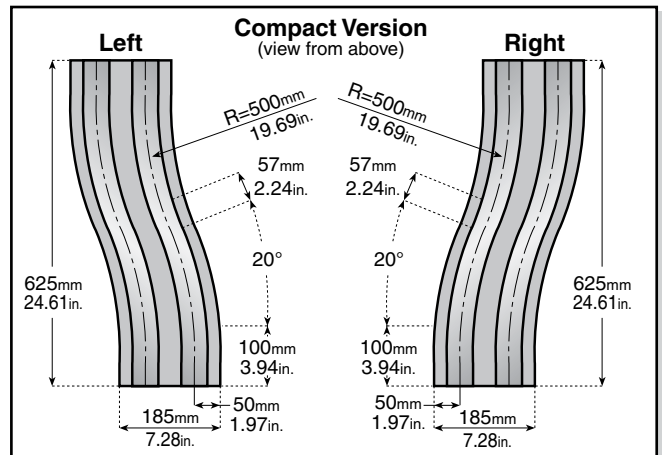
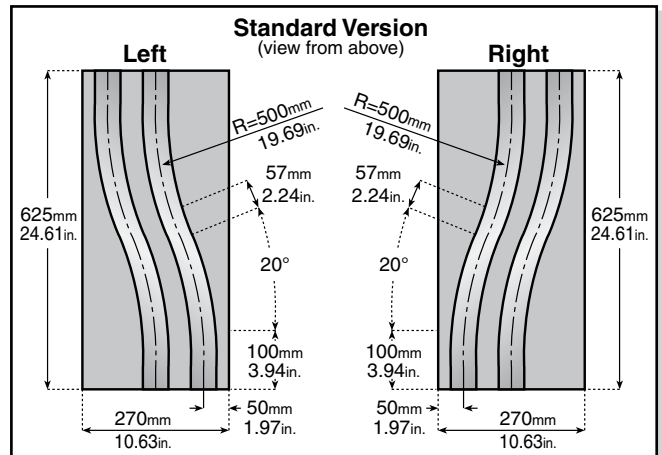



DynaPlate Modular Transfer Plates

DYNAPLATE
ROLLER TRANSFER PLATES

Perfect for use with
SYSTEM PLAST™
Chains and Belts!

DynaPlate

- Smooth transition between conveyors
- Use individually or back-to back
- Heavy duty, robust construction
- Easy, flexible mounting

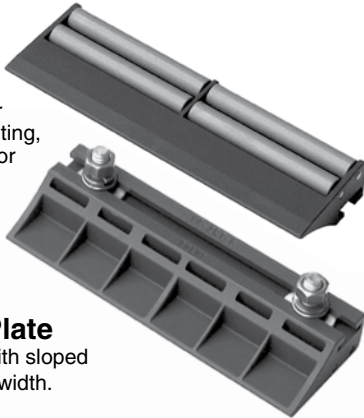

T-bolt slides for accurate mounting, but won't strip or turn during tightening.

Transfer Plate

2 roller rows with sloped entry. 6.1 inch width.

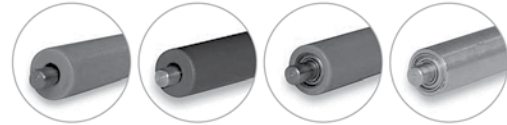
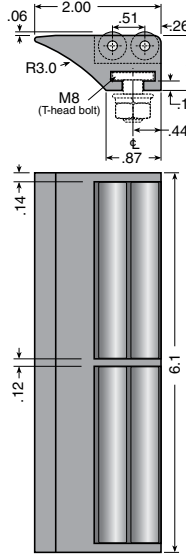

Standard

Brown acetal roller.

SR

Red low noise PBT roller.

SSA

Blue acetal roller with mini ball bearing.

SS

Stainless steel roller with mini ball bearing.

For special applications, environments, and aggressive agents, please contact the System Plast engineering department.

Material: XP acetal frame. Choice of roller types. Stainless steel pins, washers and bolts.

Part Number	Roller Type	Length (in.)
16S00020-SR	SR	6.1
16S00020-SSA	SSA	6.1

Head to tail transfer using two roller transfer assemblies positioned back-to-back.

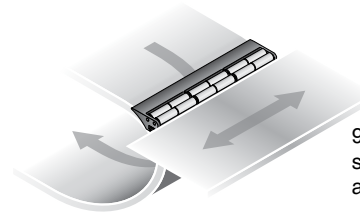
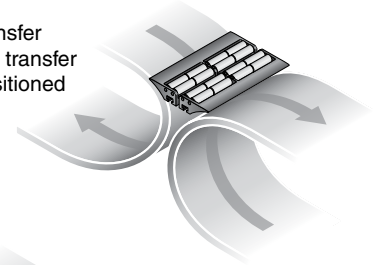

90° transfer using single roller transfer assembly.

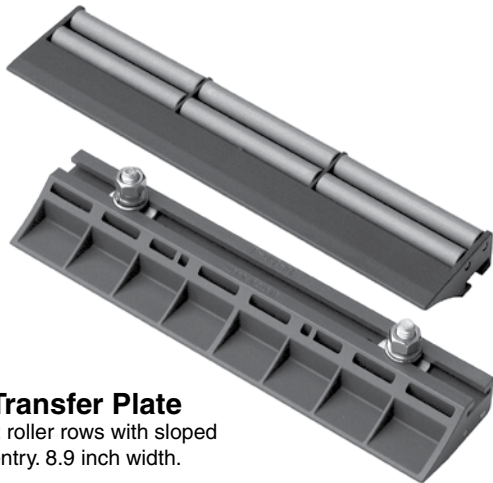

Transfer Plate

2 roller rows with sloped entry. 8.9 inch width.

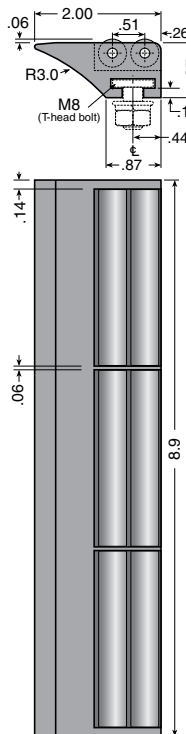

Material: XP acetal frame. Choice of roller types. Stainless steel pins, washers and bolts.

Part Number	Roller Type	Length (in.)
16S00023-SR	SR	8.9
16S00023-SSA	SSA	8.9

SYSTEM PLAST™



DynaPlate

- Smooth transition between conveyors
- Use individually or back-to back
- Heavy duty, robust construction
- Easy, flexible mounting

T-bolt slides for accurate mounting, but won't strip or turn during tightening.

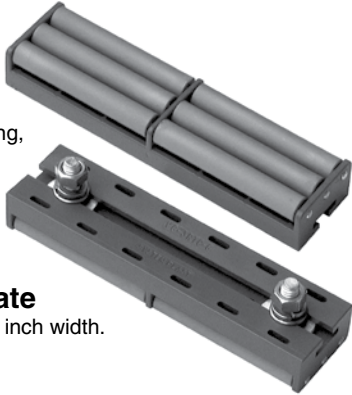

Transfer Plate
3 roller rows. 6.1 inch width.

DYNAPLATE

ROLLER TRANSFER PLATES

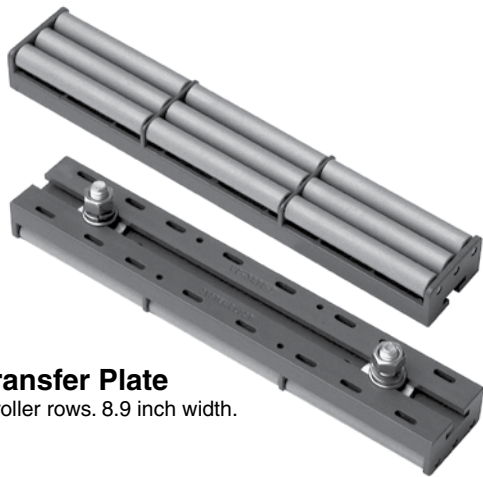
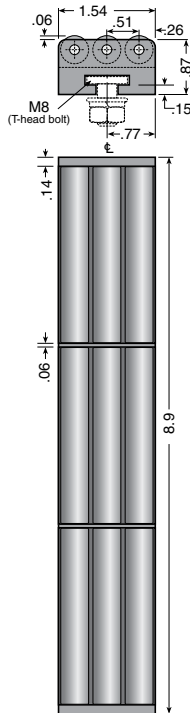
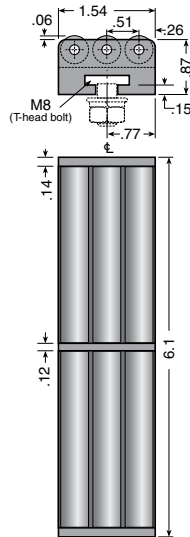

Transfer Plate
3 roller rows. 8.9 inch width.

Perfect for use with

SYSTEM PLAST™

Chains and Belts!

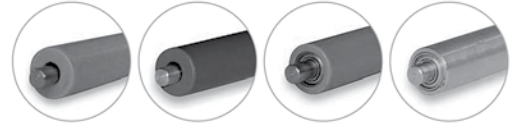

- | | | | |
|---|--|--|---|
| Standard
Brown acetal roller. | SR
Red low noise PBT roller. | SSA
Blue acetal roller with mini ball bearing. | SS
Stainless steel roller with mini ball bearing. |
|---|--|--|---|

Sprockets, Wear Strips, Chain Guides

For special applications, environments, and aggressive agents, please contact the System Plast engineering department.

Material: XP acetal frame. Choice of roller types. Stainless steel pins, washers and bolts.

Part Number	Roller Type	Length (in.)
16S00021-SR	SR	6.1
16S00021-SSA	SSA	6.1

Material: XP acetal frame. Choice of roller types. Stainless steel pins, washers and bolts.

Part Number	Roller Type	Length (in.)
16S00024-SR	SR	8.9
16S00024-SSA	SSA	8.9

DynaPlate Combinations

Mix and match for best transfer lengths and widths

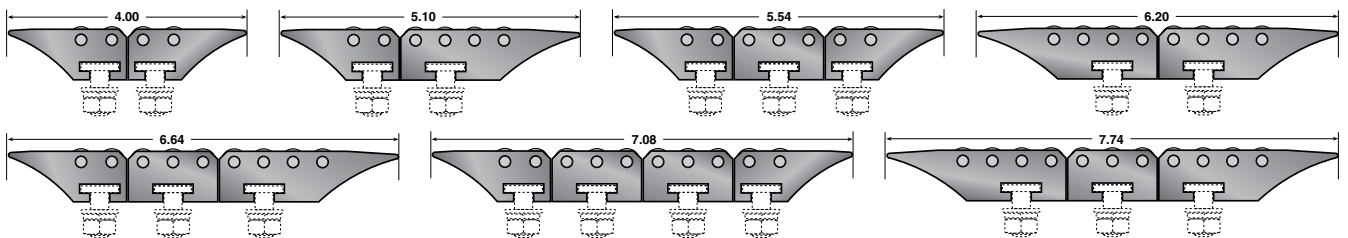



DYNAPLATE ROLLER TRANSFER PLATES

DynaPlate

- Smooth transition between conveyors
- Use individually or back-to back
- Heavy duty, robust construction
- Easy, flexible mounting

T-bolt slides for accurate mounting, but won't strip or turn during tightening.

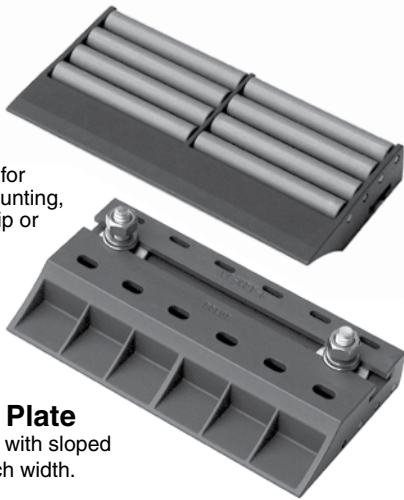

Transfer Plate

4 roller rows with sloped entry. 6.1 inch width.

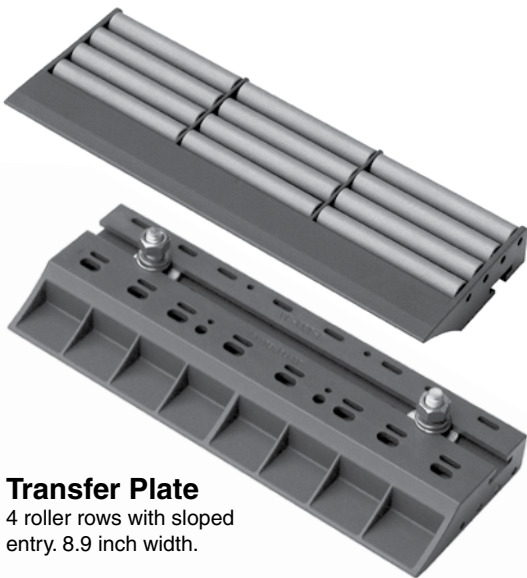
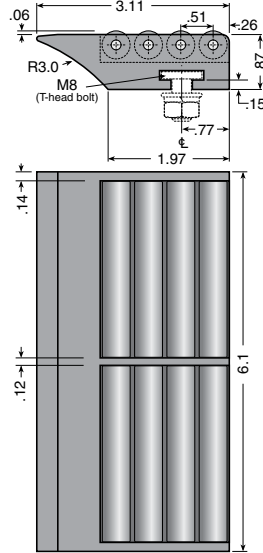

Transfer Plate

4 roller rows with sloped entry. 8.9 inch width.

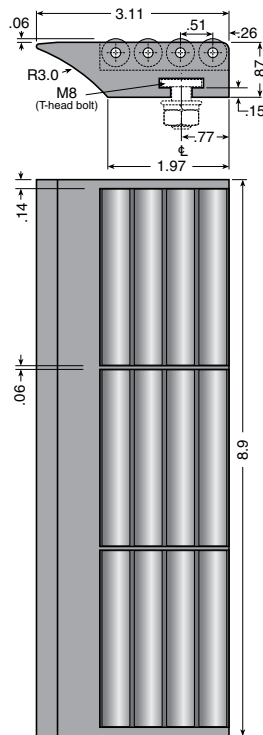

Perfect for use with SYSTEM PLAST™ Chains and Belts!

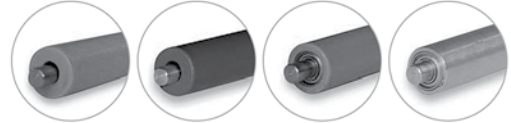

Standard

Brown acetal roller.

SR

Red low noise PBT roller.

SSA

Blue acetal roller with mini ball bearing.

SS

Stainless steel roller with mini ball bearing.

For special applications, environments, and aggressive agents, please contact the System Plast engineering department.

Material: XP acetal frame. Choice of roller types. Stainless steel pins, washers and bolts.

Part Number	Roller Type	Length (in.)
16S00022-SR	SR	6.1
16S00022-SSA	SSA	6.1



Material: XP acetal frame. Choice of roller types. Stainless steel pins, washers and bolts.

Part Number	Roller Type	Length (in.)
16S00025-SR	SR	8.9
16S00025-SSA	SSA	8.9

Modular Transfer Plates



Perfect for use with **SYSTEM PLAST™** Chains and Belts!

- Easy head to tail transfer
- Ultra low friction
- Low noise beads
- Clean design
- Back-to-back and end-to-end modularity
- Quick and easy assembly
- Mounting hardware included



Hex head bolts are included. They are retained in the frame so they will not slide when the nut is tightened.

Sprockets, Wear Strips, Chain Guides

Transfer Plate

2, 3, or 5 bead or roller rows with sloped entry. 3.35 inch width. Blue low noise multi-beads shown.

Material: XP acetal frame. Choice of multi-beads or rollers. Stainless steel pins, washers and bolts.

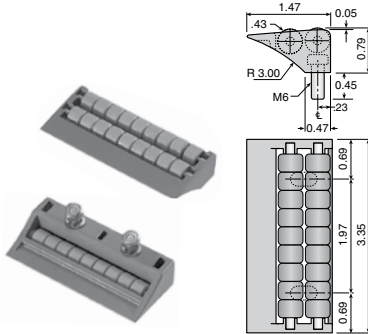

Part Number	Roller Type	Length (in.)
16777	Standard	3.35
16777-SR	SR	3.35
16777-SSA	SSA	3.35

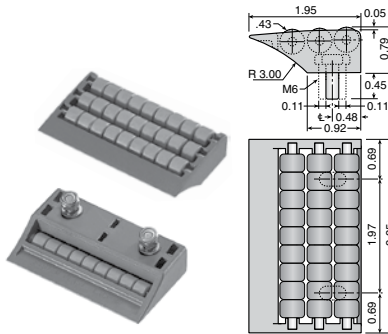

Part Number	Roller Type	Length (in.)
16770	Standard	3.35
16770-SR	SR	3.35
16770-SSA	SSA	3.35

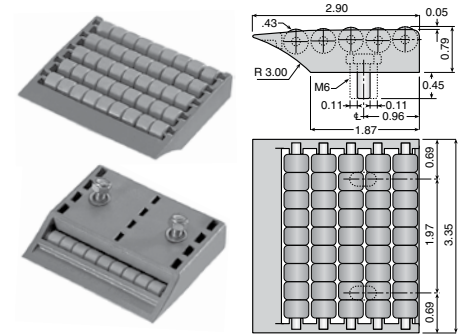

Part Number	Roller Type	Length (in.)
16772	Standard	3.35
16772-SR	SR	3.35
16772-SSA	SSA	3.35

Transfer Plate

2, 3, or 5 bead or roller rows with sloped entry. 4.53 inch width. Blue low noise multi-beads shown.

Material: XP acetal frame. Choice of multi-beads or rollers. Stainless steel pins, washers and bolts.

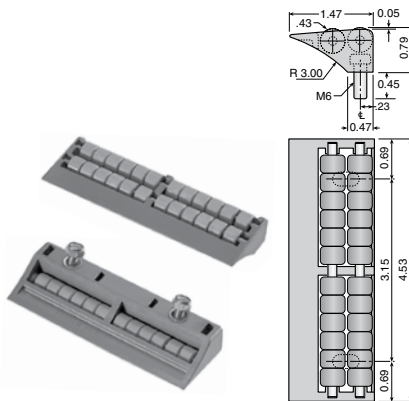

Part Number	Roller Type	Length (in.)
16778	Standard	4.53
16778-SR	SR	4.53
16778-SSA	SSA	4.53

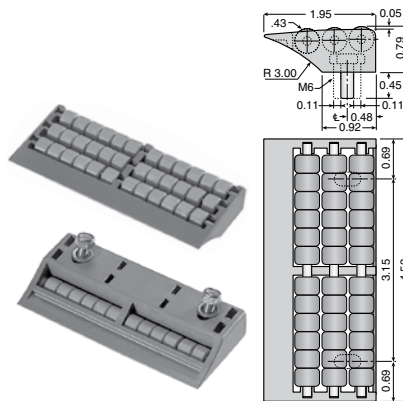

Part Number	Roller Type	Length (in.)
16771	Standard	4.53
16771-SR	SR	4.53
16771-SSA	SSA	4.53

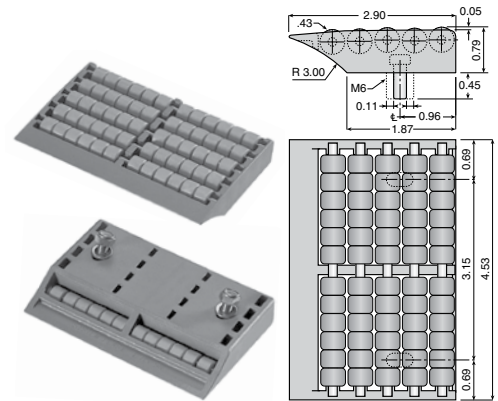

Part Number	Roller Type	Length (in.)
16773	Standard	4.53
16773-SR	SR	4.53
16773-SSA	SSA	4.53

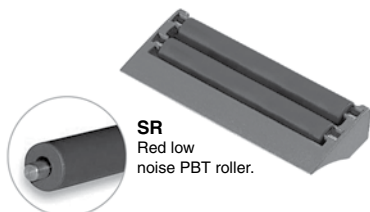

SR
Red low noise PBT roller.

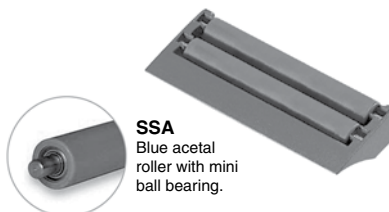

SSA
Blue acetal roller with mini ball bearing.

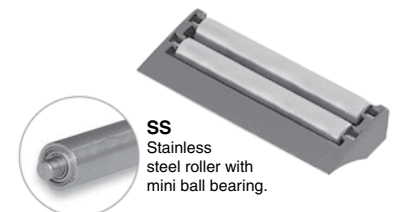

SS
Stainless steel roller with mini ball bearing.

For special applications, environments, and aggressive agents, please contact the System Plast engineering department.



Modular Transfer Plate Assemblies

Sprockets, Wear
Strips, Chain Guides

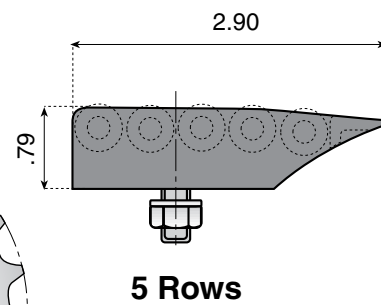
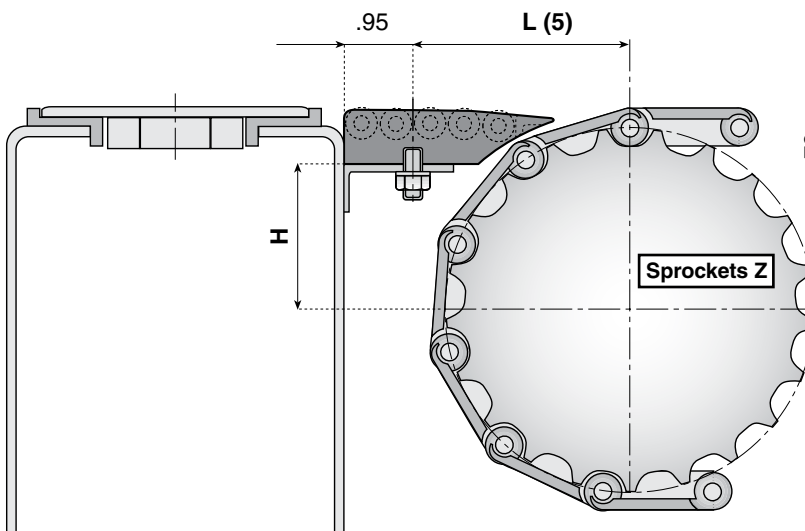
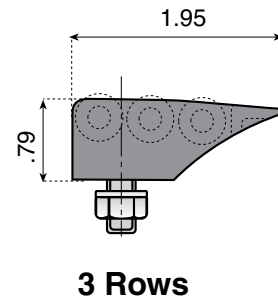
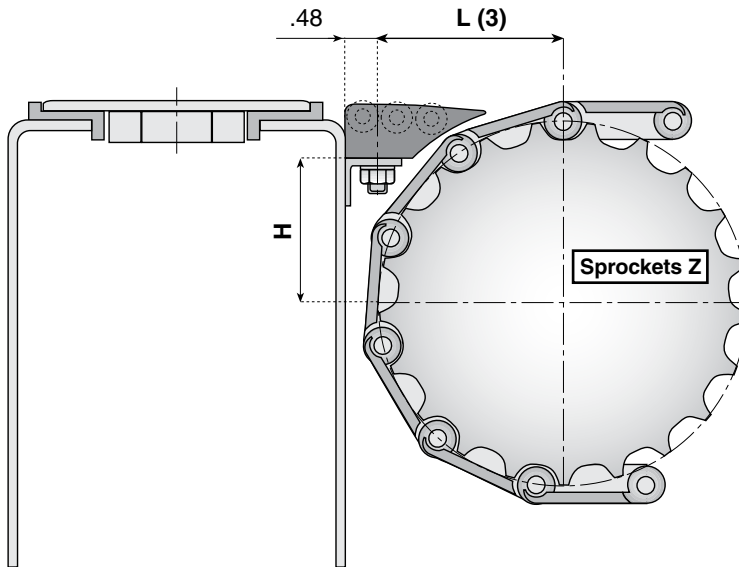
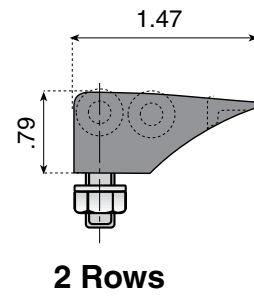
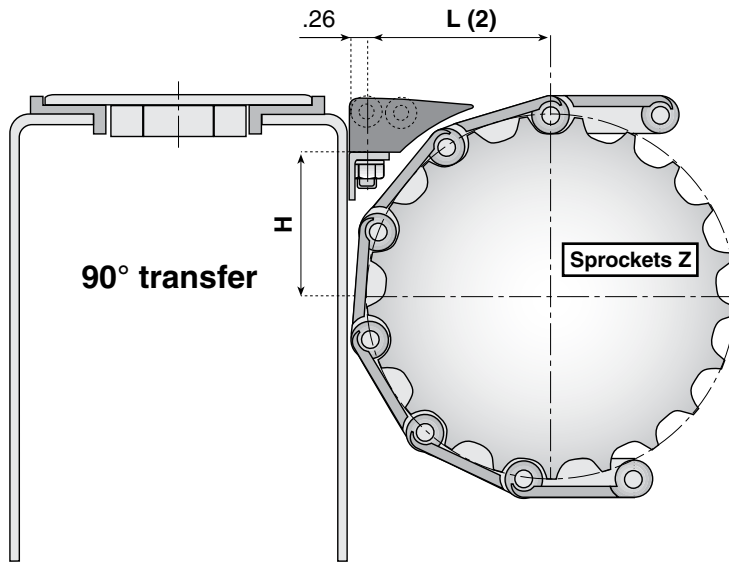

Modular Transfer Plate Assemblies



Chain Type	Sprockets Z15				Sprockets Z17				Sprockets Z19				Sprockets Z21				Sprockets Z23				Sprockets Z25				Sprockets Z27				Sprockets Z29											
	H	L(2)	L(3)	L(5)	H	L(2)	L(3)	L(5)	H	L(2)	L(3)	L(5)	H	L(2)	L(3)	L(5)	H	L(2)	L(3)	L(5)	H	L(2)	L(3)	L(5)	H	L(2)	L(3)	L(5)	H	L(2)	L(3)	L(5)	H	L(2)	L(3)	L(5)				
812-815-800-802-805-8157	1.35	2.24	2.43	2.93	1.59	2.30	2.47	2.98	1.82	2.40	2.52	3.03	2.06	2.51	2.56	3.07	2.29	2.61	2.61	3.12	2.53	2.71	2.65	3.16	2.76	2.81	2.69	3.20	3.00	2.90	2.72	3.24								
881-8810-881TAB-8810TAB-881M-881MO-8857-8857TAB	1.35	2.24	2.43	2.94	1.59	2.30	2.47	2.98	1.82	2.40	2.52	3.03	2.06	2.51	2.56	3.07	2.29	2.61	2.61	3.12	2.53	2.71	2.65	3.16	2.76	2.81	2.69	3.20	3.00	2.90	2.72	3.24								
512-515	1.92	2.44	2.54	3.05	2.23	2.59	2.59	3.10	2.51	2.72	2.65	3.16	2.87	2.85	2.70	3.21																								
1874	1.61	2.56	2.77	3.28	1.84	2.57	2.83	3.34	2.08	2.69	2.89	3.40	2.35	2.80	2.94	3.45	2.56	2.90	2.99	3.50	2.80	3.00	3.04	3.56																
820-SK38	1.38	2.27	2.46	2.97	1.61	2.33	2.51	3.02	1.85	2.43	2.56	3.07	2.08	2.54	2.60	3.11	2.31	2.64	2.64	3.15	2.55	2.74	2.69	3.20	2.97	2.65	2.72	3.24	3.02	2.93	2.76	3.28								
831	1.41	2.27	2.46	2.97	1.64	2.33	2.51	3.02	1.88	2.43	2.56	3.07	2.11	2.54	2.60	3.11	2.35	2.64	2.64	3.15	2.58	2.74	2.69	3.20	3.00	2.65	2.72	3.24	3.06	2.93	2.76	3.28								
821	1.41	2.29	2.47	2.98	1.64	2.34	2.52	3.04	1.88	2.45	2.57	3.08	2.11	2.56	2.61	3.13	2.35	2.66	2.66	3.17	2.58	2.76	2.70	3.21	3.00	2.85	2.74	3.26	3.06	2.94	2.78	3.30								
843	0.81	2.26	2.48	2.99	0.97	2.31	2.52	3.04	1.13	2.36	2.57	3.08	1.29	2.41	2.61	3.12	1.45	2.45	2.65	3.16	1.59	2.49	2.69	3.20																
863	1.61	2.57	2.78	3.29	1.84	2.58	2.83	3.35	2.08	2.69	2.89	3.41	2.32	2.80	2.95	3.46	2.56	2.91	3.00	3.51	2.80	3.01	3.05	3.56																
1843	0.84	2.19	2.40	2.91	1.00	2.24	2.44	2.95	1.16	2.28	2.48	2.99	1.32	2.32	2.52	3.03	1.48	2.36	2.56	3.07	1.64	2.40	2.59	3.10																
1873	1.62	2.39	2.59	3.10	1.85	2.47	2.64	3.15	2.11	2.58	2.69	3.20	2.33	2.69	2.73	3.24	2.57	2.79	2.78	3.29	2.81	2.88	2.82	3.33																
815VG-805VG-815VG(rubber)	1.47	2.26	2.44	2.96	1.70	2.31	2.49	3.00	1.94	2.42	2.54	3.05	2.17	2.53	2.58	3.09	2.41	2.63	2.63	3.14	2.65	2.73	2.67	3.18	2.88	2.82	2.70	3.22	3.12	2.91	2.74	3.26								
831VG-821VG-	1.53	2.26	2.44	2.96	1.76	2.31	2.50	3.01	2.00	2.42	2.54	3.06	2.23	2.53	2.59	3.10	2.46	2.63	2.63	3.15	2.70	2.73	2.67	3.19	3.12	2.82	2.72	3.23	3.17	2.92	2.76	3.27								
1873VG	1.77	2.33	2.50	3.01	2.00	2.47	2.55	3.06	2.24	2.57	2.59	3.10	2.48	2.67	2.61	3.12	2.72	2.77	2.67	3.18	2.96	2.87	2.71	3.22	3.19	2.96	2.75	3.26												
LPB 831	1.98	2.47	2.53	3.04	2.21	2.57	2.57	3.09	2.45	2.67	2.61	3.13	2.68	2.77	2.66	3.17	2.92	2.86	2.69	3.20	3.15	2.95	2.73	3.24																
LPB 821	1.98	2.48	2.55	3.06	2.21	2.59	2.59	3.10	2.45	2.69	2.63	3.14	2.68	2.78	2.67	3.19	2.92	2.87	2.71	3.22	3.15	2.96	2.75	3.26																

Sprockets, Wear Strips, Chain Guides

Chain Type	Sprockets Z9				Sprockets Z10				Sprockets Z11				Sprockets Z12				Sprockets Z13				Sprockets Z14				Sprockets Z15											
	H	L(2)	L(3)	L(5)	H	L(2)	L(3)	L(5)	H	L(2)	L(3)	L(5)	H	L(2)	L(3)	L(5)	H	L(2)	L(3)	L(5)	H	L(2)	L(3)	L(5)	H	L(2)	L(3)	L(5)	H	L(2)	L(3)	L(5)				
8257VG	1.82	2.40	2.52	3.03	2.05	2.51	2.56	3.07	2.29	2.61	2.60	3.11	2.52	2.71	2.65	3.16																				
LPB 8257	2.39	2.65	2.62	3.13	2.62	2.75	2.66	3.17	2.86	2.84	2.70	3.21	3.09	2.93	2.74	3.25																				
878TAB-879-879TAB-879M-880-880TAB-880M	1.74	2.33	2.50	3.02	1.98	2.48	2.55	3.06	2.21	2.58	2.59	3.10	2.45	2.68	2.63	3.15	2.69	2.78	2.67	3.19	2.92	2.87	2.71	3.22	3.16	2.96	2.75	3.26								
882-882TAB-882M	1.82	2.40	2.52	3.03	2.05	2.51	2.56	3.07	2.29	2.61	2.60	3.11	2.52	2.71	2.65	3.16																				
878TAB VG-879TAB VG-879M VG	1.87	2.40	2.52	3.03	2.09	2.51	2.56	3.07	2.33	2.61	2.61	3.12	2.57	2.71	2.65	3.16	2.80	2.81	2.69	3.20	3.04	2.87	2.72	3.24												
882M VG-882TAB VG	1.94	2.45	2.53	3.04	2.17	2.55	2.57	3.09	2.41	2.65	2.62	3.13	2.64	2.75	2.66	3.17																				
LBP 878TAB-LPB 879M	2.35	2.43	2.60	3.11	2.58	2.57	2.65	3.16	2.81	2.68	2.69	3.20	3.05	2.78	2.73	3.24	3.29	2.87	2.77	3.28	3.52	2.97	2.81	3.32	3.76	3.06	2.85	3.36								
LBP 882TAB-LBP 882M	2.39	2.65	2.62	3.13	2.62	2.75	2.66	3.17	2.86	2.84	2.70	3.21	3.09	2.93	2.74	3.25																				

Belt Type	Sprockets Z12				Sprockets Z16				Sprockets Z18				Sprockets Z20				Sprockets Z21				Sprockets Z24				Sprockets Z28											
	H	L(2)	L(3)	L(5)	H	L(2)	L(3)	L(5)	H	L(2)	L(3)	L(5)	H	L(2)	L(3)	L(5)	H	L(2)	L(3)	L(5)	H	L(2)	L(3)	L(5)	H	L(2)	L(3)	L(5)	H	L(2)	L(3)	L(5)				
series 2120 FT-2121FT					0.66	2.00	2.26	2.73					0.98	2.12	2.37	2.84									1.30	2.20	2.45	2.93	1.62	2.30	2.55	3.02				
series 2120 VG					0.73	2.01	2.26	2.74					1.06	2.13	2.38	2.85									1.37	2.21	2.46	2.93	1.70	2.30	2.56	3.03				
series 2120 LBP					1.17	2.02	2.28	2.75					1.49	2.14	2.39	2.86									1.81	2.22	2.47	2.94	2.13	2.31	2.57	3.04				
series 2250 FT-2250 FG	1.28	2.25	2.50	2.98	1.91	2.37	2.63	3.10	2.23	2.50	2.76	3.23	2.55	2.52	2.77	3.24																				
series 2251 FT-2252 FT					1.99	2.49	2.74	3.22	2.28	2.50	2.76	3.23	2.59	2.61	2.86	3.33	2.75	2.61	2.86	3.33																
series 2251 VG					2.09	2.51	2.76	3.23	2.38	2.52	2.77	3.24	2.69	2.63	2.88	3.35	2.85	2.62	2.87	3.35																
series 2251 LBP					2.56	2.52	2.77	3.25	2.85	2.53	2.79	3.26	3.16	2.64	2.89	3.36	3.32	2.64	2.89	3.24																

Chain-Belt Type	Sprockets Z16				Sprockets Z18				Sprockets Z19			
	H	L(2)	L(3)	L(5)	H	L(2)	L(3)	L(5)	H	L(2)	L(3)	L(5)
series 2250M-FT-2250M-FG	2.16	2.61	2.87	3.34	2.47	2.76	3.01	3.48	2.67	2.90	3.15	3.62
series 2251M-FT-2251M-FG	2.31	2.68	2.93	3.41	2.63	2.81	3.06	3.54	2.83	2.92	3.17	3.65



Modular Transfer Plate Assemblies

Assemblies with two modules

Sprockets, Wear Strips, Chain Guides

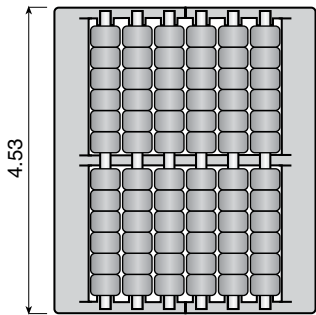
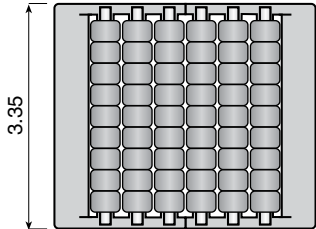
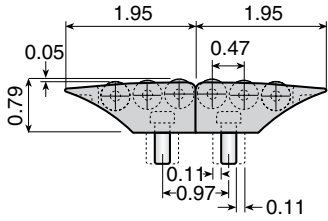

Assembly with two modules of three rows of rollers

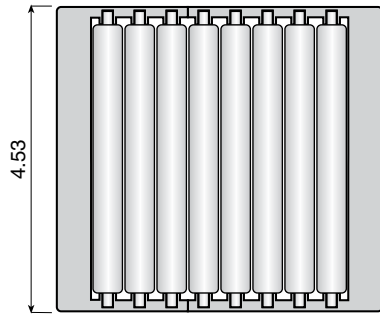
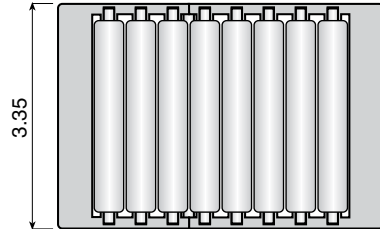
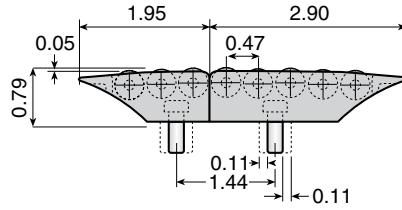

Assembly with two modules:
- One module with three rows of rollers
- One module with five rows of rollers

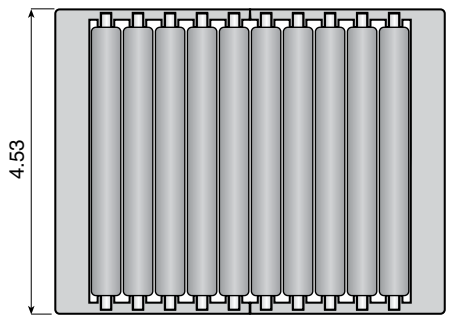
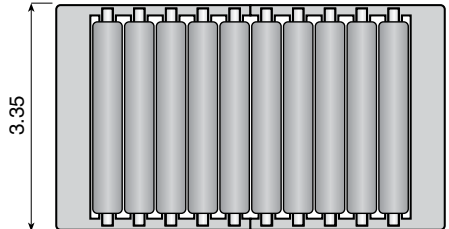
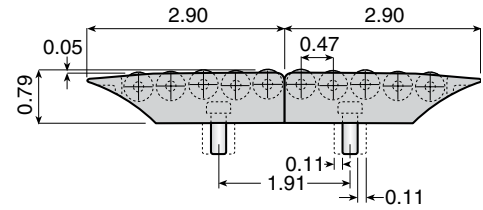

Assembly with two modules of five rows of rollers

Assemblies with head to tail transfers

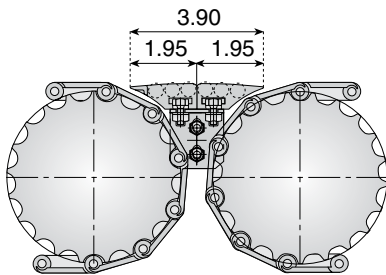

Head to tail transfer with two modules of three rows of rollers.

Assembly with stainless steel or plastic flat top chains. Top plate thickness from 0.12 inch. to 0.19 inch.

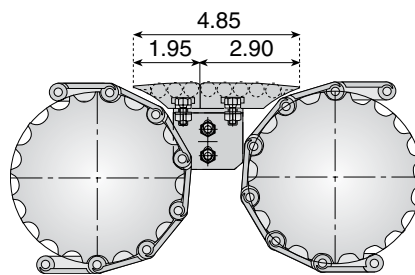

Head to tail transfer two with modules:
- One module of three rows of rollers
- One module of five rows of rollers

Assembly with stainless steel or plastic flat top chains. Top plate thickness from 0.12 inch. to 0.19 inch.

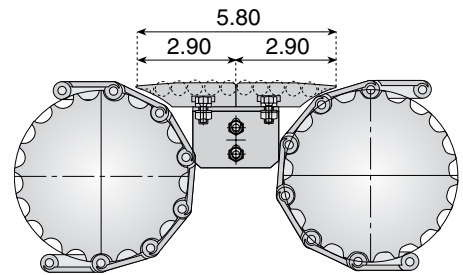

Head to tail transfer with two modules of five rows of rollers.

Assembly with stainless steel or plastic flat top chains. Top plate thickness from 0.12 inch. to 0.19 inch.

See pages 160-161 for transfer plate mounting dimensions.

Typical Valu Guide Component Applications

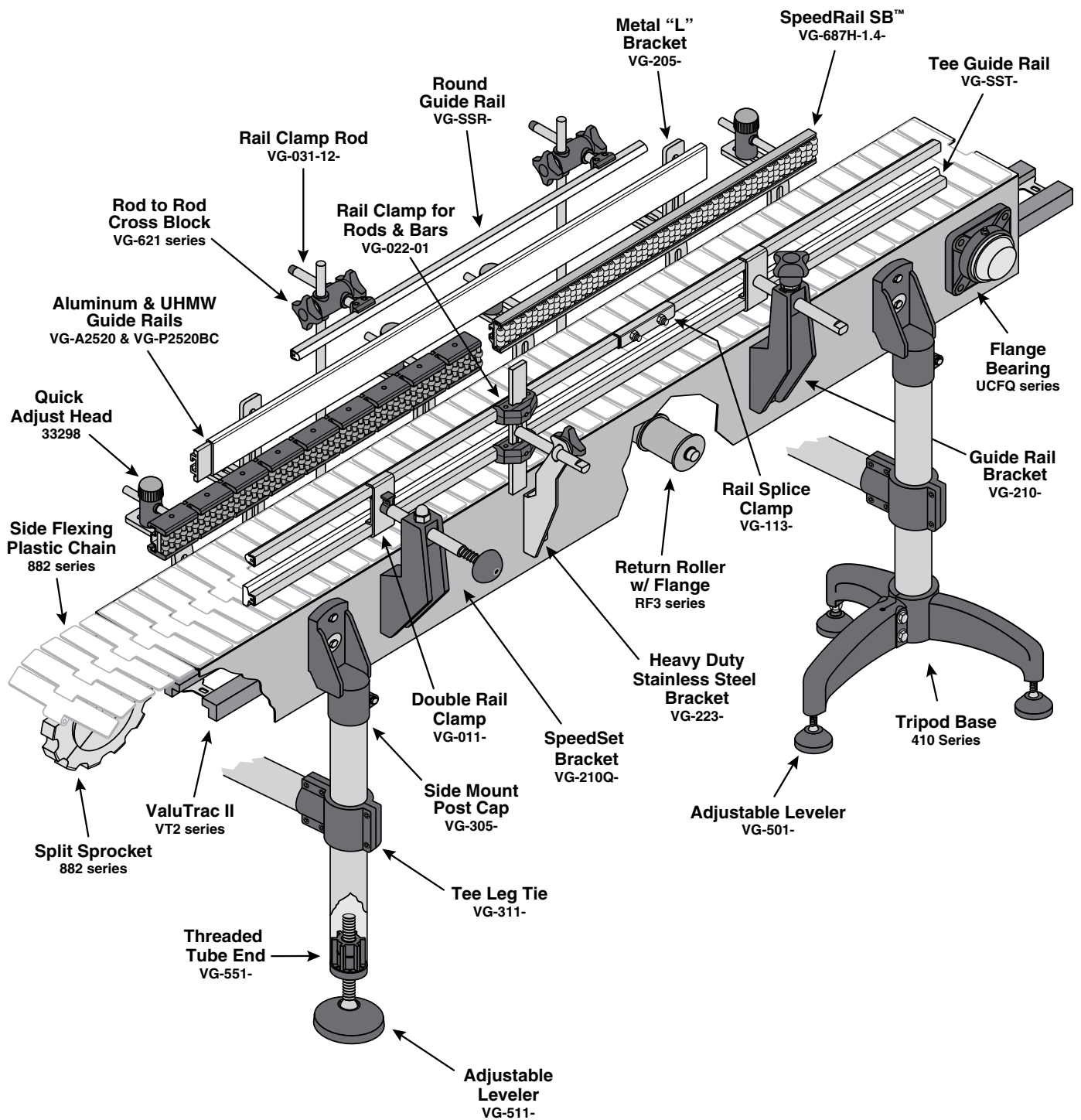

Sprockets, Wear Strips, Chain Guides



Return Rollers

The Next Generation of conveyor chain return rollers!

- Sanitary, watertight, sealed
- Excellent wear and chemical resistance
- Low noise, low friction

Our conveyor chain return rollers are made from impact resistant material. They are highly resistant to chemicals and have self lubricating characteristics. A urethane sleeve or ribbed rubber cover option is available for better traction, low noise, and long service life. Other options include a completely solid version, plus side flanges for each type of roller.

Sprockets, Wear Strips, Chain Guides

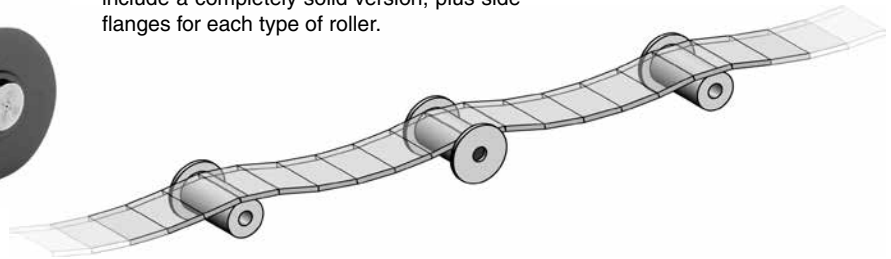
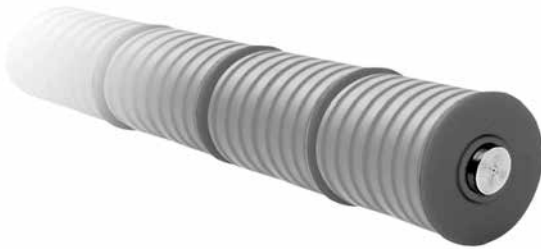

Material: Impact resistant, green HDPE. 3/4" roller is orange HDPE.

R3
Return Roller

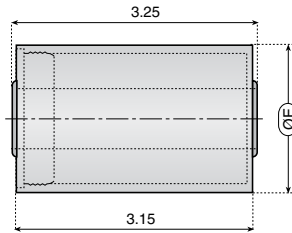

Part Number	Ref. Code	Color (G=Green, O=Orange)	Shaft Sized Bore Diameter	E Roller Dia.
12831	R3-18-50	G	18mm or 11/16 in.	1.97
12835	R3-18-60	G	18mm or 11/16 in.	2.36
32892	R3-75-50	O	3/4 in.	1.97
32836	R3-75-60	O	3/4 in.	2.36
12892	R3-20-50	G	20mm	1.97
12836	R3-20-60	G	20mm	2.36

R15
Return Roller

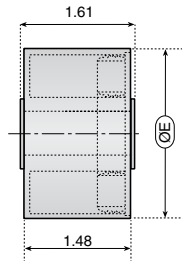

Part Number	Ref. Code	Color (G=Green, O=Orange)	Shaft Sized Bore Diameter	E Roller Dia.
121965	R15-18-50	G	18mm or 11/16 in.	1.97
122111V	R15-18-60	G	18mm or 11/16 in.	2.36
321966	R15-75-50	O	3/4 in.	1.97
32535	R15-75-60	O	3/4 in.	2.36
12535V	R15-20-60	G	20mm	2.36

RF3
Return Roller with Flange

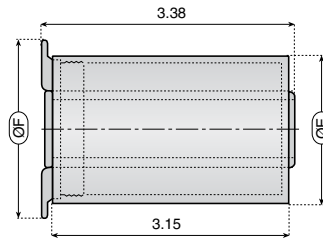

Part Number	Ref. Code	Color (G=Green, O=Orange)	Shaft Sized Bore Diameter	F Flange Dia.	E Roller Dia.
12833	RF3-18-50	G	18mm or 11/16 in.	2.56	1.97
12837	RF3-18-60	G	18mm or 11/16 in.	2.95	2.36
32763	RF3-75-50	O	3/4 in.	2.56	1.97
32838	RF3-75-60	O	3/4 in.	2.95	2.36
12763	RF3-20-50	G	20mm	2.56	1.97
12838	RF3-20-60	G	20mm	2.95	2.36

RF15
Return Roller with Flange

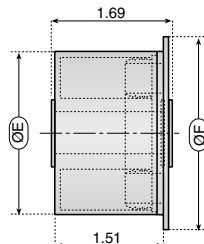

Part Number	Ref. Code	Color (G=Green, O=Orange)	Shaft Sized Bore Diameter	F Flange Dia.	E Roller Dia.
121969F	RF15-18-50	G	18mm or 11/16 in.	2.56	1.97
122114V	RF15-18-60	G	18mm or 11/16 in.	2.95	2.36
321970F	RF15-75-50	O	3/4 in.	2.56	1.97
32536	RF15-75-60	O	3/4 in.	2.95	2.36
121970F	RF15-20-50	G	20mm	2.56	1.97
12536V	RF15-20-60	G	20mm	2.95	2.36

Return Rollers

Material: Impact resistant, green HDPE with thermoplastic rubber cover. 3/4" roller is orange HDPE.

R3B

Return Roller with Rubber Surface

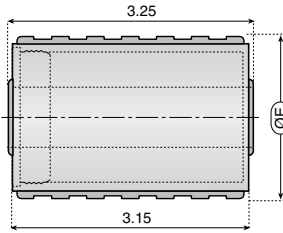

Part Number	Ref. Code	Color (G=Green) (O=Orange)	Shaft Sized Bore Diameter	E Roller Dia.
12831RN	R3B-18-50	G	18mm or 11/16 in.	2.24
12835RN	R3B-18-60	G	18mm or 11/16 in.	2.64
32892RN	R3B-75-50	O	3/4 in.	2.24
32836RN	R3B-75-60	O	3/4 in.	2.64
12892RN	R3B-20-50	G	20mm	2.24
12836RN	R3B-20-60	G	20mm	2.64

R15B

Return Roller with Rubber Surface

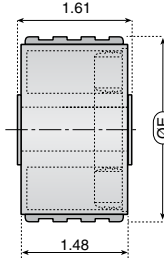

Part Number	Ref. Code	Color (G=Green) (O=Orange)	Shaft Sized Bore Diameter	E Roller Dia.
122111RN	R15B-18-60	G	18mm or 11/16 in.	2.64
321966RN	R15B-75-50	O	3/4 in.	2.24
32535RN	R15B-75-60	O	3/4 in.	2.64
121966RN	R15B-20-50	G	20mm	2.24
12535RN	R15B-20-60	G	20mm	2.64

RF3B

Return Roller with Flange and Rubber Surface

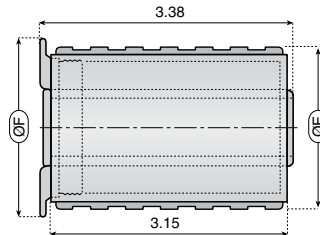

Part Number	Ref. Code	Color (G=Green) (O=Orange)	Shaft Sized Bore Diameter	F Flange Dia.	E Roller Dia.
32763RNF	RF3B-75-50	O	3/4 in.	2.56	2.24
32838RNF	RF3B-75-60	O	3/4 in.	2.95	2.64

RF15B

Return Roller with Flange and Rubber Surface

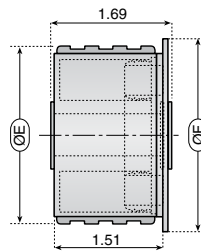

Part Number	Ref. Code	Color (G=Green) (O=Orange)	Shaft Sized Bore Diameter	F Flange Dia.	E Roller Dia.
121969RNF	RF15B-18-50	G	18mm or 11/16 in.	2.56	2.24
122114RN	RF15B-18-60	G	18mm or 11/16 in.	2.95	2.64
321970RNF	RF15B-75-50	O	3/4 in.	2.56	2.24
32536RN	RF15B-75-60	O	3/4 in.	2.95	2.64
121970RNF	RF15B-20-50	G	20mm	2.56	2.24
12536RN	RF15B-20-60	G	20mm	2.95	2.64

SE-582

Threaded End for 3/4 dia. Shafts

Use this insert and 3/4 x .065 tubing to make threaded shafts in minutes, with just a saw. Bypass machine shop delays and use less material. Cut tubing to length, deburr, and press in VG-SE-582 shaft ends.

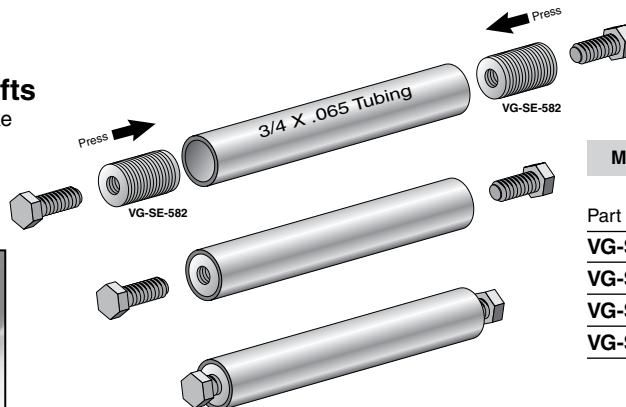

Materials: Stainless Steel.

Part Number	End Insert Thread	Pull Out Load (lbs.)
VG-SE-582-516	5/16-18	900
VG-SE-582-38	3/8-16	900
VG-SE-582-M8	M8	900
VG-SE-582-M10	M10	900

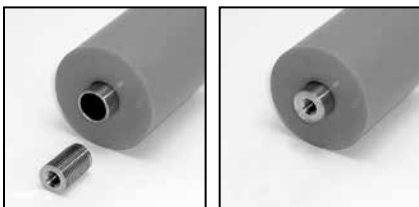

Sprockets, Wear
Strips, Chain Guides



Return Rollers

Sprockets, Wear
Strips, Chain Guides

RP3

Solid
Return Roller

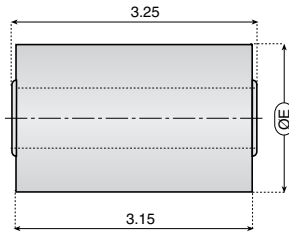

Material: Black Polypropylene.

Part Number	Ref. Code	Color (G=Green) (O=Orange)	Shaft Sized Bore Diameter	E Roller Dia.
121985	RP3-18-50	G	18mm or 11/16 in.	1.97
121987	RP3-18-60	G	18mm or 11/16 in.	2.36
321991	RP3-75-50	O	3/4 in.	1.97
321993	RP3-75-60	O	3/4 in.	2.36
121991	RP3-20-50	G	20mm	1.97

RP3B

Solid Return
Roller with
Rubber Surface

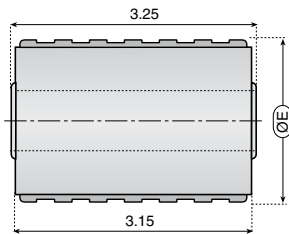

Material: Black Polypropylene with thermoplastic rubber cover.

Part Number	Ref. Code	Color (G=Green) (O=Orange)	Shaft Sized Bore Diameter	E Roller Dia.
121987RN	RP3B-18-60	G	18mm or 11/16 in.	2.64
321993RN	RP3B-75-60	O	3/4 in.	2.64

RF

Roller Flange



Material: Impact resistant, green HDPE.

Flange for 3/4 inch shaft is orange HDPE.

Part Number	Ref. Code	Shaft Sized Bore Diameter	Flange Diameter
12841	RF-18-70	18mm or 11/16 in.	2.75
32534	RF-75-70	3/4 in.	2.75
12534	RF-20-70	20mm	2.75

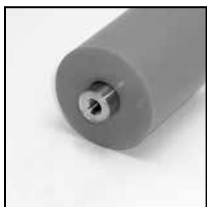

Bypass machine shop delays!

Make 3/4 in. diameter threaded shafts in minutes using VG-SE-582 shaft ends. See page 165 for details

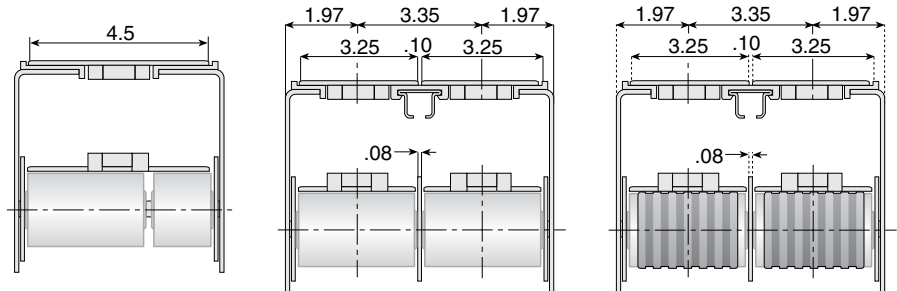

Notes



A series of horizontal lines for taking notes, starting below the 'Notes' header and ending above the footer.



ValuFlex is a patented, serpentine wear strip system that solves conveyor return problems associated with metal and plastic slat top chains and wide modular type belts. The ValuFlex system uses standardized parts that help reduce design and fabrication time. ValuFlex can be easily installed, new or retrofitted, without the use of special tools. The absence of moving parts means less noise, less wear, and significantly lower maintenance and replacement cost. As added benefits, serpentes increase the useful life of chains and provide increased chain stability at higher speeds. The serpentine pattern distributes wear evenly across belt surfaces, providing trouble-free service and increased belt life. Serpentine systems permit high speed operation by eliminating the pulsation inherent in some roller returns.

ValuFlex is also used as a light duty support grid for lightly loaded, modular style belts and has been proven useful when used with other Valu Guide components as a hold down system for tops, lids, or flaps on air or mechanical conveyors. Low friction ValuFlex UHMW serpentine profiles last for years without the need for lubrication or maintenance, and operate equally well in dry or wet environments.

Sprockets, Wear Strips, Chain Guides

Patented Simplicity!

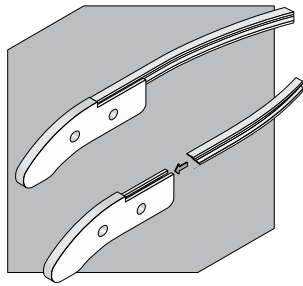
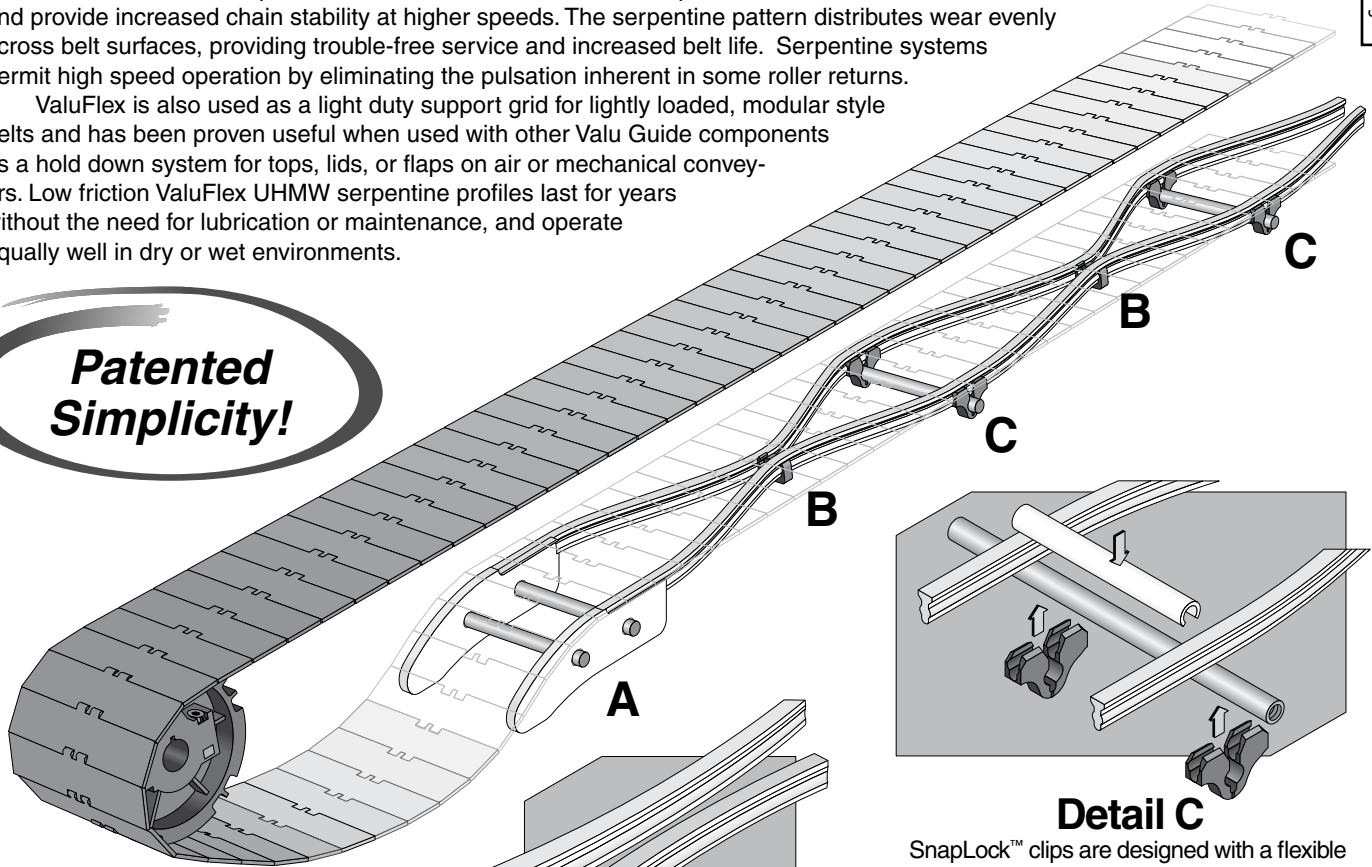

Detail A

ValuFlex™ chain return shoes are made from the same durable UHMW material as the extruded profiles. They are designed to provide a generous entry radius, feeding the chain smoothly onto the serpentine profile for a trouble free transition. Conveyor design and fabrication is simplified by the geometry of the shoe and the location of the mounting holes.

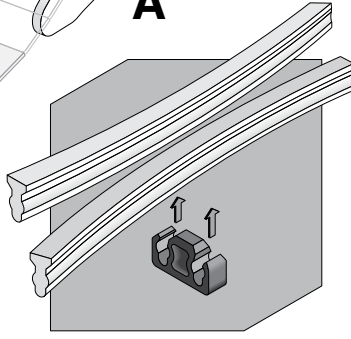

Detail B

Intermediate PinchLock™ clips reduce the number of cross members required by 50 percent. Most serpentine systems require a mid-cycle crossmember to pull the profiles together. With ValuFlex, on normal cycles of 18"-24", no center member is necessary. Midway between the cross rods, simply snap the PinchLock clips onto the serpentine profiles to complete the cycle which, in effect, eliminates every other cross support.

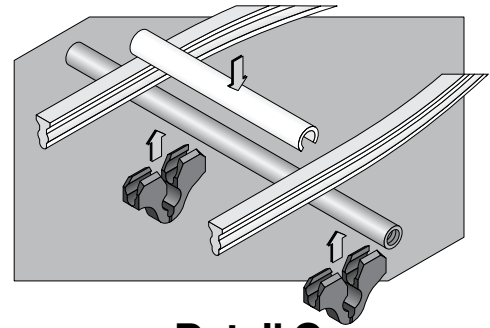

Detail C

SnapLock™ clips are designed with a flexible hinge, enabling them to snap around the cross rod. Position the clips in the desired location along the rod. Then snap the ValuFlex serpentine profile into the clips by hand — no special tools are necessary. This assembled configuration creates a unique interference lock throughout the clip, profile, and rod, securing their relative positions. ValuFlex serpentine profiles are now securely locked to the cross rods and will not work up out of their slots, as other serpentine fabrications are prone to do. Splicing, though easily accomplished, is rarely needed because ValuFlex serpentine profiles are available in standard 100' coils (longer if needed), not the 10' lengths typical of "cut strip" serpentine systems.



The ValuFlex system combines four basic elements to form a complete, simple and cost-effective chain return solution. Flexible design accommodates virtually every width and length of conveyor. ValuFlex can be installed during or after conveyor frame assembly, or retro-fits can be installed directly on the existing conveyor with very little disassembly required.



Serpentine Chain Return System

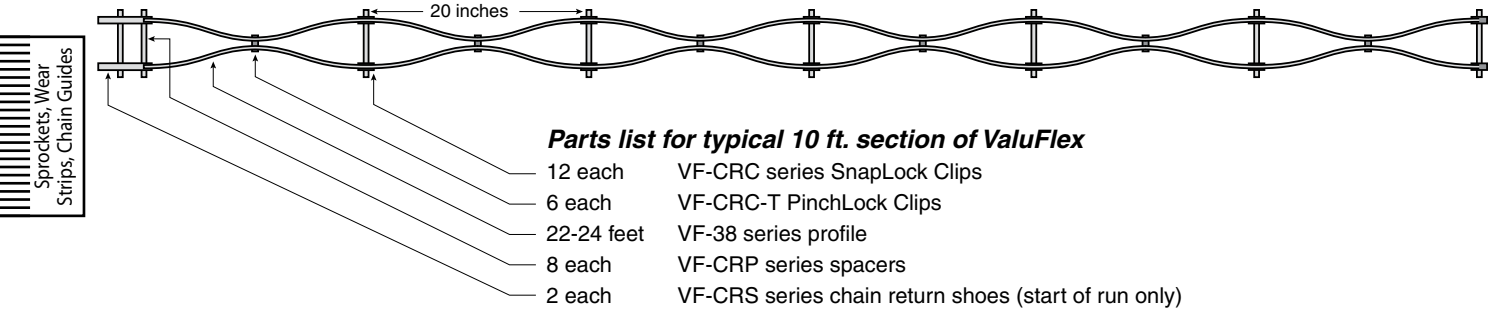

Parts list for typical 10 ft. section of ValuFlex

- 12 each VF-CRC series SnapLock Clips
- 6 each VF-CRC-T PinchLock Clips
- 22-24 feet VF-38 series profile
- 8 each VF-CRP series spacers
- 2 each VF-CRS series chain return shoes (start of run only)

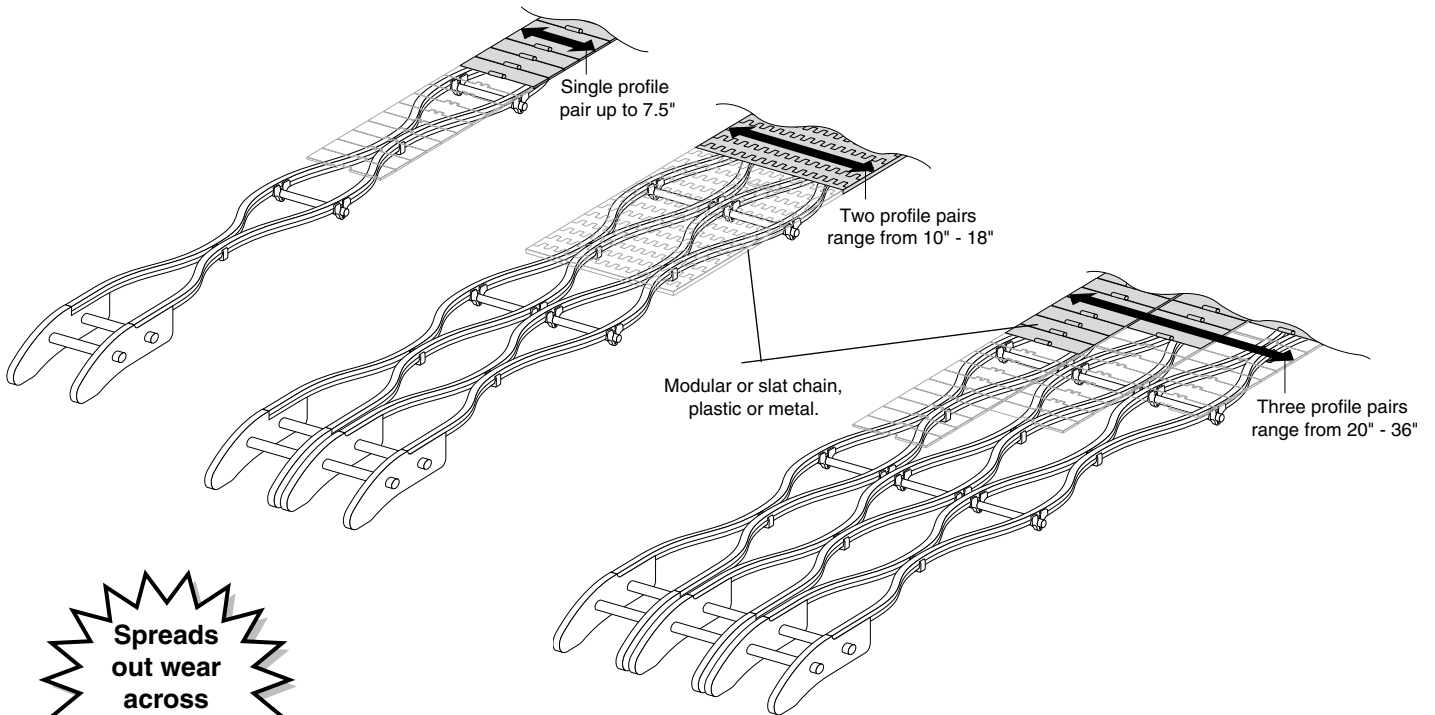

Spreads out wear across chain!

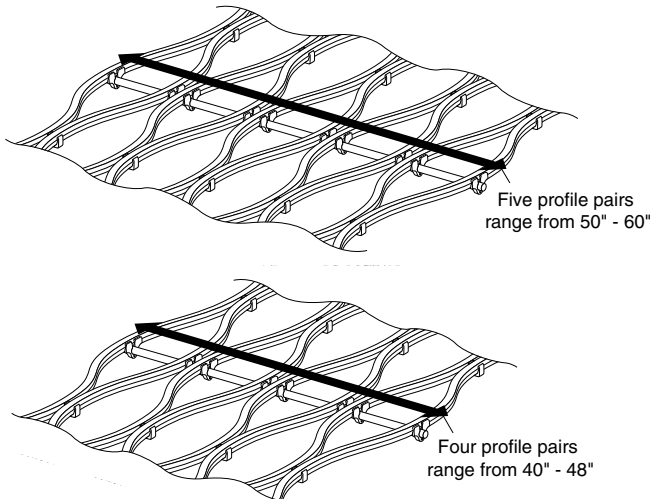

System Considerations	Roller	ValuFLEX
Cost-Effective/Labor Saving	X	X
Flexible Design/Standard Parts	X	X
Trouble Free/Secure		X
Guaranteed Materials		X
Long Life/Lower Chain Wear		X
Low/No Maintenance		X
Stable at High Speeds		X
Universal Belt Compatibility	X	X
Industry Proven Reliable	X	X



The ValuFlex System is designed to be used on cross rods commonly used as supports and spacers. The pre-engineered ValuFlex elements, combined with cross rods, will accommodate a broad range of modular frame designs for complete return supports, including chain return shoes.

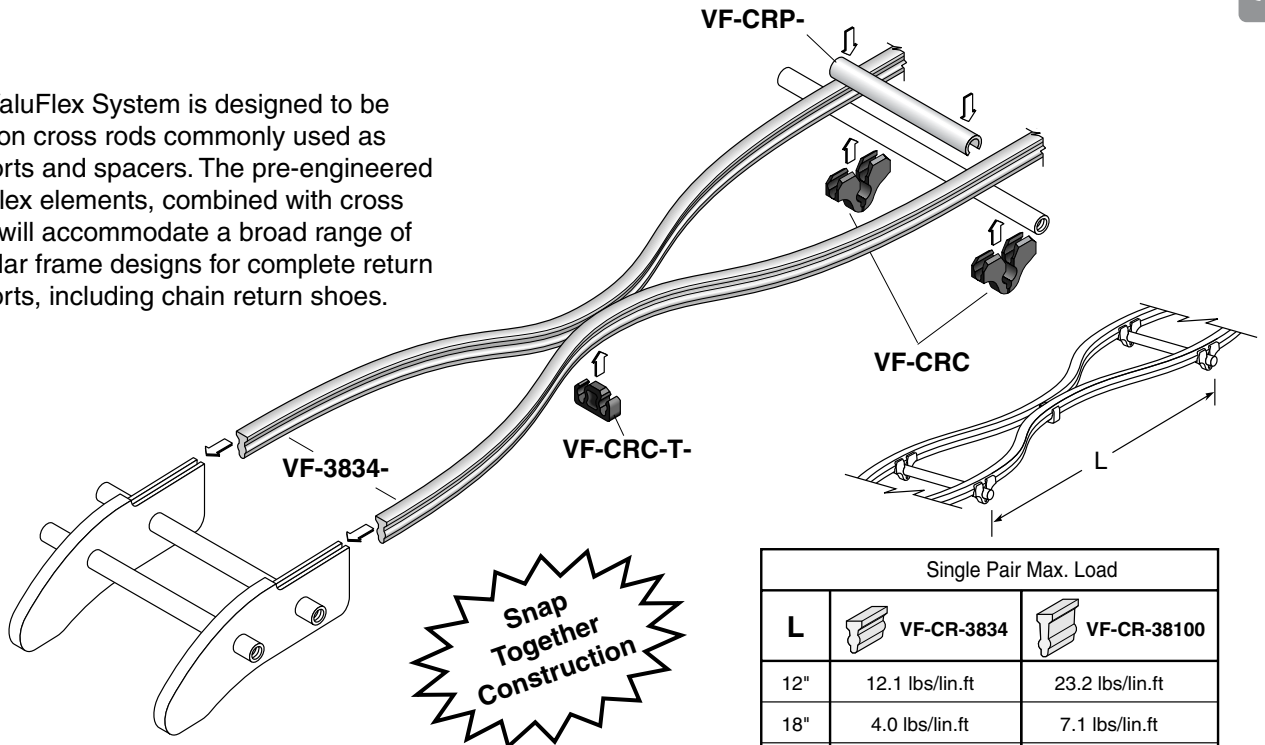

Sprockets, Wear Strips, Chain Guides

Single Pair Max. Load		
L	VF-CR-3834	VF-CR-38100
12"	12.1 lbs/lin.ft	23.2 lbs/lin.ft
18"	4.0 lbs/lin.ft	7.1 lbs/lin.ft
24"	2.3 lbs/lin.ft	3.7 lbs/lin.ft

3834

Standard Duty Profile

Securely snaps and locks into ValuFlex clips and return shoes providing a smooth and level return surface.

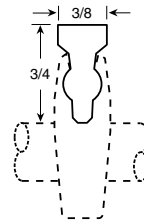
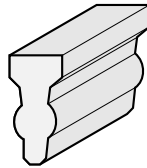

Material: UHMW.



Part Number	Height (in.)	Length
VF-CR-3834-50	3/4	50
VF-CR-3834-100	3/4	100



Patent # 336,712

38100

Heavy Duty Profile

Securely snaps and locks into ValuFlex clips and return shoes providing a smooth and level return surface.

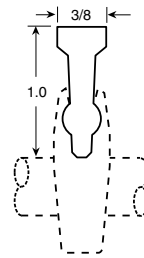
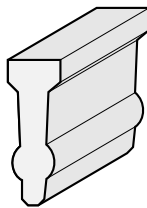

Part Number	Height (in.)	Length
VF-CR-38100-50	1	50
VF-CR-38100-100	1	100

CRP

Full Round Spacer

Maintains clip spacing, at any chain speed, by resisting the natural side forces of drifting and vibrating chain.

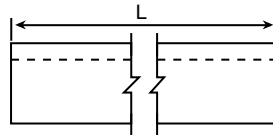
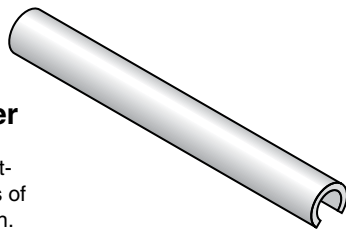

Part Number	Ø Rod	Chain Width	L
VF-CRP-325	1/2 or 9/16*	3.25	2.3
VF-CRP-450	1/2 or 9/16*	4.50	3.55
VF-CRP-600	1/2 or 9/16*	6.0	5.05
VF-CRP-750	1/2 or 9/16*	7.50	6.05
VF-CRP-8FT	1/2 or 9/16*	8'	96
VF-CRP5-325	5/8	3.25	2.3
VF-CRP5-450	5/8	4.50	3.55
VF-CRP5-600	5/8	6.0	5.05
VF-CRP5-750	5/8	7.50	6.05
VF-CRP5-8FT	5/8	8'	96

*1/4" sch. 80 pipe diameter.



SnapLock™ and PinchLock™ Clips

Sprockets, Wear Strips, Chain Guides

CRC

SnapLock™ Clip
Securely locks ValuFlex profiles onto rod or pipe.

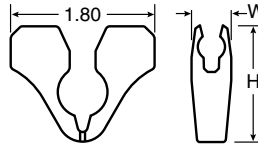
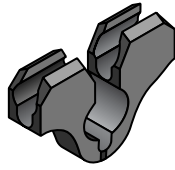

Material: Black acetal.

Part Number	H	W	Ø Rod
VF-CRC-12	1.30	.45	1/2
VF-CRC-58	1.43	.50	5/8 or M16



Patent # 340,564



CRCP

SnapLock™ Clip with pin
Securely locks ValuFlex profiles onto rod or pipe. Pins act as automatic side-frame spacers.

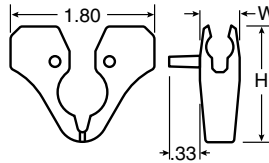
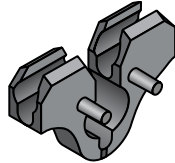

Part Number	H	W	Ø Rod
VF-CRCP-12	1.30	.45	1/2
VF-CRCP-58	1.43	.50	5/8 or M16

CRA

SnapLock™ Clip
Fastens onto 7 to 11 gauge angle bar cross supports. Locks ValuFlex profiles securely in place. Clip is held secure with VG-750-01 drive rivet, which is included.

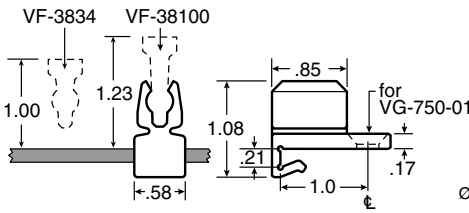

Part Number
VF-CRA

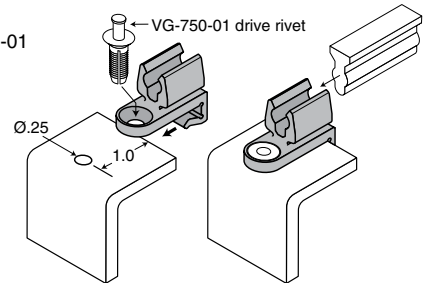

Patent # 6,533,108

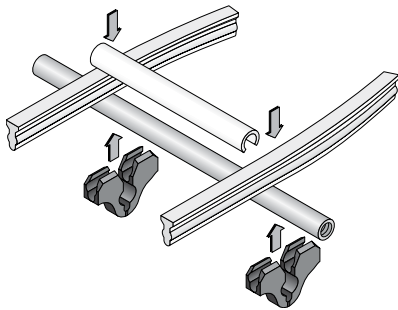

SnapLock Clips fit onto the cross rods and hold the serpentine profile in position.

Typical SnapLock™ Mounting Applications:

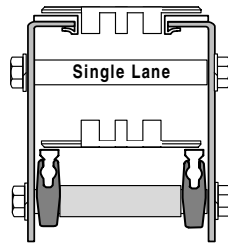

VF-CRC-12

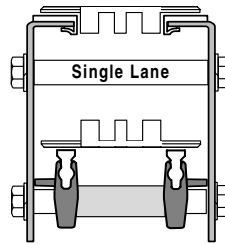

VF-CRCP-12

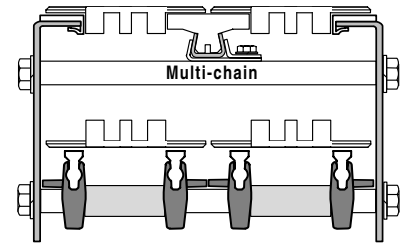

CRC-T

PinchLock™ Clip
Installed at the midpoint of the ValuFlex serpentine span, pinching and locking the two strips of ValuFlex profiles together. Recommended for use with all chain widths when cross rod centers are 14" or greater.

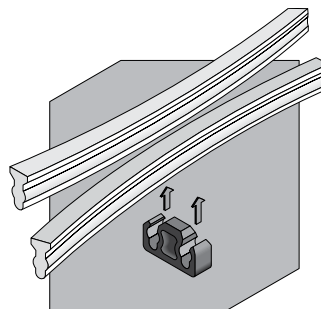
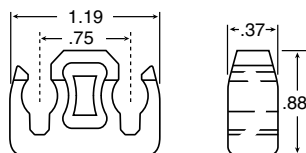
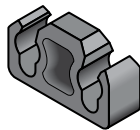

Material: Black acetal.

Part Number
VF-CRC-T



SYSTEM PLAST™

©2015 Regal-Beloit Corporation, All Rights Reserved.

Chain Return Shoes and Cross Rods



Sprockets, Wear Strips, Chain Guides

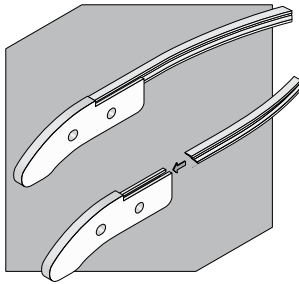

ValuFlex serpentine profiles slide into the return shoe's slot to ensure a smooth, trouble-free transition. Pinning the profile to the shoe is a safety precaution to prevent separation caused by a snag or broken chain segment.

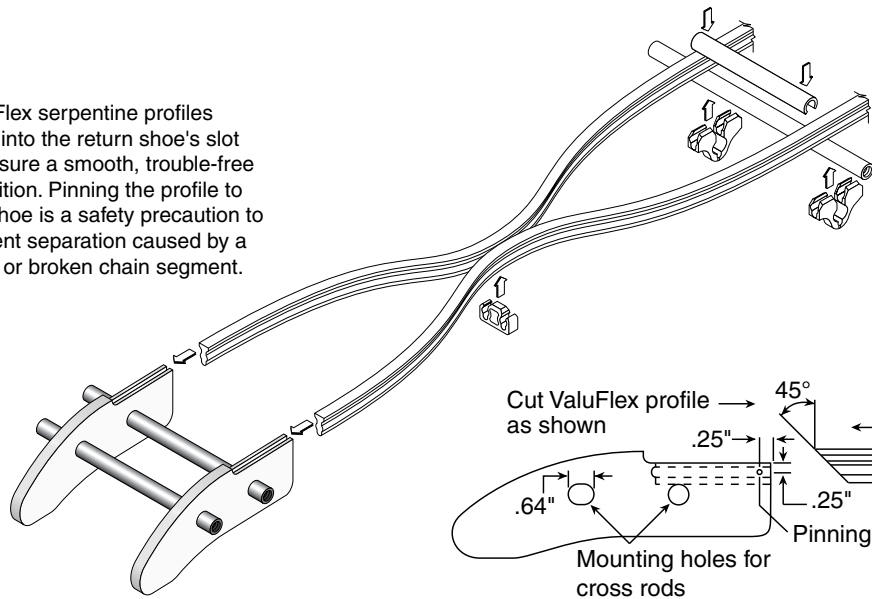

CRS-34

Chain Return Shoe

For use with VF-CR-3834 profile. Designed with a generous entry radius to feed the chain smoothly onto the serpentine profile.

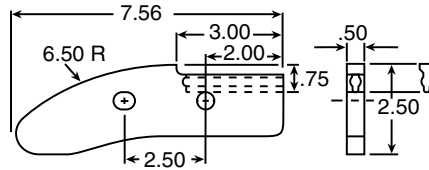

Material: UHMW.

Part Number	Profile	Ø Cross Rod (in.)
VF-CRS-34	VF-CR-3834	1/2
VF-CRS-34-58	VF-CR-3834	5/8

CRS-100

Chain Return Shoe

For use with VF-CR-38100 profile. Designed with a generous entry radius to feed the chain smoothly onto the serpentine profile.

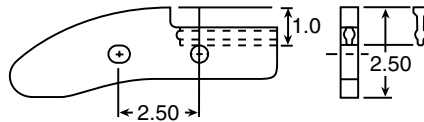

VF-CRS-100	VF-CR-38100	1/2
VF-CRS-100-58	VF-CR-38100	5/8

Shown are dimensional guidelines for positioning chain return shoes

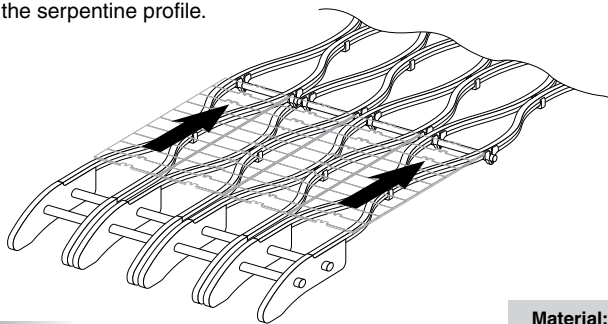
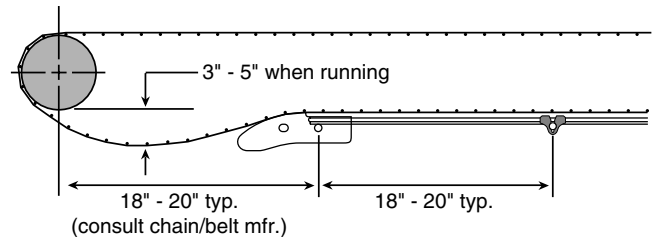

CR4

Round Cross Rod

Commonly used as side-frame spacers and to support the entire ValuFlex system.

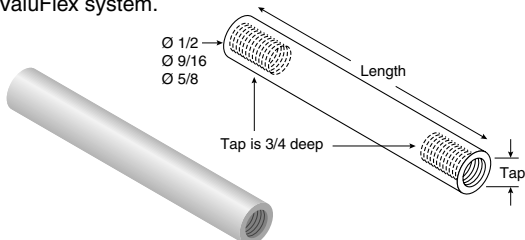

Material: 303 stainless steel.

Ø 1/2" Part Number	Length	Tap	Ø 9/16" Part Number	Length	Tap
VF-CR4-SS-0325-516	3.50	5/16-18	VF-CR4.5-SS-0325-38	3.50	3/8-16
VF-CR4-SS-0325-38	3.50	3/8-16	VF-CR4.5-SS-0400-38	4.25	3/8-16
VF-CR4-SS-0400-516	4.25	5/16-18	VF-CR4.5-SS-0450-38	4.75	3/8-16
VF-CR4-SS-0400-38	4.25	3/8-16	VF-CR4.5-SS-0600-38	6.25	3/8-16
VF-CR4-SS-0450-516	4.75	5/16-18	VF-CR4.5-SS-0750-38	7.75	3/8-16
VF-CR4-SS-0450-38	4.75	3/8-16			
VF-CR4-SS-0600-516	6.25	5/16-18			
VF-CR4-SS-0600-38	6.25	3/8-16			
VF-CR4-SS-0750-516	7.75	5/16-18			
VF-CR4-SS-0750-38	7.75	3/8-16			

Ø 5/8" Part Number	Length	Tap
VF-CR5-SS-0325-38	3.50	3/8-16
VF-CR5-SS-0400-38	4.25	3/8-16
VF-CR5-SS-0450-38	4.75	3/8-16
VF-CR5-SS-0600-38	6.25	3/8-16
VF-CR5-SS-0750-38	7.75	3/8-16

Reversible Chain Return Shoes and Cross Rods



Sprockets, Wear Strips, Chain Guides

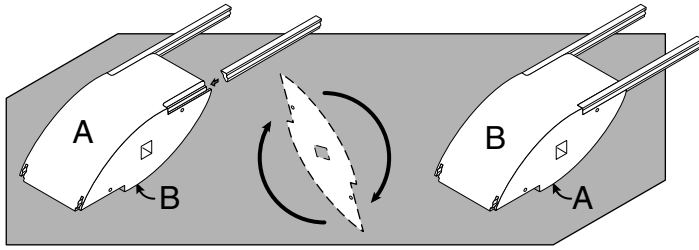

Twice the Life!

A unique, patented feature of this chain return shoe is its reversibility. When side **A** is worn past its useful life, simply unfasten the profile, rotate the shoe so side **B** faces up and reattach the profile - it's a built-in spare.



Patent # 5,310,047

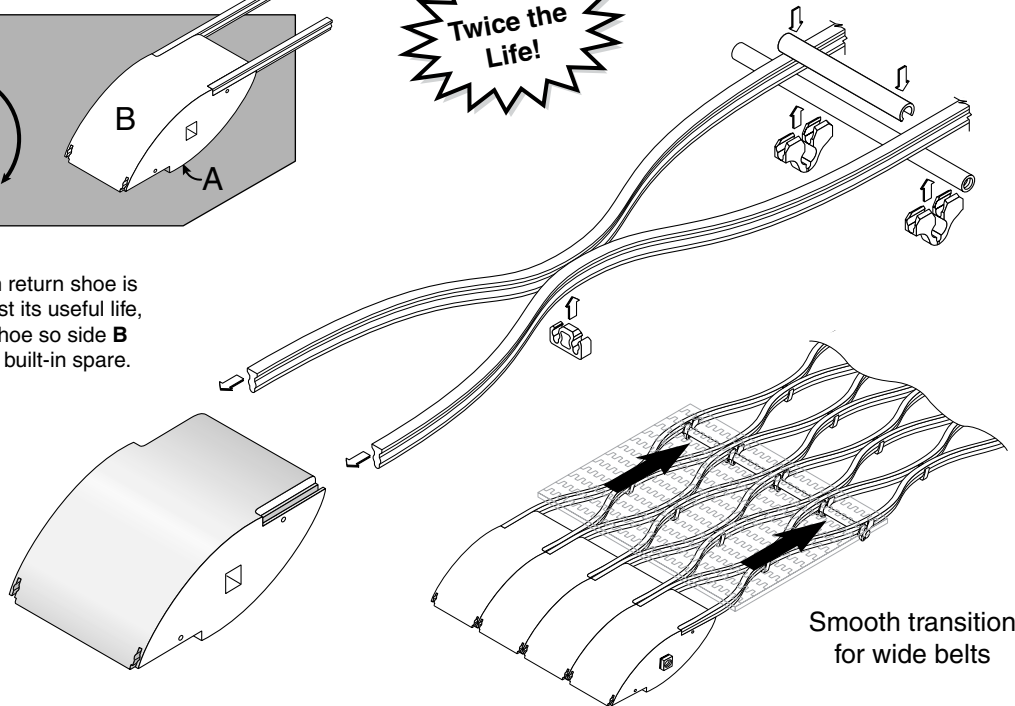

Smooth transition for wide belts

CRSR-34

Reversible Chain Return Shoe

For use with VF-CR-3834 profile. Designed primarily for slat-top hinged chains. Shoe can be used individually with the appropriate chain or ganged together for wider belts.

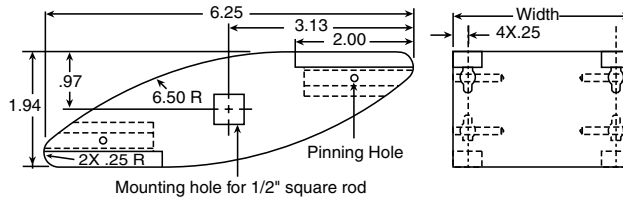

Material: UHMW.

Part Number	Width (in.)
VF-CRCSR-34-0325	3
VF-CRCSR-34-0400	3 3/4
VF-CRCSR-34-0450	4 1/4
VF-CRCSR-34-0600	5 3/4
VF-CRCSR-34-0750	7

CRSR-100

Reversible Chain Return Shoe

For use with VF-CR-38100 profile. Designed primarily for slat-top hinged chains. Shoe can be used individually with the appropriate chain or ganged together for wider belts.

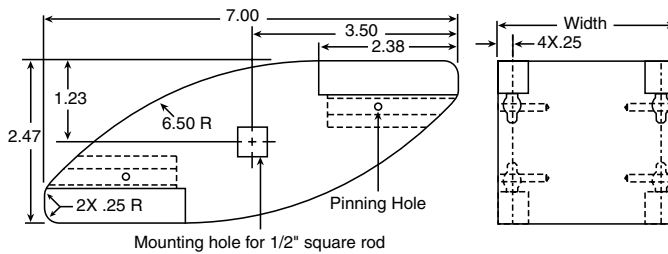

Part Number	Width (in.)
VF-CRCSR-100-0325	3
VF-CRCSR-100-0400	3 3/4
VF-CRCSR-100-0750	7

CRQ

Square Cross Rod

Used with VF-CRCSR chain return shoes, they fit into a square slot in the return shoe which is easily centered with the snap rings provided.

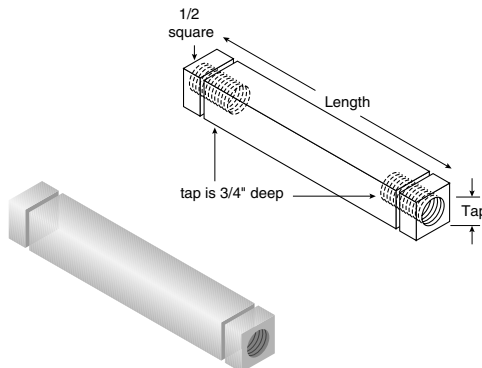

Material: 303 stainless steel.

Part Number	Length	Tap
VF-CRQ-SS-0325-516	3.50	5/16-18
VF-CRQ-SS-0325-38	3.50	3/8-16
VF-CRQ-SS-0400-516	4.25	5/16-18
VF-CRQ-SS-0400-38	4.25	3/8-16
VF-CRQ-SS-0450-516	4.75	5/16-18
VF-CRQ-SS-0450-38	4.75	3/8-16
VF-CRQ-SS-0600-516	6.25	5/16-18
VF-CRQ-SS-0750-516	7.75	5/16-18
VF-CRQ-SS-0750-38	7.75	3/8-16

SYSTEM PLAST™

©2015 Regal-Beloit Corporation, All Rights Reserved.

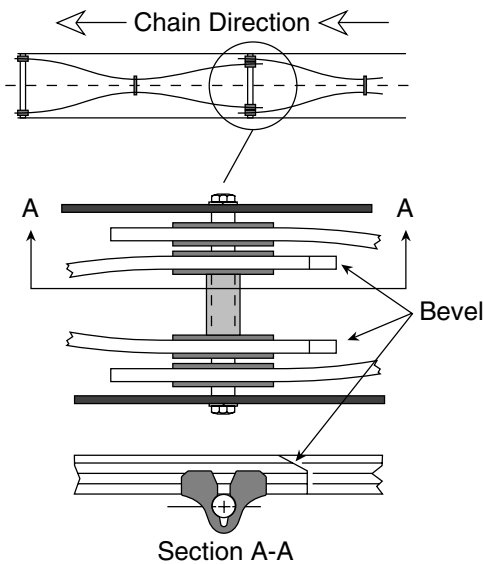

Splicing with the overlap method is quick and easy with ValuFlex.

Splicing

When necessary, splicing is quick, easy, and trouble-free. The overlap method pictured here is preferred. Pick a convenient cross rod and terminate the ValuFlex serpentine profiles 1" to 2" past the ends of the clips. Attach new clips on the same rod, inside those just mentioned. Begin the new ValuFlex profiles, again leaving 1" to 2" ahead of the clip. Before snapping the profiles into place, be sure to bevel the edges to avoid any possible snag by the chain or belt (as shown). Never try to butt-splice two profiles by joining them into the same clip.

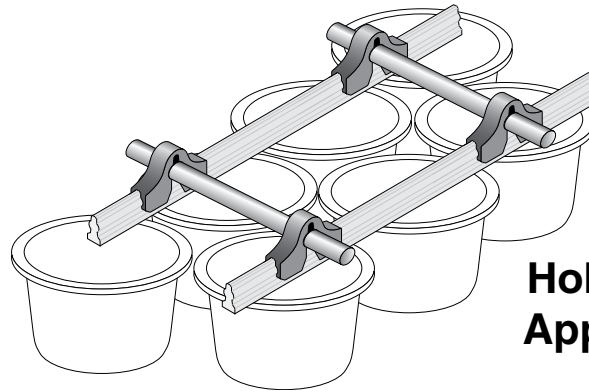

Hold-Down Application

Installation Instructions

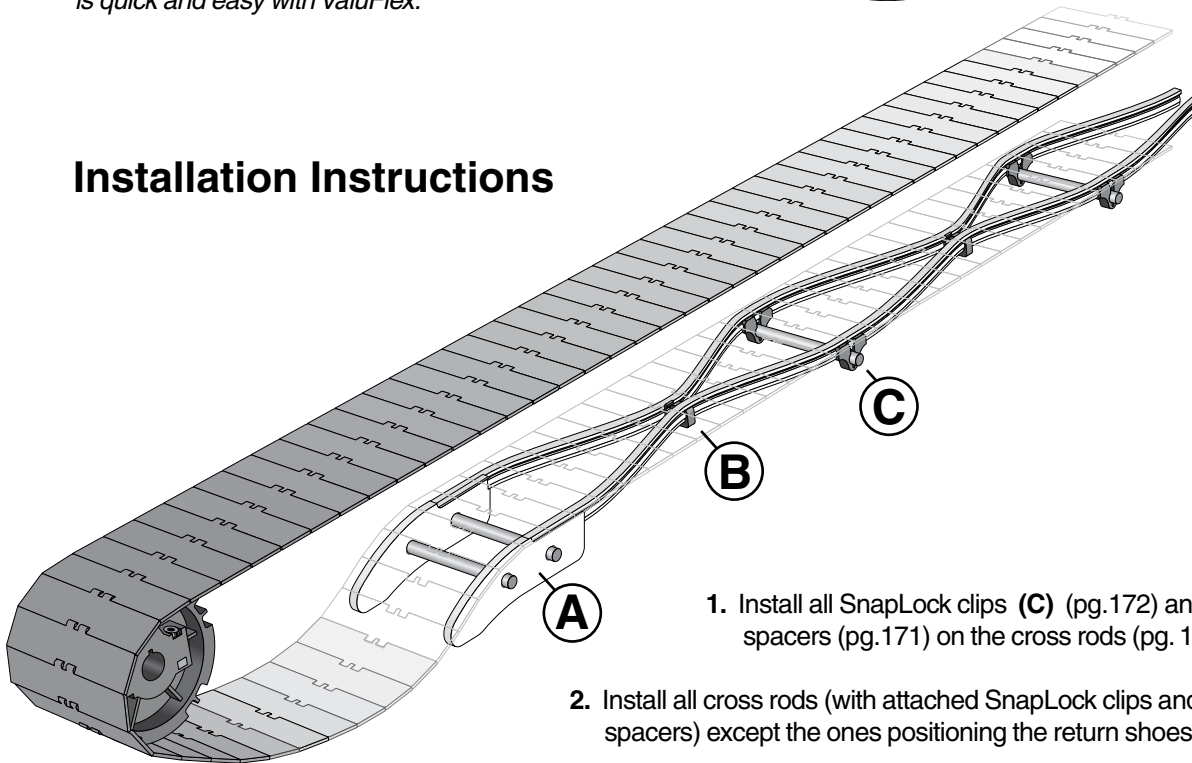

1. Install all SnapLock clips **(C)** (pg.172) and appropriate spacers (pg.171) on the cross rods (pg. 173-174).
2. Install all cross rods (with attached SnapLock clips and appropriate spacers) except the ones positioning the return shoes.
3. Thread the ValuFlex serpentine profiles (pg. 171) through the conveyor frame and fasten the profiles to the return shoes **(A)** (pg. 173-174).
4. Mount shoes on the appropriate cross rods and fasten the rods in place.
5. Starting at the return shoe, move to the next cross rod and snap the serpentine profile into the clips. If intermediate PinchLock clips **(B)** (pg. 172) are being used, install the first one now between the return shoe(s) and the first cross rod/SnapLock assembly.
6. Repeat this process, first installing the profile into the next cross rod/SnapLock clip assembly and then installing a PinchLock clip between two new secured rod locations.

Sprockets, Wear Strips, Chain Guides



Conveyor Wear Bed

Chain Guides and Wear Beds

Valu Guide rail can be used as a guide or wear strip for wide metal or plastic belting and slat top chain. These rail shapes are also shown with conveyor guide rail on page 202-205.



Natural White UHMW

Material: UHMW Insert and stainless steel or galvanized steel sheath, 14 gauge.

Sprockets, Wear Strips, Chain Guides

T-1.25

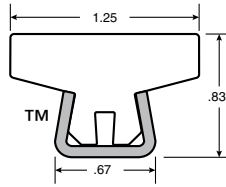
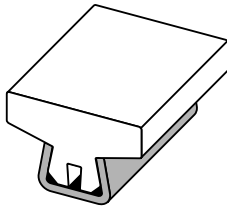

TS-1.25

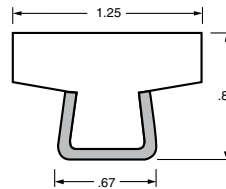
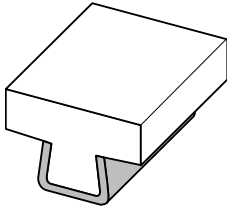

LT

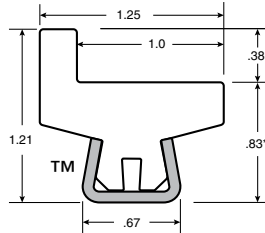
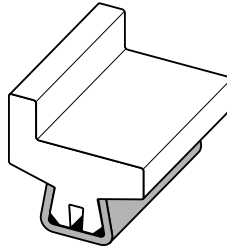

LTS

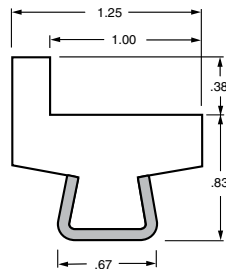
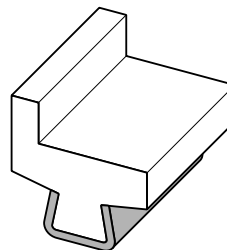

Stainless	Galvanized	Length (ft.)
VG-SST-1.25-8	VG-GST-1.25-8	8
VG-SST-1.25-10	VG-GST-1.25-10	10
VG-SST-1.25-12	VG-GST-1.25-12	12
VG-SST-1.25-20	VG-GST-1.25-20	20

VG-SSTS-1.25-8	-	8
VG-SSTS-1.25-10	-	10
VG-SSTS-1.25-12	-	12
VG-SSTS-1.25-20	-	20

VG-SSLT-1.0x.38-8	VG-GSLT-1.0x.38-8	8
VG-SSLT-1.0x.38-10	VG-GSLT-1.0x.38-10	10
VG-SSLT-1.0x.38-12	VG-GSLT-1.0x.38-12	12
VG-SSLT-1.0x.38-20	VG-GSLT-1.0x.38-20	20

VG-SSLTS-1.0x.38-8	-	8
VG-SSLTS-1.0x.38-10	-	10
VG-SSLTS-1.0x.38-12	-	12
VG-SSLTS-1.0x.38-20	-	20

*Tolerance on height is ± 0.025
AISI 316 stainless steel are available on a special order basis.

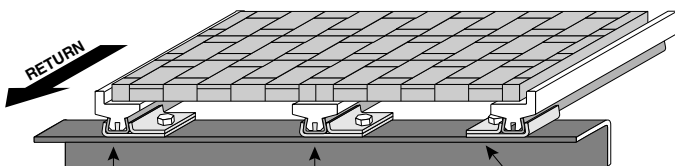
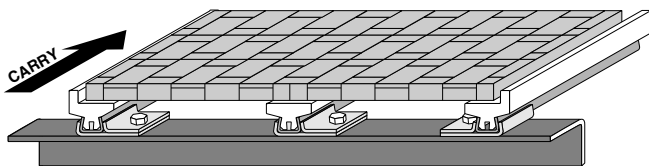

VG-SSLT-1.0x.38- rail VG-SST-1.25- rail VG-012-01 single rail clamps

See page 218 for details on wear bed grid construction.

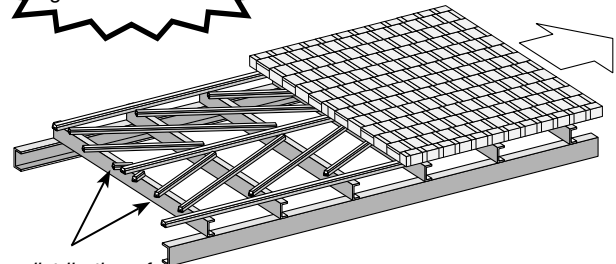

Note: For even distribution of load over width of belt, use the same type of guide rail through out your application.

Conveyor Wear Bed with Premium UHMW Materials



Gray Nolu-S

Self lubricating Nolu-S UHMW insert and stainless steel sheath, 14 gauge.



Static Dissipating

Static dissipating UHMW insert and stainless steel sheath, 14 gauge.

Sprockets, Wear Strips, Chain Guides

		Length (ft.)
VG-SST-1.25-NS-8	VG-SST-1.25-SD-8	8
VG-SST-1.25-NS-10	VG-SST-1.25-SD-10	10
VG-SST-1.25-NS-12	VG-SST-1.25-SD-12	12
VG-SST-1.25-NS-20	VG-SST-1.25-SD-20	20
VG-SSTS-1.25-NS-8	-	8
VG-SSTS-1.25-NS-10	VG-SSTS-1.25-SD-10	10
VG-SSTS-1.25-NS-12	VG-SSTS-1.25-SD-12	12
VG-SSTS-1.25-NS-20	VG-SSTS-1.25-SD-20	20
VG-SSLT-1.0x.38-NS-8	VG-SSLT-1.0x.38-SD-8	8
VG-SSLT-1.0x.38-NS-10	VG-SSLT-1.0x.38-SD-10	10
VG-SSLT-1.0x.38-NS-12	VG-SSLT-1.0x.38-SD-12	12
VG-SSLT-1.0x.38-NS-20	VG-SSLT-1.0x.38-SD-20	20
-	VG-SSLTS-1.0x.38-SD-8	8
VG-SSLTS-1.0x.38-NS-10	VG-SSLTS-1.0x.38-SD-10	10
VG-SSLTS-1.0x.38-NS-12	VG-SSLTS-1.0x.38-SD-12	12
VG-SSLTS-1.0x.38-NS-20	VG-SSLTS-1.0x.38-SD-20	20

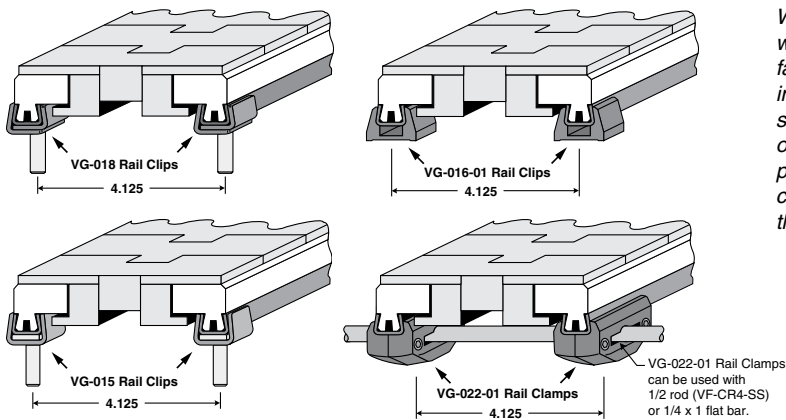

Tab Chain Guide mounting options

Important Note:

When Valu Guide Rail is used as a wear strip, the UHMW insert should be fastened to the metal sheath at the leading end of the rail. Using a sheet metal screw through the back of the sheath or a heavy wire pin from the side should be adequate. This will prevent the insert from sliding within the sheath in the event the chain accidentally catches on a leading edge. This also allows for thermal expansion and contraction of the UHMW insert.

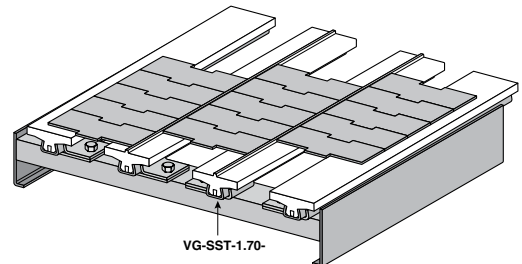
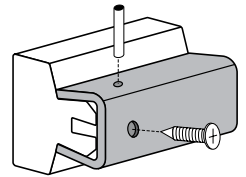

SYSTEM PLAST™



Conveyor Wear Bed

Valu Guide Tee Guide Rail can be used as a wear strip for wide metal or plastic belting and slat top chain. These rail shapes are also shown with conveyor guide rail on page 202-205.



Natural White UHMW

Material: UHMW Insert and stainless steel or galvanized steel sheath, 14 gauge.

Sprockets, Wear Strips, Chain Guides

T-1.60

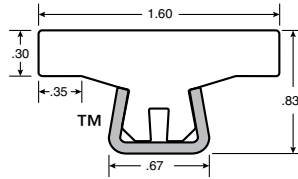
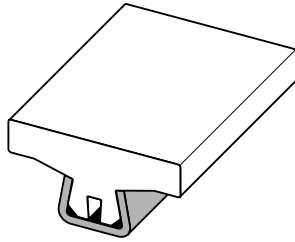

T-1.70

Ribbed wide Tee rail used as wear strip and support assembly for multi-lane 3/4 in. slat top chain.

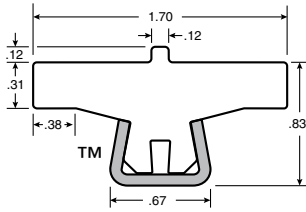
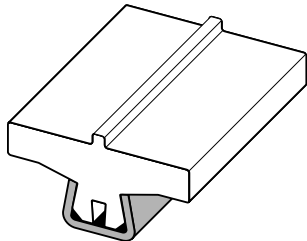

T-2.25

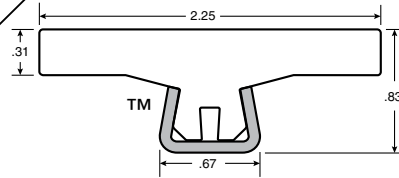
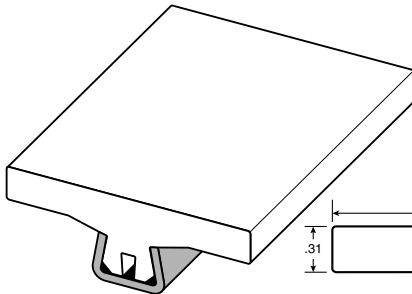

TG

Tab Chain Guide
Economical alternative to other chain guiding systems. For use with 882-4-1/2 and 882-LBP-3-3/4 style chains.

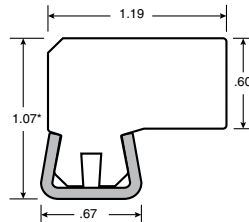
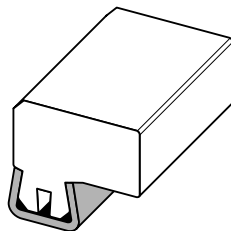

Stainless	Galvanized	Length (ft.)
VG-SST-1.60-8	VG-GST-1.60-8	8
VG-SST-1.60-10	VG-GST-1.60-10	10
VG-SST-1.60-12	VG-GST-1.60-12	12
VG-SST-1.60-20	VG-GST-1.60-20	20

VG-SST-1.70-8	VG-GST-1.70-8	8
VG-SST-1.70-10	VG-GST-1.70-10	10
VG-SST-1.70-12	-	12
VG-SST-1.70-20	-	20

VG-SST-2.25-8	VG-GST-2.25-8	8
VG-SST-2.25-10	VG-GST-2.25-10	10
VG-SST-2.25-12	VG-GST-2.25-12	12
VG-SST-2.25-20	VG-GST-2.25-20	20

VG-SSTG-02-8	VG-GSTG-02-8	8
VG-SSTG-02-10	VG-GSTG-02-10	10
VG-SSTG-02-12	VG-GSTG-02-12	12
VG-SSTG-02-20	VG-GSTG-02-20	20

*Tolerance on height is ± 0.025
AISI 316 stainless steel are available on a special order basis.

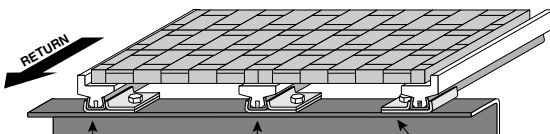
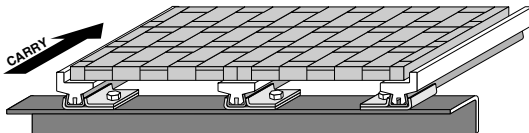

VG-SSLT-1.0x.38- rail VG-SST-1.25- rail VG-012-01 single rail clamps

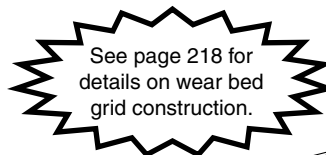

See page 218 for details on wear bed grid construction.

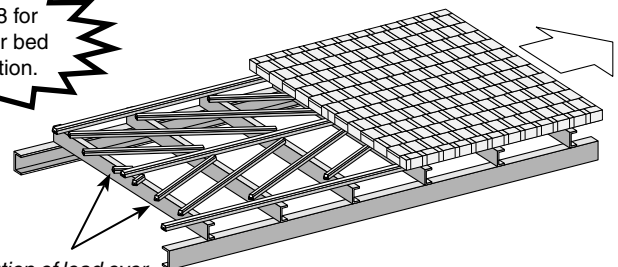

Note: For even distribution of load over width of belt, use the same type of guide rail through out your application.

SYSTEM PLAST™

©2015 Regal-Beloit Corporation, All Rights Reserved.

Conveyor Wear Bed with Premium UHMW Materials



Gray Nolu-S

Self lubricating Nolu-S UHMW insert and stainless steel sheath, 14 gauge.



Static Dissipating

Static dissipating UHMW insert and stainless steel sheath, 14 gauge.

Sprockets, Wear Strips, Chain Guides

		Length (ft.)
VG-SST-1.60-NS-8	VG-SST-1.60-SD-8	8
VG-SST-1.60-NS-10	VG-SST-1.60-SD-10	10
VG-SST-1.60-NS-12	VG-SST-1.60-SD-12	12
VG-SST-1.60-NS-20	VG-SST-1.60-SD-20	20
-	VG-SST-1.70-SD-8	8
VG-SST-1.70-NS-10	VG-SST-1.70-SD-10	10
-	VG-SST-1.70-SD-12	12
VG-SST-1.70-NS-20	VG-SST-1.70-SD-20	20
VG-SST-2.25-NS-8	VG-SST-2.25-SD-8	8
VG-SST-2.25-NS-10	VG-SST-2.25-SD-10	10
VG-SST-2.25-NS-12	VG-SST-2.25-SD-12	12
VG-SST-2.25-NS-20	VG-SST-2.25-SD-20	20
-	-	8
VG-SSTG-02-NS-10	VG-SSTG-02-SD-10	10
VG-SSTG-02-NS-12	VG-SSTG-02-SD-12	12
VG-SSTG-02-NS-20	-	20

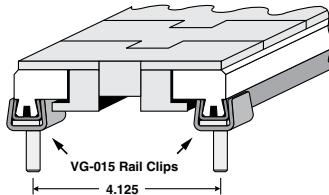
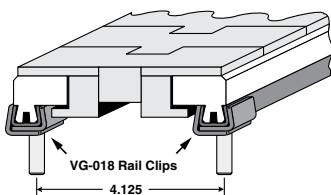

Tab Chain Guide mounting options

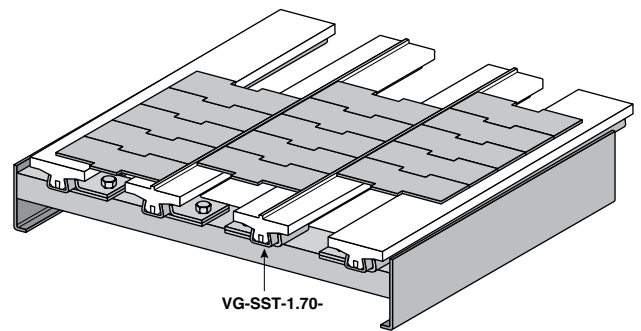
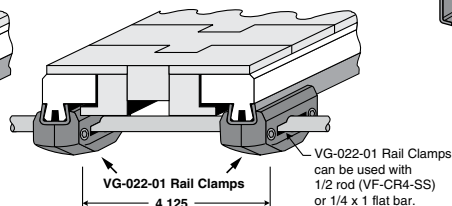
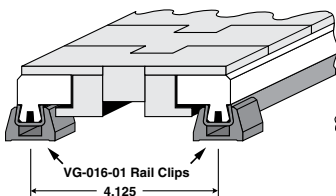



Chain Guide Wear Strip

Sprockets, Wear
Strips, Chain Guides

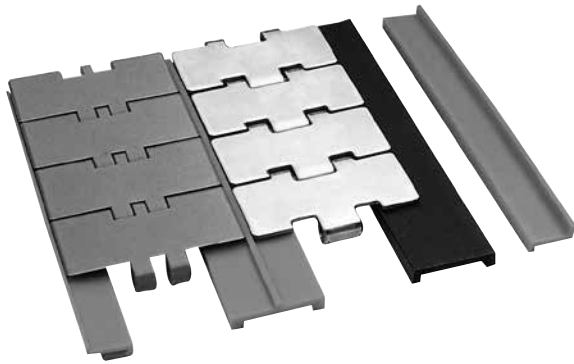

Chain Guide Wear Strip

These rails are commonly used as guide rails or support members under belting and table top chain.

- Low Friction Surface
- High Chemical Resistance
- No Liquid Absorption

19045

Material: UHMW or Nolu-S (NS)

Part Number	Color	Length
19045N	Black	6M (20 ft)
19045V	Green	6M (20 ft)
19045NS	Nolu-S	6M (20 ft)

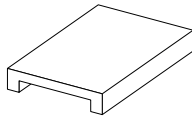
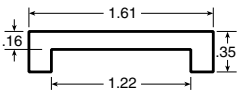

19067

Material: UHMW or Nolu-S (NS)

Part Number	Color	Length
19067N	Black	200 ft
19067V	Green	200 ft

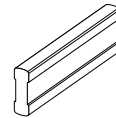
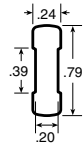

19006L

Material: UHMW

Part Number	Color	Length
19006LN	Black	60M (200 ft)
19006VN	Green	60M (200 ft)

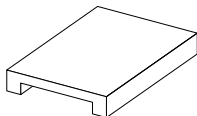
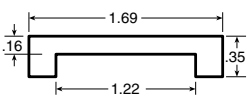

19006

Material: UHMW

Part Number	Color	Length
19006N	Black	60M (200 ft)
19006V	Green	60M (200 ft)

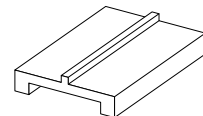
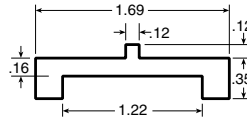

19071

Material: UHMW or Nolu-S (NS)

Part Number	Color	Length
19071	Black	6M (20 ft)
19070	Green	6M (20 ft)
19071NS	Nolu-S	6M (20 ft)

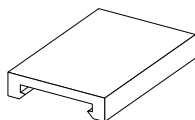
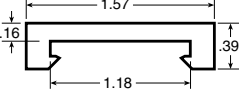

19073

Material: UHMW

Part Number	Color	Length
19073	Black	6M (20 ft)
19072	Green	6M (20 ft)

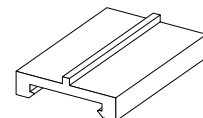
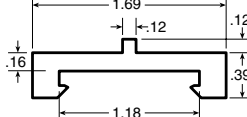



Sprockets, Wear Strips, Chain Guides

19080

Material: UHMW

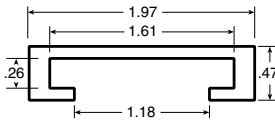

Part Number	Color	Length
19080N	Black	3M (10 ft)
19080NL	Black	6M (20 ft)
19080V	Green	3M (10 ft)
19080VL	Green	6M (20 ft)

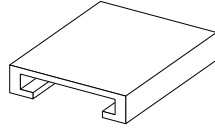

19053

Material: UHMW

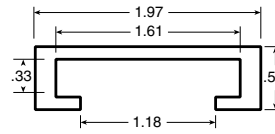

Part Number	Color	Length
19053N	Black	3M (10 ft)
19053NL	Black	6M (20 ft)
19053V	Green	3M (10 ft)
19053VL	Green	6M (20 ft)

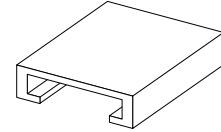

19081

Material: UHMW



Part Number	Color	Length
19081N	Black	3M (10 ft)
19081NL	Black	6M (20 ft)
19081V	Green	3M (10 ft)
19081VL	Green	6M (20 ft)

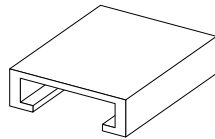

19004

Material: UHMW

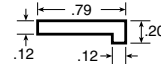

Available in Coils

Part Number	Color	Length
19004N	Black	200 ft
19004V	Green	200 ft

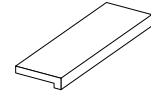

19003

Material: UHMW or Nolu-S (NS)

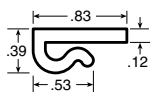

Available in Coils

Part Number	Color	Length
19003N	Black	200 ft
19003V	Green	200 ft
19003NS	Nolu-S	200 ft

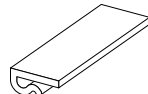

19007

Material: UHMW or Nolu-S (NS)

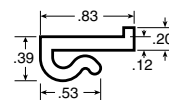

Available in Coils

Part Number	Color	Length
19007N	Black	200 ft
19007V	Green	200 ft
19007NS	Nolu-S	200 ft

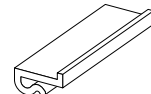

19005

Material: UHMW or Nolu-S (NS)

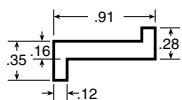

Available in Coils

Part Number	Color	Length
19005N	Black	200 ft
19005V	Green	200 ft
19005NS	Nolu-S	200 ft

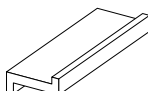

19001

Material: UHMW or Nolu-S (NS)

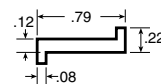

Available in Coils

Part Number	Color	Length
19001N	Black	200 ft
19001V	Green	200 ft
19001NS	Nolu-S	200 ft

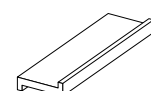



Sprockets, Wear Strips, Chain Guides

Chain Guide Wear Strip

The following metal channels can be used with the UHMW inserts listed in this group. These rails are commonly used as guide rails or support members under belting and table top chain. Mounting clamps and accessories designed for these metal channels are listed below.

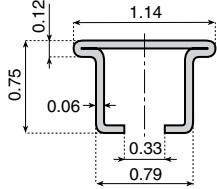

Material: Stainless steel

Part Number	Length
19048C	3M (9.84 ft.)
19048	6M (19.68ft.)

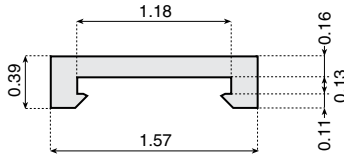

Material: UHMW

Part Number	Color	Length
19071	Black	6M (19.68ft.)
19070	Green	6M (19.68ft.)

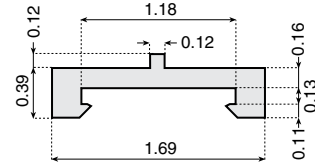

Material: UHMW

Part Number	Color	Length
19073	Black	6M (19.68ft.)
19072	Green	6M (19.68ft.)

Chain Guide Shoes for Channels

Shoes are used to guide chain between idler wheels and wear strip and must be fixed with M6 UNC screws.

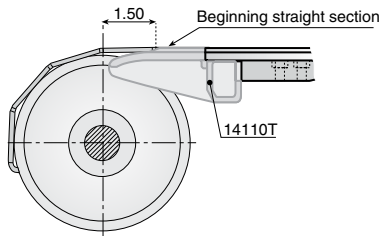

For use with stainless steel channel part number 19048

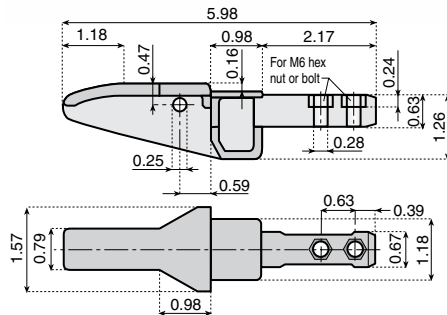

Material: Black Polyamide

Part Number	Hex Fastener Size
14110	M6

Clamps for channels

Use these clamps for mounting and splicing the metal channel supports. Uses 5/16", 1/4", M6 or M8 fastening hardware.

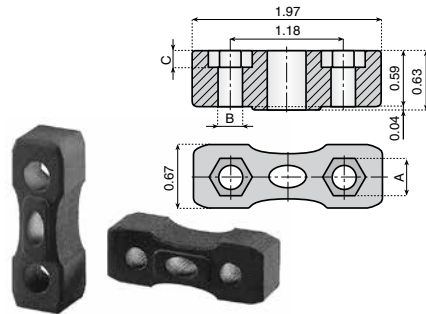
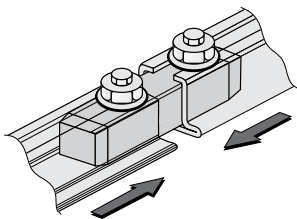

Material: Polyamide

Part Number	A	B	C	Hex Fastener Size
14111	.51	.32	.24	5/16 or M8

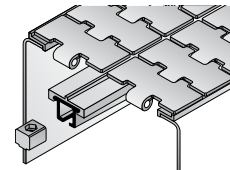

Material: Polyamide

Part Number	A	B	C	Hex Fastener Size
14109	.51	.32	.24	5/16 or M8



Chain Guide Shoes for Frame

Shoes are used to guide chain between idler wheels and wear strip and must be fixed with #10 or M5 UNC screws.

Sprockets, Wear Strips, Chain Guides

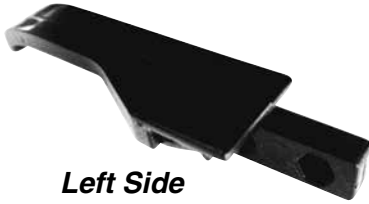

Left Side

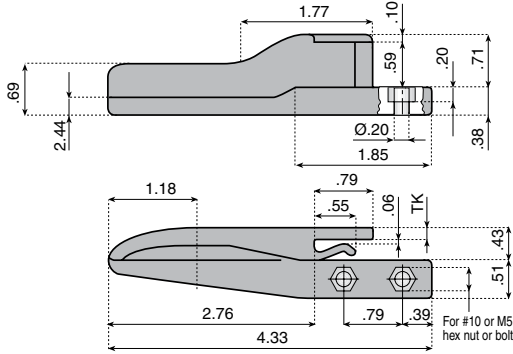

Material: Polyamide

Part Number	TK	Hex Fastener Size
14077N	.12 (3 mm)	#10 or M5
14088N	.16 (4 mm)	#10 or M5

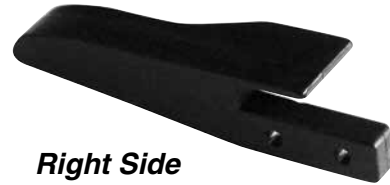

Right Side

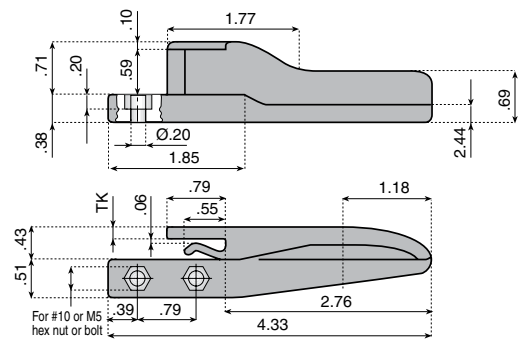

Material: Polyamide

Part Number	TK	Fastener
14076N	.12 (3 mm)	#10 or M5
14087N	.16 (4 mm)	#10 or M5

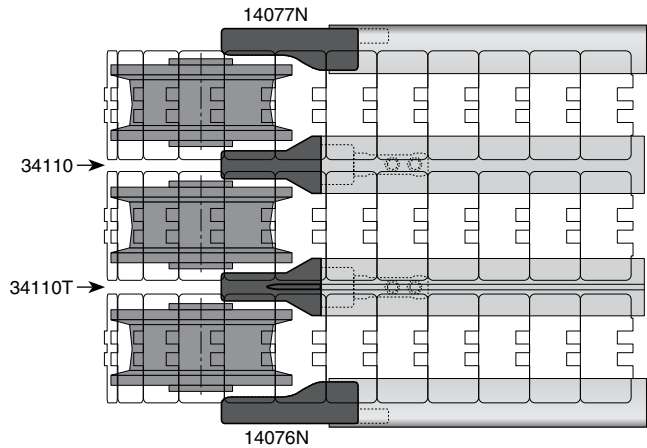
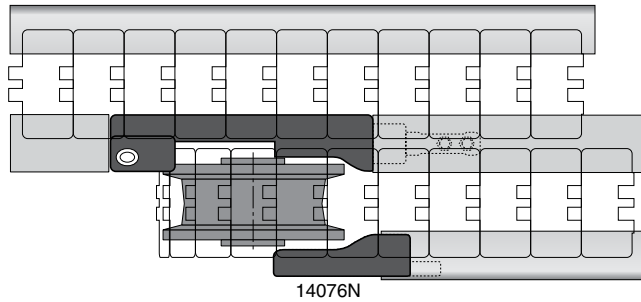



Rectangular Bar & Wear Strips

Machined product. Thicknesses range from 1/8" to 3" and widths from 1/2" to 6". The length is 10 feet. Other lengths are available upon request. Strip thickness tolerance is $\pm 10\%$ of the sheet and the width tolerance is $\pm 1/64$, with special tolerances available upon request. Rectangular wear strips can be fastened utilizing nylon drive rivets (VG-750). Applications for rectangular wear strips include: chain guide, wear strips, flat top chain contact guide, and dead plates.

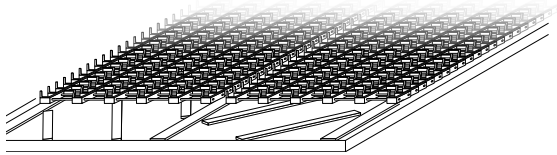
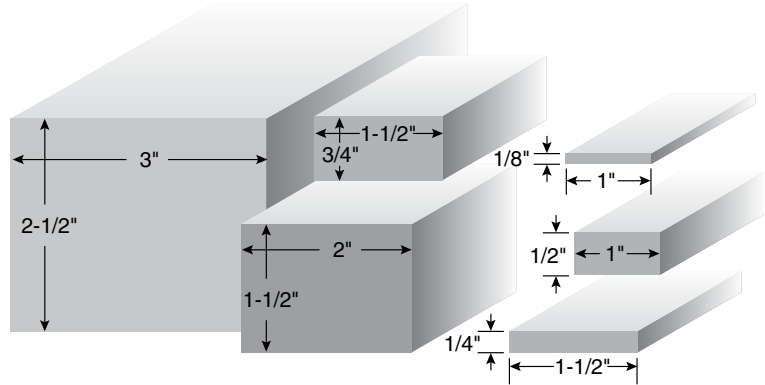

Part numbers in these tables are for Natural White UHMW-PE. To specify other materials, substitute the part number prefix "HS" with the following:

Nolu-S

"BR" for Nolu-BR (black)
A proprietary blend of UHMW resins. Maintains excellent chemical and corrosion resistance, while providing low friction, superior rigidity, and resistance to wear.

"SS" for Nolu-S (grey)
A blend of UHMW and other dry lubricants. Self-lubricating properties make it ideal for applications requiring reduced friction, noise reduction, and higher dry-running speeds.

Nolu-SR

"SR" for Nolu-SR (dark grey)
A much harder, longer wearing composition which is used in most high speed / high load applications. Proven to increase throughput, reduce jam ups, and extend product life.

Width inches	Thickness inches								
	1/8	3/16	1/4	5/16	3/8	1/2	5/8	3/4	7/8
1/2	HS-0208-10	HS-0308-10	HS-0408-10	-	HS-0608-10	HS-0808-10	-	-	-
3/4	HS-0212-10	HS-0312-10	HS-0412-10	HS-0512-10	HS-0612-10	HS-0812-10	HS-1012-10	HS-1212-10	-
1	HS-0216-10	HS-0316-10	HS-0416-10*	HS-0516-10	HS-0616-10	HS-0816-10	HS-1016-10	HS-1216-10	-
1-1/4	HS-0220-10	HS-0320-10	HS-0420-10*	HS-0520-10	HS-0620-10	HS-0820-10	HS-1020-10	HS-1220-10	HS-1420-10
1-1/2	HS-0224-10	HS-0324-10	HS-0424-10	HS-0524-10	HS-0624-10*	HS-0824-10*	HS-1024-10*	HS-1224-10*	-
1-3/4	HS-0228-10	HS-0328-10	HS-0428-10	-	HS-0628-10	HS-0828-10	-	HS-1228-10	-
2	HS-0232-10	HS-0332-10	HS-0432-10	HS-0532-10	HS-0632-10*	HS-0832-10*	HS-1032-10	HS-1232-10*	-
2-1/2	HS-0240-10	HS-0340-10	HS-0440-10	-	HS-0640-10	HS-0840-10	-	HS-1240-10	HS-1440-10
3	HS-0248-10	HS-0348-10	HS-0448-10	HS-0548-10	HS-0648-10	HS-0848-10	-	HS-1248-10	-
3-1/2	-	-	-	-	-	HS-1056-10	HS-1256-10	HS-1456-10	-
4	HS-0264-10	HS-0364-10	HS-0464-10	-	HS-0664-10	HS-0864-10	HS-1064-10	HS-1264-10	-

Width inches	Thickness inches							
	1	1-1/4	1-1/2	1-3/4	2	2-1/4	2-1/2	3
1	HS-1616-10	-	-	-	-	-	-	-
1-1/4	HS-1620-10	-	-	-	-	-	-	-
1-1/2	HS-1624-10	-	-	-	-	-	-	-
1-3/4	HS-1628-10	-	HS-2428-10	-	-	-	-	-
2	HS-1632-10	HS-2032-10	-	-	HS-3232-10	-	-	-
2-1/2	HS-1640-10	HS-2040-10	-	-	-	-	-	-
3	HS-1648-10	-	-	-	-	-	-	HS-4848-10
4	HS-1664-10	-	-	-	HS-3264-10	-	-	-
6	HS-1696-10	-	-	-	-	-	HS-4096-10	-

Wear strip with a thickness of 1/4 in. or less can be shipped coiled in cartons (UPS) or straight in tubes by truck.

* Longer continuous lengths available Contact System Plast Customer Service at 1-866-765-8744.



750

Drive Rivet

Used to attach wear strips to metal or plastic frames. Can be used for slotted holes with washer. Head can be mounted flush with thinner wear strips using standard countersink. Rivets wear at the same rate as wear strips, and will not cut into chains. Easily installed into .257 dia. (F drill), blind or thru hole. Max. continuous service temperature: 180° F. Bags of 100.

Protects your Chain and Belts!

Material: Polyamide rivet. Acetal pin.

Part Number	L	H	Grip (min.)	Grip (max.)
VG-750-10	.75	.111	.188	.5
VG-750-20	1.0	.111	.25	.75
VG-750-30	1.5	.111	.375	1.25

Drive Rivets sold in bags of 100.

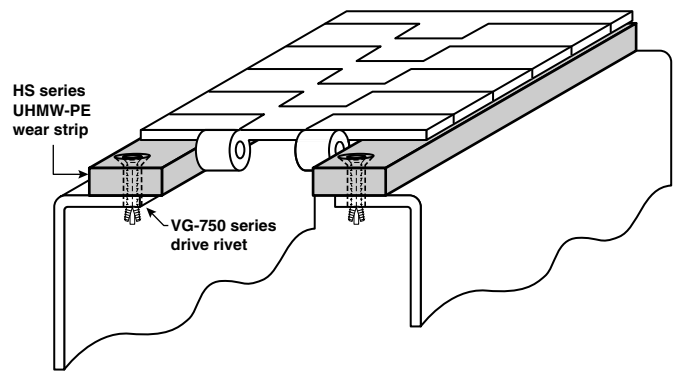
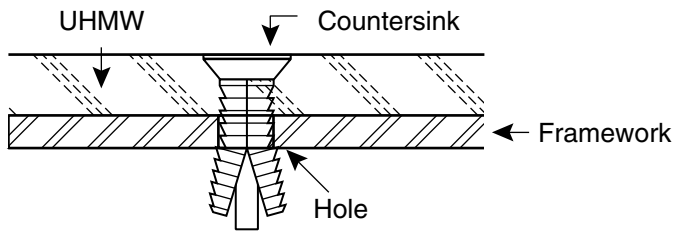
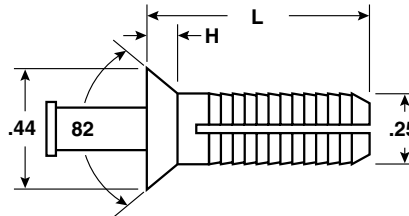

Sprockets, Wear Strips, Chain Guides

Two Piece Curved Wear Strip



Material: White UHMW (See below for other available materials.)

Sprockets, Wear Strips, Chain Guides

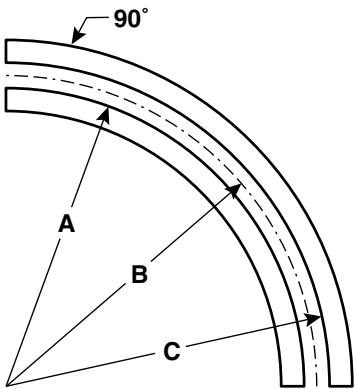

Bevel	A	B	C	Width	Thickness	Chain#	Chain Clearance	Used With	Manufacturer Recommended Width	Chain Rivet#	
VG-710-U18B3	17-3/16	18	18-13/16	1	3/8			879, 880, 881	1-5/8	K 3-1/4	VG-750-1
VG-710-U24B3	23-3/16	24	24-13/16	1	3/8				1-5/8	ALL	VG-750-1
VG-710-U30B3	29-3/16	30	30-13/16	1-1/2	3/8				1-5/8	ALL	VG-750-1
Rectangle											
VG-710-U18R3	17-1/8	18	18-7/8	1-1/2	3/8			879, 880, 881 Tab	1-3/4	K 3-1/4	VG-750-1
VG-710-U24R3	23-1/8	24	24-7/8	1-1/2	3/8				1-3/4	ALL	VG-750-1
VG-710-U30R3	29-1/8	30	30-7/8	1-1/2	3/8				1-3/4	ALL	VG-750-1
VG-710-U24R5	22-55/64	24	25-9/64	1-1/2	5/8			882 Tab, RR 882	2-9/32	ALL	VG-750-2
VG-710-U30R5	28-55/64	30	31-9/64	1-1/2	5/8				2-9/32	ALL	VG-750-2
VG-710-U18R6	17-5/16	18	18-11/16	1-1/2	3/4			1873, 1874, 3873, 4873, 4874	1-3/8	ALL	VG-750-3
VG-710-U24R6	23-5/16	24	24-11/16	1-1/2	3/4				1-3/8	ALL	VG-750-3

Custom Track Request Form

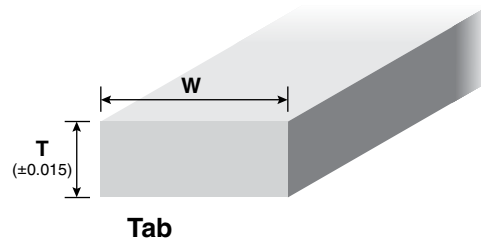
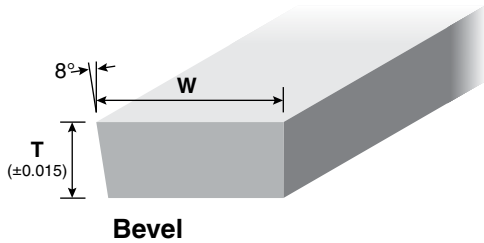

To order custom wear strips, specify the following things:

1. Material _____
2. Thickness of one curve (T) _____
3. Width of one curve (W) _____
4. Angle of curve (A) _____
6. Inside radius of inside curve (B) _____
7. Outside radius of inside curve (C) _____
5. Centerline radius (D) _____
8. Inside radius of outside curve (E) _____
9. Outside radius of outside curve (F) _____
10. Chain part being used _____

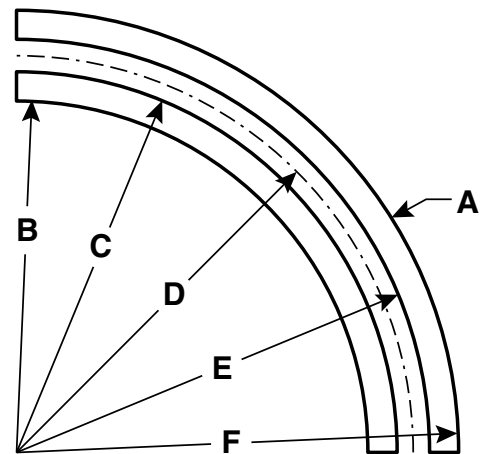

Fill out the information in the blanks above and fax to System Plast Customer Service toll free 866-447-6587.

Options available for most wear strips:

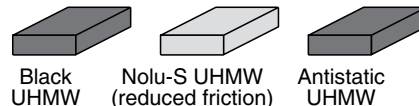



1234-SERP

Serpentine Chain Return

Multi-purpose serpentine chain return profile. Radiused top is ideal for minimal chain contact and reduced friction. If full contact is required, simply invert the profile and use the flat surface.

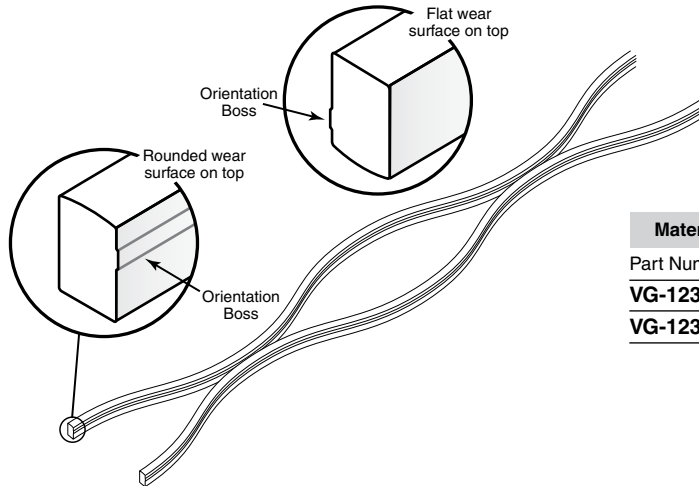
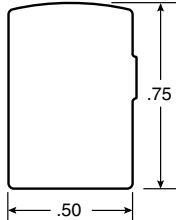

Material: UHMW.

Part Number	Length (ft.)
VG-1234-SERP-10.5	10.5
VG-1234-SERP-21	21

Sprockets, Wear Strips, Chain Guides

25100

Serpentine Chain Return

Multi-purpose serpentine chain return profile. Radiused top is ideal for minimal chain contact and reduced friction.

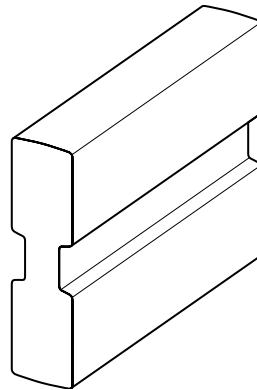
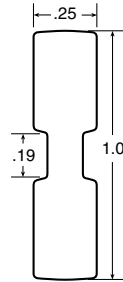

Material: UHMW.

Part Number	Length (ft.)
VG-PCR-25100-21	21
VG-PCR-25100-100	100



650

Chain Return Shoe

Radiused wear shoe for guiding chain or belting into return way. Single or multiple strand capabilities. Black polyamide shoe is designed for use with steel belts and chains. Gray polyethylene shoe is designed for use with plastic belts and chains.

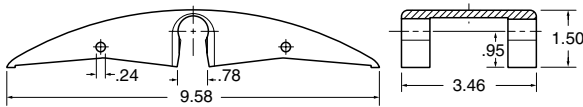

VG-650-A



Material: Black polyamide or gray polyethylene.

Part Number	Color/Material	Ø Bushing
VG-650-A	black/PA	None
VG-650-12	black/PA	1/2
VG-650-58	black/PA	5/8
VG-650PE-A	gray/PE	None
VG-650PE-12	gray/PE	1/2
VG-650PE-58	gray/PE	5/8

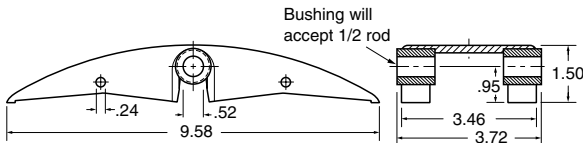

VG-650-12

Chain Return Shoes can be pinned together or gang mounted on common shaft for use with wide metal belts.

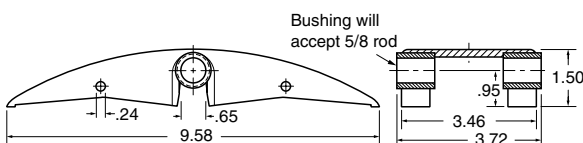

VG-650-58

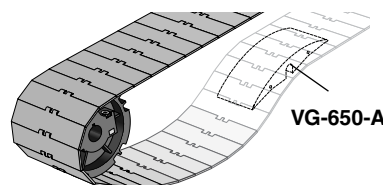

For new or retrofitting existing chain returns, consider the Valu Flex serpentine chain return system. It is a more cost effective, maintenance free and quieter alternative to roller returns. See the Valu Flex section on page 169 for more information.



Sprockets, Wear Strips, Chain Guides

MBG

Modular Conveyor Belt Side Guides

Aluminum and UHMW guide rail for use in guiding the sides of selected plastic modular conveyor belts through turns. Ultra-low friction. Top and bottom capture of belt. Custom factory bends can be ordered by contacting the System Plast Engineering Department. Available in 10 ft. lengths. Minimum radius 24" (inside edge). Replaceable UHMW strips.

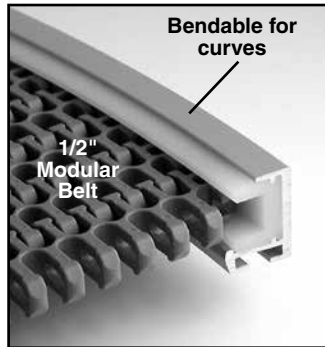
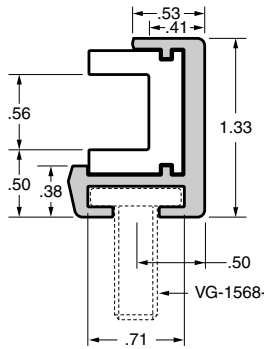

Material: UHMW insert and aluminum guides.

Part Number	Material	Length (ft.)
VG-MBG-50-NS-10	Nolu-S	10
Insert Replacements		
VG-PMBG-50-NS-10	Nolu-S	10
VG-PMBG-50-10	UHMW	10

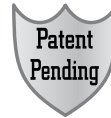

SBG

Conveyor Belt Side Guides and Wear Strips

Aluminum and UHMW guide rail for use in guiding the sides and supporting the middle of modular conveyor belts. Ultra-low friction bottom and side support of belt. Easily formed into curves with the Valu Guide Rail Bending Machine. Available in 10 ft. lengths. Minimum radius 18" (inside edge). Replaceable UHMW strips.

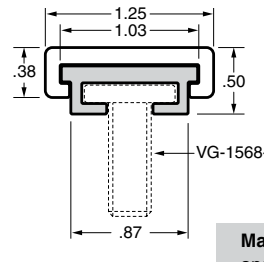
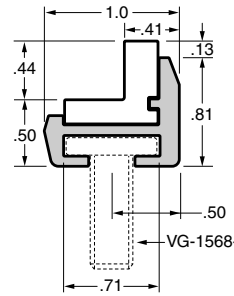
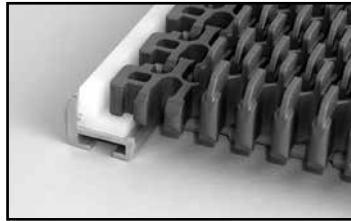
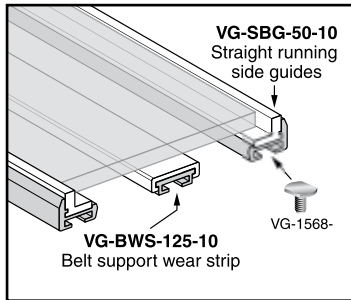

Material: UHMW insert and aluminum guides.

Part Number	Part Number	Length (ft.)
VG-SBG-50-10	VG-BWS-125-10	10

UHMW Insert Replacement	UHMW Insert Replacement	Length (ft.)
VG-PSBG-50-10	VG-PBWS-125-10	10

SSUT

Conveyor Belt Side Guides

Guide rail for use in guiding the sides of selected conveyor belts. Ultra-low friction. Easily formed into corners with the Valu Guide Rail Bending Machine.

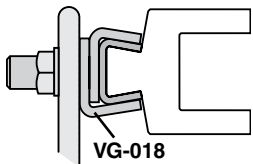
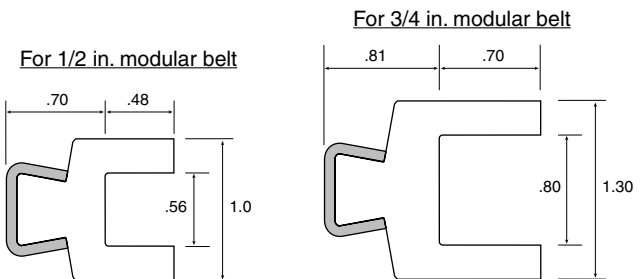
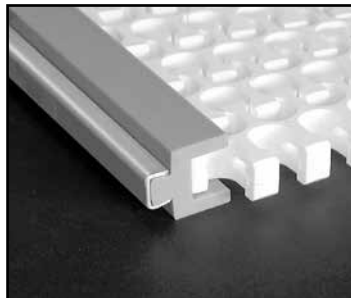

VG-SSUT Guide Rail can be mounted with Valu Guide rail clamps.

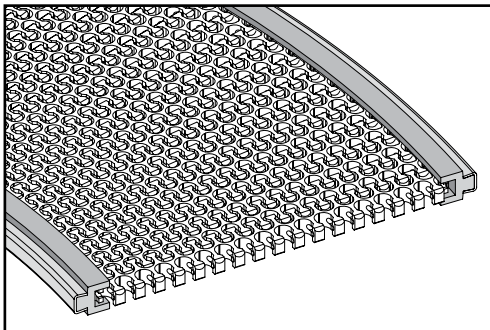

Material: Self-lubricating Nolu-S UHMW insert and stainless steel sheath, 14 gauge.

Part Number	Belt Thickness	Length (ft.)
VG-SSUT-1.00-S-10	1/2"	10
VG-SSUT-1.30-S-10	3/4"	10

Nolu-S is a proprietary alloy of food grade lubricants combined with UHMW. This creates a material which retains most of the properties of UHMW while significantly reducing friction. Nolu-S advantages include protection of expensive mating surfaces, lower noise levels and FDA and USDA approved ingredients.



Aluminum Channel Chain Guides

These aluminum extrusions with plastic wear strip inserts are designed to be roller chain guides with structural rigidity. The plastic inserts allow for the economical replacement of the chain guide wear surface without replacing the entire rail. These units will guide various ANSI roller chain sizes, depending upon the plastic insert used.

The insert is produced from Nolu-GR, a UHMW product preferred for typical chain guiding applications. Standard color is green. Also, UHMW cover profiles can be fitted onto some aluminum designs to act as a low friction, long wearing, guiding surface.

Sprockets, Wear Strips, Chain Guides

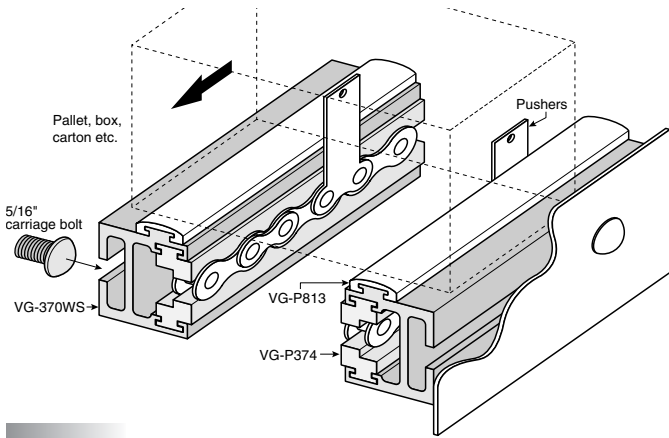

370

Chain Guide Assembly

Assembly includes aluminum extrusion and wear strips. These units can be configured to accept #40, #50 or #60 ANSI roller chains.

Material: Guide: aluminum. Insert: green UHMW.

8ft. Part Number	10ft. Part Number	12ft. Part Number	20ft. Part Number	A	B	C	Chain#
VG-370-40-8	VG-370-40-10	VG-370-40-12	VG-370-40-20	1.28	.29	.35	40
VG-370-50-8	VG-370-50-10	VG-370-50-12	VG-370-50-20	1.25	.35	.41	50
VG-370-60-8	VG-370-60-10	VG-370-60-12	VG-370-60-20	1.19	.47	.48	60

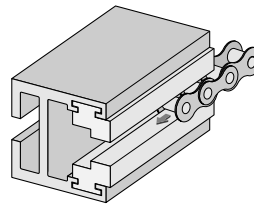

Note: Pinning of inserts at leading edge is recommended.

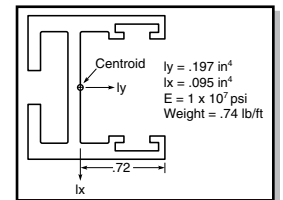
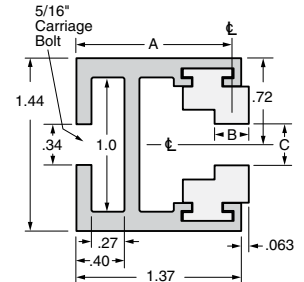

370WS

Chain Guide Assembly with Wear Strip

Assembly includes aluminum extrusion and wear strips. These units can be configured to accept #40, #50 or #60 ANSI roller chains.

Material: Guide: aluminum. Insert: green UHMW.

8ft. Part Number	10ft. Part Number	12ft. Part Number	20ft. Part Number	A	B	C	Chain#
VG-370WS-40-8	VG-370WS-40-10	VG-370WS-40-12	-	1.28	.29	.35	40
VG-370WS-50-8	VG-370WS-50-10	VG-370WS-50-12	VG-370WS-50-20	1.25	.35	.41	50
VG-370WS-60-8	VG-370WS-60-10	VG-370WS-60-12	VG-370WS-60-20	1.19	.47	.48	60

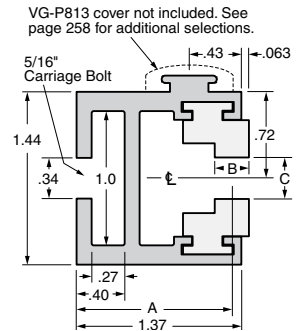
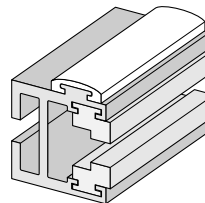

340-80

Chain Guide Assembly

Assembly includes aluminum extrusion and wear strips. These units can be configured to accept #80 ANSI roller chains.

Material: Guide: aluminum. Insert: green UHMW.

8ft. Part Number	10ft. Part Number	12ft. Part Number	20ft. Part Number	Chain#
-	VG-340-80-10	-	VG-340-80-20	80

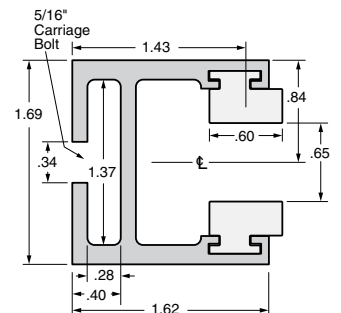
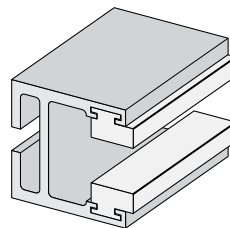



Sprockets, Wear Strips, Chain Guides

340-PC

Chain Guide Assembly

Assembly includes aluminum extrusion and wear strips. Special chain track designed for use in can making systems to guide #60 high speed extended pin chain.

Material: Guide: aluminum. Insert: green UHMW.

8ft. Part Number	10ft. Part Number	Chain#
VG-340-PC-60-8	VG-340-PC-60-10	60

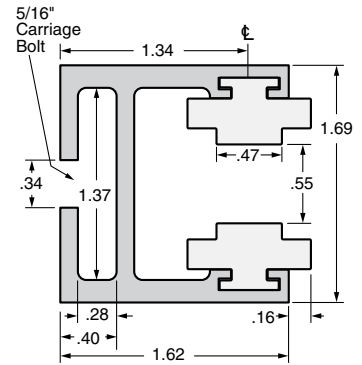
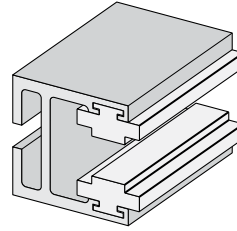

360

Double Chain Guide Assembly

Assembly includes aluminum extrusion and wear strips. These units can be configured to accept #40, #50 or #60 ANSI roller chains.

Material: Guide: aluminum. Insert: green UHMW.

10ft. Part Number	20ft. Part Number	A	B	C	Chain#
VG-360-40-10	VG-360-40-20	.86	.29	.35	40
VG-360-50-10	-	.83	.35	.41	50
VG-360-60-10	VG-360-60-20	.77	.47	.48	60

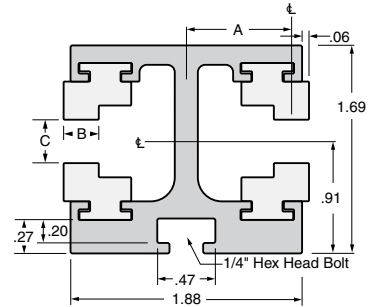
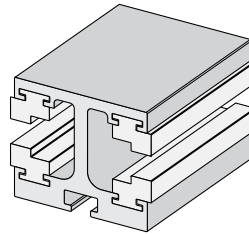

380

Vertical Chain Guide Assembly with Wear Strip

Assembly includes aluminum extrusion and wear strips for roller chain. Outer wear strip attachment is not included. These units can be configured to accept #50 or #60 ANSI roller chains.

Material: Guide: aluminum. Insert: green UHMW.

8ft. Part Number	10ft. Part Number	12ft. Part Number	20ft. Part Number	A	B	C	Chain#
VG-380-40-8	VG-380-40-10	VG-380-40-12	VG-380-40-20	.84	.29	.35	40
VG-380-50-8	VG-380-50-10	VG-380-50-12	VG-380-50-20	.81	.35	.41	50
VG-380-60-8	VG-380-60-10	VG-380-60-12	VG-380-60-20	.75	.47	.48	60

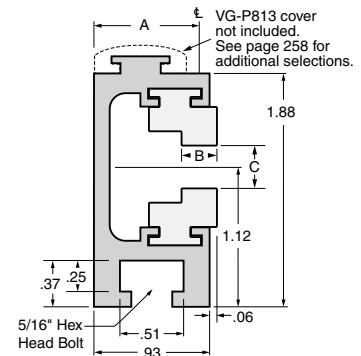
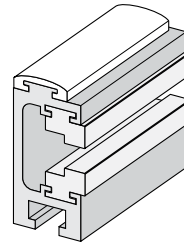

P300 series

UHMW Inserts

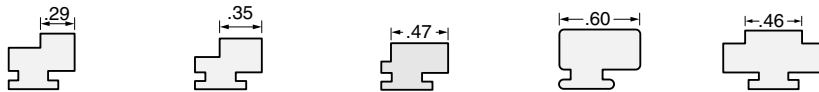

Material: Green UHMW.

Part Number	Part Number	Part Number	Part Number	Part Number	Length (ft.)
VG-P374-10	VG-P375-10	VG-P376-10	VG-P379-10	VG-P378-10	10
VG-P374-20	VG-P375-20	VG-P376-20	VG-P379-20	-	20

Guides #40 and #2040 ANSI chain. Used with 360, 370, 370WS & 380 series aluminum channel.

Guides #50 and #2050 ANSI chain. Used with 360, 370, 370WS & 380 series aluminum channel.

Guides #60 and #2060 ANSI chain. Used with 360, 370, 370WS & 380 series aluminum channel.

Guides #80 and #2080 ANSI chain. Used with 340 series aluminum channel.

Guides #60 and #2060 ANSI chain. Used with 340-PC series aluminum channel.

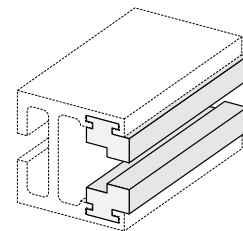

Shipping Information: UHMW covers and inserts are typically shipped straight in tubes. 8' lengths can be shipped UPS. Standard 10' or 20' lengths are shipped by common carrier. Selected items can be coiled into carts for more convenient shipping.



Roller Chain Guide Rail



Material: Sheath is 304 stainless steel or galvanized steel, 14 gauge. Insert is UHMW.

#40

Chain Guide

Wear strip and guide for #40 ANSI single roller chains.

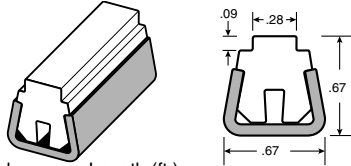

Stainless	Galvanized	Length (ft.)
VG-SSCG-#40-8	VG-GSCG-#40-8	8
VG-SSCG-#40-10	VG-GSCG-#40-10	10
VG-SSCG-#40-12	VG-GSCG-#40-12	12
VG-SSCG-#40-20	VG-GSCG-#40-20	20

#50

Chain Guide

Wear strip and guide for #50 ANSI single roller chains.

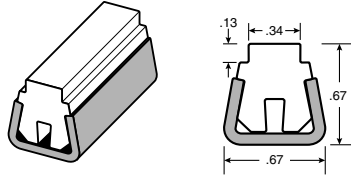

Stainless	Galvanized	Length (ft.)
VG-SSCG-#50-8	VG-GSCG-#50-8	8
VG-SSCG-#50-10	VG-GSCG-#50-10	10
VG-SSCG-#50-12	-	12
VG-SSCG-#50-20	VG-GSCG-#50-20	20

#60

Chain Guide

Wear strip and guide for #60 ANSI single roller chains. Can also be used as side rail or wear strip when a wider surface contact is required.

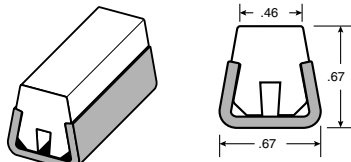

Stainless	Galvanized	Length (ft.)
VG-SSF-8	VG-GSF-8	8
VG-SSF-10	VG-GSF-10	10
VG-SSF-12	VG-GSF-12	12
VG-SSF-20	VG-GSF-20	20

#80

Chain Guide

Wear strip and guide for #80 ANSI single roller chains.

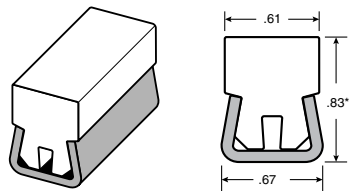

Stainless	Galvanized	Length (ft.)
VG-SSCG-#80-8	VG-GSCG-#80-8	8
VG-SSCG-#80-10	VG-GSCG-#80-10	10
VG-SSCG-#80-12	VG-GSCG-#80-12	12
VG-SSCG-#80-20	VG-GSCG-#80-20	20

*Tolerance on height is ±0.025.

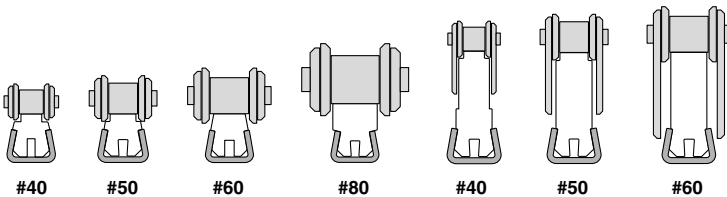

#40

Extended Chain Guide

Wear strip and guide for #40 ANSI single roller chains.

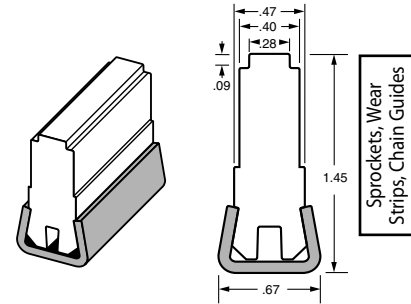

Stainless	Galvanized	Length (ft.)
VG-SSECG-#40-8	VG-GSECG-#40-8	8
VG-SSECG-#40-10	VG-GSECG-#40-10	10
VG-SSECG-#40-12	VG-GSECG-#40-12	12
VG-SSECG-#40-20	VG-GSECG-#40-20	20

#50

Extended Chain Guide

Wear strip and guide for #50 ANSI single roller chains.

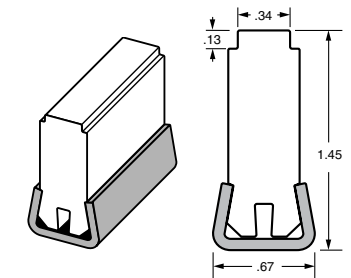

Stainless	Galvanized	Length (ft.)
VG-SSECG-#50-8	VG-GSECG-#50-8	8
VG-SSECG-#50-10	VG-GSECG-#50-10	10
VG-SSECG-#50-12	-	12
VG-SSECG-#50-20	-	20

#60

Extended Chain Guide

Wear strip and guide for #60 ANSI single roller chains.

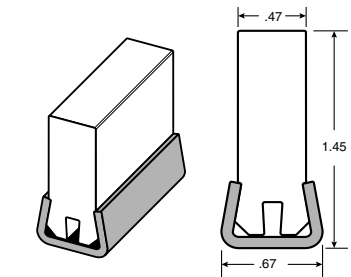

Stainless	Galvanized	Length (ft.)
VG-SSECG-#60-8	VG-GSECG-#60-8	8
VG-SSECG-#60-10	VG-GSECG-#60-10	10
VG-SSECG-#60-12	VG-GSECG-#60-12	12
VG-SSECG-#60-20	VG-GSECG-#60-20	20

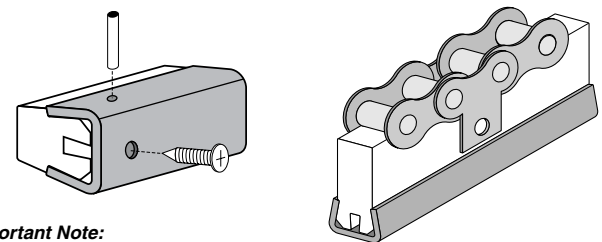

Important Note:

When Valu Guide Rail is used as a wear strip, the UHMW insert should be fastened to the metal sheath at the leading end of the rail. Using a sheet metal screw through the back of the sheath or a heavy wire pin from the side should be adequate. This will prevent the insert from sliding within the sheath in the event the chain accidentally catches on a leading edge. This also allows for thermal expansion and contraction of the UHMW insert.

SYSTEM PLAST™

Roller Chain Guides



Chain Track

Standard plastic tracks are primarily used to guide and support ANSI double pitch chain in packaging and drag chain conveying systems. Experience has shown that the best way to distribute the load and increase capacity is to support these chains on a flat edge of the side plates. These UHMW based products provide low friction surfaces with outstanding wear resistance when the load is distributed in this manner.

Width Tolerance is ± 0.015 "

Height Tolerance is ± 0.1 "

Length Tolerance is ± 1.0 "

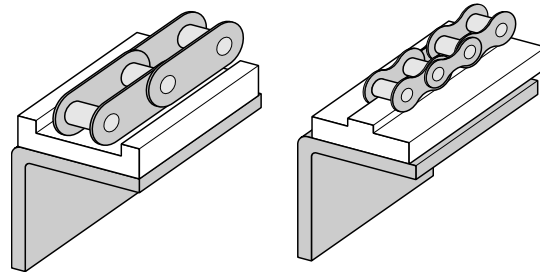

Sprockets, Wear Strips, Chain Guides

HA

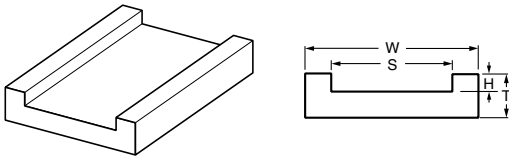

Material: White UHMW or Nolu-S.

UHMW	Nolu-S	T	W	H	S	Chain Size	Length (ft.)
HA-2040-5	-	5/16	1-1/4	1/8	7/8	40	5
HA-2040-10	SA-2040-10	5/16	1-1/4	1/8	7/8	40	10
HA-2050-5	-	3/8	1-1/4	5/32	1	50	5
HA-2050-10	SA-2050-10	3/8	1-1/4	5/32	1	50	10
HA-2060-5	-	3/8	1-1/2	3/16	1-1/4	60	5
HA-2060-10	SA-2060-10	3/8	1-1/2	3/16	1-1/4	60	10
HA-2080-5	-	1/2	2	1/4	1-9/16	80	5
HA-2080-10	SA-2080-10	1/2	2	1/4	1-9/16	80	10
HA-2100-10	SA-2100-10	5/8	2-1/4	5/16	1-7/8	100	10
HA-2120-5	-	5/8	2-3/4	3/8	2-1/4	120	5
HA-2120-10	SA-2120-10	5/8	2-3/4	3/8	2-1/4	120	10

HC

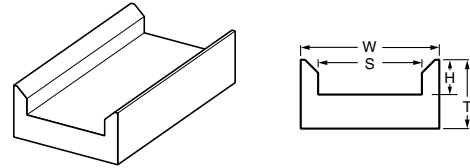

Material: White UHMW or Nolu-S.

UHMW	Nolu-S	T	W	H	S	Chain Size	Length (ft.)
HC-2040-5	-	1/2	1	1/4	3/4	40	5
HC-2040-10	SC-2040-10	1/2	1	1/4	3/4	40	10
HC-2050-10	-	1/2	1-1/4	9/32	1	50	10
HC-2060-5	-	5/8	1-1/2	5/16	1-1/4	60	5
HC-2060-10	SC-2060-10	5/8	1-1/2	5/16	1-1/4	60	10
HC-2080-5	-	5/8	2	3/8	1-1/2	80	5
HC-2080-10	SC-2080-10	5/8	2	3/8	1-1/2	80	10
-HC-2100-10	-	3/4	2-1/4	7/16	1-13/16	100	10
HC-2120-10	-	7/8	3	9/16	2-1/4	120	10

HE

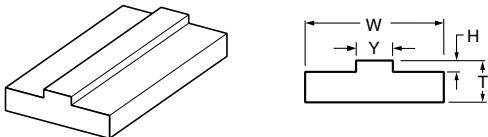

Material: White UHMW or Nolu-S.

UHMW	Nolu-S	T	W	H	S	Chain Size	Length (ft.)
HE-2040-5	-	5/16	1	.08	1/4	40	10
HE-2040-10	SE-2040-10	5/16	1	.08	1/4	40	10
HE-2050-5	SE-2050-5	5/16	1-1/4	.10	5/16	50	10
HE-2050-10	SE-2050-10	5/16	1-1/4	.10	5/16	50	10
HE-2060-5	SE-2060-5	5/16	1-1/4	.115	7/16	60	10
HE-2060-10	SE-2060-10	5/16	1-1/4	.115	7/16	60	10
HE-2080-5	SE-2080-5	3/8	1-1/2	.13	9/16	80	10
HE-2080-10	SE-2080-10	3/8	1-1/2	.13	9/16	80	10
HE-2100-10	SE-2100-10	1/2	2	.21	11/16	100	10

HG

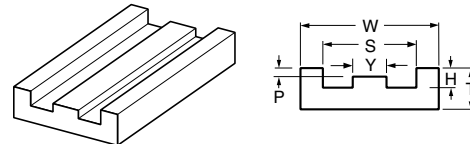

Material: White UHMW or Nolu-S.

UHMW	Nolu-S	T	W	H	P	S	Y	Chain Size	Length (ft.)
HG-2040-5	-	5/16	1	.14	.08	11/16	1/4	40	5
HG-2040-10	-	5/16	1	.14	.08	11/16	1/4	40	10
HG-2050-5	SG-2050-5	3/8	1-1/4	3/16	.10	13/16	5/16	50	5
HG-2050-10	SG-2050-10	3/8	1-1/4	3/16	.10	13/16	5/16	50	10
HG-2060-5	SG-2060-5	1/2	1-1/2	.213	.115	1-1/8	7/16	60	5
HG-2060-10	SG-2060-10	1/2	1-1/2	.213	.115	1-1/8	7/16	60	10
HG-2080-5	SG-2080-5	1/2	2	1/4	.13	1-7/16	9/16	80	5
HG-2080-10	SG-2080-10	1/2	2	1/4	.13	1-7/16	9/16	80	10

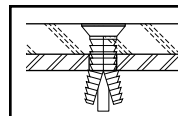

See page 185 for VG-750 drive rivet fastening method.



HGCP

Cable Pulley with Metal Sleeve Bushing

Made from a special grade of UHMW polymer to produce a tough, abrasion resistant, low friction pulley that provides long corrosion free service with a significant reduction in noise levels. Custom designs available. Shown is a standard 3/8" cable pulley with different mounting bolt diameters. Pulleys are supplied with a stainless steel powdered metal sleeve to form an axle after assembly. A nut, bolt and washer can be supplied if needed.

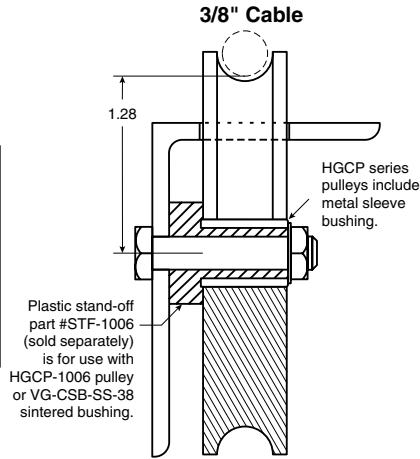
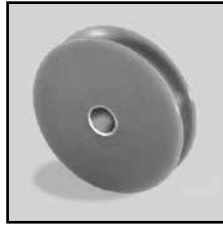

Material: Green UHMW.

Part Number	Ø Bolt
HGCP-1004	1/4
HGCP-1005	5/16
HGCP-1006	3/8

Sprockets, Wear Strips, Chain Guides

CS

Cable Pulley Only

Corrosion resistant and long lasting design offers quiet and smooth operation. An ideal replacement for all types of cable conveyors. The pulleys are available with a variety of stainless steel bushings.

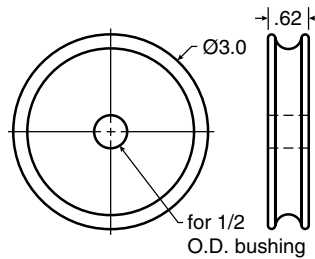

Material: Green UHMW.

Part Number	Ø Bolt
VG-CS-3.0	

CSFB

Machined Bushing

1/4 bolts only. Snap rings included.

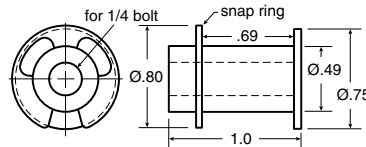
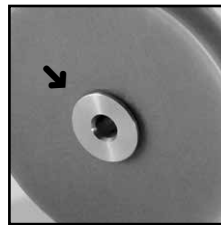
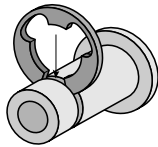

Material: 303 stainless steel.

Part Number	Ø Bolt
VG-CSFB-SS-14	1/4

CSB

Sintered Bushing

VG-CSB-SS-38 is for use with flanged spacer.

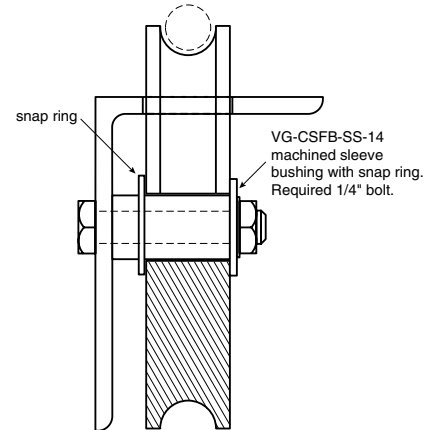
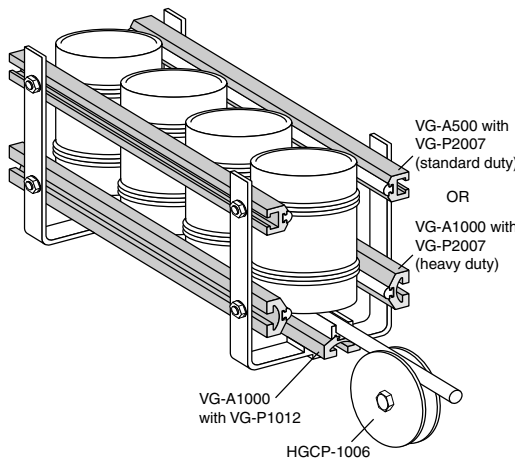
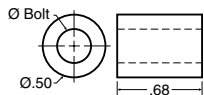
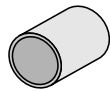

Material: Sintered stainless steel.

Part Number	Ø Bolt
VG-CSB-SS-14	1/4
VG-CSB-SS-516	5/16
VG-CSB-SS-38	3/8

See page 194 for more information on cable track profiles.

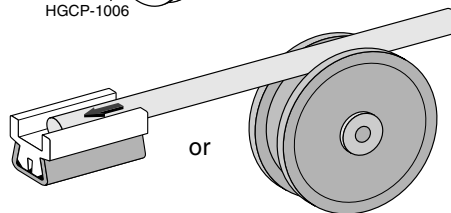



Additional Cable Pulley Sizes

Made from a special grade of UHMW polymer to produce a tough, abrasion resistant, low friction pulley that provides long corrosion free service with a significant reduction in noise levels. A stainless steel powdered metal sleeve to form an axle after assembly is supplied. Pulleys can also be designed to your specifications by contacting our engineering department.

Material: Green UHMW.

1/2" Cable Part Number	A-size V-belt Part Number	Ø Bolt
HGCP-12-1004	-	1/4
HGCP-12-1005	HGCP-AV-1005	5/16
HGCP-12-1006	HGCP-AV-1006	3/8

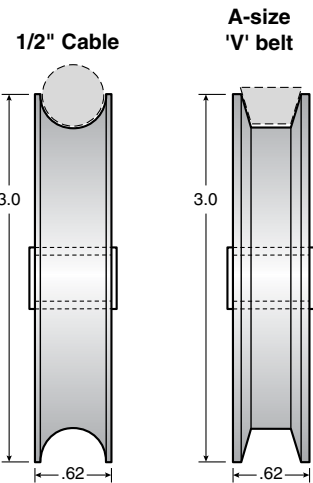

Sprockets, Wear Strips, Chain Guides

VBG-.61

V-Belt Guide

Wear strip and guide for "A" section Vee belts.

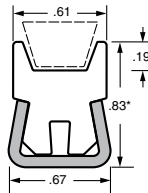
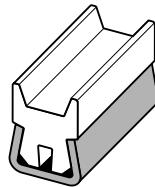

Material: Sheath is 304 stainless steel or galvanized steel, 14 gauge. Insert is UHMW.

Steel Sheath		Length **(ft.)
Stainless	Galvanized	
VG-SSVBG-.61A-8	VG-GSVBG-.61A-8	8
VG-SSVBG-.61A-10	VG-GSVBG-.61A-10	10
VG-SSVBG-.61A-12	-	12
VG-SSVBG-.61A-20	VG-GSVBG-.61A-20	20

VBG-.75

V-Belt Guide

Wear strip and guide for "B" section Vee belts.

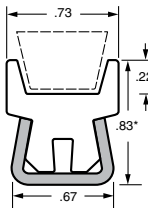
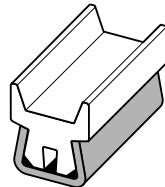

VG-SSVBG-.75B-8	VG-GSVBG-.75B-8	8
VG-SSVBG-.75B-10	VG-GSVBG-.75B-10	10
VG-SSVBG-.75B-12	VG-GSVBG-.75B-12	12
VG-SSVBG-.75B-20	VG-GSVBG-.75B-20	20

CT

Cable Track

A positive guide and wear surface for 3/8 dia. cable track runs. Replaces the cable pulleys on the working side of the cable.

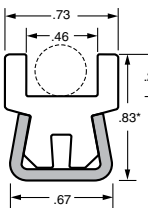
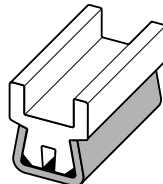

VG-SSCT-8	VG-GSCT-8	8
VG-SSCT-10	VG-GSCT-10	10
VG-SSCT-12	VG-GSCT-12	12
VG-SSCT-20	VG-GSCT-20	20

RBG

Round Belt Guide

Support for 8mm diameter cable. Provides positive tracking for cables used in conveying light containers.

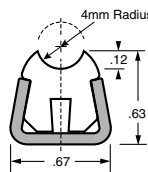
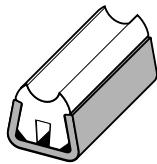

VG-SSRBG-8	VG-GSRBG-8	8
VG-SSRBG-10	-	10
VG-SSRBG-12	VG-GSRBG-12	12
VG-SSRBG-20	VG-GSRBG-20	20

*Tolerance on height is ±0.025.

**4, 5 and 6 ft. lengths are also available. Other lengths can be cut to order.

Important Note:

When Valu Guide Rail is used as a wear strip, the UHMW insert should be fastened to the metal sheath at the leading end of the rail. Using a sheet metal screw through the back of the sheath or a heavy wire pin from the side should be adequate. This will prevent the insert from sliding within the sheath in the event the chain accidentally catches on a leading edge. This also allows for thermal expansion and contraction of the UHMW insert.

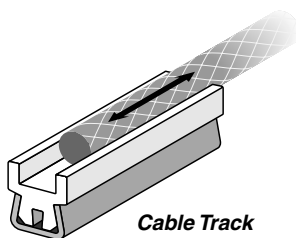
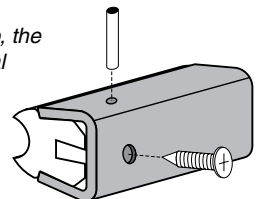

Cable Track

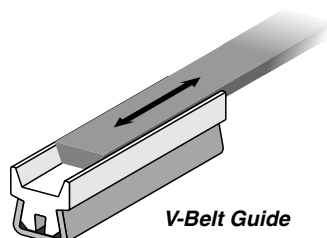

V-Belt Guide



Cable Guides

The following aluminum extrusions can be used with the UHMW insert listed in this group. These rails are commonly used as cable guides for conveying. Part number VG-A500 fastens with a 5/16 hex head bolt, and part number VG-A1000 fastens with a 3/8 carriage bolt (bolts not included).

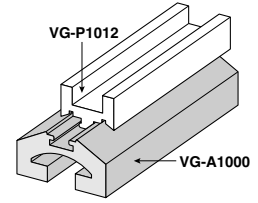
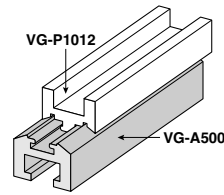

Sprockets, Wear Strips, Chain Guides

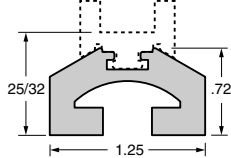
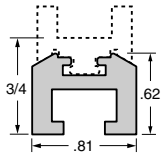

Material: Aluminum.

Length (ft.)

VG-A500-10	VG-A1000-10	10
VG-A500-20	VG-A1000-20	20

Also shown on page 257.

Also shown on page 257.

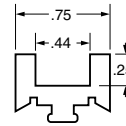

Material: UHMW.

Length (ft.)

VG-P1012-10	10
VG-P1012-20	20

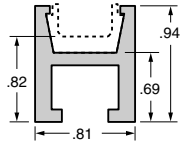

Material: Aluminum.

Length (ft.)

VG-A1315-10	10
VG-A1315-20	20

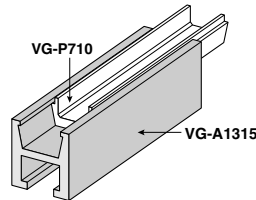

Material: UHMW.

Length (ft.)

VG-P710-10	10
VG-P710-20	20

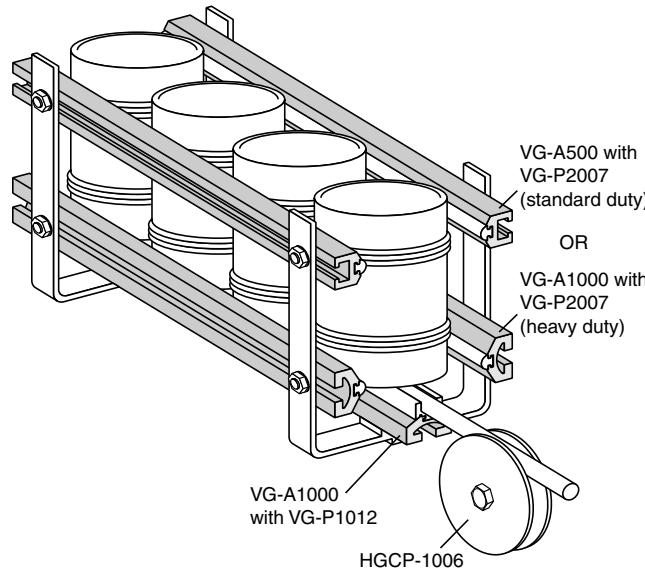



Sprockets, Wear Strips, Chain Guides

VGT

Standard UHMW Coiled Strip

Available in standard 50ft. rolls. Longer lengths available. Fast UPS shipping. Easy to cut, no saw required. Easy to install. Rivets can be used with 1/8" material.

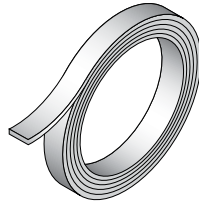

Adhesive Backed UHMW Coiled Strip

Allows strip to be quickly and easily mounted.

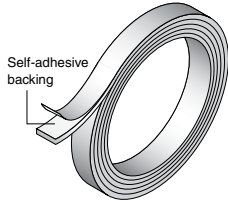

Material: UHMW or Nolu-S UHMW in 50 ft. coils

Standard coiled strip	Adhesive backed coiled strip	Thickness (in.)	Width (in.)
VGT-0612-050	VGT-0612PS-050	1/16	3/4
VGT-0616-050	VGT-0616PS-050	1/16	1
VGT-0624-050	VGT-0624PS-050	1/16	1-1/2
VGT-0632-050	VGT-0632PS-050	1/16	2
VGT-1212-050	VGT-1212PS-050	1/8	3/4
VGT-1216-050	VGT-1216PS-050	1/8	1
VGT-1224-050	VGT-1224PS-050	1/8	1-1/2
VGT-1232-050	VGT-1232PS-050	1/8	2

Note: Maximum thickness for all UHMW coiled strips is 1/8". *Other sizes available as special order.

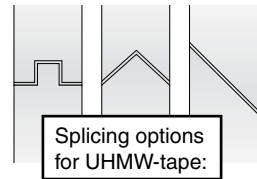

Splicing options for UHMW-tape:

VGRU

Roll UHMW

Available in standard 50 ft. rolls. Longer lengths and other materials available. Rivets can be used with 1/8" material.

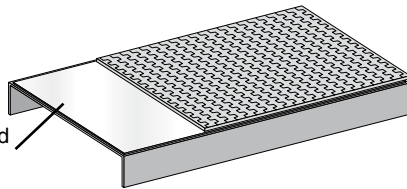
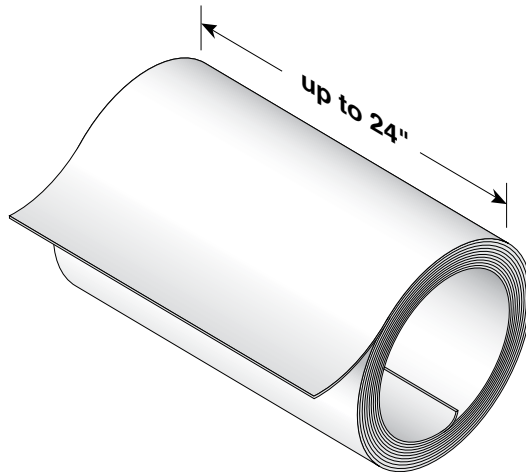

Can be used as a wear bed for wide conveyor belting.

Material: UHMW or Nolu-S UHMW in 50 ft. coils

Standard UHMW	Thickness (in.)	Width (in.)
VGRU-116-6-50	1/16	6
VGRU-116-12-50	1/16	12
VGRU-116-18-50	1/16	18

Can be used as a chute or trough liner.

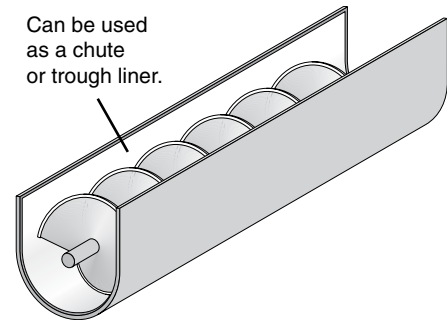

Recommendations for Pressure Sensitive Tape Application

Proper surface preparation is the most critical element in the laminating operation. Adhesives used with pressure sensitive tapes are subject to breakdown when in contact with contaminated surfaces. A conscientious effort on the part of the installer is required. The substrate should be as smooth and clean as possible. To prepare the substrate for bonding, wipe with a clean cloth containing a totally evaporating solvent, such as lacquer thinner. Turn the cloth frequently to avoid recontaminating the surface. When clean and dry, apply the pressure sensitive adhesive system. A j-roller should be used to assure pressure is applied for proper adhesion. Once the release liner has been removed from the tape, avoid contact with the adhesion. Clean hands are also recommended. NOTE: Must be applied at a temperature above 50 degrees F.

Removing or Replacing UHMW

Pry up a corner of UHMW with a screwdriver and peel plastic strip up using a pliers or vise grip. Remove residual adhesive using a clean rag and solvent such as lacquer thinner or permissible solvent. Since the adhesive has a .5 mil mylar liner, some mild scraping or scouring may be required. The remaining adhesive can be removed by wiping with a rag and solvent. Make sure surface is clean and dry before applying new UHMW.

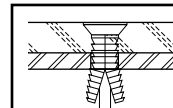

See page 185 for VG-750 drive rivet fastening method.

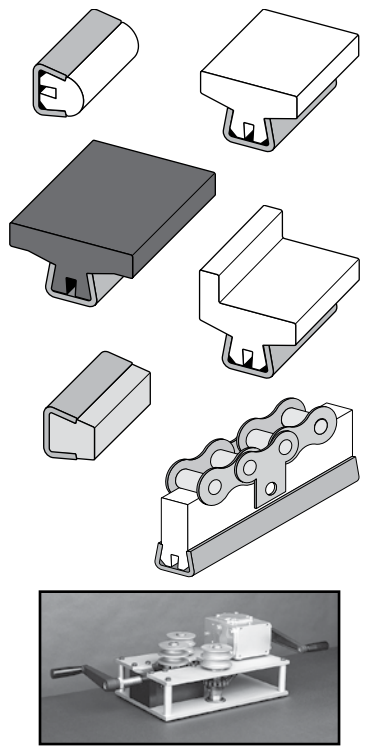
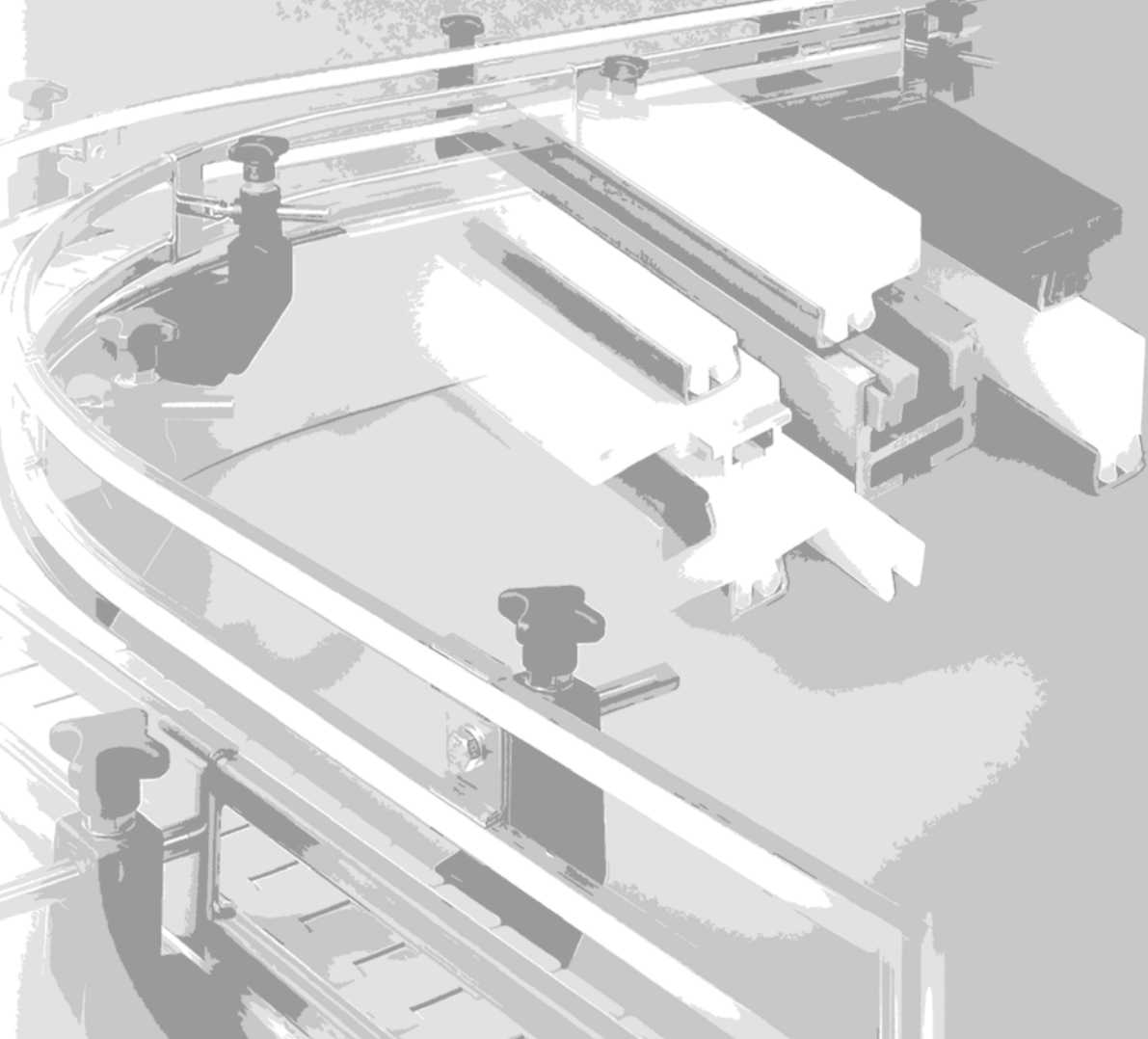

Valu Guide
Rails Page 200
 Side guide rails
 Tee guide rails
 Chain guide rails
 Specialty guide rail
 PolyGlide
 Lane dividers
 Bending Machine

GUIDE RAILS AND HARDWARE

Section 3

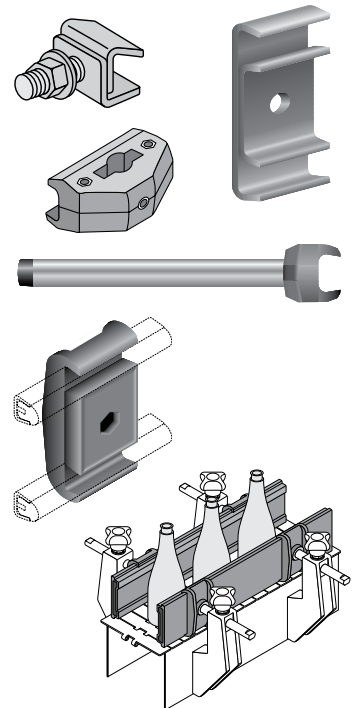
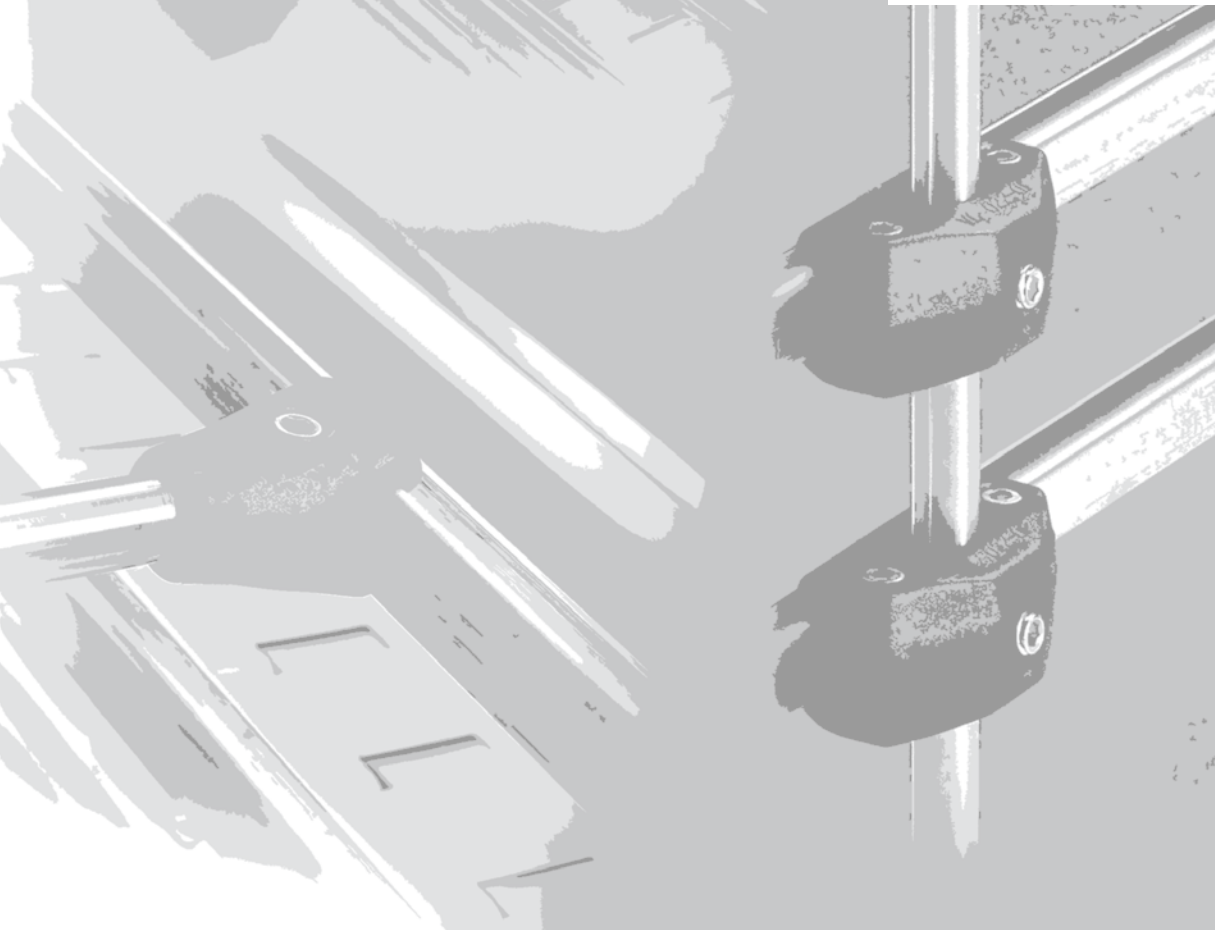

Guide Rail
Hardware Page 224
 Single rail clamps
 Double rail clamps
 Rail splicing
 Rail clips
 Clamps with rods
 Rod ends

VALU GUIDE®

The Original, Long Life Sanitary Guide Rail

Valu Guide rail incorporates two outstanding materials: stainless steel and UHMW. The 14 ga. stainless steel sheath provides rigid streamlined support for heavy loads at any speed, plus a solid connecting point for holding the rail in place with clamps and brackets.

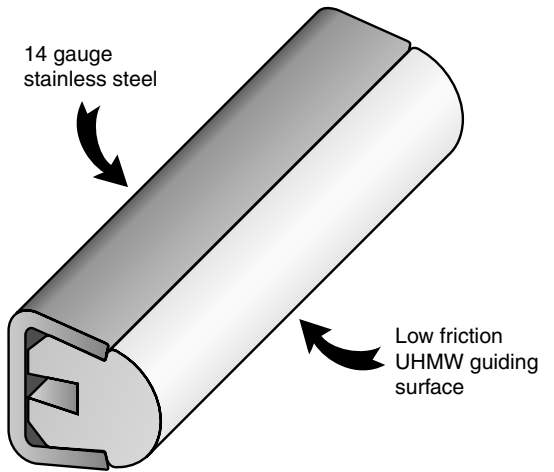

The UHMW guiding surface is available in a wide selection of shapes. The very low friction characteristics of UHMW allow containers to move at high speed with a minimum of drag, container damage, and noise.

Many Valu Guide materials are approved by the FDA and accepted for use in USDA inspected facilities.



Guide Rails and Hardware



Valu Guide Sheaths

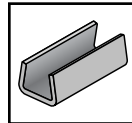

Stainless Steel -

Valu Guide rail sheaths are typically stainless steel, used for its excellent resistance to corrosion and long lasting attractive appearance. 316 stainless steel is available for even greater corrosion protection. Galvanized steel can be ordered as an economical alternative to stainless steel.

Valu Guide Inserts

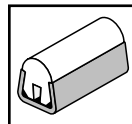

Natural UHMW - Translucent white.

Valu Guide's manufacturing process allows the use of UHMW without additives or other processing chemicals. The result is a material that resists abrasion better, is more color stable (less prone to yellowing) and of uniform consistency.

Optional Valu Guide Inserts

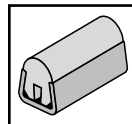

Nolu-S UHMW - Battleship grey color.

A proprietary alloy of food grade lubricants combined with UHMW. This creates a material which retains most of the properties of UHMW while significantly reducing friction. Nolu-S advantages include protection of expensive mating surfaces, lower noise levels, and FDA and USDA approved ingredients.

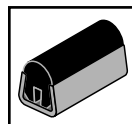

Static Dissipating UHMW - Black color.

Valu Guide's special formulation retains the low friction and wear characteristics of UHMW while effectively reducing problems caused by static. See page 212 for specifications.

Typical Properties of Valu Guide Rail

	Unit	UHMW	Stainless Steel
Density	lb/in ³	.034	.283
Tensile Strength	PSI	4,000 - 5,500	70,000
Tensile Modulus of Elasticity	PSI	90,000	29,000,000
Dynamic Coefficient of Friction (dry vs. steel)		.09 - .12	-
Coefficient of Linear Thermal Expansion	in/in/°F	7.2 x 10 ⁻⁵	9.6 x 10 ⁻⁶
Continuous Service Air Temperature (*max.)	°F	160/180	-

Typical Valu Guide Component Applications

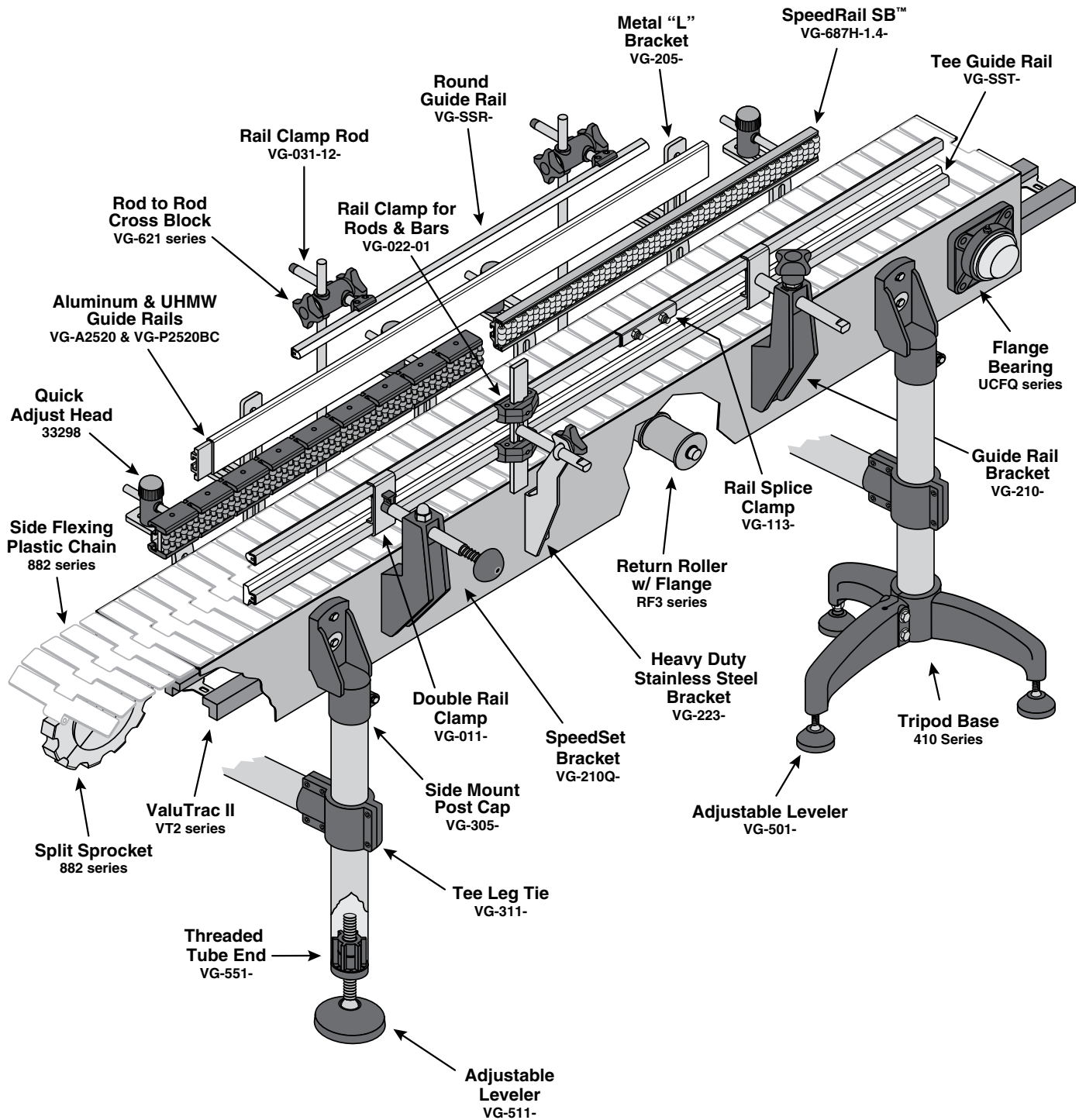

R

Round Rail

General purpose side rail for minimum container contact.

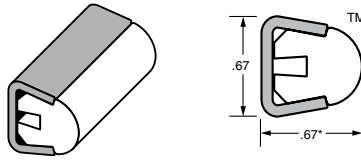

F

Flat Rail

Side rail or wear strip when a wider surface contact is required. Can also be used as a chain guide for #60 roller chain. Also see page 206.

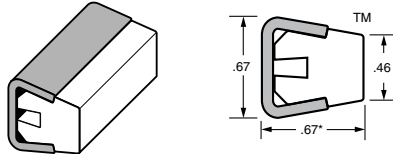

M

Modified Rail

Side rail for soft containers where minimum contact is required in order to prevent damage during higher side loading conditions.

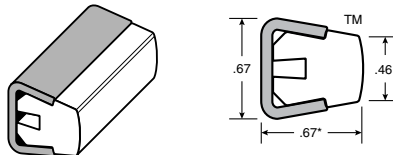

WF

Wide Flat Rail

Side rail or wear strip. Can be used in combination with the above rails when a greater contact area is required.

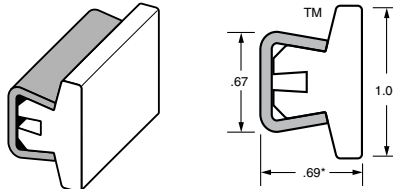

WF-1.25

Wide Flat Rail

Side rail or wear strip. Can be used in combination with the above rails when a greater contact area is required.

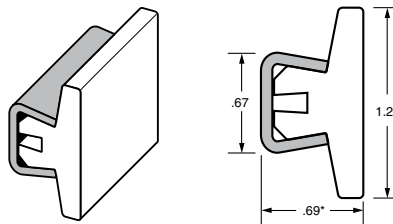

MT

Modified Tee Rail

Side rail when narrow surface contact or control is necessary following application of a label.

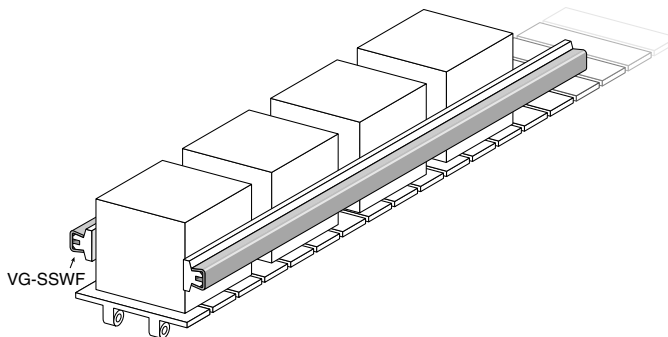
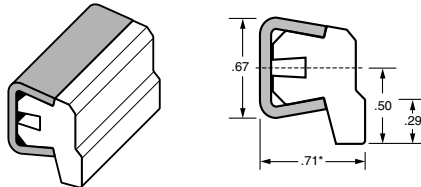

Natural White UHMW

Material: UHMW Insert and stainless steel or galvanized steel sheath, 14 gauge.

Stainless	Galvanized	Length (ft.)
VG-SSR-8	VG-GSR-8	8
VG-SSR-10	VG-GSR-10	10
VG-SSR-12	VG-GSR-12	12
VG-SSR-20	VG-GSR-20	20

VG-SSF-8	VG-GSF-8	8
VG-SSF-10	VG-GSF-10	10
VG-SSF-12	VG-GSF-12	12
VG-SSF-20	VG-GSF-20	20

VG-SSM-8	VG-GSM-8	8
VG-SSM-10	VG-GSM-10	10
VG-SSM-12	VG-GSM-12	12
VG-SSM-20	VG-GSM-20	20

VG-SSWF-8	VG-GSWF-8	8
VG-SSWF-10	VG-GSWF-10	10
VG-SSWF-12	VG-GSWF-12	12
VG-SSWF-20	VG-GSWF-20	20

VG-SSWF-1.25-8	VG-GSWF-1.25-8	8
VG-SSWF-1.25-10	VG-GSWF-1.25-10	10
VG-SSWF-1.25-12	-	12
VG-SSWF-1.25-20	VG-GSWF-1.25-20	20

VG-SSMT-8	VG-GSMT-8	8
VG-SSMT-10	VG-GSMT-10	10
VG-SSMT-12	VG-GSMT-12	12
VG-SSMT-20	VG-GSMT-20	20

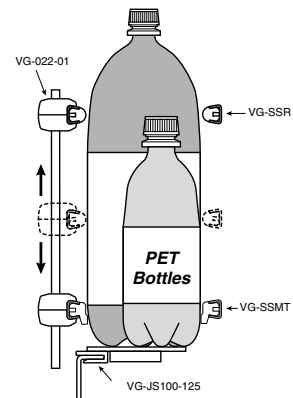

Guide Rail with Premium UHMW Materials



Gray Nolu-S

Self lubricating Nolu-S UHMW insert and stainless steel sheath, 14 gauge.



Static Dissipating

Static dissipating UHMW insert and stainless steel sheath, 14 gauge.

		Length (ft.)
VG-SSR-NS-8	VG-SSR-SD-8	8
VG-SSR-NS-10	VG-SSR-SD-10	10
VG-SSR-NS-12	VG-SSR-SD-12	12
VG-SSR-NS-20	VG-SSR-SD-20	20
VG-SSF-NS-8	VG-SSF-SD-8	8
VG-SSF-NS-10	VG-SSF-SD-10	10
VG-SSF-NS-12	VG-SSF-SD-12	12
VG-SSF-NS-20	VG-SSF-SD-20	20
VG-SSM-NS-8	VG-SSM-SD-8	8
VG-SSM-NS-10	VG-SSM-SD-10	10
VG-SSM-NS-12	VG-SSM-SD-12	12
VG-SSM-NS-20	VG-SSM-SD-20	20
VG-SSWF-NS-8	-	8
VG-SSWF-NS-10	-	10
VG-SSWF-NS-12	-	12
VG-SSWF-NS-20	-	20
-	-	8
-	VG-SSWF-1.25-SD-10	10
-	-	12
-	VG-SSWF-1.25-SD-20	20
-	VG-SSMT-SD-8	8
-	VG-SSMT-SD-10	10
-	VG-SSMT-SD-12	12
-	VG-SSMT-SD-20	20

*Tolerance on height is ± 0.025 .
 AISI 316 stainless steel are available on a special order basis.

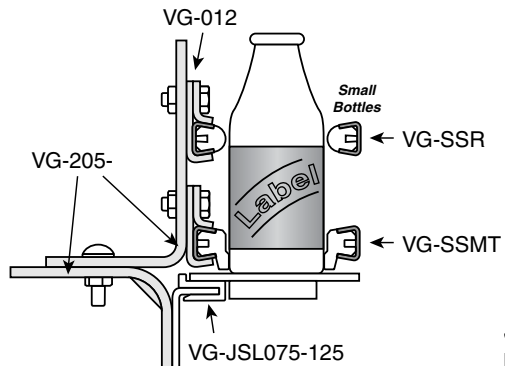
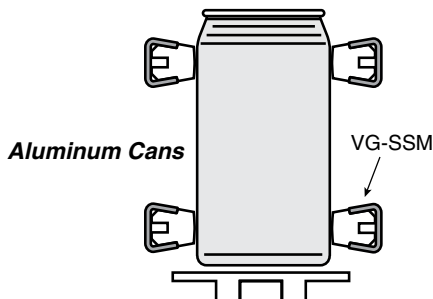

Guide Rails and Hardware

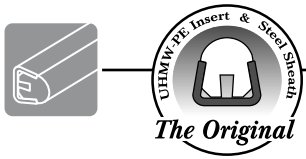

Tee Guide Rail

Valu Guide Tee Guide Rail can be used as a side rail when a larger container contact area is required or as a wear strip for wide metal or plastic belting and slat top chain. These rail shapes are also shown with conveyor chain wear beds on page 176-179.



Natural White UHMW

Material: UHMW Insert and stainless steel or galvanized steel sheath, 14 gauge.

Stainless	Galvanized	Length (ft.)
VG-SST-.75-8	VG-GST-.75-8	8
VG-SST-.75-10	VG-GST-.75-10	10
VG-SST-.75-12	VG-GST-.75-12	12
VG-SST-.75-20	VG-GST-.75-20	20

VG-SST-1.00-8	VG-GST-1.00-8	8
VG-SST-1.00-10	VG-GST-1.00-10	10
VG-SST-1.00-12	VG-GST-1.00-12	12
VG-SST-1.00-20	VG-GST-1.00-20	20

VG-SST-1.25-8	VG-GST-1.25-8	8
VG-SST-1.25-10	VG-GST-1.25-10	10
VG-SST-1.25-12	VG-GST-1.25-12	12
VG-SST-1.25-20	VG-GST-1.25-20	20

VG-SST-1.60-8	VG-GST-1.60-8	8
VG-SST-1.60-10	VG-GST-1.60-10	10
VG-SST-1.60-12	VG-GST-1.60-12	12
VG-SST-1.60-20	VG-GST-1.60-20	20

VG-SST-2.25-8	VG-GST-2.25-8	8
VG-SST-2.25-10	VG-GST-2.25-10	10
VG-SST-2.25-12	VG-GST-2.25-12	12
VG-SST-2.25-20	VG-GST-2.25-20	20

T-.75

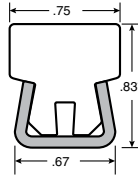
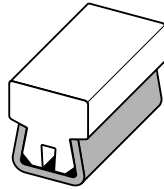

T-1.00

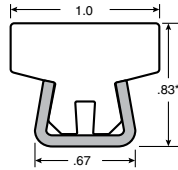
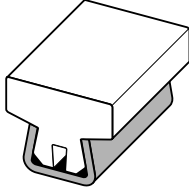

T-1.25

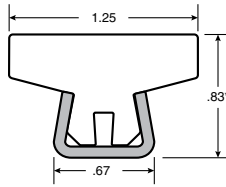
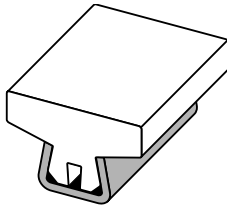

T-1.60

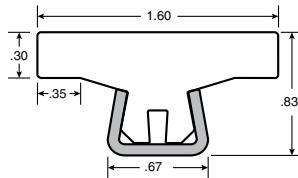
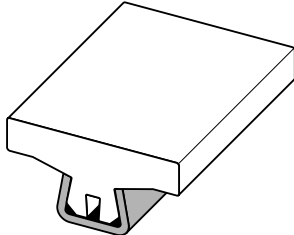

T-2.25

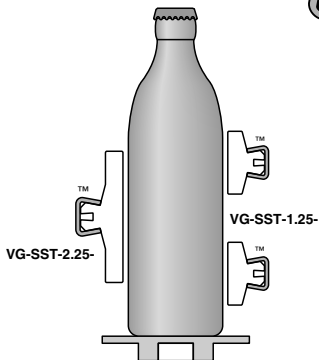
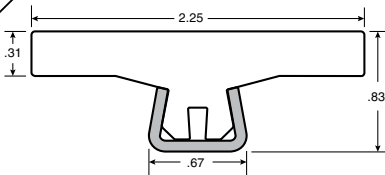
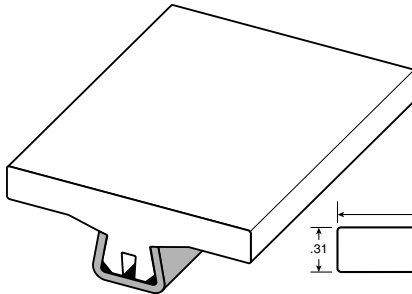

Valu Guide rail can be used to form a wear bed grid for metal or plastic belts. See page 218 for more details.

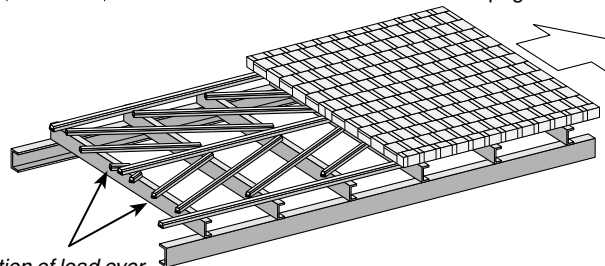

Note: For even distribution of load over width of belt, use the same type of guide rail through out your application.

Tee Guide Rail with Premium UHMW Materials



Gray Nolu-S

Self lubricating Nolu-S UHMW insert and stainless steel sheath, 14 gauge.



Static Dissipating

Static dissipating UHMW insert and stainless steel sheath, 14 gauge.

		Length (ft.)
VG-SST-.75-NS-8	VG-SST-.75-SD-8	8
VG-SST-.75-NS-10	VG-SST-.75-SD-10	10
VG-SST-.75-NS-12	VG-SST-.75-SD-12	12
VG-SST-.75-NS-20	VG-SST-.75-SD-20	20
-		
VG-SST-1.00-NS-8	VG-SST-1.00-SD-8	8
VG-SST-1.00-NS-10	VG-SST-1.00-SD-10	10
VG-SST-1.00-NS-12	VG-SST-1.00-SD-12	12
VG-SST-1.00-NS-20	VG-SST-1.00-SD-20	20
-		
VG-SST-1.25-NS-8	VG-SST-1.25-SD-8	8
VG-SST-1.25-NS-10	VG-SST-1.25-SD-10	10
VG-SST-1.25-NS-12	VG-SST-1.25-SD-12	12
VG-SST-1.25-NS-20	VG-SST-1.25-SD-20	20
-		
VG-SST-1.60-NS-8	VG-SST-1.60-SD-8	8
VG-SST-1.60-NS-10	VG-SST-1.60-SD-10	10
VG-SST-1.60-NS-12	VG-SST-1.60-SD-12	12
VG-SST-1.60-NS-20	VG-SST-1.60-SD-20	20
-		
VG-SST-2.25-NS-8	VG-SST-2.25-SD-8	8
VG-SST-2.25-NS-10	VG-SST-2.25-SD-10	10
VG-SST-2.25-NS-12	VG-SST-2.25-SD-12	12
VG-SST-2.25-NS-20	VG-SST-2.25-SD-20	20

*Tolerance on height is ± 0.02 .
 AISI 316 stainless steel are available on a special order basis.

Guide Rails and Hardware

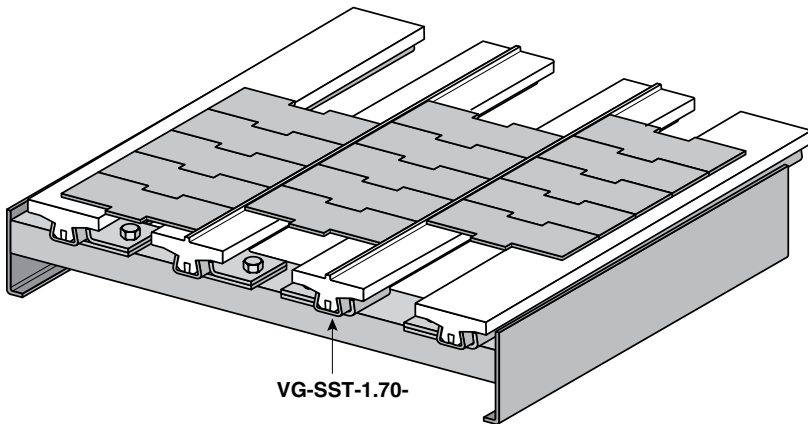

Important Note:

When Valu Guide Rail is used as a wear strip, the UHMW insert should be fastened to the metal sheath at the leading end of the rail. Using a sheet metal screw through the back of the sheath or a heavy wire pin from the side should be adequate. This will prevent the insert from sliding within the sheath in the event the chain accidentally catches on a leading edge. This also allows for thermal expansion and contraction of the UHMW insert.

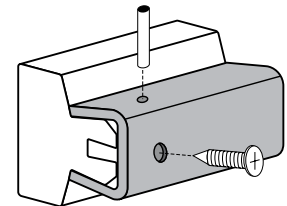

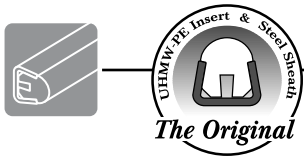

Tee Guide Rail



Natural White UHMW

Material: UHMW Insert and stainless steel or galvanized steel sheath, 14 gauge.

T-1.70

Ribbed Tee

Used as wear strip and support assembly for multi-lane 3/4 in. slat top chain.

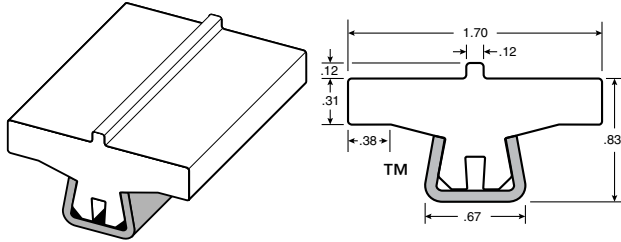

Stainless	Galvanized	Length (ft.)
VG-SST-1.70-8	VG-GST-1.70-8	8
VG-SST-1.70-10	VG-GST-1.70-10	10
VG-SST-1.70-12	-	12
VG-SST-1.70-20	-	20

LT

Eil Tee

Wear strip and side guide for modular wire belts. Provides positive edge tracking and a low friction, abrasion resistant support.

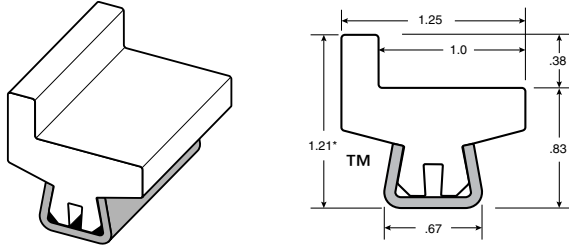

VG-SSLT-1.0x.38-8	VG-GSLT-1.0x.38-8	8
VG-SSLT-1.0x.38-10	VG-GSLT-1.0x.38-10	10
VG-SSLT-1.0x.38-12	VG-GSLT-1.0x.38-12	12
VG-SSLT-1.0x.38-20	VG-GSLT-1.0x.38-20	20

NG

Neck Guide

Side rail used as auxiliary support for PET beverage bottles on both table top and air conveyors.

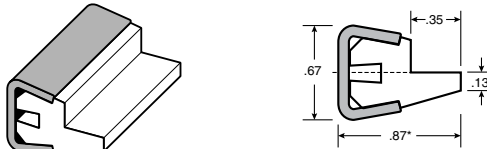

VG-SSNG-8	-	8
VG-SSNG-10	-	10
VG-SSNG-12	-	12
VG-SSNG-20	-	20

TG-02

Tab Chain Guide

Economical alternative to other chain guiding systems. For use with 882-4-1/2 and 882-LBP-3-3/4 style chains.

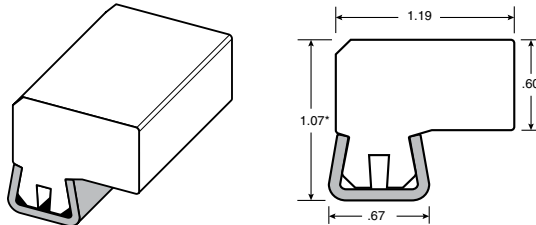

VG-SSTG-02-8	VG-GSTG-02-8	8
VG-SSTG-02-10	VG-GSTG-02-10	10
VG-SSTG-02-12	VG-GSTG-02-12	12
VG-SSTG-02-20	VG-GSTG-02-20	20

TG-03

Tab Chain Guide

Economical alternative to other chain guiding systems. For use with 882-4-1/2 and 882-LBP-3-3/4 style chains.

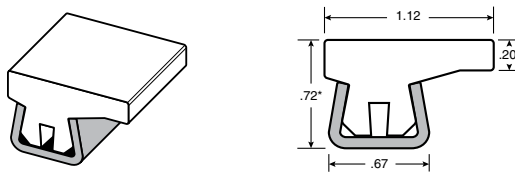

VG-SSTG-03-8	-	8
VG-SSTG-03-10	-	10
VG-SSTG-03-12	-	12
VG-SSTG-03-20	-	20

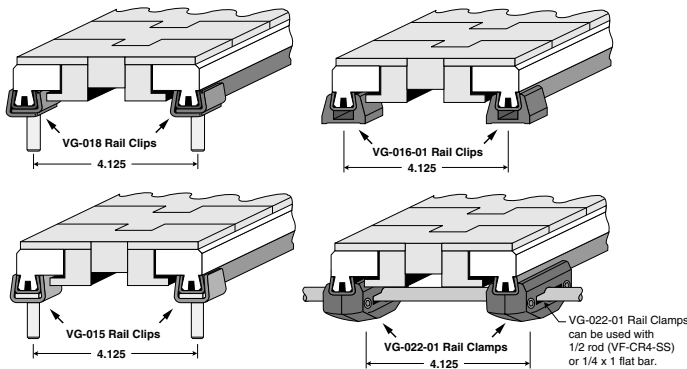

Tab Chain Guide mounting options

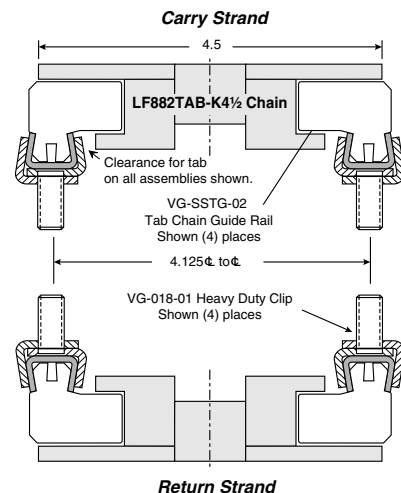

Tee Guide Rail with Premium UHMW Materials



Gray Nolu-S

Self lubricating Nolu-S UHMW insert and stainless steel sheath, 14 gauge.



Static Dissipating

Static dissipating UHMW insert and stainless steel sheath, 14 gauge.

		Length (ft.)
-	-	8
VG-SST-1.70-NS-10	VG-SST-1.70-SD-10	10
-	VG-SST-1.70-SD-12	12
VG-SST-1.70-NS-20	VG-SST-1.70-SD-20	20
-	VG-SSLT-1.0x.38-SD-8	8
VG-SSLT-1.0x.38-NS-10	VG-SSLT-1.0x.38-SD-10	10
VG-SSLT-1.0x.38-NS-12	VG-SSLT-1.0x.38-SD-12	12
VG-SSLT-1.0x.38-NS-20	VG-SSLT-1.0x.38-SD-20	20
-	VG-SSNG-SD-8	8
-	VG-SSNG-SD-10	10
VG-SSNG-NS-12	VG-SSNG-SD-12	12
VG-SSNG-NS-20	VG-SSNG-SD-20	20
VG-SSTG-02-NS-8	-	8
VG-SSTG-02-NS-10	VG-SSTG-02-SD-10	10
VG-SSTG-02-NS-12	VG-SSTG-02-SD-12	12
VG-SSTG-02-NS-20	-	20
VG-SSTG-03-NS-8	-	8
VG-SSTG-03-NS-10	-	10
VG-SSTG-03-NS-12	VG-SSTG-03-SD-12	12
VG-SSTG-03-NS-20	VG-SSTG-03-SD-20	20

*Tolerance on height is ± 0.025 .

AISI 316 stainless steel are available on a special order basis.

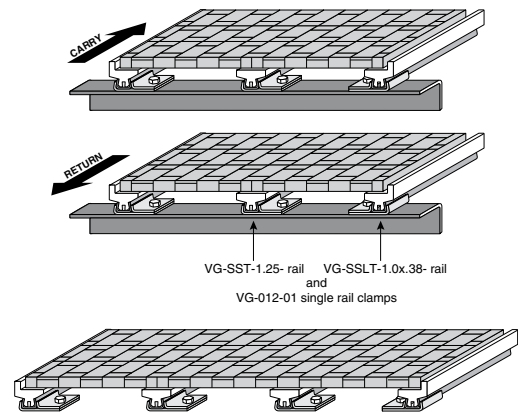
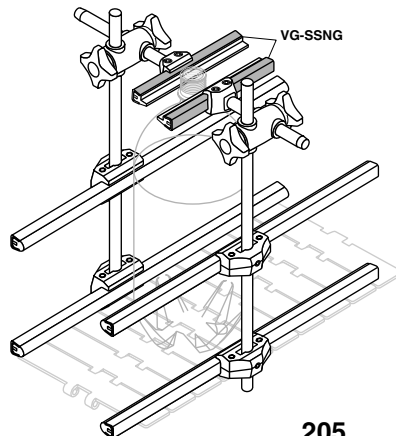
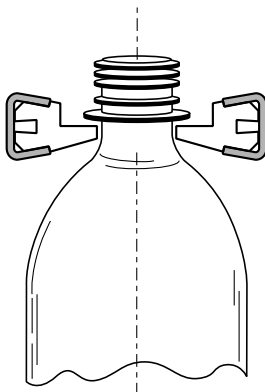

Valu Guide rail can accommodate various widths of metal or plastic belts.

Guide Rails and Hardware

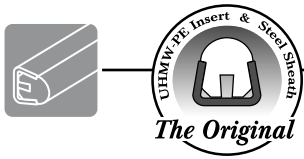

Chain Guide Rail

These chain guide rail shapes are also shown with roller chain guides on page 191.

Material: Sheath is stainless steel or galvanized steel, 14 gauge. Insert is UHMW.

#40

Chain Guide

Wear strip and guide for #40 ANSI single roller chains.

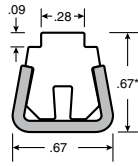
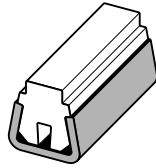

	Steel Sheath		Length (ft.)
	Stainless	Galvanized	
VG-SSCG-#40-8	VG-GSCG-#40-8	8	
VG-SSCG-#40-10	VG-GSCG-#40-10	10	
VG-SSCG-#40-12	VG-GSCG-#40-12	12	
VG-SSCG-#40-20	VG-GSCG-#40-20	20	

#50

Chain Guide

Wear strip and guide for #50 ANSI single roller chains.

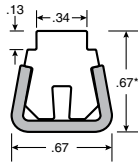
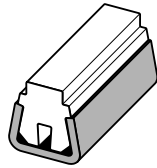

VG-SSCG-#50-8	VG-GSCG-#50-8	8
VG-SSCG-#50-10	VG-GSCG-#50-10	10
VG-SSCG-#50-12	-	12
VG-SSCG-#50-20	VG-GSCG-#50-20	20

#60

Chain Guide

Wear strip and guide for #60 ANSI single roller chains. Can also be used as side rail or wear strip when a wider surface contact is required.

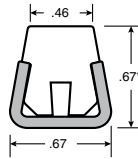
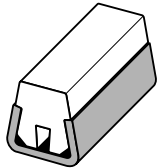

VG-SSF-8	VG-GSF-8	8
VG-SSF-10	VG-GSF-10	10
VG-SSF-12	VG-GSF-12	12
VG-SSF-20	VG-GSF-20	20

#80

Chain Guide

Wear strip and guide for #80 ANSI single roller chains.

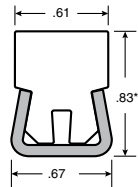
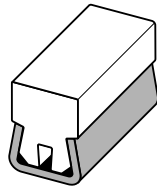

VG-SSCG-#80-8	VG-GSCG-#80-8	8
VG-SSCG-#80-10	VG-GSCG-#80-10	10
VG-SSCG-#80-12	VG-GSCG-#80-12	12
VG-SSCG-#80-20	VG-GSCG-#80-20	20

*Tolerance on height is $\pm 0.025"$.
Other lengths can be cut to order.

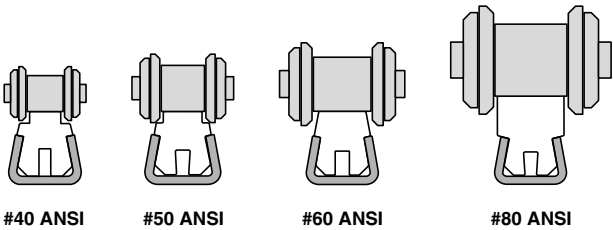

#40 ANSI

#50 ANSI

#60 ANSI

#80 ANSI

See pages
189-190
for more roller
chain guides!

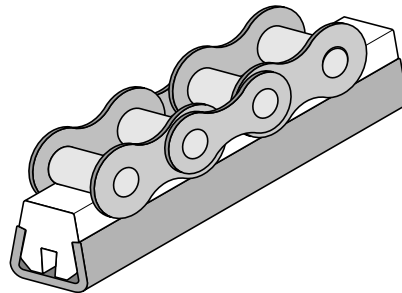



Extended Chain Guide Rail



Use where increased height is needed for extended side bar attachments. These chain guide rail shapes are also shown with roller chain guides on page 191.

#40

Extended Chain Guide

Wear strip and guide for #40 ANSI single roller chains.

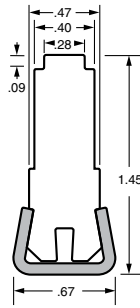
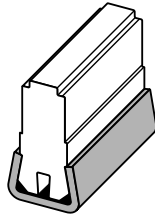

Material: Sheath is stainless steel or galvanized steel, 14 gauge. Insert is UHMW.

Steel Sheath		Length (ft.)
Stainless	Galvanized	
VG-SSECG-#40-8	VG-GSECG-#40-8	8
VG-SSECG-#40-10	VG-GSECG-#40-10	10
VG-SSECG-#40-12	VG-GSECG-#40-12	12
VG-SSECG-#40-20	VG-GSECG-#40-20	20

#50

Extended Chain Guide

Wear strip and guide for #50 ANSI single roller chains.

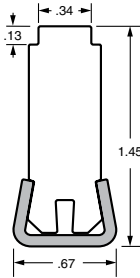
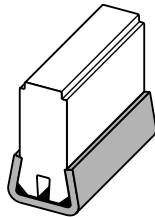

VG-SSECG-#50-8	VG-GSECG-#50-8	8
VG-SSECG-#50-10	VG-GSECG-#50-10	10
VG-SSECG-#50-12	-	12
VG-SSECG-#50-20	-	20

#60

Extended Chain Guide

Wear strip and guide for #60 ANSI single roller chains.

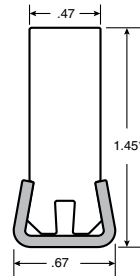
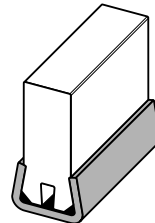

VG-SSECG-#60-8	VG-GSECG-#60-8	8
VG-SSECG-#60-10	VG-GSECG-#60-10	10
VG-SSECG-#60-12	VG-GSECG-#60-12	12
VG-SSECG-#60-20	VG-GSECG-#60-20	20

*Tolerance on height is ± 0.025 ".
Other lengths can be cut to order.

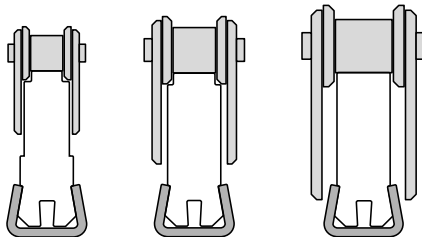
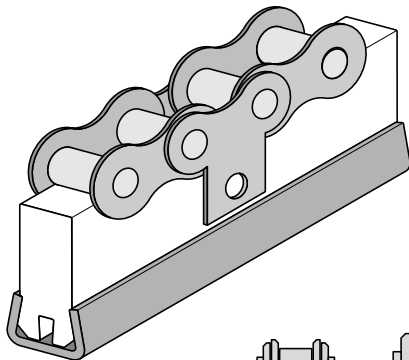

#40 ANSI

#50 ANSI

#60 ANSI

Important Note:

When Valu Guide Rail is used as a wear strip, the UHMW insert should be fastened to the metal sheath at the leading end of the rail. Using a sheet metal screw through the back of the sheath or a heavy wire pin from the side should be adequate. This will prevent the insert from sliding within the sheath in the event the chain accidentally catches on a leading edge. This also allows for thermal expansion and contraction of the UHMW insert.

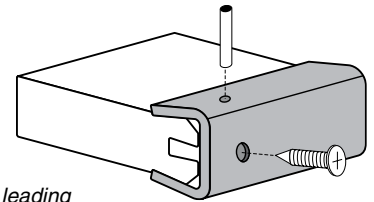

Guide Rails and Hardware



Solid Guide Rail

Since the original introduction of Valu Guide rail in 1981, we have been asked on occasion to provide profiles in which the UHMW insert completely fills the stainless steel sheath. For those special circumstances we carry a selection of guide rails with solid inserts.



Natural White UHMW

Material: UHMW Insert and stainless steel sheath, 14 gauge.

Guide Rails and Hardware

RS

Round Solid Rail

General purpose side rail for minimum container contact.

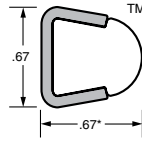
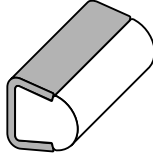

	Length (ft.)
VG-SSRS-8	8
VG-SSRS-10	10
VG-SSRS-12	12
VG-SSRS-20	20

FS

Flat Solid Rail

Side rail or wear strip. Can also be used as a chain guide for #60 roller chain.

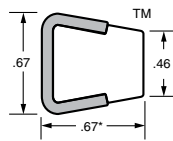
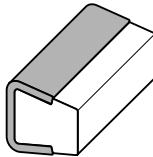

VG-SSFS-8	8
VG-SSFS-10	10
VG-SSFS-12	12
VG-SSFS-20	20

MS

Modified Solid Rail

Where minimum contact is desired in order to prevent damage during higher side loading conditions.

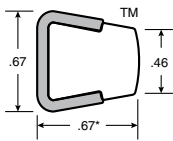
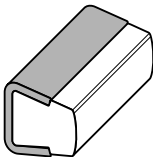

VG-SSMS-8	8
VG-SSMS-10	10
VG-SSMS-12	12
VG-SSMS-20	20

WFS

Wide Flat Solid Rail

Side rail or wear strip. Can be used in combination with the above rails when a greater contact area is required.

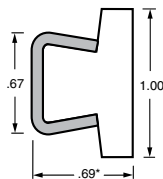
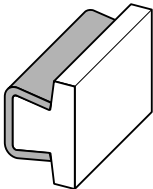

VG-SSWFS-8	8
VG-SSWFS-10	10
VG-SSWFS-12	12
VG-SSWFS-20	20

WFS-1.25

Wide Flat Solid Rail

Side rail or wear strip. Can be used in combination with the above rails when a greater contact area is required.

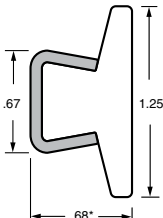
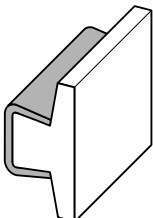

VG-SSWFS-1.25-8	8
VG-SSWFS-1.25-10	10
VG-SSWFS-1.25-12	12
VG-SSWFS-1.25-20	20

Solid Guide Rail with Premium UHMW Materials



Gray Nolu-S

Self lubricating Nolu-S UHMW insert and stainless steel sheath, 14 gauge.



Static Dissipating (black)

Static dissipating (black) UHMW insert and stainless steel sheath, 14 gauge.

VG-SSRS-NS-8
VG-SSRS-NS-10
VG-SSRS-NS-12
VG-SSRS-NS-20

-
VG-SSFS-NS-10
-
VG-SSFS-NS-20

-
VG-SSMS-NS-10
-
VG-SSMS-NS-20

-
VG-SSWFS-NS-10
-
VG-SSWFS-NS-20

-
VG-SSWFS-1.25-NS-10
VG-SSWFS-1.25-NS-12
VG-SSWFS-1.25-NS-20

	Length (ft.)
VG-SSRS-SD-8	8
VG-SSRS-SD-10	10
VG-SSRS-SD-12	12
VG-SSRS-SD-20	20

VG-SSFS-SD-8	8
VG-SSFS-SD-10	10
-	12
VG-SSFS-SD-20	20

VG-SSMS-SD-8	8
VG-SSMS-SD-10	10
-	12
-	20

VG-SSWFS-SD-8	8
VG-SSWFS-SD-10	10
VG-SSWFS-SD-12	12
VG-SSWFS-SD-20	20

VG-SSWFS-1.25-SD-8	8
VG-SSWFS-1.25-SD-10	10
VG-SSWFS-1.25-SD-12	12
VG-SSWFS-1.25-SD-20	20

*Tolerance on height is $\pm 0.025"$.
AISI 316 stainless steel are available on a special order basis.

Guide Rails and Hardware



Solid Tee Guide Rail

Since the original introduction of Valu Guide rail in 1981, we have been asked on occasion to provide profiles in which the UHMW insert completely fills the stainless steel sheath. For those special circumstances we carry a selection of guide rails with solid inserts. Valu Guide Solid Tee Guide Rail can be used as a side rail when a larger container contact area is required or as a wear strip for wide metal or plastic belting and slat top chain.



Natural White UHMW

Material: UHMW Insert and stainless steel sheath, 14 gauge.

Guide Rails and Hardware

TS-1.00

Tee Solid Rail

Can be used as a side rail or as a wear strip.

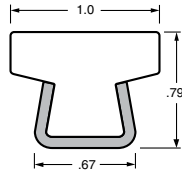
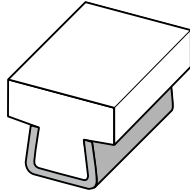

Length (ft.)

VG-SSTS-1.00-8	8
VG-SSTS-1.00-10	10
VG-SSTS-1.00-12	12
VG-SSTS-1.00-20	20

TS-1.25

Tee Solid Rail

Can be used as a side rail or as a wear strip.

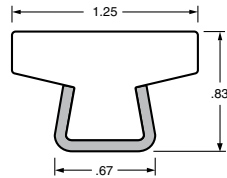
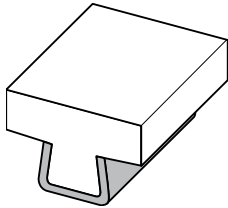

VG-SSTS-1.25-8	8
VG-SSTS-1.25-10	10
VG-SSTS-1.25-12	12
VG-SSTS-1.25-20	20

LTS

EII Tee Solid Rail

Wear strip and side guide for modular wide belts. Provides positive edge tracking and a low friction, abrasion resistant support.

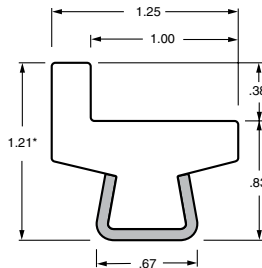
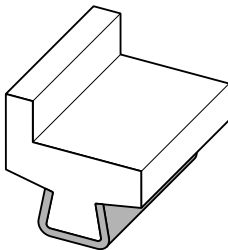

VG-SSLTS-1.0x.38-8	8
VG-SSLTS-1.0x.38-10	10
VG-SSLTS-1.0x.38-12	12
VG-SSLTS-1.0x.38-20	20

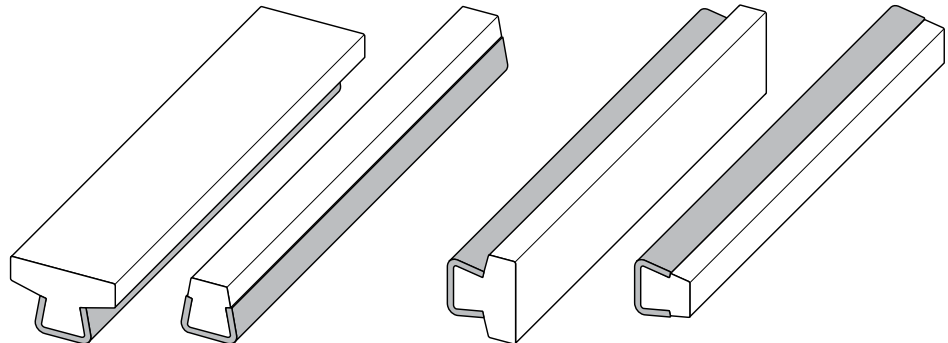

Use as wear strips for plastic or steel belting.

Use as side guides for glass and metal containers.



Gray Nolu-S

Self lubricating Nolu-S UHMW insert and stainless steel sheath, 14 gauge.



Static Dissipating (black)

Static dissipating (black) UHMW insert and stainless steel sheath, 14 gauge.

Length (ft.)

VG-SSTS-1.00-NS-8
VG-SSTS-1.00-NS-10
-
VG-SSTS-1.00-NS-20

-	8
VG-SSTS-1.00-SD-10	10
VG-SSTS-1.00-SD-12	12
VG-SSTS-1.00-SD-20	20

VG-SSTS-1.25-NS-8
VG-SSTS-1.25-NS-10
VG-SSTS-1.25-NS-12
VG-SSTS-1.25-NS-20

-	8
VG-SSTS-1.25-SD-10	10
VG-SSTS-1.25-SD-12	12
VG-SSTS-1.25-SD-20	20

-
VG-SSLTS-1.0x.38-NS-10
VG-SSLTS-1.0x.38-NS-12
VG-SSLTS-1.0x.38-NS-20

VG-SSLTS-1.0x.38-SD-8	8
VG-SSLTS-1.0x.38-SD-10	10
VG-SSLTS-1.0x.38-SD-12	12
VG-SSLTS-1.0x.38-SD-20	20

*Tolerance on height is $\pm 0.025"$.
AISI 316 stainless steel are available on a special order basis.

Guide Rails and Hardware



Static Dissipative Rail reduces static buildup and discharge.

Protect personnel, sensitive products or electrical components with Valu Guide's proprietary static dissipating guide rail material.

Plastic packaging and PET bottles can generate high levels of static buildup as they travel along a conveyor. Static Dissipative Rail is more conductive than natural UHMW and provides static buildup with a pathway to the surrounding conveyor frame where it can dissipate. Conveyor frames may need to be grounded. Valu Guide's special formulation retains the low friction and wear characteristics of UHMW while effectively reducing problems caused by static such as shocks or containers sticking together.

Material: Sheath is stainless steel, 14 gauge. Insert is static dissipative UHMW.

Guide Rails and Hardware

R-SD

Round Static Dissipative
Reduces static buildup and discharge. Side rail for minimum container contact.

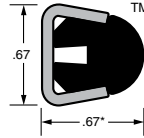

	Length (ft.)
VG-SSR-SD-8	8
VG-SSR-SD-10	10
VG-SSR-SD-12	12
VG-SSR-SD-20	20

*Tolerance on height is ±0.025".

F-SD

Flat Static Dissipative
Reduces static buildup and discharge. Side rail or wear strip when a wider surface contact is required. Can also be used as a chain guide for #60 roller chain.

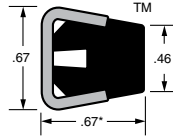
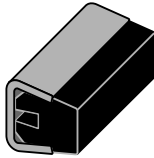

	8
VG-SSF-SD-10	10
VG-SSF-SD-12	12
VG-SSF-SD-20	20

+Tolerance on height is ±0.025".

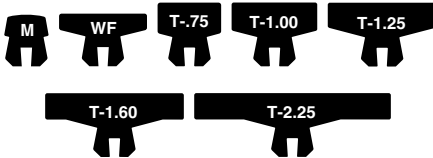

The Round and Flat rails shown above are representative of the full line of static dissipating guide rails available from Valu Guide.

All other profile shapes featured in this catalog can be produced as static dissipative.

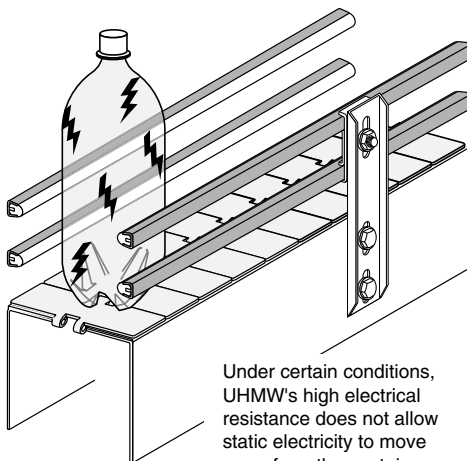
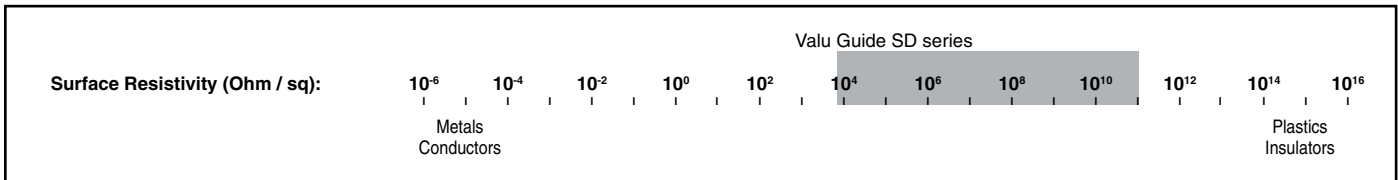

Under certain conditions, UHMW's high electrical resistance does not allow static electricity to move away from the container, resulting in static build-up.

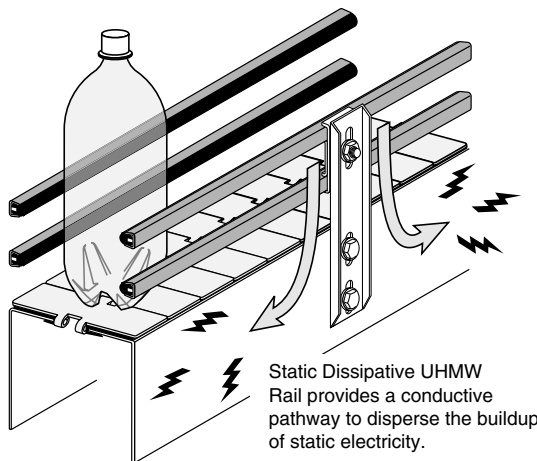

Static Dissipative UHMW Rail provides a conductive pathway to disperse the buildup of static electricity.



Hi-Temp Rail for use where increased operating temperatures exist.

Performs in Continuous Temperatures up to 500°F!

- For use in:**
- ✓ Steam Chambers
 - ✓ Ovens
 - ✓ Cookers
 - ✓ Hot Fill Area
- ✓ Shrink Tunnels
 - ✓ Furnace Discharge
 - ✓ Retorts
 - ✓ Fryers
- ✓ Pasteurizers
 - ✓ Steam Boxes

F-HT

Hi-Temp Flat

Where increased temperatures exist, use as side rail or wear strip when a wide surface contact is required. Can also be used as a chain guide for #60 roller chain.

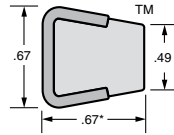
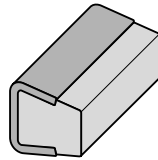

Material: Sheath is stainless steel or galvanized steel, 14 gauge. Insert is PTFE hi-temp material.

	Steel Sheath		Length (ft.)
	Stainless	Galvanized	
VG-SSF-HT-4		VG-GSF-HT-4	4
VG-SSF-HT-5		VG-GSF-HT-5	5
VG-SSF-HT-8		VG-GSF-HT-8	8
VG-SSF-HT-10		VG-GSF-HT-10	10

*Tolerance on height is ±0.025".

T-HT

Hi-Temp Tee

Where increased temperatures exist, use as wear strip for wide metal or plastic belting and slat top chain. Also used as side rail when a larger container contact area is required.

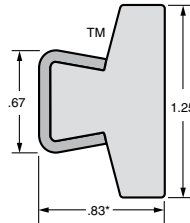
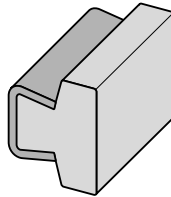

VG-SST-HT-1.25-4	-	4
VG-SST-HT-1.25-5	VG-GST-HT-1.25-5	5
VG-SST-HT-1.25-8	VG-GST-HT-1.25-8	8
VG-SST-HT-1.25-10	VG-GST-HT-1.25-10	10

*Tolerance on height is ±0.025".

Narrower tee dimensions are available. Please contact customer service for special requirements.

The minimum bending radius for Hi-Temp Tee turn applications is 6 inches.

Specifications	Hi-Temp Material	Steel Sheath
Tensile Strength (ASTM D-638 (psi))	1500-3000	70,000
Deformation Under Load (ASTM D-621 (%))	3.8	---
Coefficient of Thermal Expansion (ASTM D-696 in/in/°F x 10 ⁻⁵)	5.5 x 10 ⁻⁵	.96
Coefficient of Friction	.04	---
Continuous Service Temperature	-400°F (min.), 500°F (max.)	---

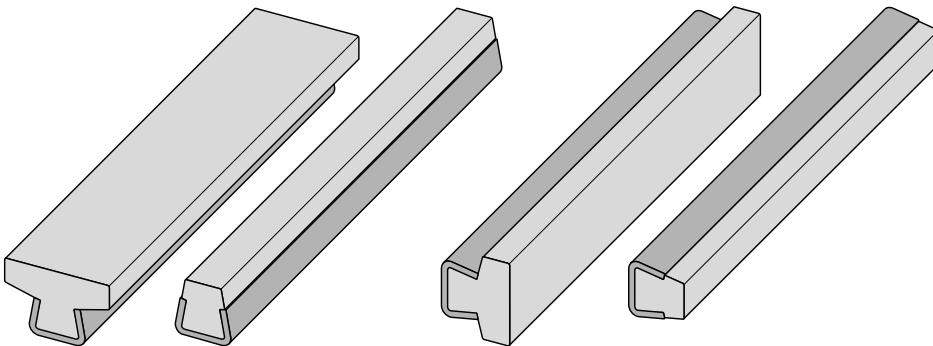

Use as wear strips for plastic or steel belting.

Use as side guides for glass and metal containers.

Important Note:

When Valu Guide Rail is used as a wear strip, the UHMW insert should be fastened to the metal sheath at the leading end of the rail. Using a sheet metal screw through the back of the sheath or a heavy wire pin from the side should be adequate. This will prevent the insert from sliding within the sheath in the event the chain accidentally catches on a leading edge. This also allows for thermal expansion and contraction of the UHMW insert.

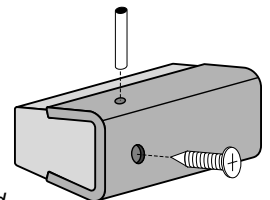

Guide Rails and Hardware



PolyGlide™

Guide rail for use with plastics such as PET and polypropylene.

PolyGlide™ rail is designed to be an economical solution to guiding plastic containers, cartons, and conveyor belting. PolyGlide™ is constructed using stainless steel as the guide contact surface and can be used with all standard Valu Guide rail clips and clamps.



PolyGlide reduces static buildup.

Plastic packaging and PET bottles can generate high levels of static buildup as they travel along a conveyor. PolyGlide provides static buildup with a pathway to the surrounding conveyor frame where it can dissipate. Conveyor frames may need to be grounded.



PolyGlide can be used in higher operating temperatures.

PolyGlide can withstand harsh environments such as:

- Steam Chambers*
- Shrink Tunnels*
- Ovens*
- Furnace Discharge*
- Pasteurizers*
- Cookers*
- Steam Boxes*
- Hot Fill Area*
- Fryers*

Guide Rails and Hardware

SPM



PolyGlide Rail

Economical guide for plastic containers and conveyor belting. Can be used with all standard Valu Guide rail clips and clamps. VG-PMI-inserts required for use with rail clamps.

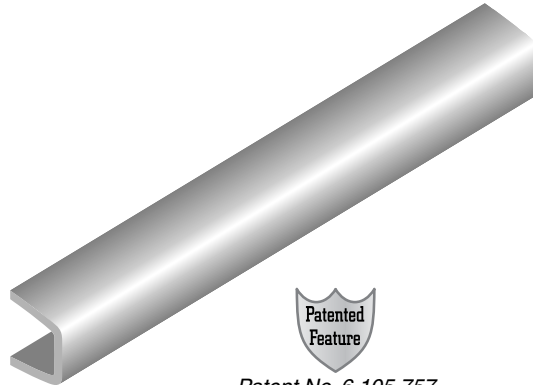

Patent No. 6,105,757

Material: stainless steel, 14 gauge.

Part Number	Length (ft.)
VG-SPM-4	4
VG-SPM-5	5
VG-SPM-6	6
VG-SPM-8	8
VG-SPM-10	10
VG-SPM-12	12
VG-SPM-20	20

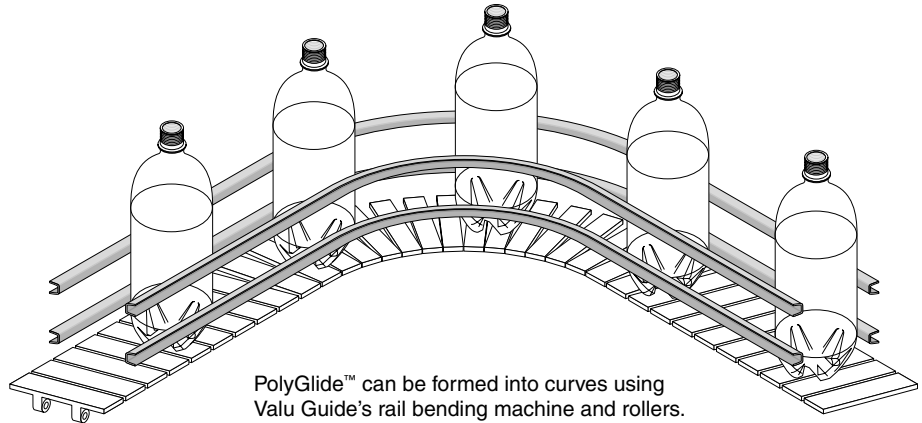

PolyGlide™ can be formed into curves using Valu Guide's rail bending machine and rollers.

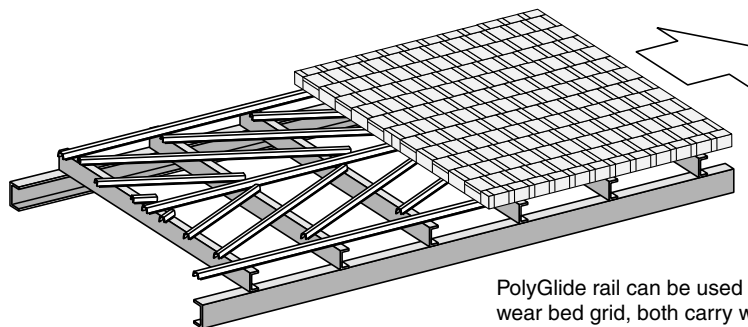
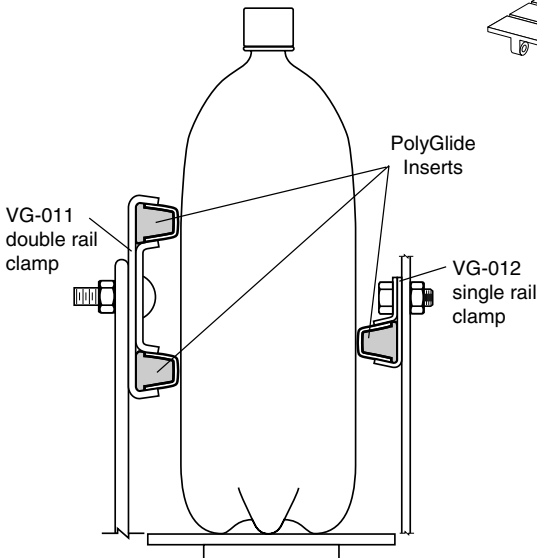

PolyGlide rail can be used as a wear bed grid, both carry way and return way, for plastic belting.



PMI-25

Plastic Insert

Used with PolyGlide rail in conjunction with Valu Guide clips and clamps. Temperature range: -40°F to 140°F. For higher or lower temperatures, use stainless steel insert part number VG-PMI-30.

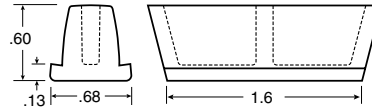
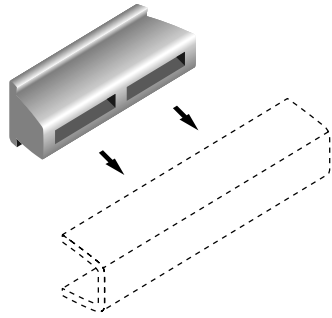

Material: Santoprene plastic.

Part Number

VG-PMI-25

PMI-30

Stainless Steel Insert

Used with PolyGlide rail in conjunction with Valu Guide clips and clamps in harsh environments such as extreme temperatures or corrosive areas.

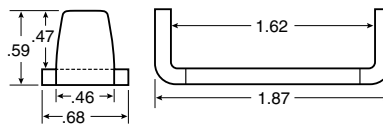
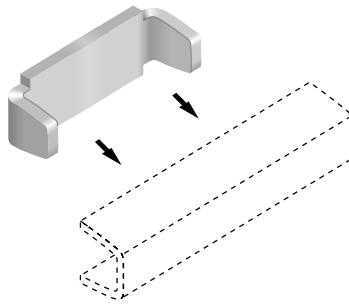

Material: stainless steel.

Part Number

VG-PMI-30

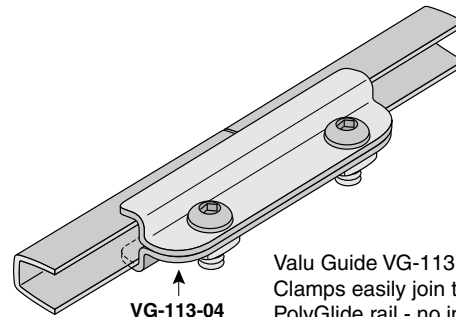
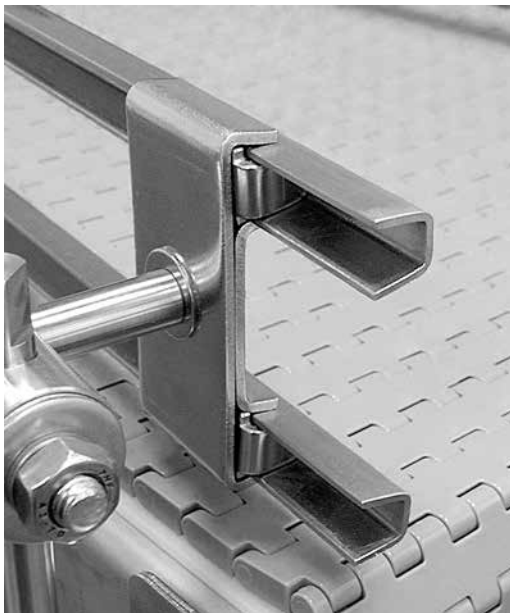

Valu Guide VG-113 Series Splice Clamps easily join two pieces of PolyGlide rail - no insert is required.



Patent No. 6,053,654

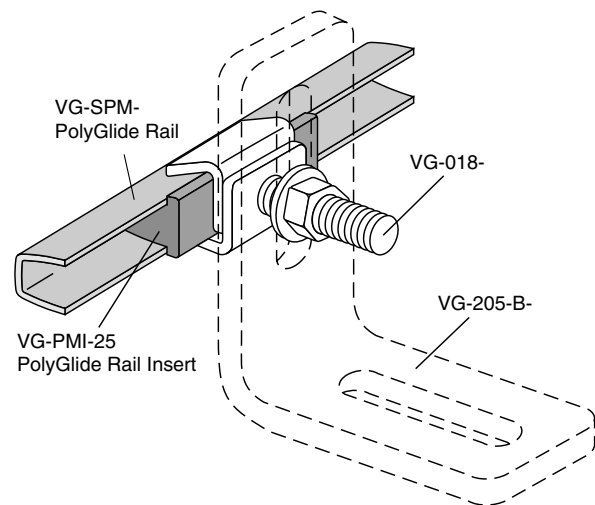
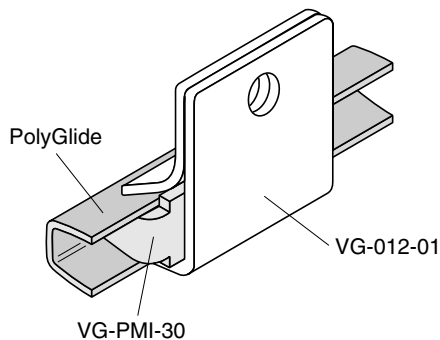

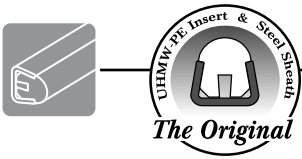

Lane Dividers

LD

Lane Divider

Lane dividers are used to separate containers on a conveyor into multiple lanes.

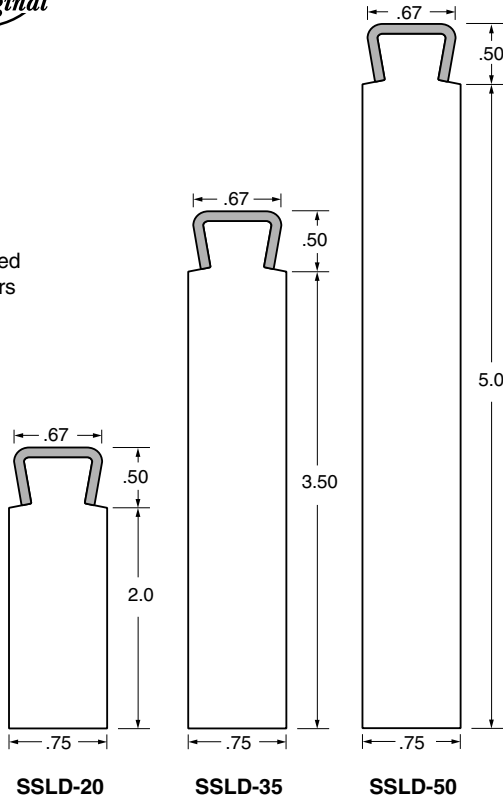

Material: Sheath is stainless steel, 14 gauge. Insert is UHMW.

Part Number	Length* (ft.)
VG-SSLD-20-5	5
VG-SSLD-20-10	10
VG-SSLD-35-5	5
VG-SSLD-35-10	10
VG-SSLD-50-5	5
VG-SSLD-50-10	10

*Other lengths can be cut to order.

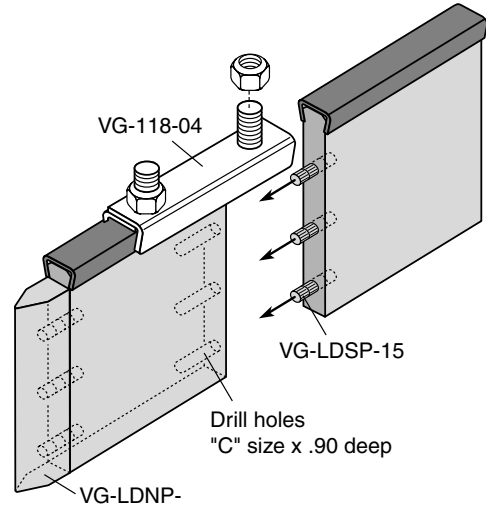

LDNP

Nose Plow

For LD dividers. Pins included.

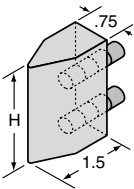

Material: UHMW, SS pins.

Part Number	H (in.)	Pins
VG-LDNP-20	2	2
VG-LDNP-35	3½	3
VG-LDNP-50	5	3

LDSP

Splicing Pins

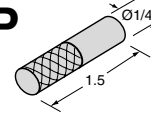

Material: Stainless steel.

Part Number	Length (in.)
VG-LDSP-15	1½

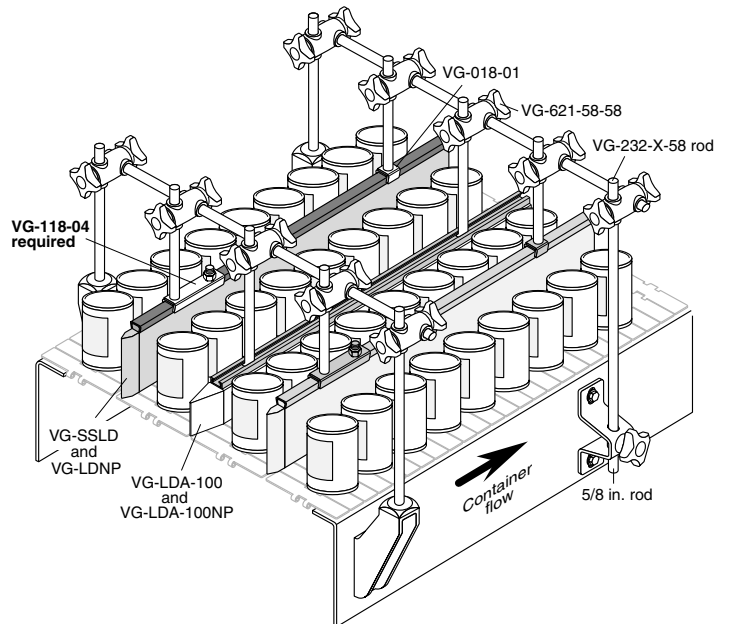
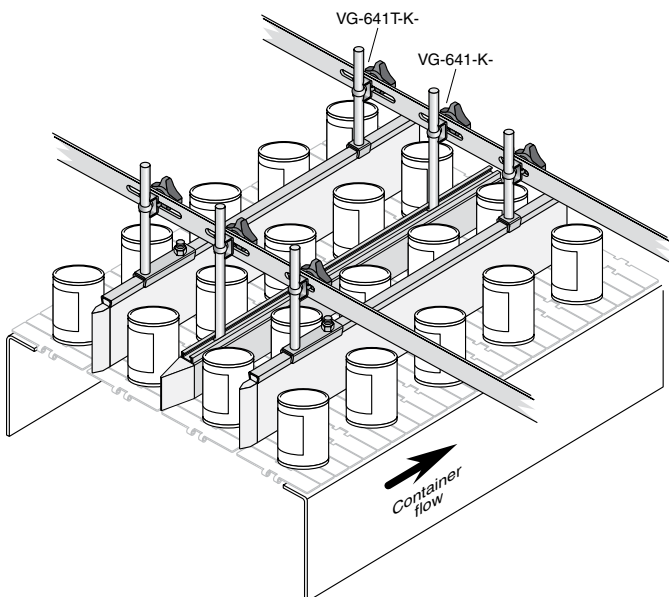



LDA-100

Lane Divider
Bendable to 40" radius.

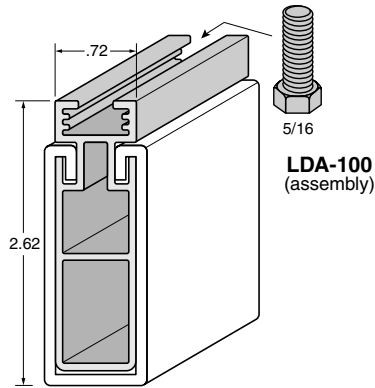

Material: Aluminum.

Part Number	Length (ft.)
VG-LDA-100-10	10
VG-LDA-100-20	20

LDP

UHMW Cover
Replacement for VG-LDA-100 assembly.

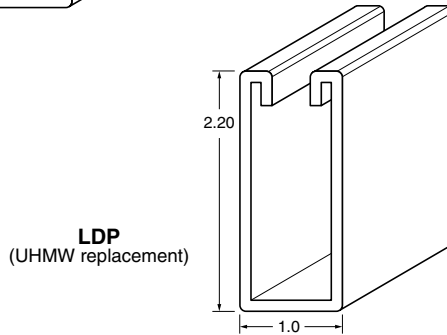

Material: UHMW.

Part Number	Length (ft.)
VG-LDP-100-10	10
VG-LDP-100-20	20

LDA-100NP

Nose Plow
For LDA dividers.

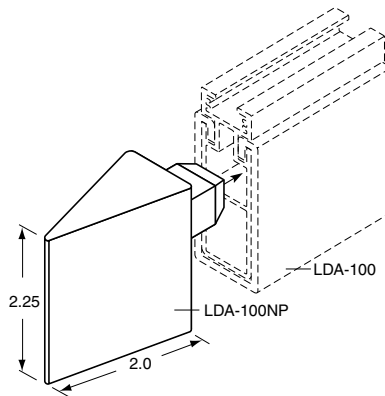

Material: UHMW.

Part Number
VG-LDA-100NP

Guide Rails and Hardware

UHMW Wear Bed Grid

Valu Guide as a wear strip?

YES! Many companies are using Valu Guide rail as wear strips under their conveyor belts (read important note below for installation requirements). They have found that it is an excellent compliment to virtually all plastic and metal chains and belting. For additional conveyor chain guiding options, see section starting on page 101.



The **advantages** of using Valu Guide are:

- Reduced drag
- Longer service life
- Added structural support
- Simple fabrication, easy installation
- Elimination of thermal expansion problems
- Even distribution of wear and load over width of belt
- Improved sanitation - eliminates buildup between wear strip and support
- Styles to fit most any application - Flat, Modified, L-Tee, Tee (.75, 1.00, 1.25, 1.60, 2.25)

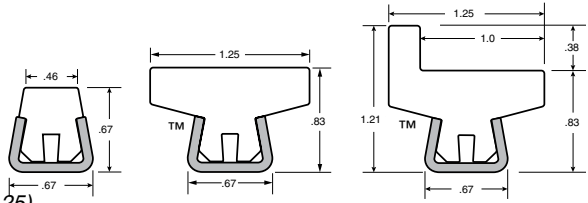
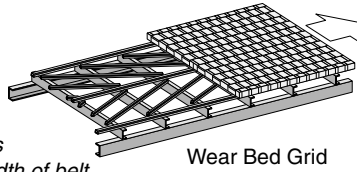

Flat, Tee, and L-Tee Profiles

1. Type of belting _____
2. Weight of belting (pounds per square foot) _____
3. Top load (product weight per square foot) _____
4. Conveyor width _____
5. Belt speed (feet per minute) _____
6. Operating Temperature _____
7. What type of return is planned? Rollers (see pg. 427) Wear Bed
8. Is this wear bed a: New design
 Replacement (Type: _____)

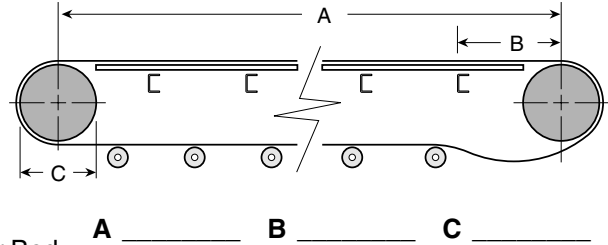

**FAX THIS INFORMATION
FOR YOUR CUSTOM DESIGN
FAX (866) 447-6587**

Typical carry and return way wear strip configuration for wide plastic or metal belting utilizing Valu Guide Rail.

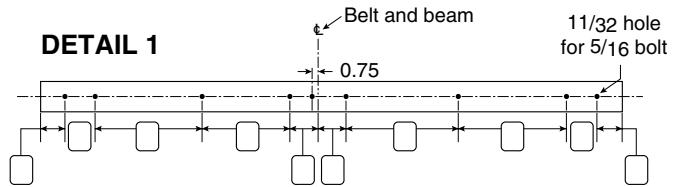
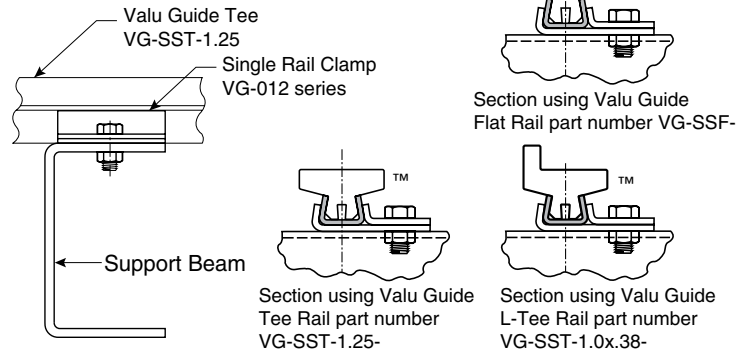
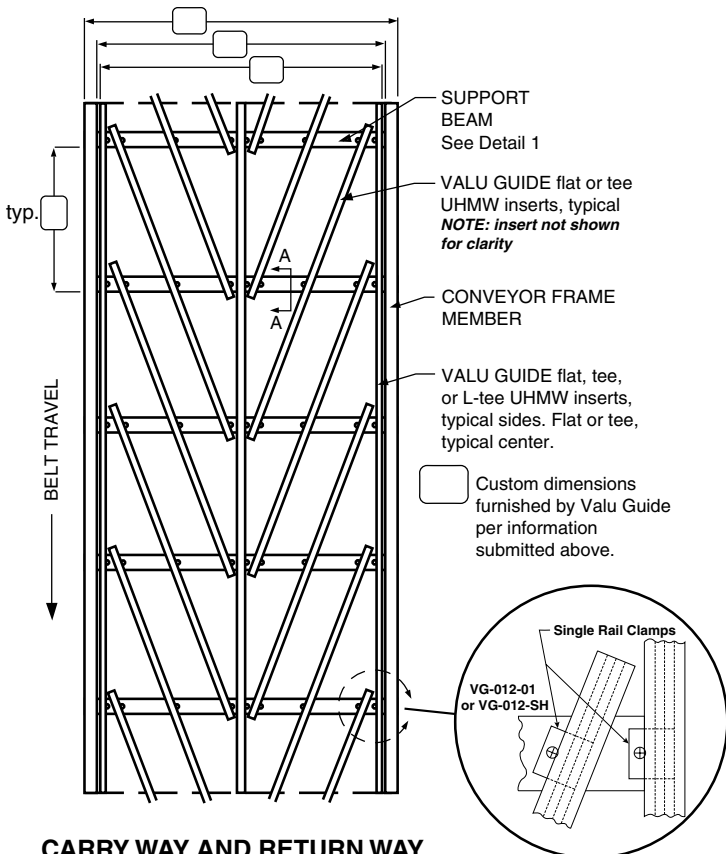

CARRY WAY AND RETURN WAY WEAR BED GRID CUSTOM DESIGN SUPPORT

You can receive a custom preliminary quote for your specific carry way and return way application(s) by submitting the above information.

Important Note:

When Valu Guide Rail is used as a wear strip, the UHMW insert should be fastened to the metal sheath at the leading end of the rail. Using a sheet metal screw through the back of the sheath or a heavy wire pin from the side should be adequate. This will prevent the insert from sliding within the sheath in the event the chain accidentally catches on a leading edge. This also allows for thermal expansion and contraction of the UHMW insert.

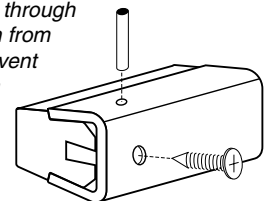



730

Corner Block Inserts

For use when the smallest corner radius is required. Most desirable when transferring at right angles on and off accumulating tables.

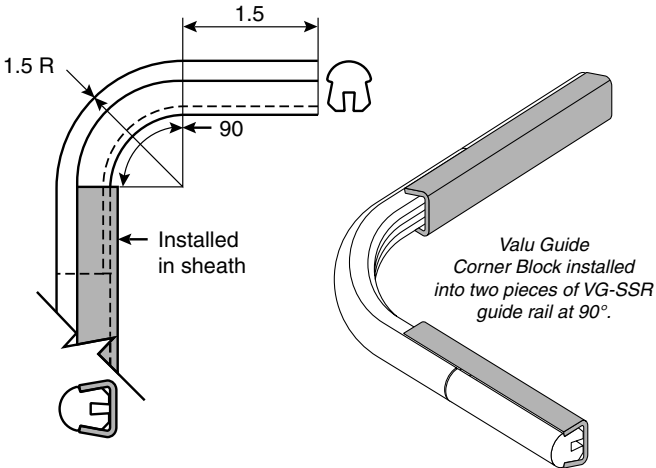

Material: UHMW.

VG-730-01	VG-730-05	VG-730-07	VG-730-09

Guide Rails and Hardware

761

Twist Insert

For use in container fittings as an alternative to metal rods. Twist Insert is flexible, non-marking, and noise reducing. Typically used in both straight and radiused applications, and easily adjoins to Valu Guide rail.

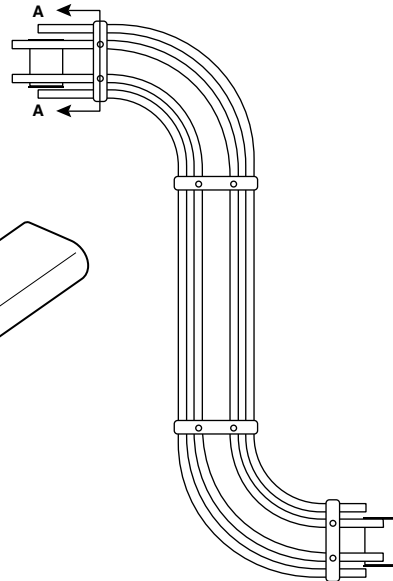
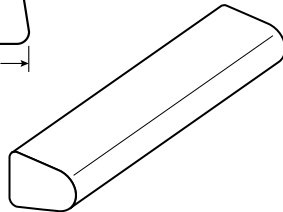
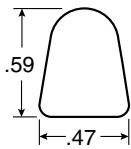

Material: UHMW.

Part Number	Length (ft.)
VG-761-10	10

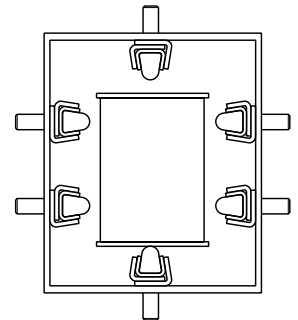

Section A - A

013

Insert Sleeve

For use with Twist Inserts. Allows attachment of Valu Guide rail clips, clamps, and connectors such as VG-012, VG-014H, VG-015, VG-016 or VG-018.

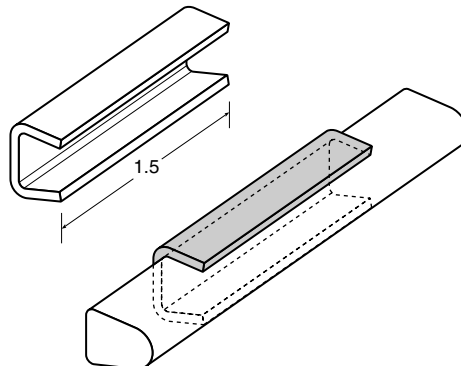
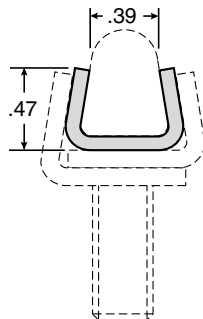

Material: Stainless steel, 14 gauge.

Part Number	Length (in.)
VG-013-02	1½

Hand Guide Rail Benders

Bend rails into curves with professional results!

Hand Guide Rail Bender

System Plast has developed, and makes available for purchase or rental, a light weight rail bending machine. The machine is portable and can easily be carried by one person to either the job site or the work area. Hand bending techniques cannot match the speed, accuracy and quality of curves made with the bending machine.

Each bender is supplied with rollers (roller set part number **VG-RS-01**) to bend Valu Guide round, flat, modified and Tee-rails. Additional rollers for bending additional rail styles are also available. In the event you're not satisfied with your bend, the bender can be used to straighten the pieces for re-bending.

Shipping weight is 56 lbs. Detailed instructions are furnished with each machine.



Available for Rental or Purchase

Guide Rails and Hardware

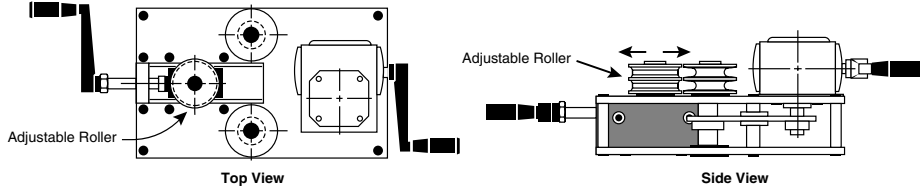

VG-690

Hand Guide Rail Bender

Supplied with part number **VG-RS-01** which includes two VG-691A rollers, two VG-691B rollers, and two VG-692 rollers.

Part Number

VG-690 Includes VG-RS-01 roller set

Outside Curve

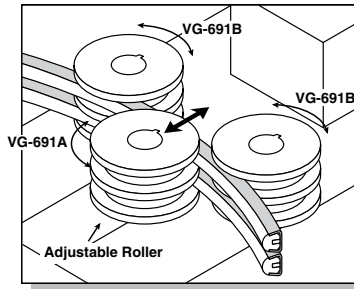

Inside Curve

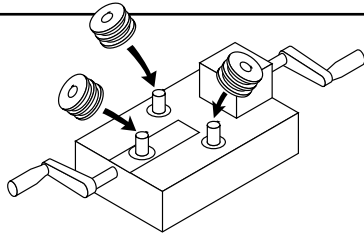
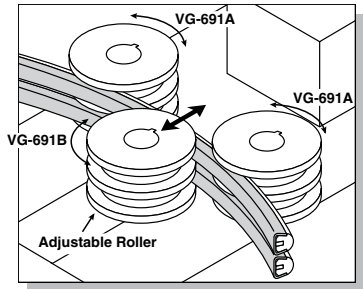

Hand Guide Rail Bender Rollers

System Plast rails can be quickly and easily formed to practically any radius without distortion of the rail or damage to the insert. This is achieved by the use of the contoured rollers on the bending machine. The rollers manipulate the rail during bending while protecting the insert from damage. Large and small radius turns, including offsets, can be produced.

RS-01

Bends two rails simultaneously!

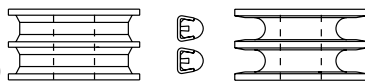

Roller Set Part Number

VG-RS-01

Included in set: **VG-691A** (2 ea.)

VG-691B (2 ea.)

VG-692 (2 ea.)

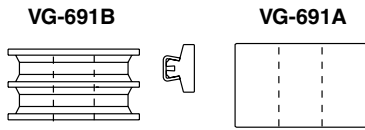

Valu Guide round, flat, modified and neck guide profiles Minimum radius: 3 in.	Outside Curves		Inside Curves	
	1 roller	2 rollers	1 roller	2 rollers
	VG-691A	VG-691B	VG-691B	VG-691A
Valu Guide tee profiles Minimum radius: 4 in.	VG-692	VG-691B	VG-691B	VG-692

RS-02

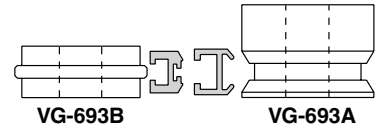

Roller Set Part Number

VG-RS-02

Included in set: **VG-693A** (2 ea.)

VG-693B (2 ea.)

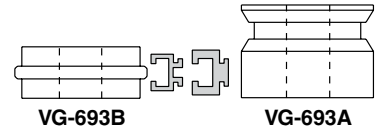

VG-A350, VG-A500 Minimum radius: Inside curve: 6 in. Outside curve: 5 in. Rail can be bent with cover in place	Outside Curves		Inside Curves	
	1 roller	2 rollers	1 roller	2 rollers
	VG-693A	VG-693B	VG-693B	VG-693A
VG-A600, VG-A225 Minimum radius: Inside curve: 6 in. Outside curve: 5 in. Rail can be bent with cover in place	VG-693A	VG-693B	VG-693B	VG-693A

RS-03

Roller Set Part Number

VG-RS-03

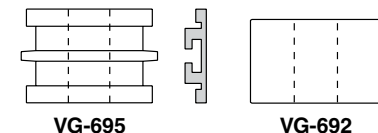

VG-A2520 profile Minimum radius: Inside curve: 8 in. Outside curve: 7 in. Add UHMW cover (VG-P2520BC) after bending	Outside Curves		Inside Curves	
	1 roller	2 rollers	1 roller	2 rollers
	VG-692	VG-695	VG-695	VG-692

RS-04

Bends two rails simultaneously!

Roller Set Part Number

VG-RS-04

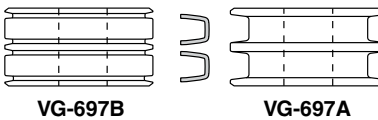

Valu Guide PolyGlide rail Minimum radius: 4 inches	Outside Curves		Inside Curves	
	1 roller	2 rollers	1 roller	2 rollers
	VG-697A	VG-697B	VG-697B	VG-697A



RS-05

Roller Set Part Number
VG-RS-05

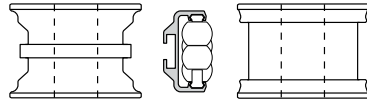

VG-698A

VG-698B

VG-686A-1.25 SpeedRail Minimum radius: 12 inches	Outside Curves		Inside Curves	
	1 roller	2 rollers	1 roller	2 rollers
	VG-698B	VG-698A	VG-698A	VG-698B

RS-06

Roller Set Part Number
VG-RS-06

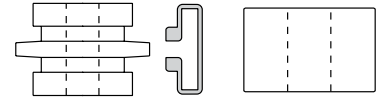

VG-696

VG-692

VG-A5020 profile Minimum radius: Inside curve: 8 in. Outside curve: 7 in. Add UHMW cover (VG-P5020BC) after bending	Outside Curves		Inside Curves	
	1 roller	2 rollers	1 roller	2 rollers
	VG-692	VG-696	VG-696	VG-692

RS-07

Roller Set Part Number
VG-RS-07

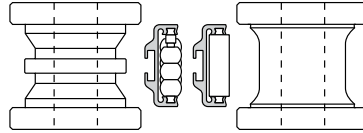

VG-698D

VG-698C

VG-687H-1.4 SpeedRail SB VG-688H-1.4 SpeedRoll Minimum radius: 12 inches	Outside Curves		Inside Curves	
	1 roller	2 rollers	1 roller	2 rollers
	VG-698D	VG-698C	VG-698C	VG-698D

RS-08

Roller Set Part Number
VG-RS-08

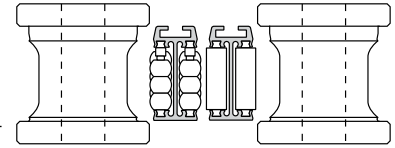

VG-698E

VG-698E

VG-687-1.4 SpeedRail SB VG-688-1.4 SpeedRoll Minimum radius: 12 inches	Outside Curves	Inside Curves
	VG-698E	

RS-09

Bends two rails simultaneously!

Roller Set Part Number
VG-RS-09

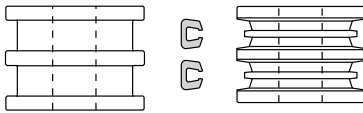

VG-694B

VG-694A

VG-ABG-profile Minimum radius: 30 inches	Outside Curves		Inside Curves	
	1 roller	2 rollers	1 roller	2 rollers
	VG-694A	VG-694B	VG-694B	VG-694A

RS-11

Roller Set Part Number
VG-RS-11

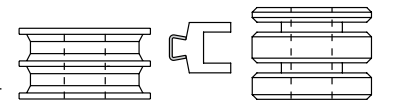

VG-691B

VG-699-1.3

VG-SSUT-1.30 Conveyor belt side guide Minimum radius: 18 inches	Outside Curves		Inside Curves	
	1 roller	2 rollers	1 roller	2 rollers
	VG-699-1.3	VG-691B	VG-691B	VG-699-1.3

RS-12

Roller Set Part Number
VG-RS-12

VG-691B set included with bender.

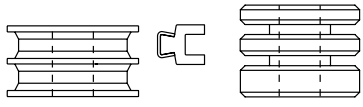

VG-691B

VG-699-1.0

VG-SSUT-1.00 Conveyor belt side guide Minimum radius: 18 inches	Outside Curves		Inside Curves	
	1 roller	2 rollers	1 roller	2 rollers
	VG-699-1.0	VG-691B	VG-691B	VG-699-1.0

RS-14

Bends two rails simultaneously!

Roller Set Part Number
VG-RS-14

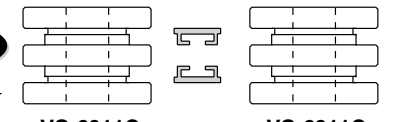

VG-6911C

VG-6911C

VG-BWS- Conveyor belt support Minimum radius: 24 inches	Outside Curves	Inside Curves
	VG-6911C	

RS-15

Roller Set Part Number
VG-RS-15

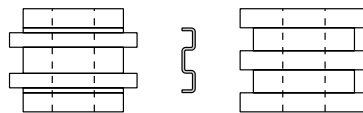

VG-6912A

VG-6912B

190265 M-Profile Minimum radius: 18 inches	Outside Curves		Inside Curves	
	1 roller	2 rollers	1 roller	2 rollers
	VG-6912B	VG-6912A	VG-6912A	VG-6912B

Guide Rails and Hardware



Replacement Rollers for Motorized Guide Rail Benders

Motorized Bender

Bends steel or aluminum rails into curves, individually or in pairs. Millimeter and decimal reading for pressing roller adjustment. Rollers sold separately.

Motor: V.440 volt / 60Hz

Note: Motorized Bender is no longer sold.

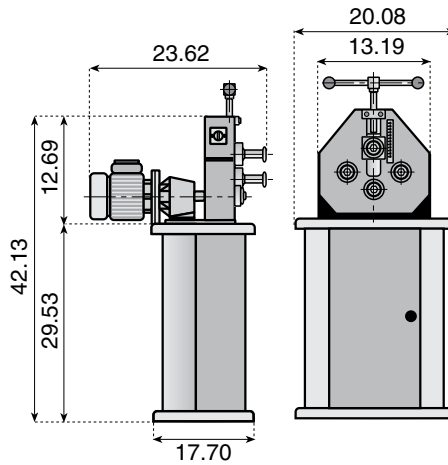

Inside Curve

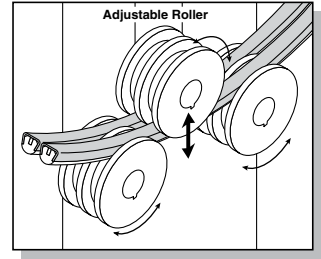

Outside Curve

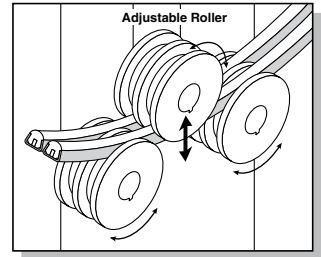

Replacement Rollers for Motorized Bender

19500

Bends two rails simultaneously!

Roller Set Part Number

19500

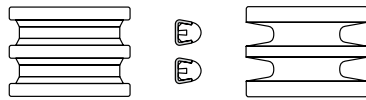

19500

19500

Round, flat, modified and neck guide profiles Minimum radius: 6 inches	Outside Curves 2 rollers	Inside Curves 2 rollers
	19500	19500

19506

Roller Set Part Number

19506

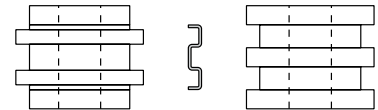

19506

19506

190265 M-Profile Minimum radius: 18 inches	Outside Curves 2 rollers	Inside Curves 2 rollers
	19506	19506

19507

Roller Set Part Number

19507

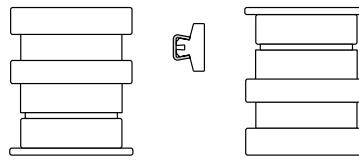

19507

19507

Tee profile Minimum radius: 6 inches	Outside Curves 2 rollers	Inside Curves 2 rollers
	19507	19507



Single Rail Clamps



Rail Clamps support guide rail for industrial applications such as conveyor guide rail or wear beds. Rail Clamps offer heavy duty strength and corrosion resistance. For added corrosion protection, 316 stainless steel is also available. Round hole versions accept hex bolts and square hole versions accept hex or carriage bolts (due to variations in carriage bolt head diameters, it may be necessary to put a flat on the bolt head to avoid interference with the clamp).

Guide Rails and Hardware

Single Rail Clamp
Round hole, 1.5 inches wide.

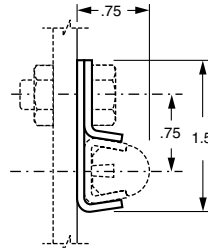
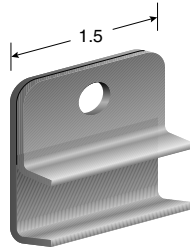

Material: Stainless steel, 14 gauge. Part numbers ending in -316 are 316 stainless steel.

Part Number	Fastener
VG-012-01	5/16 or M8
VG-012-01-316	5/16 or M8



Single Rail Clamp
Square hole, 1.5 inches wide.

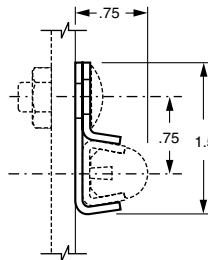
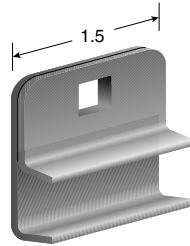

Part Number	Fastener
VG-012-SH	5/16 or M8
VG-012-SH-316	5/16 or M8



Single Rail Clamp
Round hole, 3 inches wide for splicing.

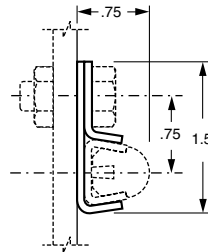
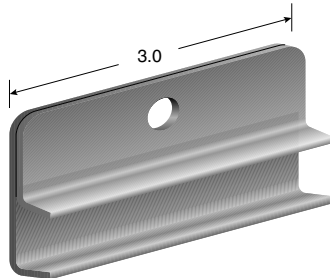

Part Number	Fastener
VG-012-03	5/16 or M8
VG-012-03-316	5/16 or M8



Single Rail Clamp
Square hole, 3 inches wide for splicing.

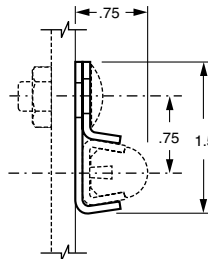
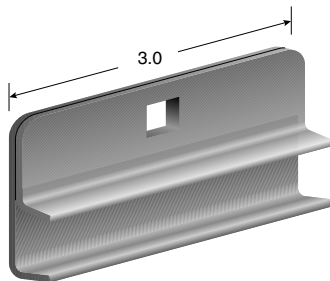

Part Number	Fastener
VG-012-03-SH	5/16 or M8
VG-012-03-SH-316	5/16 or M8

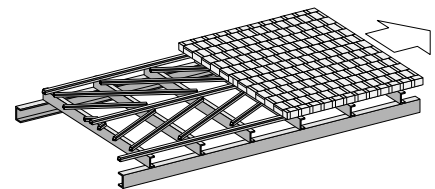
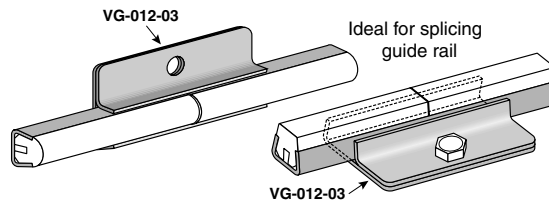
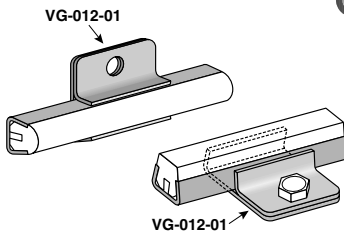

Single Rail Clamps can be used to hold guide rail for a wear bed grid.



Double Rail Clamps

Double Rail Clamp

Round hole, choice of rail center dimensions.

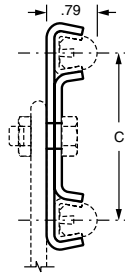
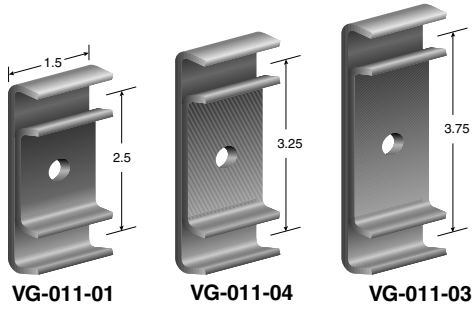

Material: Stainless steel, 11 gauge.

Part Number	(C) Rail Centers (in.)	Fastener
VG-011-01	2.5	3/8 or M10
VG-011-04	3.25	3/8 or M10
VG-011-03	3.75	3/8 or M10



Guide Rails and Hardware

Double Rail Clamp

Square hole.

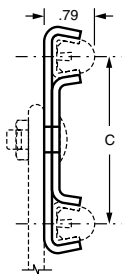
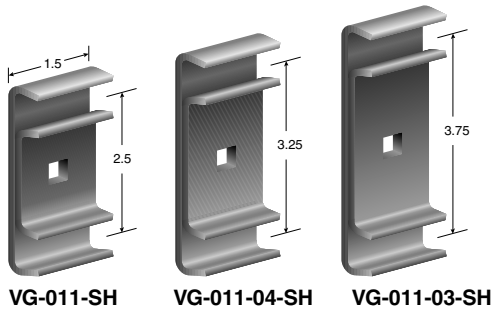

Part Number	(C) Rail Centers (in.)	Fastener
VG-011-SH	2.5	5/16 or M8
VG-011-04-SH	3.25	5/16 or M8
VG-011-03-SH	3.75	5/16 or M8



Double Rail Clamp

Round hole, 3 inches wide for splicing.

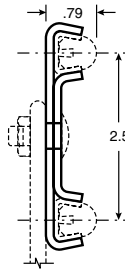
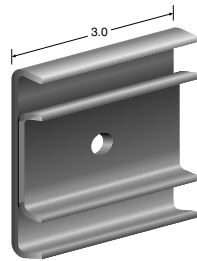

Part Number	Fastener
VG-011-WDR	3/8 or M10



Double Rail Clamp

Square hole, 3 inches wide for splicing.

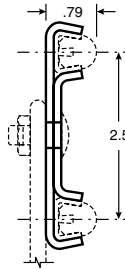
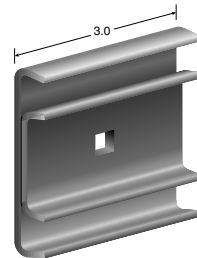

Part Number	Fastener
VG-011-WD	5/16 or M8

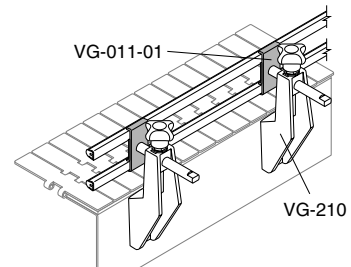
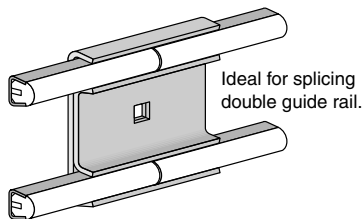



011

Double Rail Clamp
Slotted hole.

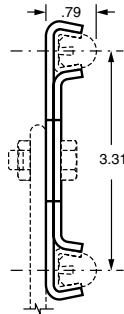
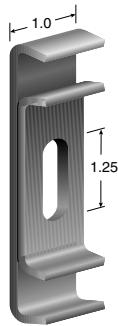

Material: Stainless steel, 11 gauge.

Part Number	Fastener
VG-011-NS	3/8 or M10



Guide Rails and Hardware

Triple Rail Clamp

Support for guide rail.
Used with tall containers or when large and small containers run on the same production line.



VG-011-02

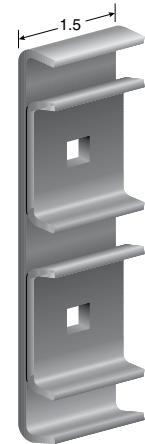

VG-011-02-SH

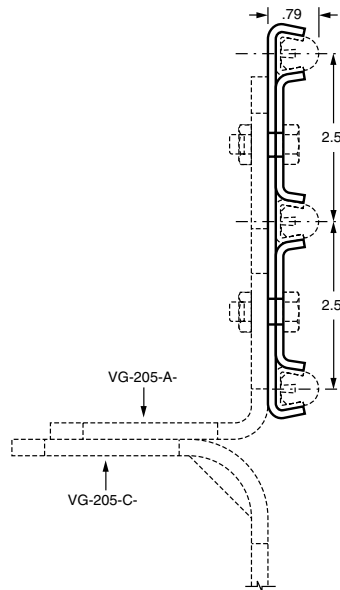

Material: Stainless steel, 11 gauge.

Part Number	Fastener
VG-011-02	3/8 or M10



VG-011-02-SH	5/16 or M8
---------------------	-------------------

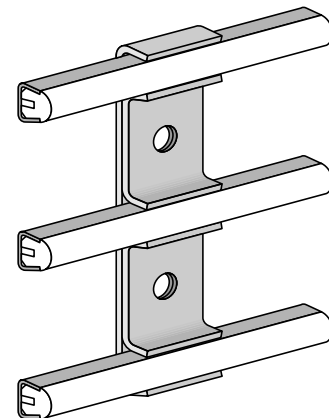
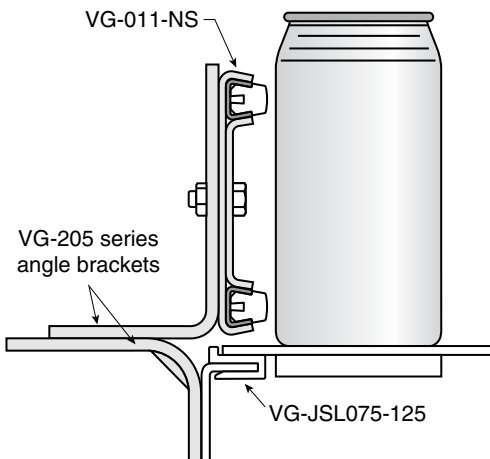



011-01-P

Plastic Double Rail Clamp for Rail or Rod

Support for Valu Guide rail or 1/2 in. round rod. Can be used with flat brackets up to 1-1/2 in. wide or with male or female adjusting rods. Two piece, self centering assembly.

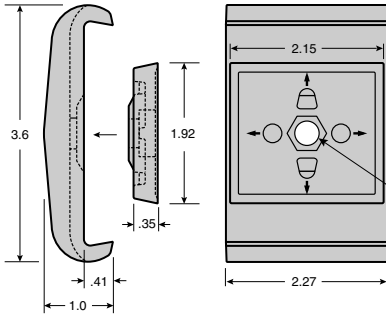

Material: Reinforced polyamide.

Part Number	Fastener
VG-011-01-P-38	3/8

For 1/2 inch round rod and additional clamps, see pg. 236-237

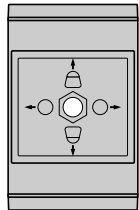
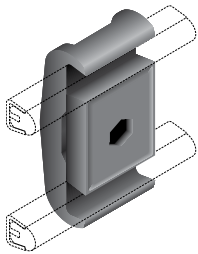
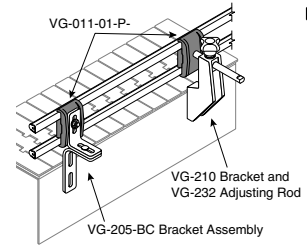

For Valu Guide rail

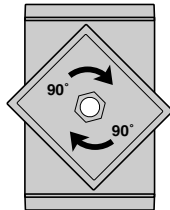

Rotate center piece 90°

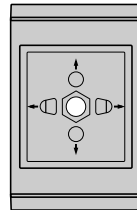

For 1/2 in. round rod

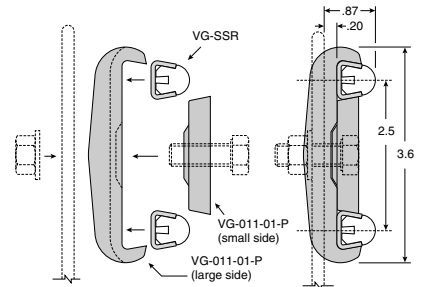
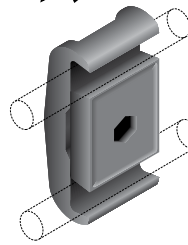

Guide Rails and Hardware

Stainless Steel Rods

Support rod options for use with VG-011-01-P- Plastic Rail Clamp.

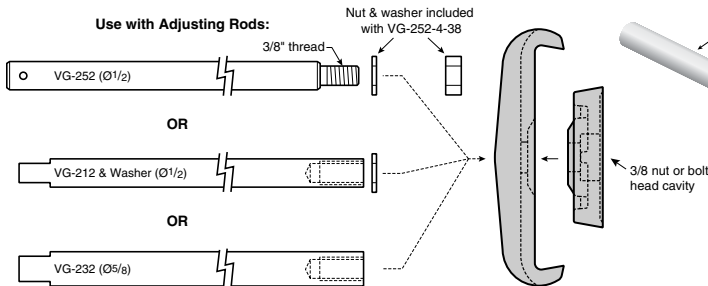

Washer recommended when using Ø1/2 rod.

Material: Stainless steel.

Part Number	Length (in.)	Fastener
VG-252-4-38	4	3/8
VG-212 Rods:	see page 296	
VG-232 Rods:	see page 296	

031



Rail Clamp and Metal Rod Combination

A double bolt clamp with increased grip strength. Clamp is molded onto 1/2 inch OD stainless steel tube, for a cost effective way to provide strong rail support. Special hardware keeps jaws assembled during rail attachment.

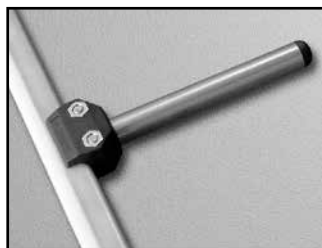

Quick Claw
Longer nut threads allow clamp to open while assembly stays intact!



Includes patented features. Patent No. 5,626,221

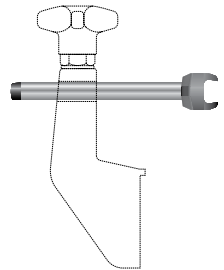

One-Piece, Integral Design!

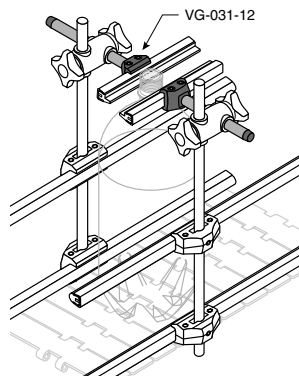
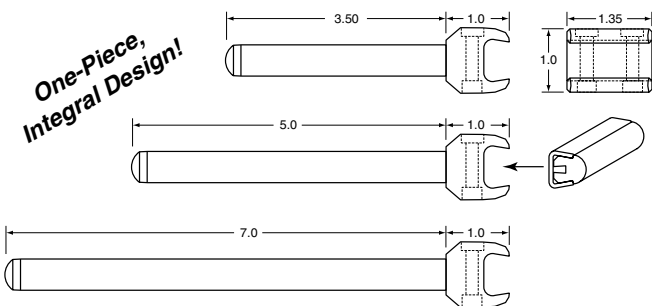

Material: Polyamide clamp with stainless steel rod, nickel plated brass and stainless steel fasteners.

Part Number	Rod Length (in.)
VG-031-12-35	3.5
VG-031-12-50	5.0
VG-031-12-70	7.0



022

Rail Clamp for Rod or Flat Bar

Mounts on flat bar up to 1/4 x 1 in. or rods up to 1/2 in. diameter. Versatile, corrosion resistant design easily adjusts and positions guide rails and sensor holders. The clamp can be opened enough to accommodate the rail while the fasteners remain engaged.



Quick Claw
Longer nut threads allow clamp to open while assembly stays intact!

Material: Polyamide clamp with nickel plated brass and stainless steel fasteners.

Part Number
VG-022-01

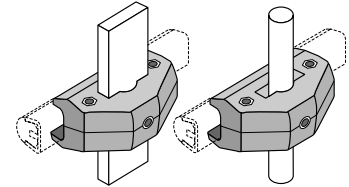

Guide Rails and Hardware



Patent No.
6,685,385
6,872,027, B2

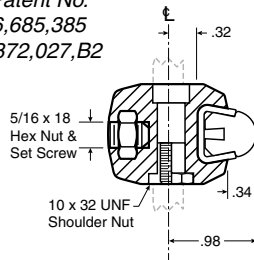
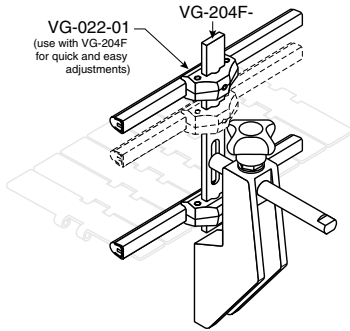
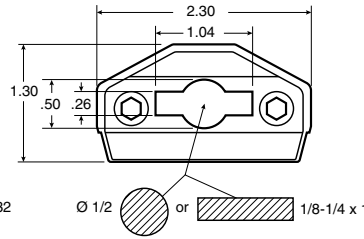

204F

Mounting Bar

Versatile and time saving, mounting bar positions guide rail. Can be used independently or in combination with VG-022 rail clamp and other various Valu Guide components. 3/8 carriage bolt and washer are included with each Mounting Bar.

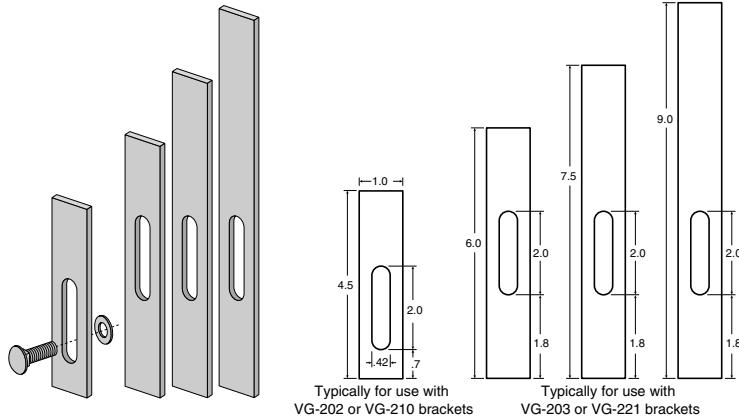

Material: Stainless steel, 3/16 x 1.

Part Number	Length (in.)
VG-204F-45-316S	4.5
VG-204F-60-316S	6.0
VG-204F-75-316S	7.5
VG-204F-90-316S	9.0

612

Sensor Mount

Accurately positions sensors and reflectors. Use with VG-022-01 rail clamp for ideal sensor mounting and quick adjustment, above or below guide rail.

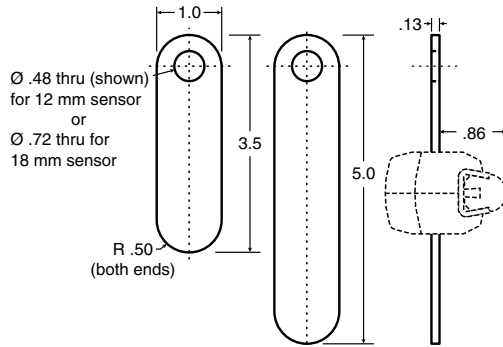
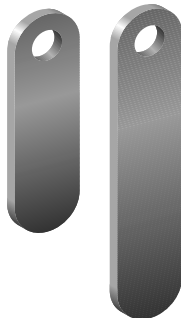

Material: Stainless steel.

Part Number	Length(in.)	Sensor(mm)
VG-612-35-12	3.5	12
VG-612-35-18	3.5	18
VG-612-50-12	5	12
VG-612-50-18	5	18

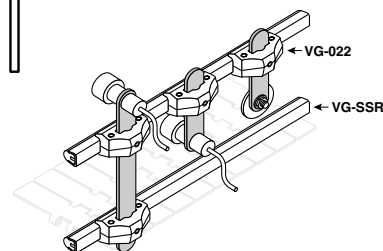



020

Rod End for Valu Guide Rail

Attaches to VG-020-R adjusting rods for use as a connector to hold and easily adjust Valu Guide rail.

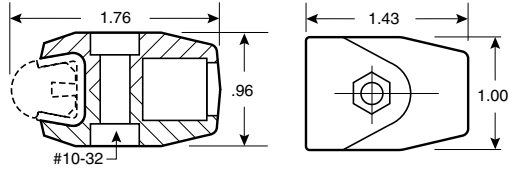

Material: Acetal clamp with nickel plated brass and stainless steel fasteners.

Part Number

VG-020-01

020-R

Adjusting Rods for Rod Ends

Polished stainless steel rod attaches to VG-019-12 or VG-020-01 rod ends. Holds Valu Guide rail firmly in position and adjusts quickly when required. Available in various lengths with 1/2 or 5/8 in. diameters.

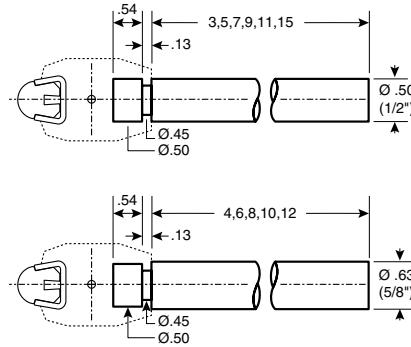
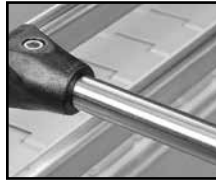
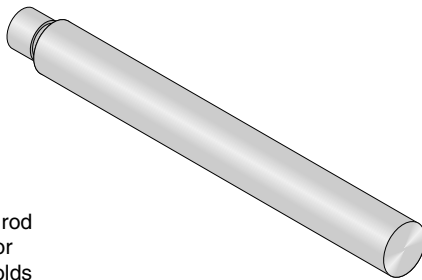

Material: Stainless steel.

Part Number Length (in.) Ø (in.)

VG-020-R3 3 1/2

VG-020-R5 5 1/2

VG-020-R7 7 1/2

VG-020-R9 9 1/2

VG-020-R11 11 1/2

VG-020-R15 15 1/2

VG-020-R4 4 5/8

VG-020-R6 6 5/8

VG-020-R8 8 5/8

VG-020-R10 10 5/8

VG-020-R12 12 5/8

020J

Jointed Adjusting Rods: Grooved

For use with Valu Guide Rod Ends (VG-019 or VG-020) as a connector for curved or angled guide rail.

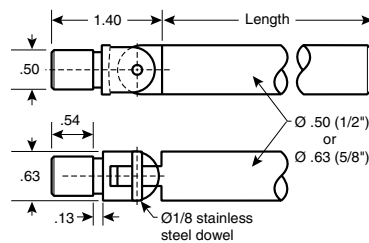
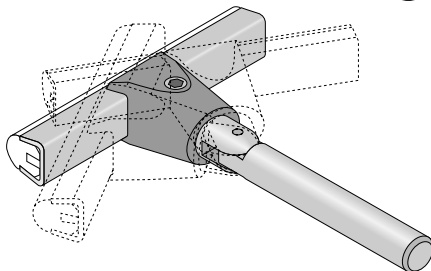
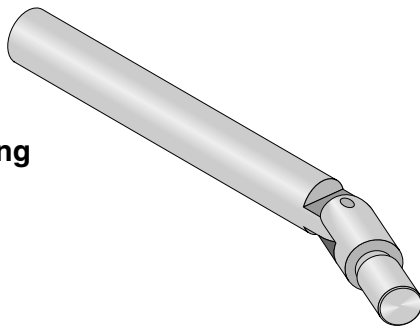

Material: Stainless steel.

Part Number Length (in.) Ø (in.)

VG-020J-R3 3 1/2

VG-020J-R4 4 5/8

VG-020J-R5 5 1/2

VG-020J-R6 6 5/8

VG-020J-R7 7 1/2

VG-020J-R8 8 5/8

VG-020J-R9 9 1/2

VG-020J-R10 10 5/8



3316

Swivel Clamp

Use as a connector for curved or angled guide rail.

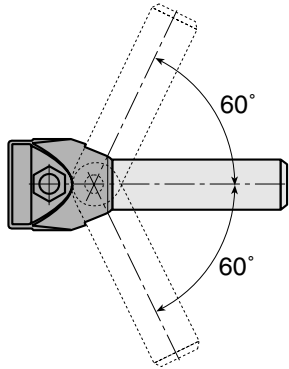
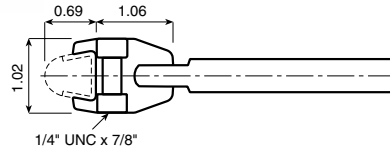
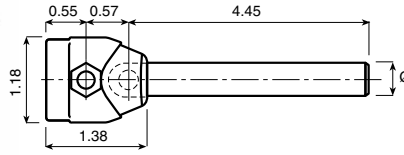

Material: Reinforced polyamide with stainless steel fasteners.

Part Number	Ø (in.)
33167	(clamp only)
33168A	1/2
33168B	5/8

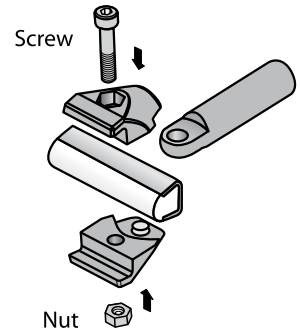

33928

Adjusting Rod for Rod End

Polished stainless steel rod attaches to 33167 rod end. Holds rail firmly in position and adjusts quickly when required.

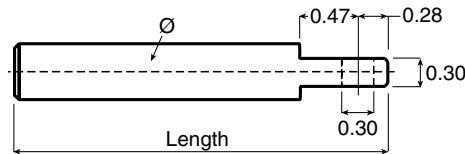
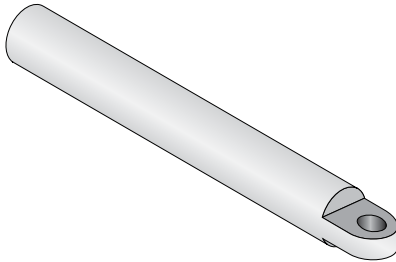

Material: Stainless steel.

Part Number	Length (in.)	Ø (in.)
33928	5	5/8



131170

Adjustable Guide Rail Clamp

Use as a connector for guide rail.

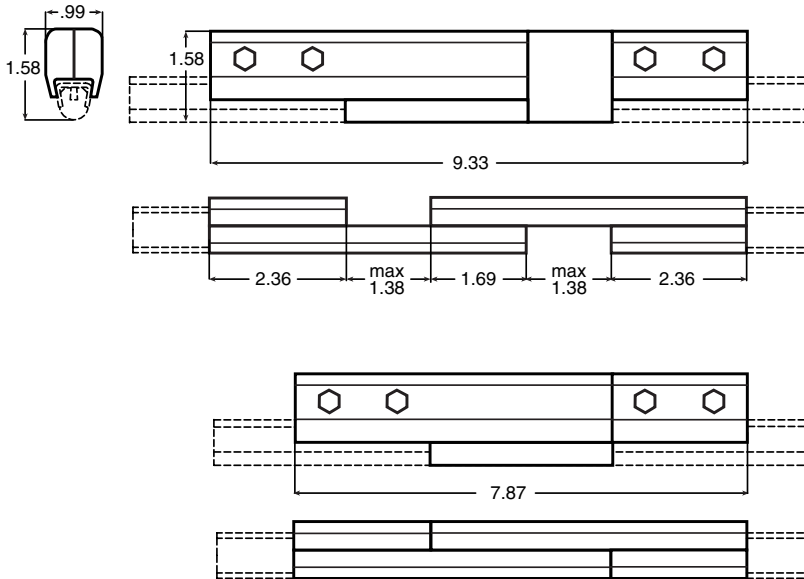

Material: Polyamide clamp with stainless steel and nickel plated brass fasteners.

Part Number	Guide Rail
131170	VG-SSR

Guide Rails and Hardware

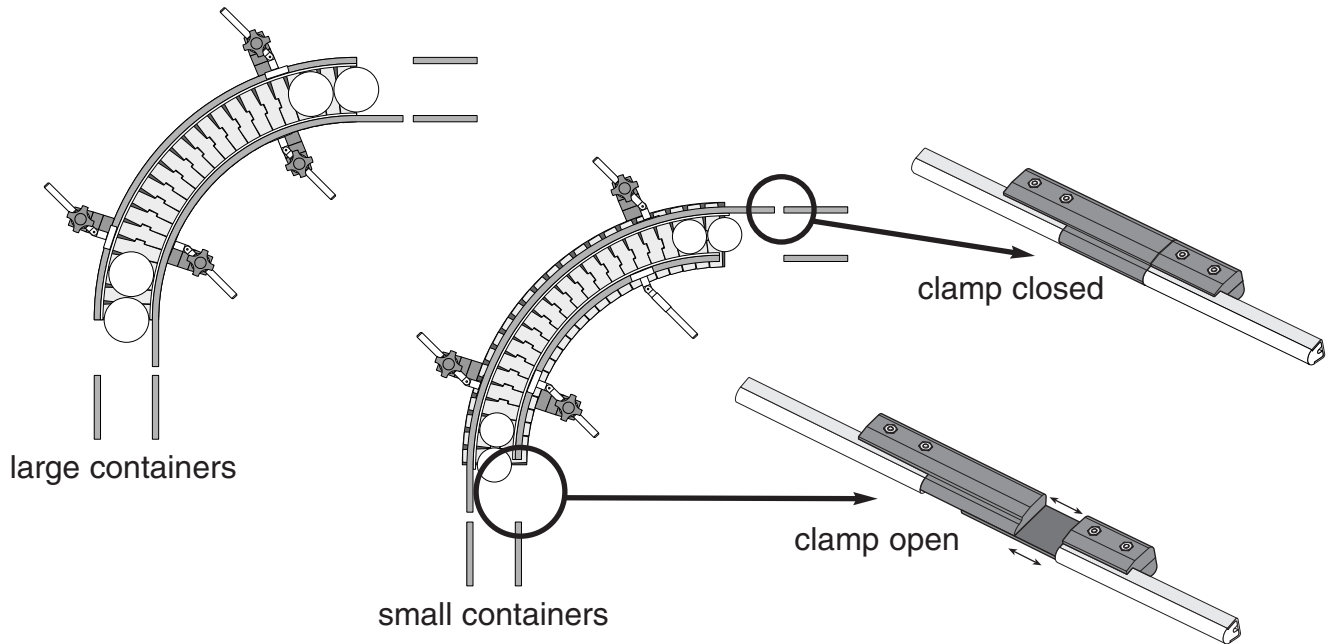

Rail Splicing Clamps

013

Splice Sleeve

Connects ends of two guide rails. This tight fitting sleeve can be tapped on with a hammer. No screws or bolts are necessary. For increased corrosion resistance, VG-013-01-316 is made from 316 stainless steel.

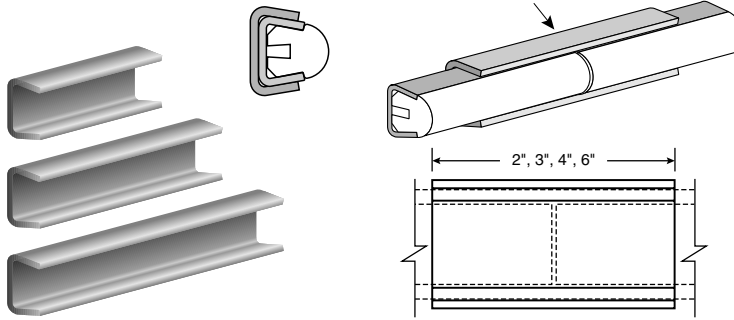

Material: Stainless steel, 14 gauge. VG-013-01-316 is 316 stainless steel.

Part Number	Length (in.)
VG-013-01	2
VG-013-01-316	2
VG-013-03	3
VG-013-06	6

Guide Rails and Hardware

113-01

Heavy Duty Clip

Two piece compression style for easy assembly and adjustment. Heavy duty, rigid support, installs easily over rail.

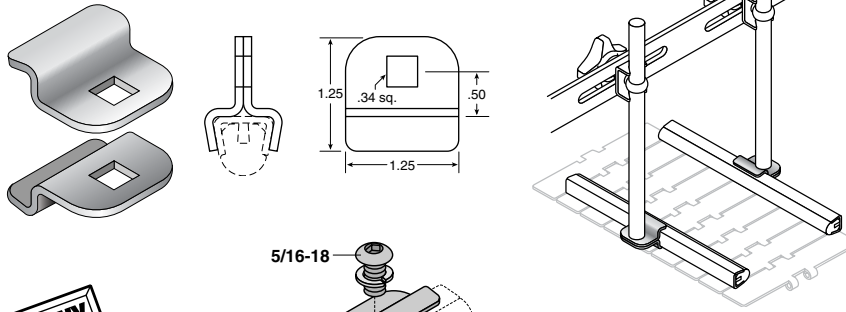

Material: Stainless steel, 13 gauge.

Part Number	Fastener
VG-113-01	5/16



113

Rail Splice Clamp

Connects ends of two guide rails. Heavy duty, rigid support resists bending, installs easily over rail. Patent pending. Hardware included.

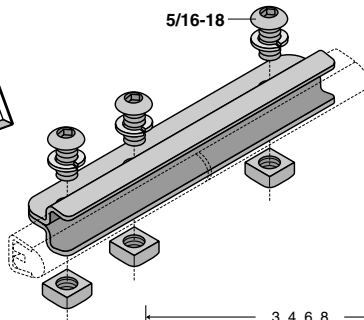

Patented Feature Patent No. 6,250, 841

Material: Stainless steel, 13 gauge.

Part Number	Length (in.)
VG-113-03	3
VG-113-04	4
VG-113-06	6
VG-113-08	8
VG-113-08G	Gap

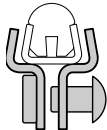

Before tightening

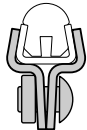

Jaws compress on rail



After tightening

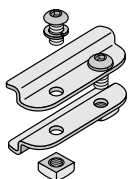

VG-113-03

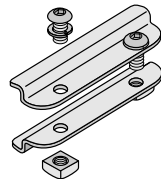

VG-113-04

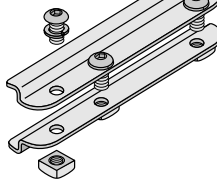

VG-113-06

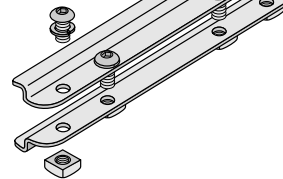

VG-113-08

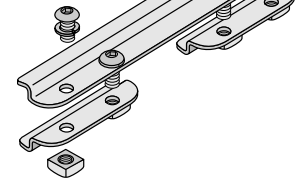

VG-113-08G

113S



Patent No. 6,053, 654

Sliding Splice Clamp

Used in situations such as radius turns where frequent adjustments are made. Allows one rail to slide within the clamp while the other remains fixed. With shim in place, clamp positions rail but allows sliding for adjustments up to 2 inches.

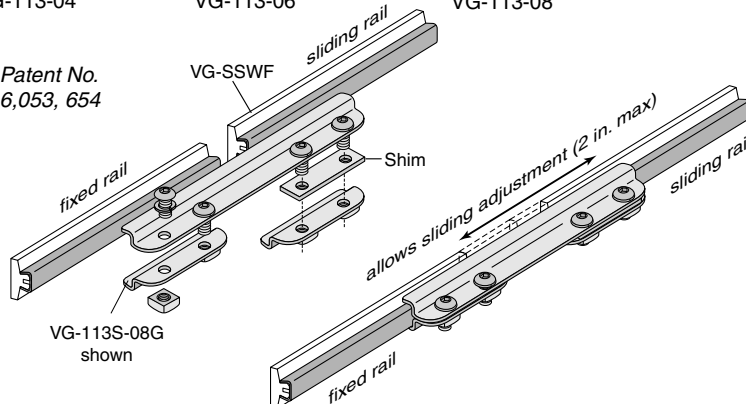

Material: Stainless steel.

Part Number	Length (in.)
VG-113S-06	6
VG-113S-08	8
VG-113S-08G	Gap

Rail Splicing Clamps



118

Rail Splice Clamp

Connects ends of two guide rails. Heavy duty, rigid support resists bending, installs easily over rail and can be bolted directly to a bracket. Patent pending. Hardware included.

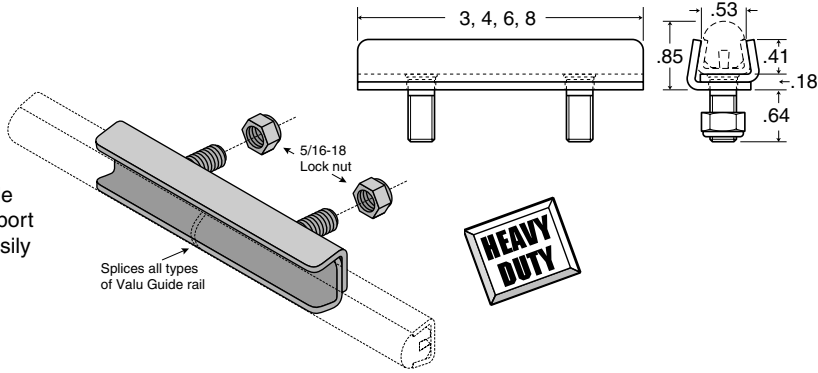

Material: Stainless steel, 13 gauge.

Part Number	Length (in.)
VG-118-03	3
VG-118-04	4
VG-118-04K Knob	4
VG-118-06	6
VG-118-06K Knob	6
VG-118-08	8
VG-118-08G Gap	8
VG-118M-04 M8 thread	4

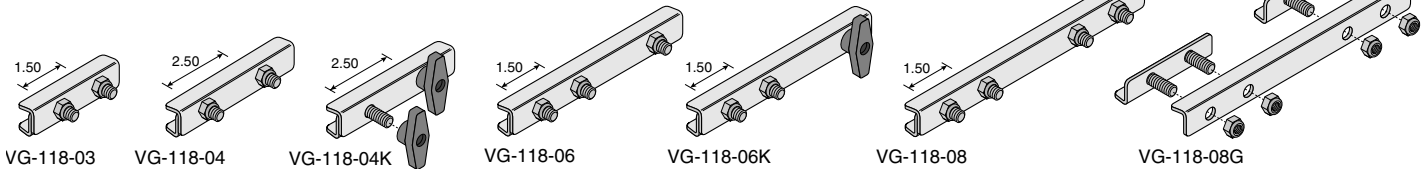
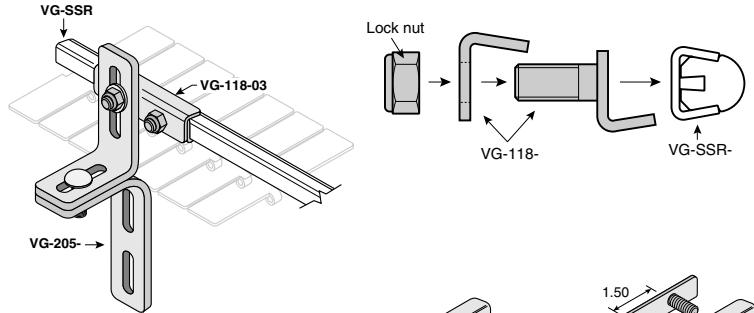
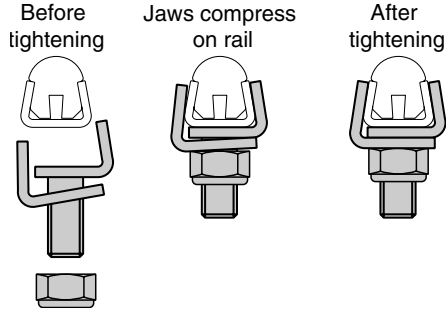

118B

Guide Rail Bridge Kit

Provides continuity in side guide surface by bridging a gap that is sometimes created when adjusting rails for larger container sizes.

Kit includes:

- 1 - VG-118
- Bridge Plate
- 2 - VG-018-01
- 6" piece chamfered rail
- Hardware

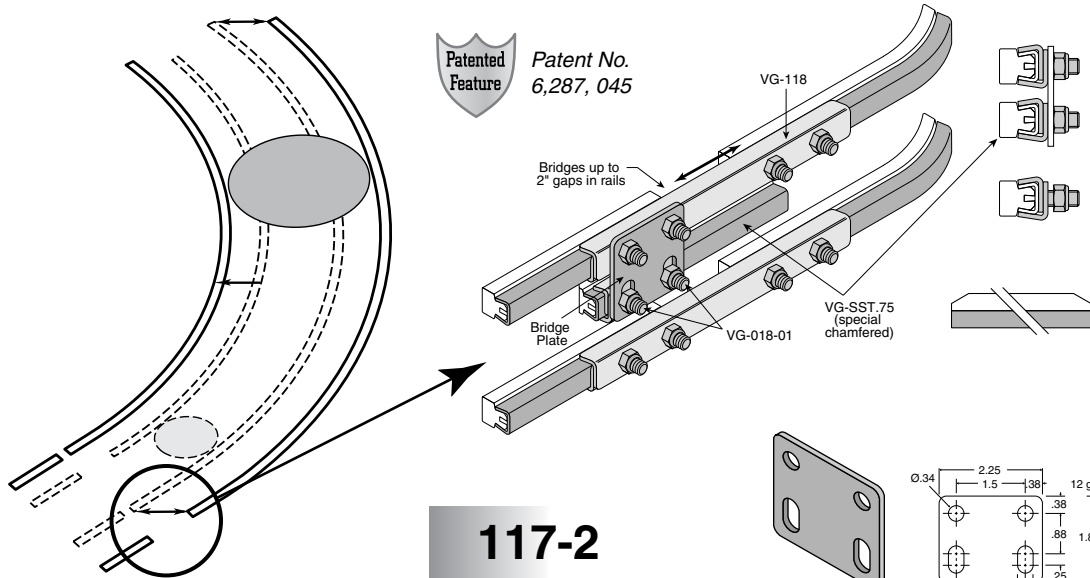

Part Number	Rail	Length(in.)
VG-118B-06R	VG-SSR	6
VG-118B-06T	VG-SST.75	6
VG-118B-08R	VG-SSR	8
VG-118B-08T	VG-SST.75	8

Note: Use "R" rail to bridge Round, Modified and Flat profiles. Use the "T" for all other Tee profiles.

117-2

Universal Mounting and Splice Plates

Individual stainless plates for various mounting and splicing uses.

Material: Stainless steel.

Part Number	H	W
VG-117-2-2	1.88	2.25
VG-117-2-4	4.25	2.25

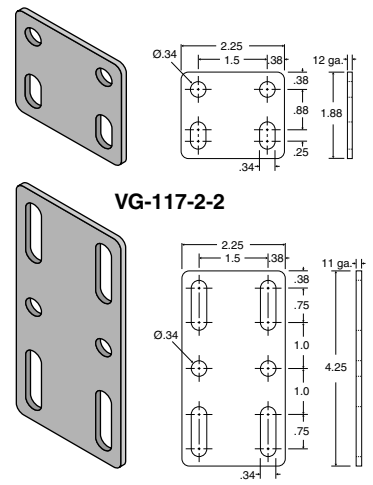

VG-117-2-4



Rail Clips

018

Heavy Duty Clip

Heavy duty support for guide rail. Two piece compression style for easy assembly and adjustment. Works with brackets, support beams and adjusting rods. Available in 4 stud lengths. The VG-018 offers excellent corrosion resistance. Recommended max. torque: 17 ft-lbs or 23 N•m.



Material: 13 ga. stainless steel.

Part Number	Bolt Length (L)	Thread
VG-018-01	.675	5/16
VG-018-02	.75	5/16
VG-018-03	1.0	5/16
VG-018-04	1.25	5/16
VG-018M-01	15mm	M8
VG-018M-02	20mm	M8
VG-018M-03	25.5mm	M8
VG-018M-04	30mm	M8

Guide Rails and Hardware

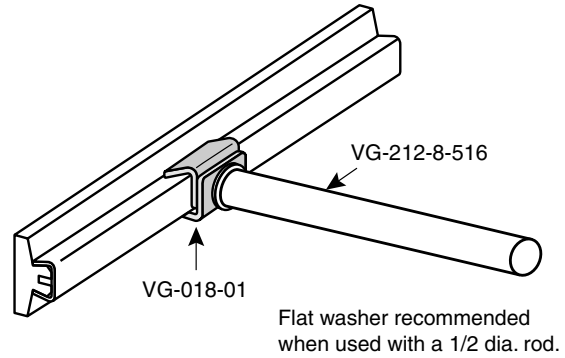
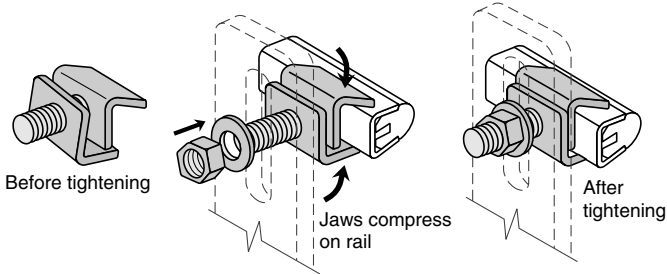
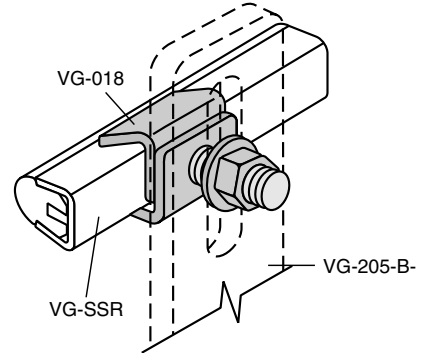
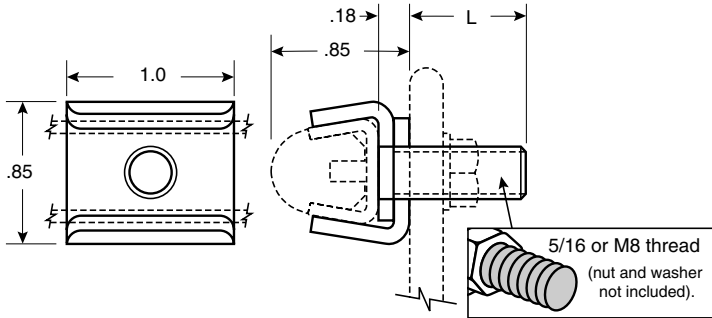

014H

Self Tightening Clip

Medium duty clip for supporting guide rails. Jaws of clip open for easy attachment then clamp onto rail when tightened. This is an upgrade from the standard VG-014 clip. Nut not supplied. Recommended torque: 10ft-lb.



Material: Stainless steel, 14 ga.

Part Number	Bolt Length (L)	Thread
VG-014H-01	.60	1/4
VG-014H-02	.85	1/4

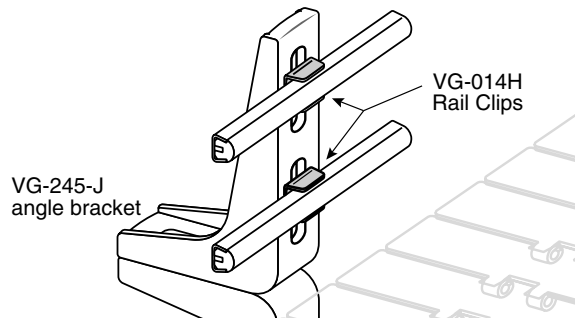
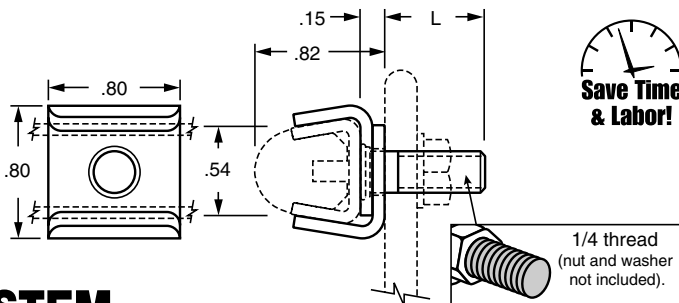



015

Self Tightening Clip

Heavy duty support for guide rail. Automatically clamps onto Valu Guide rail when the bolt is tightened. Available in 4 bolt lengths, the VG-015 clip saves assembly time and can be used with brackets or support beams. Recommended max. torque: 19 ft-lbs or 26 N•m.



Patent No. 5,803,687

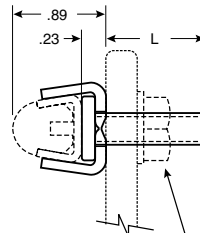
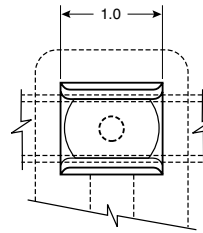

5/16 or M8 thread (nut and washer not included).

Material: Stainless steel, 13 ga.

Part Number	Bolt Length (L)	Thread
VG-015-01	.64	5/16
VG-015-02	.76	5/16
VG-015-03	1.01	5/16
VG-015-04	1.26	5/16
VG-015M-01	16mm	M8
VG-015M-02	19mm	M8
VG-015M-04	32mm	M8

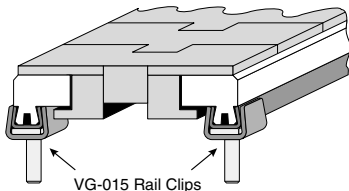

Shown with VG-SSTG/GSTG-02 Tab Chain Guide Rail

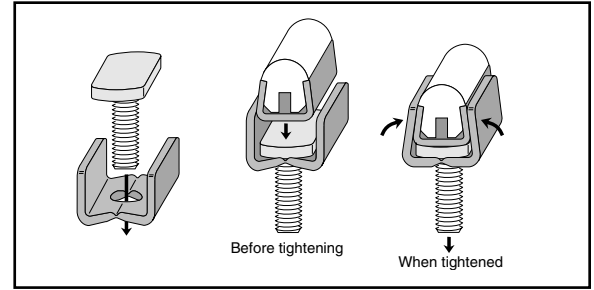
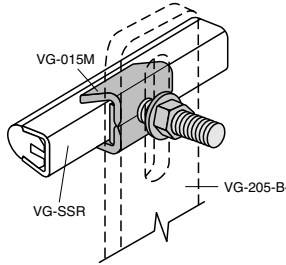

Guide Rails and Hardware

016

Aluminum Compression Clip

Heavy duty support for guide rail. Can be used on most industrial applications. Clip grips onto rail when the bolt is tightened.

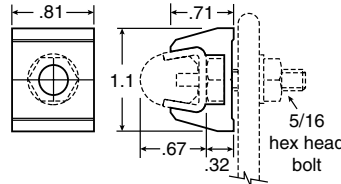

VG-017 Backing Plate is required when attaching to an adjusting rod.

Material: Aluminum or anodized aluminum.

Part Number	Aluminum	Anodized	Fastener
VG-016-01	•		5/16
VG-016-03		•	5/16

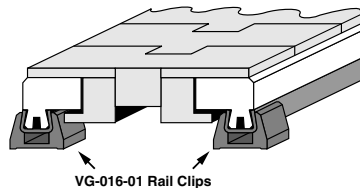

VG-016-01 Rail Clips

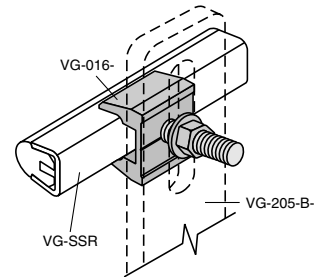

017

Backing Plate

Makes VG-016 close tightly onto rail when used for rod end applications.

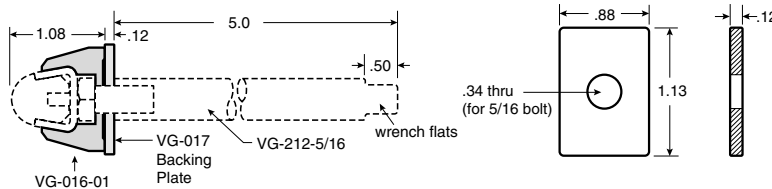

Material: Stainless steel.

Part Number

VG-017

016



Plastic Compression Clip

For light duty applications. Connects guide rail to brackets or adjusting rods. When the clip is installed loose, the rail can be snapped into the clip. As the bolt is tightened, clamping force on the rail increases.

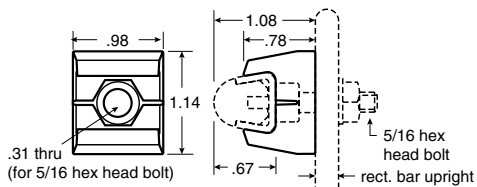

Material: Acetal.

Part Number

VG-016-02



Not recommended for use with adjusting rods or on wear beds.

Round Guide Rail and Clamps

011-01-P

Plastic Double Rail Clamp for Rod or Rail

Support for 1/2 in. round rod or Valu Guide rail. Can be used with flat brackets up to 1-1/2 in. wide or with male or female adjusting rods. Two piece, self centering assembly.

Material: Reinforced polyamide.

Part Number	Fastener
VG-011-01-P-38	3/8

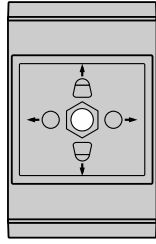
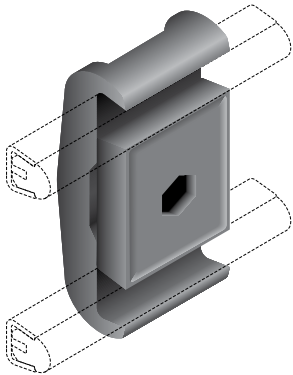
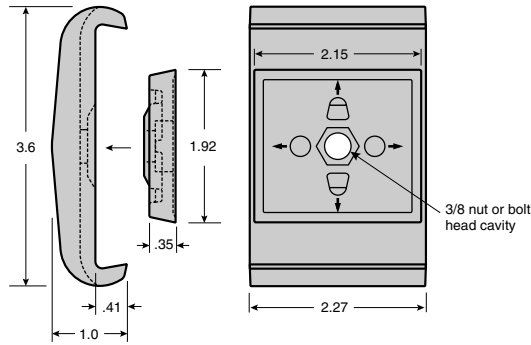

For Valu Guide rail

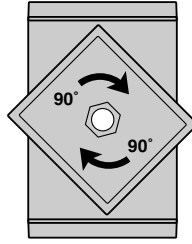

Rotate center piece 90°

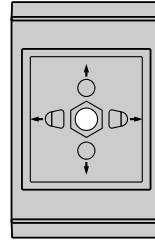

For 1/2 in. round rod

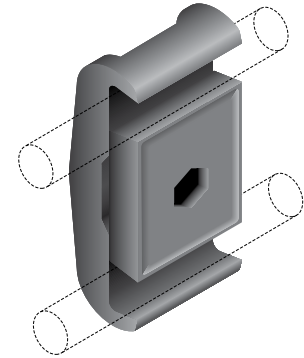

021

Rod Clamp for Rod or Flat Bar

Mounts on flat bar up to 1 x 1/4 in. or rods up to 1/2 in. diameter. Corrosion resistant design easily adjusts and positions 3/8 or 1/2 in. diameter rods.

Quick Claw
Longer nut threads allow clamp to open while assembly stays intact!



Material: Polyamide clamp with nickel plated brass and stainless steel fasteners.

Part Number	Rod Dia. (in.)
VG-021-02	1/2

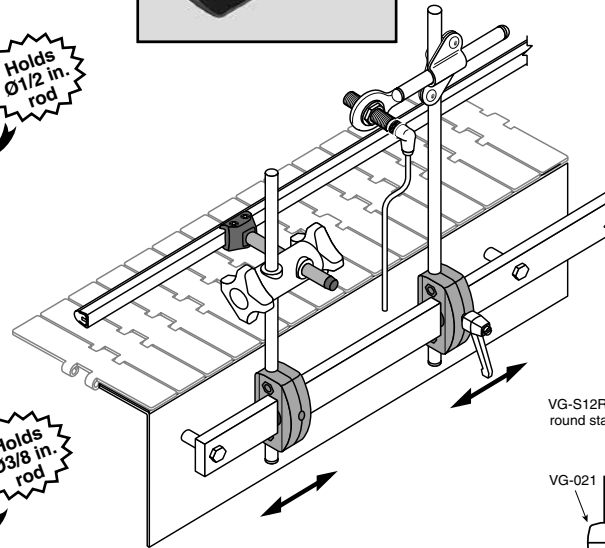
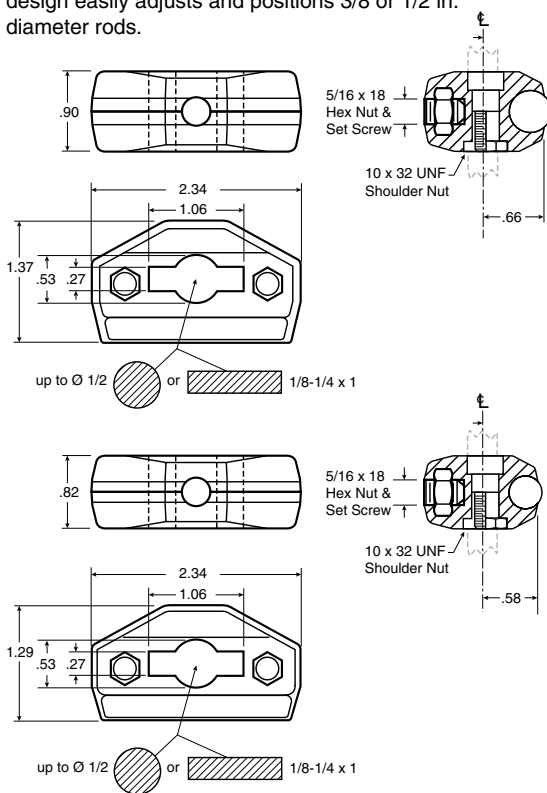

Patent No. 6,685,385

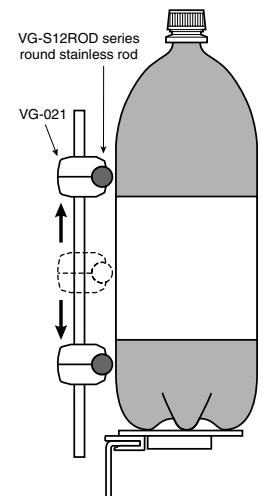
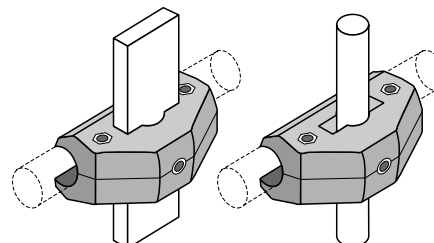

SYSTEM PLAST™

©2015 Regal-Beloit Corporation, All Rights Reserved.



032

Clamp and Metal Rod Combination for Round Rod

A double bolt clamp with increased grip strength. Clamp is molded onto 1/2 inch OD stainless steel tube, for a cost effective way to provide strong rod support. Special hardware keeps jaws assembled during rod attachment.



Quick Claw
Longer nut threads allow clamp to open while assembly stays intact!

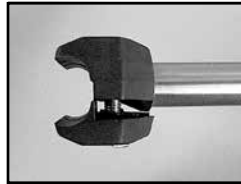

Includes patented features. Patent No. 5,626,221

One-Piece, Integral Design!

Material: Polyamide clamp with stainless steel rod, nickel plated brass and stainless steel fasteners.

Part Number	Rod Length (in.)
VG-032-12-35	3.5
VG-032-12-50	5.0
VG-032-12-70	7.0

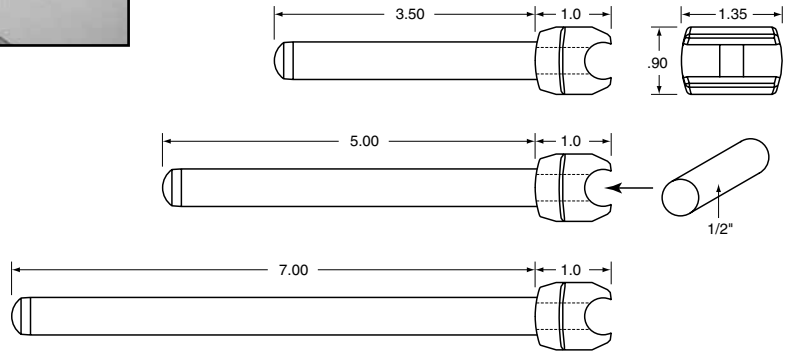

Guide Rails and Hardware

019

Rod End

Attaches to VG-020-R adjusting rods for use as a connector to hold and easily adjust 1/2 round guide rod.

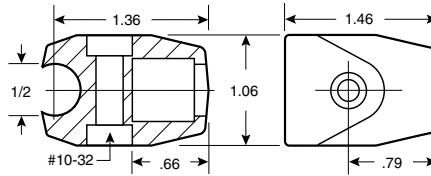

Material: Acetal clamp with stainless steel and nickel plated brass fasteners.

Part Number
VG-019-12

Quick Claw
Longer nut threads allow clamp to open while assembly stays intact!

See page 229 for adjusting rod information

Valu Guide's selection of holding devices for round rod can be used in many different applications. Although side guide rail is a common use for round rod, these versatile clamps can hold and adjust round rod vertically for additional positioning options.

S12ROD

Steel Rod

Polished stainless steel rod, 1/2 inch diameter. Used as a side guide or as a vertical positioning support.

See page 262 for 1/2" UHMW round bar.

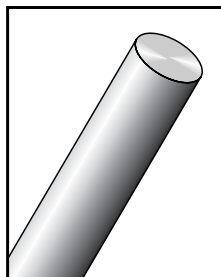

Material: Stainless steel.

Part Number	Length (ft.)
VG-S12ROD-8	8
VG-S12ROD-12	12

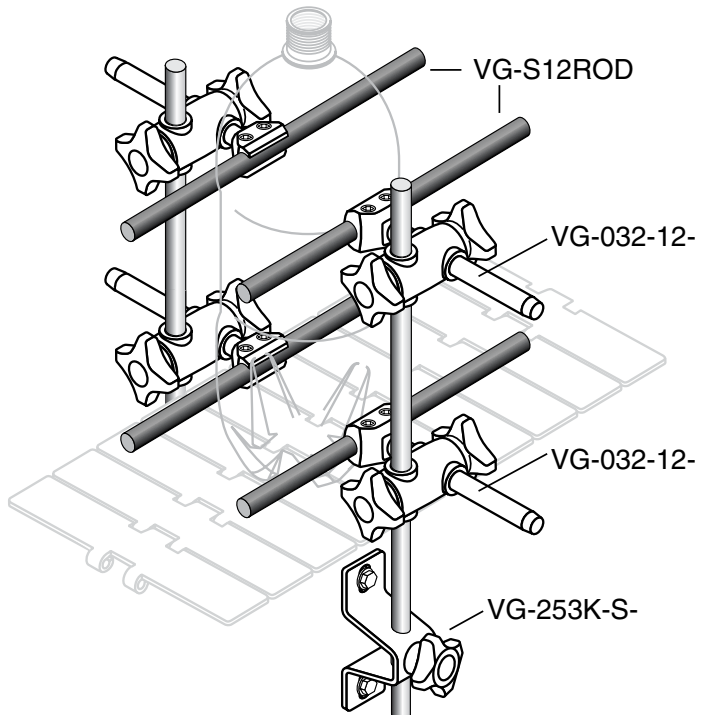

SYSTEM PLAST™

Wide Guide™ Rail and Clamps

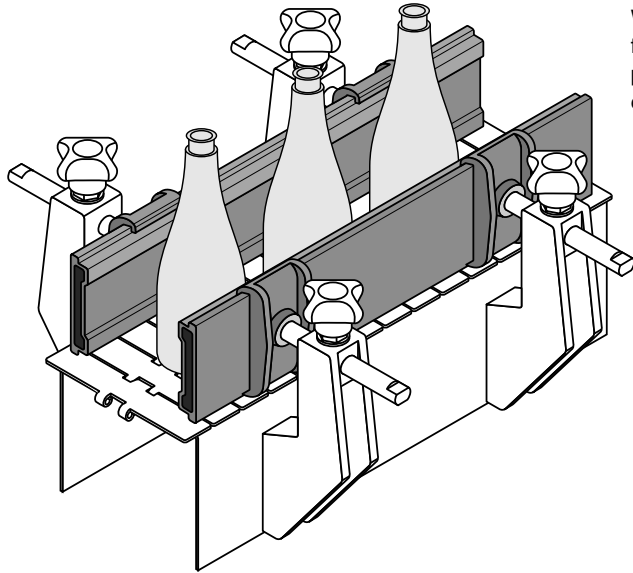

Wide Guide™ is a non-corrosive, easy to bend side guide for package or container conveying. Complete with compatible clamps and adjusting rods, Wide Guide™ is a cost effective alternative to other multi-rail systems.

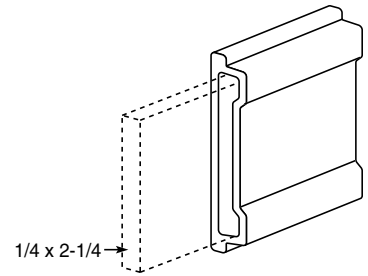

For added support with heavy side loads or in corner applications, Wide Guide™ is used in conjunction with a customer supplied internal bar or structural channel.

Guide Rails
and Hardware

19082

Wide Guide

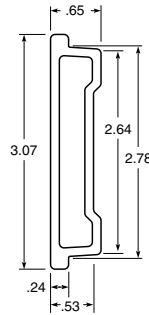
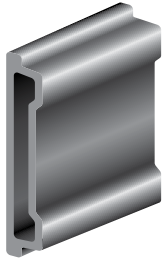

Material: Black or blue Polyethylene

Part Number	Color	Length
19082L	black	3m
19082	black	6m
19082BL	blue	3m
19082B	blue	6m

190

Wide Guide
Clamp

For use with Wide
Guide profile 19082.

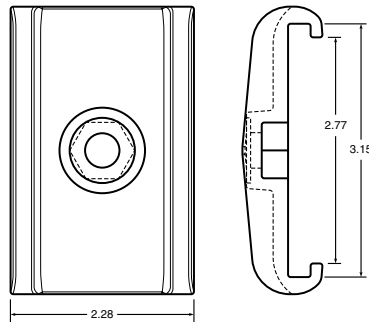

Material: Black Polyamide clamp with stainless steel washer.

Part Number	Nut Cavity Size
VG-190	M10
VG-190-38	3/8



191

Wide Guide
Clamp with Rod

For use with Wide
Guide profile 19082.

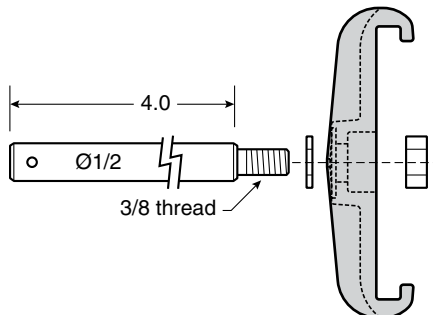

Material: Black Polyamide clamp with stainless steel washer, rod and nut.

Part Number	Ø Rod	Length
VG-191-252-4	1/2	4



**SYSTEM
PLAST™**

©2015 Regal-Beloit Corporation, All Rights Reserved.



19050

Wide Guide

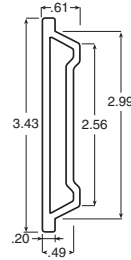
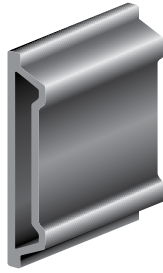

Material: Black or blue Polyethylene

Part Number	Color	Length
19050L	black	3m
19050	black	6m

1371

Wide Guide
Clamp

For use with Wide
Guide profile 19050.

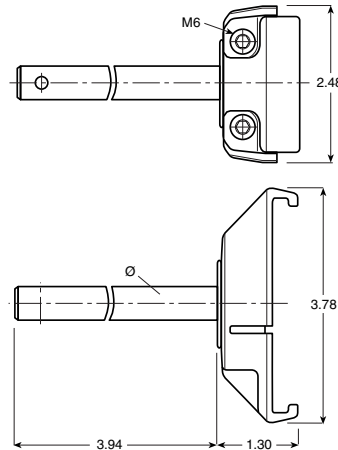

Material: Black Polyamide clamp with
stainless steel bolt, rod and washer.

Part Number	Ø Rod
13718	-
13715	1/2
13716	9/16
13717	5/8

19098

Wide Guide

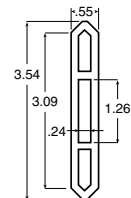

Material: Green Polyethylene

Part Number	Color	Length
19098	green	6m

13982

Fixing Clamp

For use with Wide
Guide profile 19098.

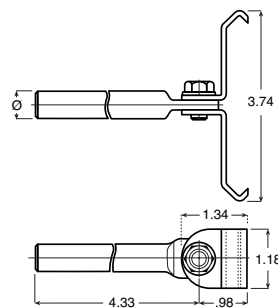

Material: Stainless steel clamp, rod,
and screw.

Part Number	Ø Rod
13982	1/2

Guide Rails
and Hardware



190 series

Side Guides

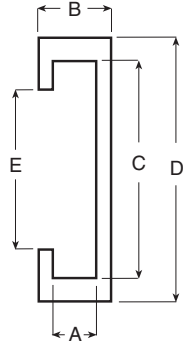

Guide Rails
and Hardware

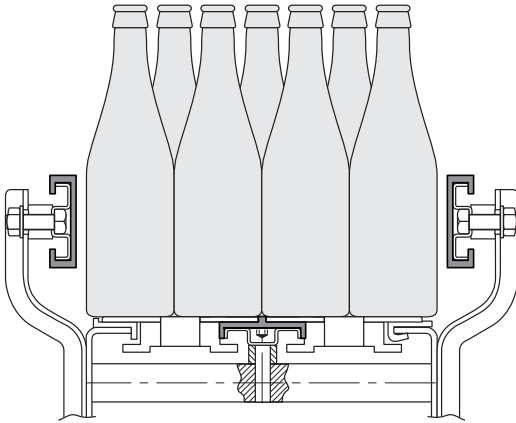

Material: Black or green Polyethylene.

Part Number	A	B	C	D	E	Color	Length
19080N*	.26	.47	1.61	1.97	1.18	black	3m
19080NL*	.26	.47	1.61	1.97	1.18	black	6m
19080V*	.26	.47	1.61	1.97	1.18	green	3m
19080VL*	.26	.47	1.61	1.97	1.18	green	6m
19053N**	.34	.55	1.61	1.97	1.08	black	3m
19053NL**	.34	.55	1.61	1.97	1.08	black	6m
19053V**	.34	.55	1.61	1.97	1.08	green	3m
19053VL**	.34	.55	1.61	1.97	1.08	green	6m
19081N***	.41	.63	1.61	1.97	1.38	black	3m
19081NL***	.41	.63	1.61	1.97	1.38	black	6m
19081V***	.41	.63	1.61	1.97	1.38	green	3m
19081VL***	.41	.63	1.61	1.97	1.38	green	6m
19052N	.26	.47	2.01	2.36	1.42	black	3m
19052NL	.26	.47	2.01	2.36	1.42	black	6m
19052V	.26	.47	2.01	2.36	1.42	green	3m
19052VL	.26	.47	2.01	2.36	1.42	green	6m

* Can also be used with 19077 M-Profile on page 276.

** Can also be used with 190265 M-Profile on page 276.

*** Can also be used with 19079 M-Profile on page 276.

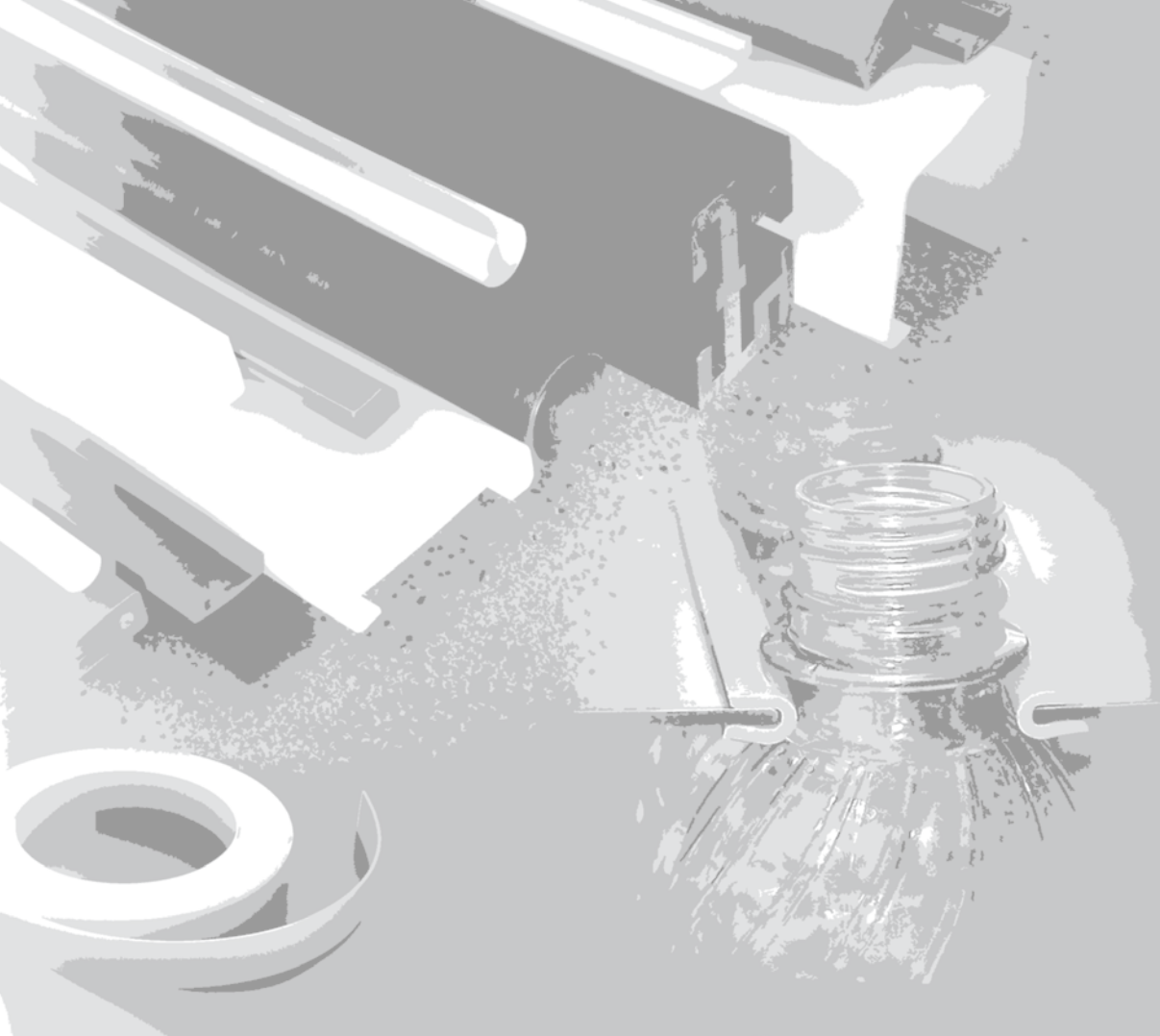

UHMW COVERS & ALUMINUM RAILS

Section 4

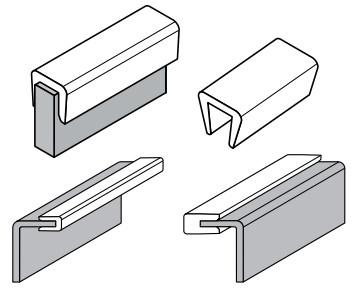

Bar Caps..... Page 242

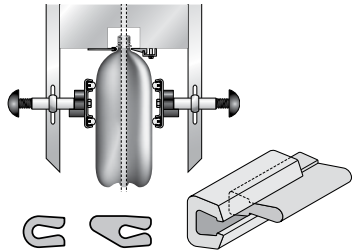

Neck and Bottle Guides Page 246

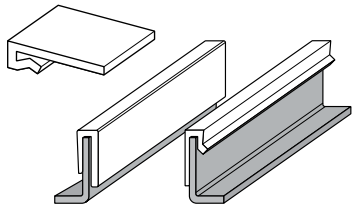

J-Leg Profiles... Page 248

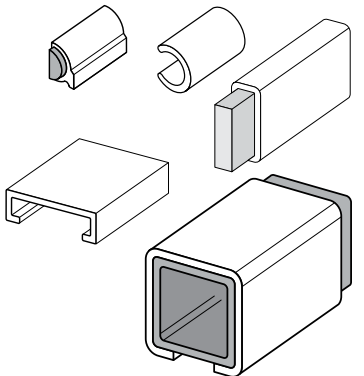

Bar and Tube Covers Page 252

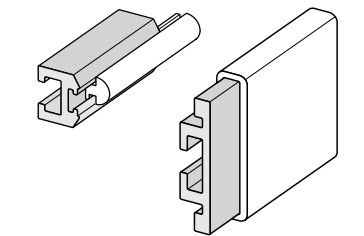

UHMW Covers & Aluminum Rails Page 257



Bar Caps

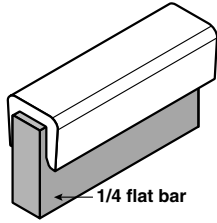

These low friction, wear resistant UHMW caps are designed to clip onto various thicknesses of flat bar material. Applications include conveyor belt supporting and conveyor side or neck guides.

1/16"
or
16 ga.



P116SBC

Clips onto 1/16 in. or 16 ga. flat bar. Can be used as a standard belt support.

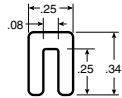

Material: UHMW

Part Number	Length (ft.)
VG-P116SBC-10	10
VG-P116SBC-20	20
VG-P116SBC-100	100*
VG-P116SBC-250	250*

1/8"
12 ga.
11 ga.



CSI

Clips onto 12 ga. or 11 ga. flat bar. Can be used as a special belt support or neck guide.

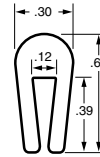

Material: UHMW

Part Number	Length (ft.)
VG-CSI-538-10	10
VG-CSI-538-20	20
VG-CSI-538-100	100*
VG-CSI-538-250	250*

P104D

Clips onto 1/16 in. or 16 ga. flat bar. Can be used for heavy duty applications.

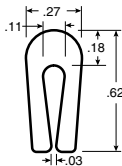

VG-P104D-10	10
VG-P104D-20	20
VG-P104D-100	100*
VG-P104D-250	250*

P204

Clips onto 1/8 in., 12 ga., or 11 ga. flat bar. Can be used as a special belt support.

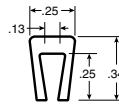

Material: UHMW or Grey Nolu-S.

Part Number	UHMW	Nolu-S	Length (ft.)
VG-P204-10	•		10
VG-P204-20	•		20
VG-P204-NS-100		•	100*
VG-P204-NS-250		•	250*

P116HD

Clips onto 1/16 in. or 16 ga. flat bar. Can be used as a narrow belt support or for other heavy duty applications.

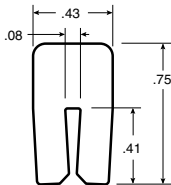

VG-P116HD-10	10
VG-P116HD-20	20

P18SBC

Clips onto 1/8 in., 12 ga., or 11 ga. flat bar. Can be used as a standard belt support.

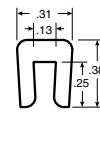

VG-P18SBC-10	10
VG-P18SBC-20	20
VG-P18SBC-100	100*
VG-P18SBC-250	250*

P18BC

Clips onto 1/8 in., 12 ga., or 11 ga. flat bar. Can be used for standard applications.

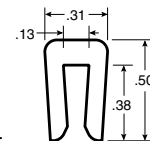

VG-P18BC-10	10
VG-P18BC-20	20
VG-P18BC-100	100*
VG-P18BC-250	250*

3/32"
or
13 ga.



P105R

Clips onto 3/32 in. or 13 ga. flat bar. Can be used as a neck guide.

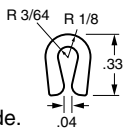

Material: Grey Nolu-S or Grey Nolu-SR.

Part Number	Nolu-SR	Nolu-S	Length (ft.)
VG-P105R-100	•		100*
VG-P105RCL-100	•		100*
VG-P105R-250	•		250*
VG-P105RCL-250	•		250*

Nolu-SR helps guide PET containers in high speed applications.

P18HD

Clips onto 1/8 in., 12 ga., or 11 ga. flat bar. Can be used as a narrow belt support or for other heavy duty applications.

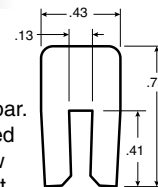

Material: UHMW or Grey Nolu-S.

Part Number	UHMW	Nolu-S	Length (ft.)
VG-P18HD-NS-10	•		10
VG-P18HD-NS-20	•		20
VG-P18HD-100	•		100*
VG-P18HD-250	•		250*

*Extruded profiles stored in coils will have the tendency to retain a certain deformation when uncoiled, therefore consistency in the profile cross section over the full length of the coil cannot be guaranteed.



1/8"
12 ga.
11 ga.

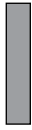

P1345

Clips onto 1/8 in., 12 ga., or 11 ga. flat bar. Can be used for belt retention or support.

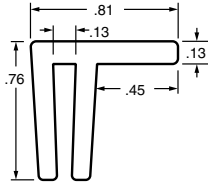

Material: UHMW

Part Number	Length (ft.)
VG-P1345-10	10
VG-P1345-20	20



Shipping Information: UHMW covers and inserts are typically shipped straight in tubes. 8' lengths can be shipped UPS. Standard 10' or 20' lengths are shipped by common carrier. Selected items can be coiled into cartons for more convenient shipping.

Extended Coil Lengths: Items marked with this symbol are available in continuous lengths of 100' or more. These items must be coiled for shipping and handling.

3/16"
or
7 ga.



P316BC

Clips onto 3/16 flat bar. Can be used as a standard belt support.

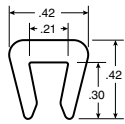

Material: UHMW

Part Number	Length (ft.)
VG-P316BC-10	10
VG-P316BC-20	20
VG-P316BC-100	100*
VG-P316BC-250	250*



P316HD

Clips onto 3/16 flat bar. Can be used as a heavy duty belt support.

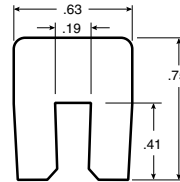

Material: UHMW

Part Number	Length (ft.)
VG-P316HD-10	10
VG-P316HD-20	20

P316SBC

Clips onto 3/16 flat bar. Can be used as a standard belt support.

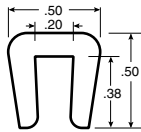

VG-P316SBC-10	10
VG-P316SBC-20	20
VG-P316SBC-100	100*
VG-P316SBC-250	250*



P7GABC

Clips onto 7 ga. steel. Can be used as a standard belt support. KVP equivalent wearstrip.

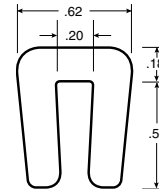

VG-P7GABC-10	10
VG-P7GABC-20	20
VG-P7GABC-100	100*
VG-P7GABC-250	250*



P316TBC

Clips onto 3/16 flat bar. Can be used as a standard belt support.

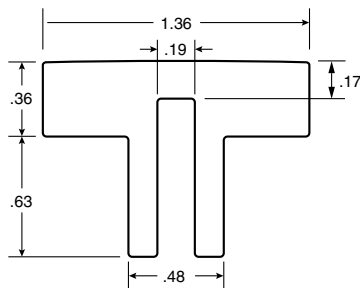

VG-P316TBC-10	10
VG-P316TBC-20	20

P7GAHD

Clips onto 7 ga. steel. Can be used for belt retention or support. KVP equivalent wearstrip.

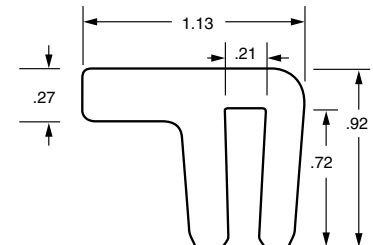

VG-P7GAHD-10	10
VG-P7GAHD-20	20

Options available for most wear strips:



Nolu-S UHMW:
(reduced friction)
add "-NS-" to
part number



Static Dissipative
UHMW:
add "-SD-" to
part number



Nolu-SR
UHMW:
add "-SR-" to
part number

Example: \downarrow
VG-P316HD-NS-10

*Extruded profiles stored in coils will have the tendency to retain a certain deformation when uncoiled, therefore consistency in the profile cross section over the full length of the coil cannot be guaranteed.



Bar Caps

6 mm



PM6BC

Clips onto 6 mm flat bar. Can be used as a standard belt support.

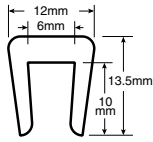

Material: UHMW

Part Number	Length (ft.)
VG-PM6BC-10	10
VG-PM6BC-20	20
VG-PM6BC-100	100*
VG-PM6BC-250	250*

Options available for most wear strips:



Nolu-S UHMW:
(reduced friction)
add "-NS-" to
part number



Static Dissipative
UHMW:
add "-SD-" to
part number



Nolu-SR
UHMW:
add "-SR-" to
part number

Example: \Downarrow
VG-P316HD-NS-10

UHMW Covers &
Aluminum Rails

1/4"



P14TBC

Clips onto 1/4 flat bar. Can be used as a special belt support.

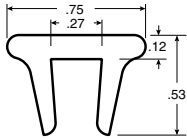

VG-P14TBC-10	10
VG-P14TBC-20	20
VG-P14TBC-100	100*
VG-P14TBC-250	250*

P14BC

Clips onto 1/4 flat bar. Can be used as a standard belt support.

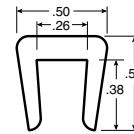

Material: UHMW

Part Number	Length (ft.)
VG-P14BC-10	10
VG-P14BC-20	20
VG-P14BC-100	100*
VG-P14BC-250	250*

P14SBC

Clips onto 1/4 flat bar. Can be used as standard belt support.

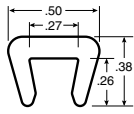

VG-P14SBC-10	10
VG-P14SBC-20	20
VG-P14SBC-100	100*
VG-P14SBC-250	250*

P14HD

Clips onto 1/4 flat bar. Can be used as a heavy duty belt support.

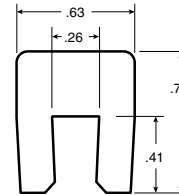

Material: Grey Nolu-S

Part Number	Length (ft.)
VG-P14HD-NS-10	10
VG-P14HD-NS-20	20

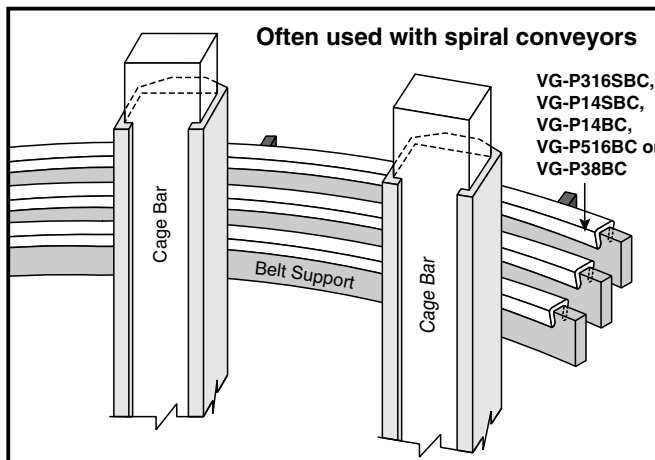

**SYSTEM
PLAST™**

©2015 Regal-Beloit Corporation, All Rights Reserved.

*Extruded profiles stored in coils will have the tendency to retain a certain deformation when uncoiled, therefore consistency in the profile cross section over the full length of the coil cannot be guaranteed.



5/16"



P516BC

Clips onto 5/16 flat bar. Can be used as a standard belt support.

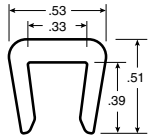

Material: UHMW

Part Number	Length (ft.)
VG-P516BC-10	10
VG-P516BC-20	20
VG-P516BC-100	100*
VG-P516BC-250	250*

10 mm



PM10BC

Clips onto 10 mm flat bar. Can be used as a standard belt support.

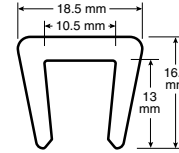

Material: UHMW

Part Number	Length (ft.)
VG-PM10BC-10	10
VG-PM10BC-20	20
VG-PM10BC-100	100*
VG-PM10BC-250	250*

3/8"



P38BC

Clips onto 3/8 flat bar. Can be used as a standard belt support.

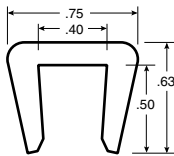

VG-P38BC-10	10
VG-P38BC-20	20
VG-P38BC-100	100*
VG-P38BC-250	250*

1/2"



P12BC

Clips onto 1/2 flat bar. Can be used as a standard belt support.

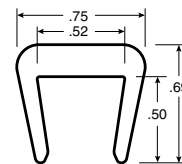

VG-P12BC-10	10
VG-P12BC-20	20
VG-P12BC-100	100*
VG-P12BC-250	250*

P38HD

Clips onto 3/8 flat bar. Can be used as an extra wide heavy duty belt support.

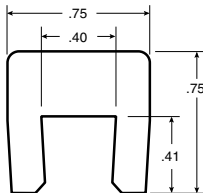

VG-P38HD-10	10
VG-P38HD-20	20

VG-P38BC

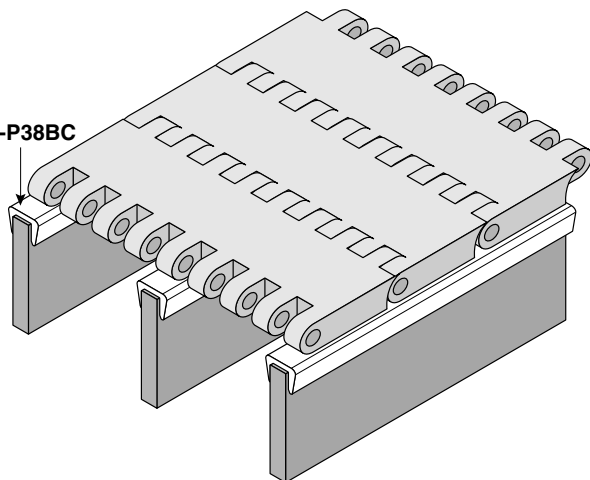

Shipping Information: UHMW covers and inserts are typically shipped straight in tubes. 8' lengths can be shipped UPS. Standard 10' or 20' lengths are shipped by common carrier. Selected items can be coiled into cartons for more convenient shipping.

Extended Coil Lengths: Items marked with this symbol are available in continuous lengths of 100' or more. These items must be coiled for shipping and handling.



*Extruded profiles stored in coils will have the tendency to retain a certain deformation when uncoiled, therefore consistency in the profile cross section over the full length of the coil cannot be guaranteed.

Neck Guides

Neck Guides for PET Containers

Helps guide PET containers in high speed, air conveying applications. Nolu-SR is a proprietary blend of UHMW and other USDA accepted lubricants, resulting in a harder, lower friction material that is ideal in these applications. Though designs differ, the material of choice is Nolu-SR, proven to increase throughput, reduce jams and wear longer.

*Extruded profiles stored in coils will have the tendency to retain a certain deformation when uncoiled, therefore consistency in the profile cross section over the full length of the coil cannot be guaranteed.

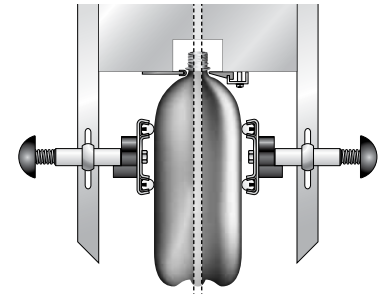

P105R

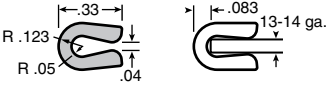

Neck Guide

Clips onto 13 ga. (.090) or 14 ga. (.073) sheet metal.



Material: Dark Grey Nolu-SX.

Part Number	Length (ft.)
VG-P105R-SX-100	100*
VG-P105R-SX-250	250*

P105F

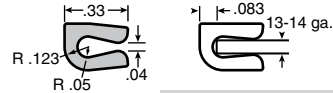

Neck Guide

Clips onto 13 ga. (.090) or 14 ga. (.073) sheet metal.



Material: Dark Grey Nolu-SX.

Part Number	Length (ft.)
VG-P105F-SX-100	100*
VG-P105F-SX-250	250*

NG47

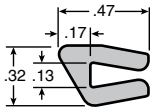

Neck Guide

Clips onto 11 ga. (.120) sheet metal.



Material: Dark Grey Nolu-SX.

Part Number	Length (ft.)
VG-NG47-SX-100	100*
VG-NG47-SX-250	250*

NG49



Neck Guide

Clips onto 13 ga. (.090) or 14 ga. (.073) sheet metal.



Material: Dark Grey Nolu-SX.

Part Number	Length (ft.)
VG-NG49-SX-100	100*
VG-NG49-SX-250	250*

NG50

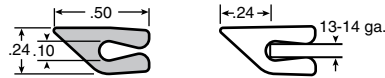

Neck Guide

Clips onto 13 ga. (.090) or 14 ga. (.073) sheet metal.



Material: Dark Grey Nolu-SX.

Part Number	Length (ft.)
VG-NG50-SX-100	100*
VG-NG50-SX-250	250*

NG51



Neck Guide

Clips onto 13 ga. (.090) or 14 ga. (.073) sheet metal.



Material: Dark Grey Nolu-SX.

Part Number	Length (ft.)
VG-NG51-SX-100	100*
VG-NG51-SX-250	250*

NG81

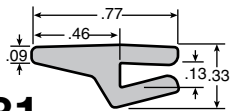

Neck Guide

Clips onto 11 ga. (.120) sheet metal.



Material: Dark Grey Nolu-SX.

Part Number	Length (ft.)
VG-NG81-SX-100	100*
VG-NG81-SX-250	250*

NG91

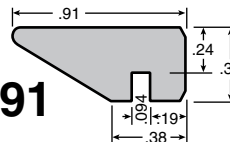

Neck Guide

Replacement for various European equipment manufacturers.

Material: Dark Grey Nolu-SX.

Part Number	Length (ft.)
VG-NG91-SX-10	10
VG-NG91-SX-20	20

Also available in curves. See below.

NG110

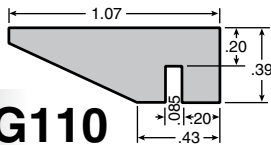

Neck Guide

Replacement for various European equipment manufacturers.

Material: Nolu-SR.

Part Number	Length (ft.)
VG-NG110-SR-10	10
VG-NG110-SR-20	20

Also available in curves. See below.

NG125

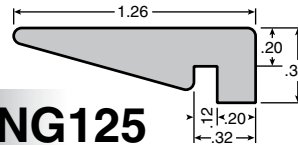

Neck Guide

Replacement for various European equipment manufacturers.

Material: Dark Grey Nolu-SX.

Part Number	Length (ft.)
VG-NG125-SX-10	10
VG-NG125-SX-20	20

Also available in curves. See below.

Neck Guide Curve (2 pieces)

Machined inside and outside curves. Replacement for various European equipment manufacturers. Other special order radii available.

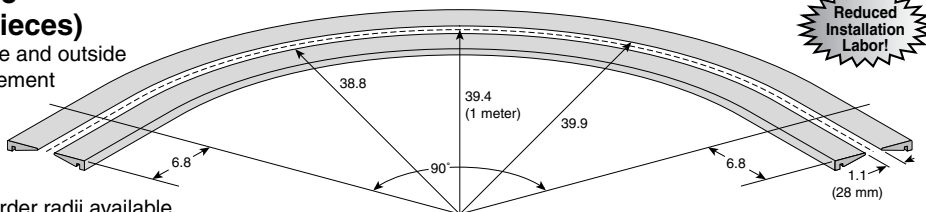

Material: Nolu-SR.

Part Number

VG-NG91-SR-1M28

VG-NG110-SR-1M28

VG-NG125-SR-1M28

Shown in drawing to the left.

UHMW Covers & Aluminum Rails



Bottle Guide

Aluminum guide rail with Nolu-S insert is used to guide containers, especially PET, in applications such as air conveying. Many air conveyor users and manufacturers have found that brush guides not only tend to get contaminated with debris, which causes increased friction and marking of PET bottles, but also the bristles can wear quickly and/or fall out. Nolu-S is the perfect combination of extremely low friction in a tough UHMW based material. Nolu-S will not mark bottles while allowing faster speeds and greater throughput.

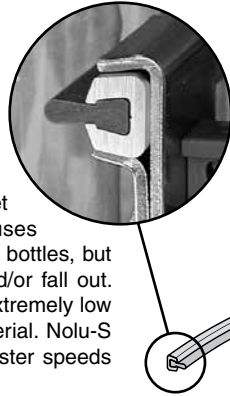

**Low friction,
non-marking!
More sanitary**

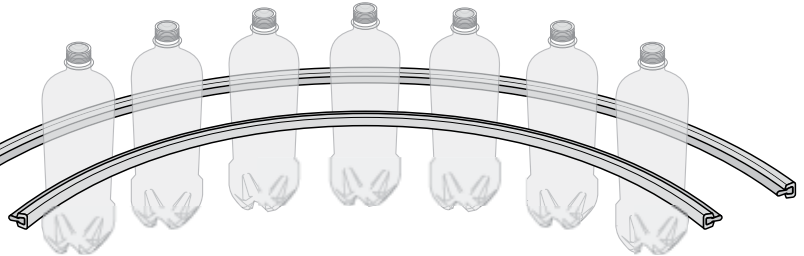
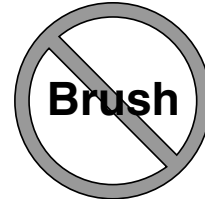

*Extruded profiles stored in coils will have the tendency to retain a certain deformation when uncoiled, therefore consistency in the profile cross section over the full length of the coil cannot be guaranteed.

ABG

Aluminum Rail

Accepts all VG-PBG inserts. Works with all standard Valu Guide rail clamps.

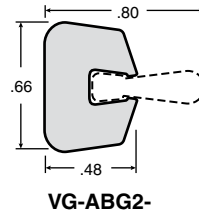
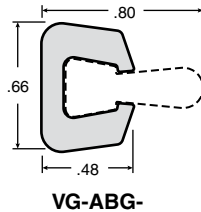
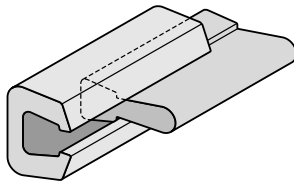

Material: Clear anodized aluminum

Part Number	Length (ft.)
VG-ABG-10	10
VG-ABG-20	20
VG-ABG2-10	10

UHMW Covers & Aluminum Rails

PBG

Nolu-S Insert

For use with VG-ABG aluminum rail. This guide is available in the ultra low friction Nolu-S.

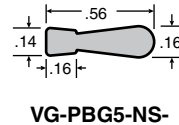

Material: Nolu-S

Part Number	Length (ft.)
VG-PBG5-NS-100	100*



Nolu-SD Insert

For use with VG-ABG aluminum rail. This guide is available in the ultra low friction Nolu-SD, which combines low friction qualities with a static dissipating ability.

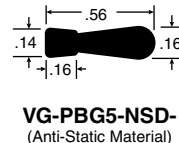
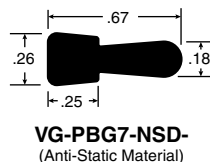

Material: Nolu-SD (Anti-static material)

Part Number	Length (ft.)
VG-PBG7-NSD-100	100*
VG-PBG5-NSD-100	100*



Nolu-SR neck guides and Nolu-S body guides, with an ultra low coefficient of friction, reduces the degree of bottle tilt and the corresponding wear problems.

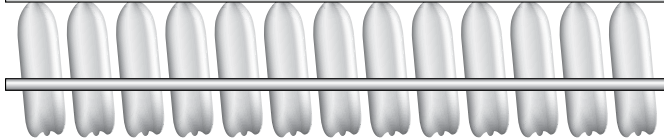

Other guides (especially brushes), when contaminated, can cause irregular tilt and orientation of the bottles, resulting in blockage at curves or inclines.

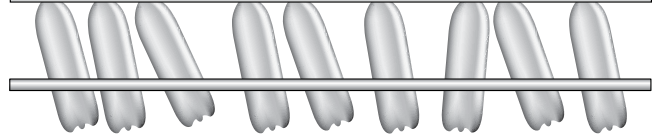

Field Bendable!

Easily bent on site using a portable Valu Guide rail bender. Bends to min. 30" radius with zero crimping of aluminum which allows for continuous feed of plastic thru straights and curves with minimal splicing.



See page 220 for Valu Guide rail bender details.

	For Inside Curve		For Outside Curve	
VG-ABG-				
VG-ABG2-				



J-Leg Profiles

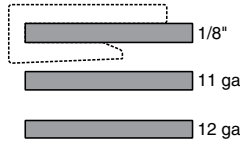
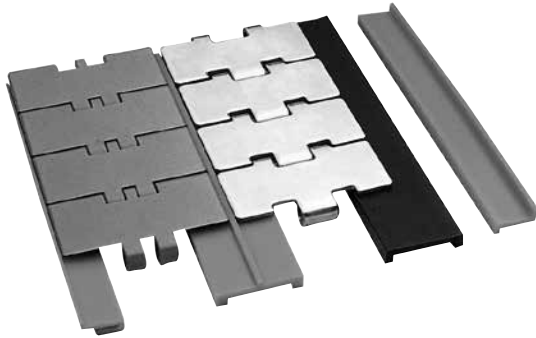

Superior chain interface and cleanliness make System Plast J-Legs the right choice for domestic or international uses. Our J-Legs are designed to hold tight onto 11 ga. or 12 ga. sheet metal or 1/8 bar.



UHMW's natural low friction properties can be increased even further through the use of special additives. Our Nolu-S is a blend of UHMW and food grade lubricants, meeting the needs of ultra low-friction applications.

3/4" J-Legs

UHMW Covers & Aluminum Rails

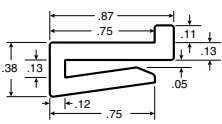

Material: UHMW-PE		
Part Number	Color	Length (ft.)
VG-JSL075-125-10	white	10
VG-JSL075-125-20	white	20

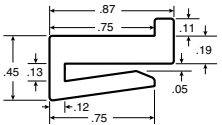

Material: UHMW-PE		
Part Number	Color	Length (ft.)
VG-JSL075-188-10	white	10
VG-JSL075-188-20	white	20

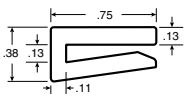

Material: UHMW-PE		
Part Number	Color	Length (ft.)
VG-P18CC-10	white	10
VG-P18CC-20	white	20

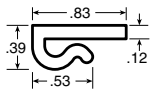

Material: UHMW-PE		
Part Number	Color	Length (ft.)
19003N	Black	200*
19003V	Green	200*



Material: Nolu-S UHMW-PE		
Part Number	Color	Length (ft.)
19003NS	Light Grey	200*

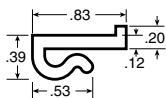

Material: UHMW-PE		
Part Number	Color	Length (ft.)
19007N	Black	200*
19007V	Green	200*



Material: Nolu-S UHMW-PE		
Part Number	Color	Length (ft.)
19007NS	Light Grey	200*

1" J-Legs

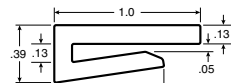

Material: UHMW-PE		
Part Number	Color	Length (ft.)
VG-JS100-125-10	white	10
VG-JS100-125-20	white	20
VG-JS100-125-100	white	100*
VG-JS100-125-250	white	250*

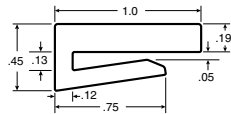

Material: UHMW-PE		
Part Number	Color	Length (ft.)
VG-JS100-188-10	white	10
VG-JS100-188-20	white	20

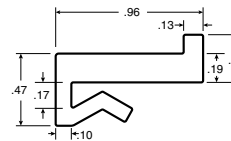

Material: UHMW-PE		
Part Number	Color	Length (ft.)
VG-JL081-188-10	white	10
VG-JL081-188-20	white	20

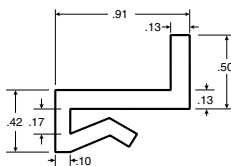

Material: UHMW-PE		
Part Number	Color	Length (ft.)
VG-JEL-078-125-10	white	10
VG-JEL-078-125-20	white	20

Options available for most wear strips:

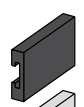
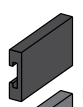
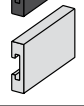
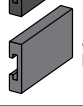
	Black UHMW: add "-B-" to part number		Static Dissipative UHMW: add "-SD-" to part number	Example: ↕ VG-P316HD-NS-10
	Nolu-S UHMW: (reduced friction) add "-NS-" to part number		Nolu-SR UHMW: add "-SR-" to part number	

*Extruded profiles stored in coils will have the tendency to retain a certain deformation when uncoiled, therefore consistency in the profile cross section over the full length of the coil cannot be guaranteed.

J-Leg Profiles



Shipping Information: Standard 10' or 20' UHMW covers and inserts are typically shipped by common carrier. Selected items can be coiled into cartons for more convenient shipping through UPS.

Our J-Legs are designed to hold tight onto 11 ga. or 12 ga. sheet metal or 1/8 bar.

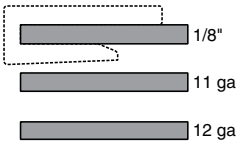

Extended Coil Lengths: Items marked with this symbol are available in continuous lengths of 100' or more. These items must be coiled for shipping and handling.



1" J-Legs (continued)

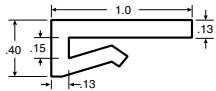

Part Number	Length (ft.)
VG-J100-125T-10	10
VG-J100-125T-20	20
VG-J100-125T-100	100*
VG-J100-125T-250	250*

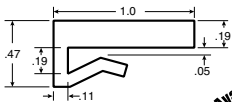

Part Number	Length (ft.)
VG-J100-188-10	10
VG-J100-188-20	20
VG-J100-188-100	100*

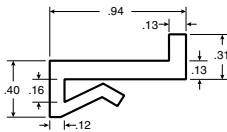

Part Number	Length (ft.)
VG-JEL081-125-10	10
VG-JEL081-125-20	20

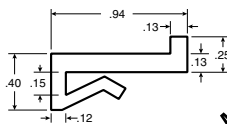

Part Number	Length (ft.)
VG-JL081-125-10	10
VG-JL081-125-20	20
VG-JL081-125-100	100*
VG-JL081-125-250	250*

1½" J-Legs

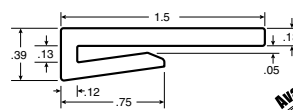

Part Number	Length (ft.)
VG-JS150-125-10	10
VG-JS150-125-20	20
VG-JS150-125-100	100*
VG-JS150-125-250	250*

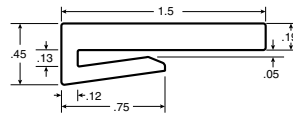

Part Number	Length (ft.)
VG-JS150-188-10	10
VG-JS150-188-20	20

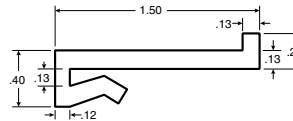

Part Number	Length (ft.)
VG-JL137-125-10	10
VG-JL137-125-20	20

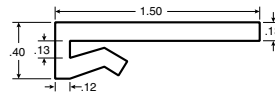

Part Number	Length (ft.)
VG-J150-125-10	10
VG-J150-125-20	20

UHMW Covers & Aluminum Rails

Options available for most wear strips:



Black UHMW:
add "B-" to
part number



Static Dissipative
UHMW:
add "SD-" to
part number



Nolu-S UHMW:
(reduced friction)
add "NS-" to
part number



Nolu-SR
UHMW:
add "SR-" to
part number

Example: VG-P316HD-NS-10

*Extruded profiles stored in coils will have the tendency to retain a certain deformation when uncoiled, therefore consistency in the profile cross section over the full length of the coil cannot be guaranteed.

**SYSTEM
PLAST™**



J-Leg Profiles

2" J-Legs

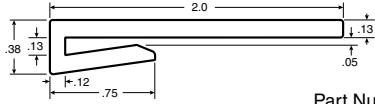

Part Number	Length (ft.)
VG-JS200-125-10	10
VG-JS200-125-20	20

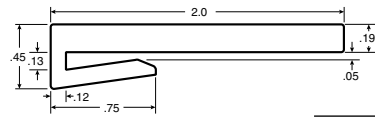

VG-JS200-188-10	10
VG-JS200-188-20	20

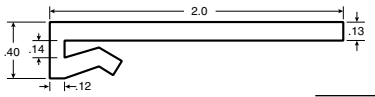

VG-J200-125-10	10
VG-J200-125-20	20

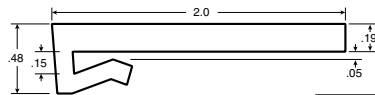

VG-J200-188-10	10
VG-J200-188-20	20

2 7/8" and 3" J-Legs

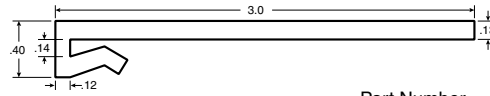

Part Number	Length (ft.)
VG-J300-125-10	10
VG-J300-125-20	20

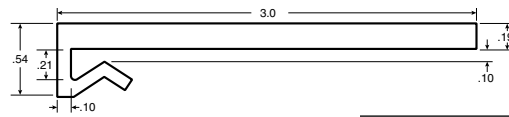

VG-J300-188-10	10
VG-J300-188-20	20

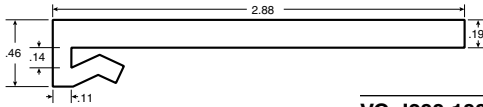

VG-J288-188-10	10
VG-J288-188-20	20

UHMW Covers & Aluminum Rails

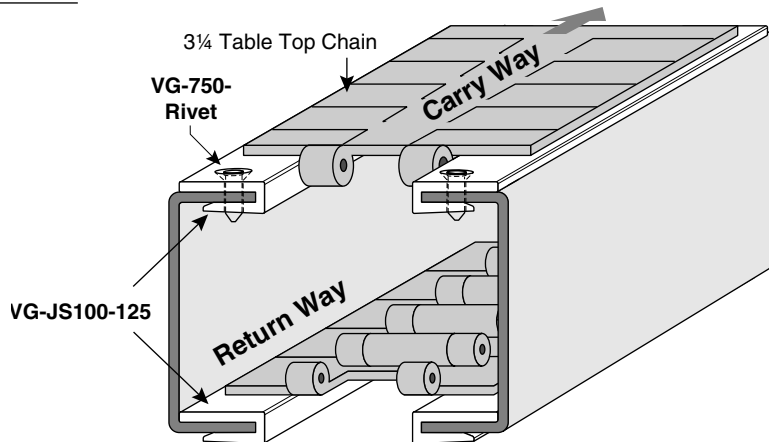



Additional J-Leg Profiles

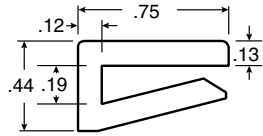

For use with 3/16" material



Part Number	Length
VG-JS3-075-125-10	10
VG-JS3-075-125-20	20
VG-JS3-075-125-100	100*
VG-JS3-075-125-250	250*

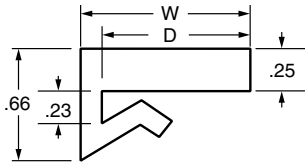

For use with 3/16" material

D dim.	W dim.	Part Number (10 ft.)	Part Number (20 ft.)
5/8	3/4	VG-J3-075-250-10	VG-J3-075-250-20
7/8	1	VG-J3-100-250-10	VG-J3-100-250-20
1-7/8	2	VG-J3-200-250-10	VG-J3-200-250-20

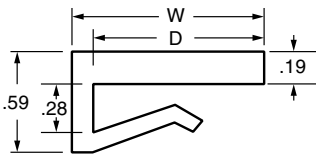

For use with 1/4" material

3/4	7/8	VG-J4-088-188-10	VG-J4-088-188-20
1	1-1/8	VG-J4-113-188-10	VG-J4-113-188-20
1-1/4	1-3/8	VG-J4-138-188-10	VG-J4-138-188-20
1-1/2	1-5/8	VG-J4-163-188-10	VG-J4-163-188-20
2	2-1/8	VG-J4-213-188-10	VG-J4-213-188-20

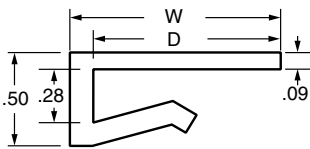

For use with 1/4" material

1	1-1/8	VG-J4-113-09-10	VG-J4-113-09-20
1-1/2	1-5/8	VG-J4-163-09-10	VG-J4-163-09-20
2	2-1/8	VG-J4-213-09-10	VG-J4-213-09-20

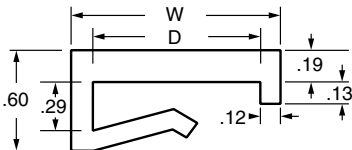

For use with 1/4" material

1	1-1/4	-	VG-JDL4-125-188-20
1-1/4	1-1/2	VG-JDL4-150-188-10	VG-JDL4-150-188-20
1-1/2	1-3/4	VG-JDL4-175-188-10	VG-JDL4-175-188-20
2	2-1/4	-	VG-JDL4-225-188-20

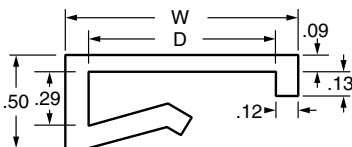

For use with 1/4" material

1	1-1/4	VG-JDL4-125-09-10	VG-JDL4-125-09-20
1-1/2	1-3/4	-	VG-JDL4-175-09-20
2	2-1/4	VG-JDL4-225-09-10	VG-JDL4-225-09-20

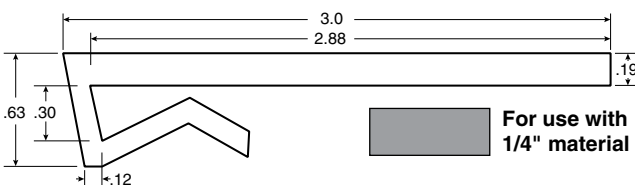

For use with 1/4" material

VG-J4-300-188-10	10
VG-J4-300-188-20	20

UHMW Covers & Aluminum Rails

*Extruded profiles stored in coils will have the tendency to retain a certain deformation when uncoiled, therefore consistency in the profile cross section over the full length of the coil cannot be guaranteed.



Wear Strip Profiles and Round Bar Covers

P417CT

Wear Strip Profiles

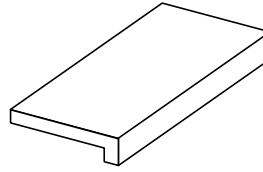
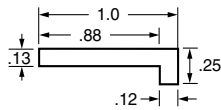

Material: UHMW

Part Number Length (ft.)

VG-P417CT-10 10

P7701

Wear Strip Profiles

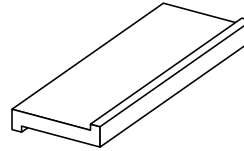
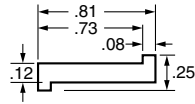

VG-P7701-10 10

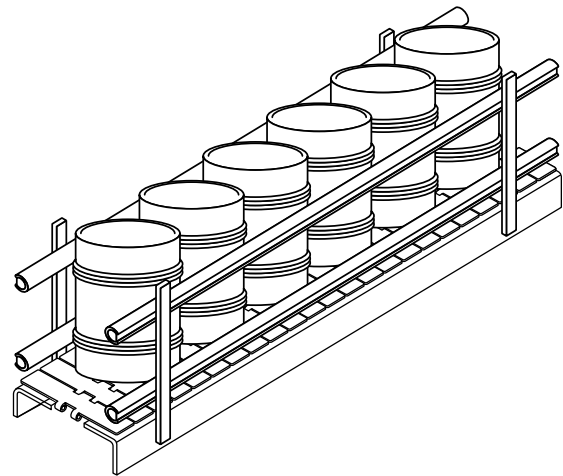
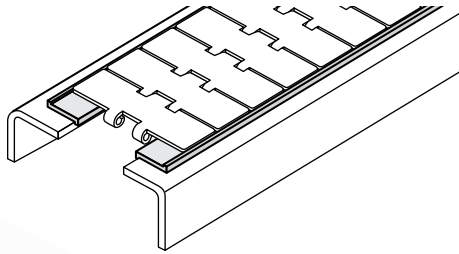

UHMW Covers & Aluminum Rails



These low friction, wear resistant UHMW covers are designed to fit around various diameters of round rod. Applications include conveyor side guides.

P516RD

5/16 full round side guide. Clips onto 5/16 diameter rod.

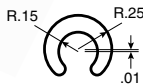

Material: UHMW

Part Number Length (ft.)

VG-P516RD-10 10

VG-P516RD-20 20

VG-P516RD-100 100*

VG-P516RD-250 250*

P12RD

1/2 full round side guide. Clips onto 1/2 diameter rod.

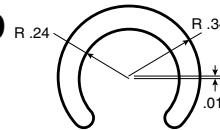

Material: UHMW

Part Number Length (ft.)

VG-P12RD-10 10

VG-P12RD-20 20

VG-P12RD-100 100*

VG-P12RD-250 250*

P38RD

3/8 full round side guide. Clips onto 3/8 diameter rod.

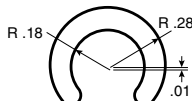

VG-P38RD-10 10

VG-P38RD-20 20

VG-P38RD-100 100*

VG-P38RD-250 250*

P58RD

5/8 full round side guide. Clips onto 5/8 diameter rod.

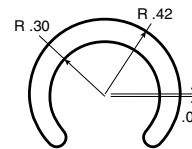

VG-P58RD-10 10

VG-P58RD-20 20

P34RD

3/4 full round side guide. Clips onto 3/4 diameter rod.

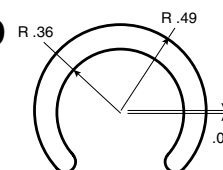

VG-P34RD-10 10

VG-P34RD-20 20

Shipping Information: UHMW covers and inserts are typically shipped straight in tubes. 8' lengths can be shipped UPS. Standard 10' or 20' lengths are shipped by common carrier. Selected items can be coiled into cartons for more convenient shipping.

Extended Coil Lengths: Items marked with this symbol are available in lengths of 100' or more. These items must be coiled for shipping and handling.



*Extruded profiles stored in coils will have the tendency to retain a certain deformation when uncoiled, therefore consistency in the profile cross section over the full length of the coil cannot be guaranteed.

SYSTEM PLAST™

©2015 Regal-Beloit Corporation, All Rights Reserved.

Half Round Bars and Covers



These low friction, wear resistant UHMW covers are designed to fit around various diameters of half round rod. Applications include conveyor side guides.

P12HR

1/2 half round side guide. Clips onto 1/2 diameter half round rod.

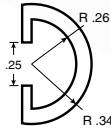

Material: UHMW

Part Number	Length (ft.)
VG-P12HR-10	10
VG-P12HR-20	20

P34HR

3/4 half round side guide. Clips onto 3/4 diameter half round rod.

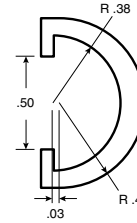

Material: UHMW

Part Number	Length (ft.)
VG-P34HR-10	10
VG-P34HR-20	20
VG-P34HR-100	100*
VG-P34HR-250	250*



P58HR

5/8 half round side guide. Clips onto 5/8 diameter half round rod.

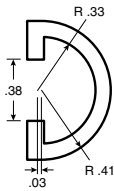

Part Number	Length (ft.)
VG-P58HR-10	10
VG-P58HR-20	20
VG-P58HR-100	100*
VG-P58HR-250	250*

P34HRL

3/4 half round side guide with leg. Clips onto 3/4 diameter half round rod.

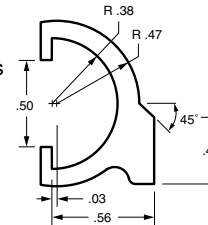

Part Number	Length (ft.)
VG-P34HRL-10	10
VG-P34HRL-20	20

*Extruded profiles stored in coils will have the tendency to retain a certain deformation when uncoiled, therefore consistency in the profile cross section over the full length of the coil cannot be guaranteed.



S12HR

1/2 half round rod.

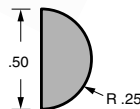

Material: Stainless steel

Part Number	Length (ft.)
VG-S12HR-10	10
VG-S12HR-20	20

S58HR

5/8 half round rod.

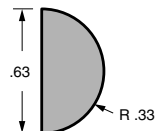

Part Number	Length (ft.)
VG-S58HR-10	10
VG-S58HR-20	20

S34HR

3/4 half round rod.

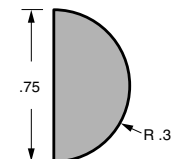

Material: Stainless steel

Part Number	Length (ft.)
VG-S34HR-10	10
VG-S34HR-20	20

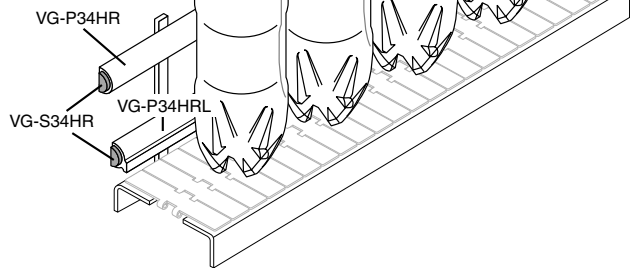

UHMW Covers & Aluminum Rails



Tube Covers

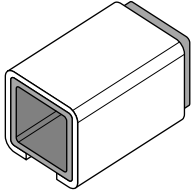

These low friction, wear resistant UHMW covers are designed to fit around various sizes of tubing or bar. Applications include spiral conveyor vertical member wear strips.

Also see page 244

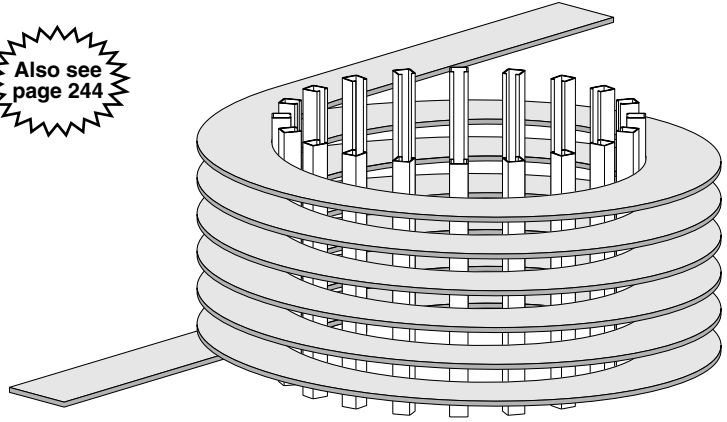

UHMW Covers & Aluminum Rails

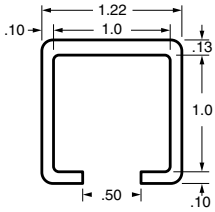

P1x1BC

1 x 1 tube cover.

Material: UHMW

Part Number	Length (ft.)
VG-P1x1BC-10	10
VG-P1x1BC-20	20

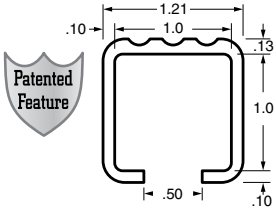

P1010RBC

1 x 1 ribbed tube cover.

VG-P1010RBC-20	20
----------------	----

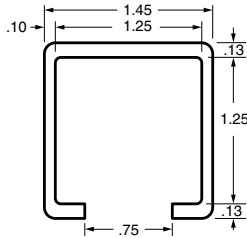

P125125BC

1-1/4 x 1-1/4 tube cover.

VG-P125125BC-10	10
VG-P125125BC-20	20

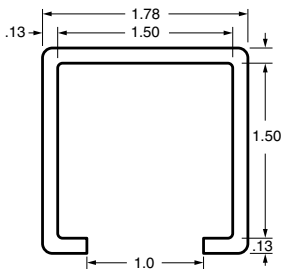

P1515BC

1-1/2 x 1-1/2 tube cover.

VG-P1515BC-10	10
VG-P1515BC-20	20

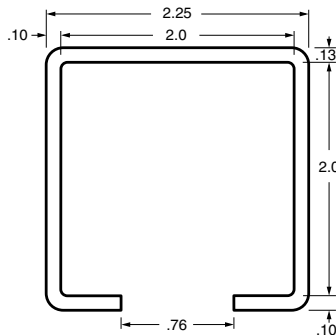

P2x2BC

2 x 2 tube cover.

VG-P2x2BC-10	10
VG-P2x2BC-20	20

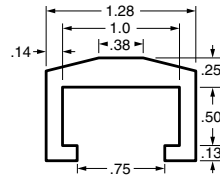

P5010BC

1/2 x 1 bar cover.

Material: UHMW

Part Number	Length (ft.)
VG-P5010BC-10	10
VG-P5010BC-20	20

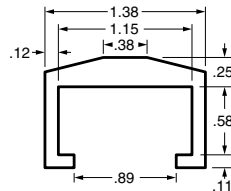

P58115BC

9/16 x 1-1/8 bar cover.

VG-P58115BC-20	20
----------------	----

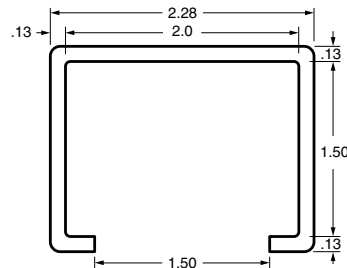

P1520BC

1-1/2 x 2 tube cover.

VG-P1520BC-20	20
---------------	----

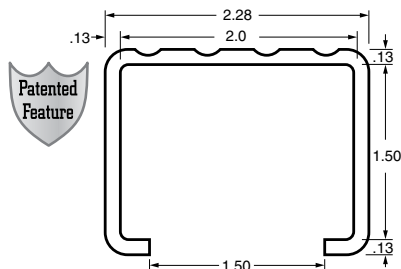

P1520RBC

1-1/2 x 2 ribbed tube cover.

VG-P1520RBC-10	10
VG-P1520RBC-20	20

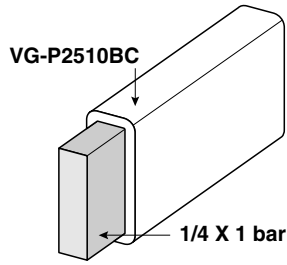

P2515BCB

Barbed belt support. For use with 1/4 x 1-1/2 bar.

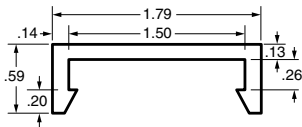

Material: UHMW

Part Number	Length (ft.)
VG-P2515BCB-10	10
VG-P2515BCB-20	20

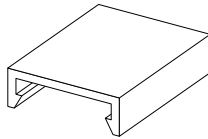

P2515DBC

Table top chain track. For use with 1/4 x 1-1/2 bar.

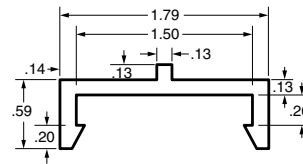

Material: UHMW

Part Number	Length (ft.)
VG-P2515DBC-20	20

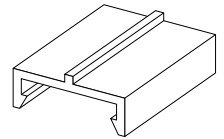

UHMW Covers & Aluminum Rails

P2510BC

UHMW cover. For use with 1/4 x 1 bar.

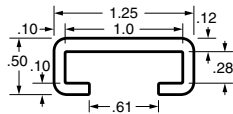

VG-P2510BC-10	10
VG-P2510BC-20	20

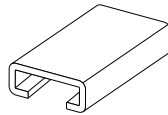

P1878BC

Side guide. For use with 1/8 x 7/8 bar.

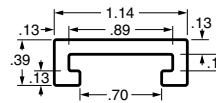

VG-P1878BC-10	10
VG-P1878BC-20	20

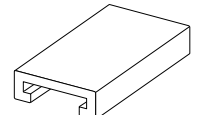

P1910BC

Side guide. For use with 3/16 x 1 bar.

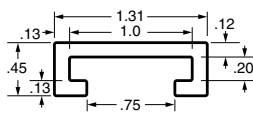

VG-P1910BC-10	10
VG-P1910BC-20	20

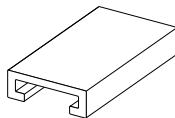

P2510NBC

Side guide. For use with 1/4 x 1 bar.

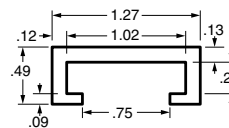

VG-P2510NBC-10	10
VG-P2510NBC-20	20

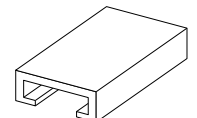

Options available for most wear strips:



Black UHMW:
add "-B-" to
part number



Static Dissipative
UHMW:
add "-SD-" to
part number



Nolu-S UHMW:
(reduced friction)
add "-NS-" to
part number



Nolu-SR
UHMW:
add "-SR-" to
part number

Example: VG-P316HD-NS-10



Bar Covers

P2515BC

Belt support. For use with 1/4 x 1-1/2 bar.

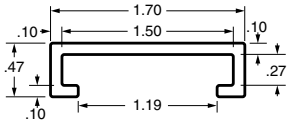

Material: UHMW

Part Number	Length (ft.)
VG-P2515BC-10	10
VG-P2515BC-20	20

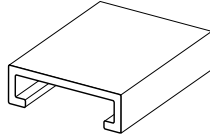

P2115BC

Side guide. For use with 3/16 x 1-1/2 bar.

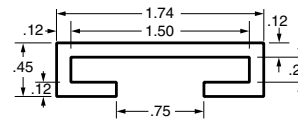

Material: UHMW

Part Number	Length (ft.)
VG-P2115BC-10	10

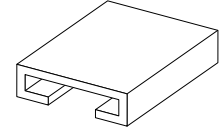

P2520BC

Side Guide. For use with 1/4 x 2 bar.

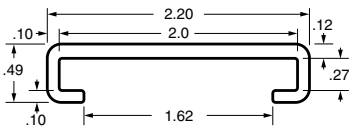

VG-P2520BC-10	10
VG-P2520BC-20	20

Also part of combination rails found on page 259.

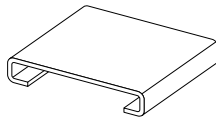

P3920BC

Side Guide. For use with 3/8 x 2 bar.

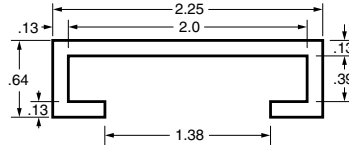

VG-P3920BC-10	10
VG-P3920BC-20	20

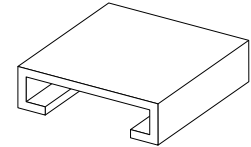

P2520NBC

Belt support. For use with 1/4 x 2 bar.

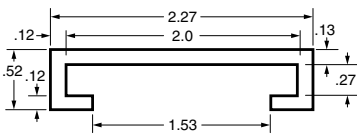

VG-P2520NBC-10	10
VG-P2520NBC-20	20

Also part of combination rails found on page 259.

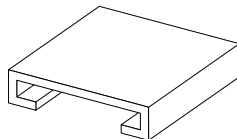

P5015BC

Side guide. For use with 1/2 x 1-1/2 bar.

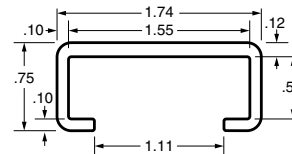

VG-P5015BC-10	10
VG-P5015BC-20	20

Also shown on page 260-261.

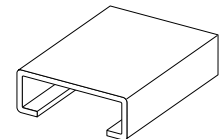

P5020BC

Side guide. For use with 1/2 x 2 bar.

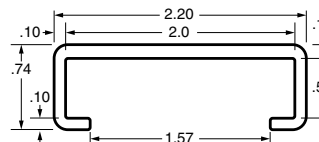

VG-P5020BC-10	10
VG-P5020BC-20	20

Also shown on page 260.

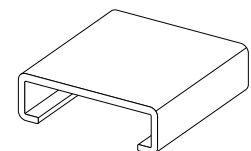

Combination Aluminum and UHMW Guide Rails



System Plast has designed aluminum extrusions which are now commonly used as side guide rails and as support members under belting and tabletop chain. The wear resistant inserts are made from UHMW materials. There are a number of interchangeable combinations for use in a variety of packaging machine and conveying applications. The aluminum rails are rugged, easily mounted structural members and the plastic inserts protect the package being conveyed from any metal contact and create a low friction, non-marring surface to guide and support the product.

Shipping Information: UHMW covers and inserts are typically shipped straight in tubes. 8' lengths can be shipped UPS. Standard 10' or 20' lengths are shipped by common carrier. Selected items can be coiled into cartons for more convenient shipping.

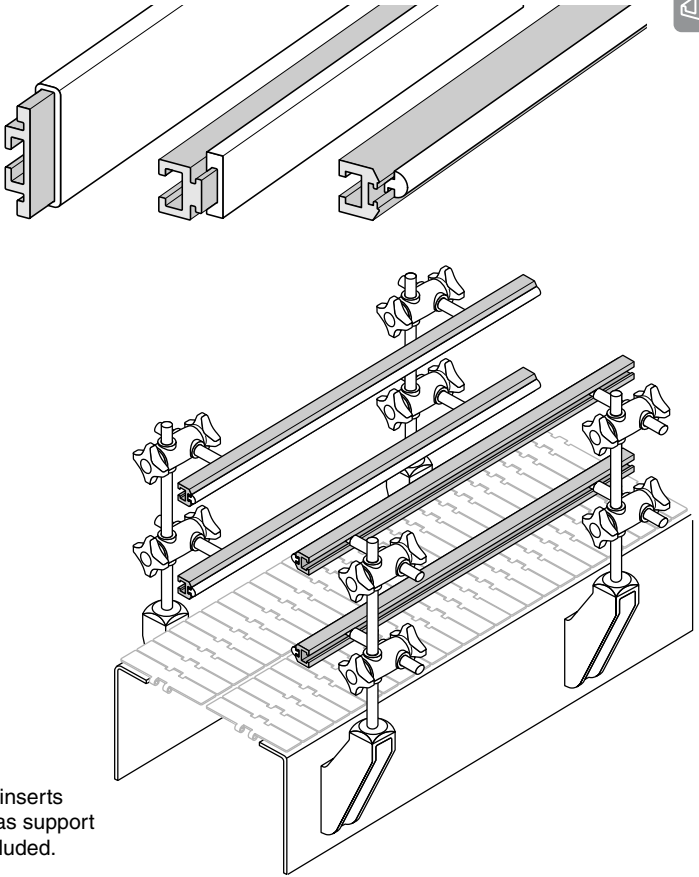

Combination Group A

The following aluminum extrusions can be used with any of the UHMW inserts listed in this group. These rails are commonly used as side guides and as support members under belting and table top chain. Fastening hardware not included.

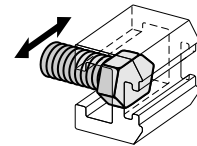
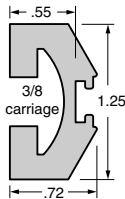
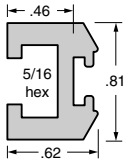

Material: Aluminum

		Length (ft.)
VG-A500-10	VG-A1000-10	10
VG-A500-20	VG-A1000-20	20

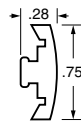

Material: UHMW

		Length (ft.)
VG-P2007-10	VG-P512-10	10
VG-P2007-20	VG-P512-20	20

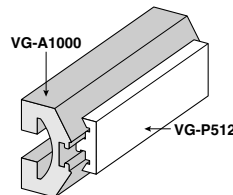
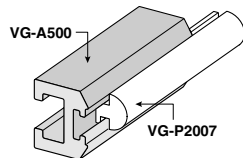

**SYSTEM
PLAST™**



Combination Aluminum and UHMW Guide Rails

Combination Group B

The following aluminum extrusions can be used with any of the UHMW inserts listed in this group. These rails are commonly used as side guides and as support members under belting and table top chain. Fastening hardware not included.

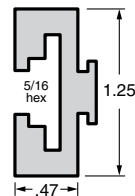
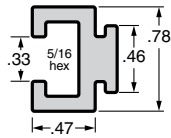
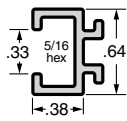
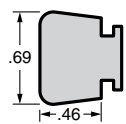
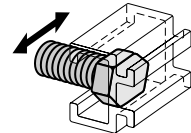

Material: Aluminum

Length (ft.)

		VG-A600-8		8
VG-A275-10	VG-A225-10	VG-A600-10	VG-A900-10	10
VG-A275-20	VG-A225-20	VG-A600-20	VG-A900-20	20

UHMW Covers & Aluminum Rails

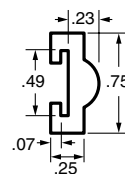
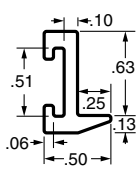
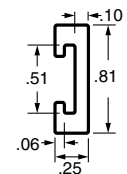
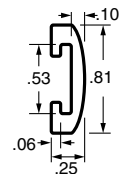

Material: UHMW

Length (ft.)

VG-P813-10	VG-P813F-10	VG-P0808-10	VG-P611-10	10
VG-P813-20	VG-P813F-20	VG-P0808-20		20
VG-P813-100	VG-P813F-100			100

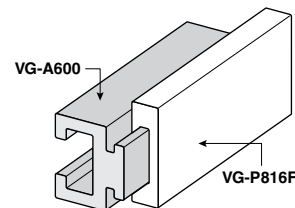
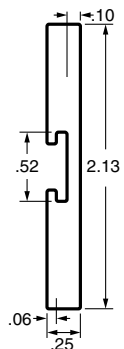
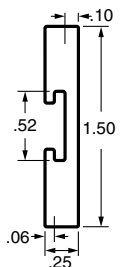
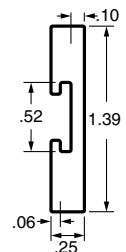
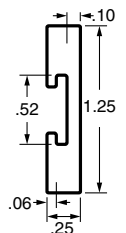
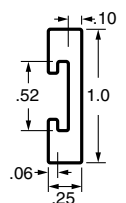

Material: UHMW

Length (ft.)

VG-P816F-10	VG-P820F-10	VG-P822F-10	VG-P824F-10	VG-P834F-10	10
VG-P816F-20	VG-P820F-20	VG-P822F-20	VG-P824F-20	VG-P834F-20	20

Options available for most wear strips:

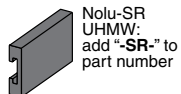
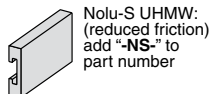

Example: **VG-P316HD-NS-10**

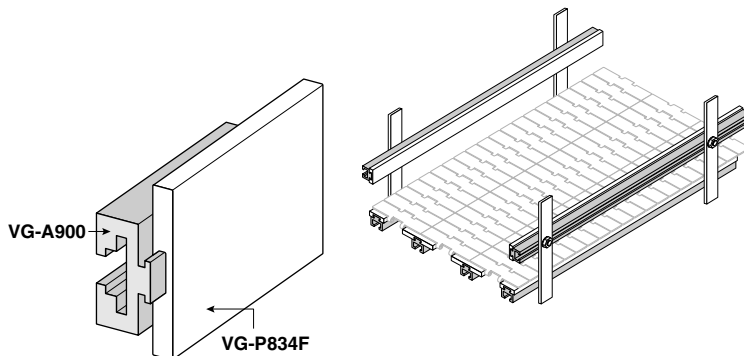



Combination Group C

The following aluminum extrusions can be used with any of the UHMW inserts listed in this group. These rails are commonly used as side guides and as support members under belting and table top chain. The aluminum rail fastens with a 1/4 hex head bolt (not included).

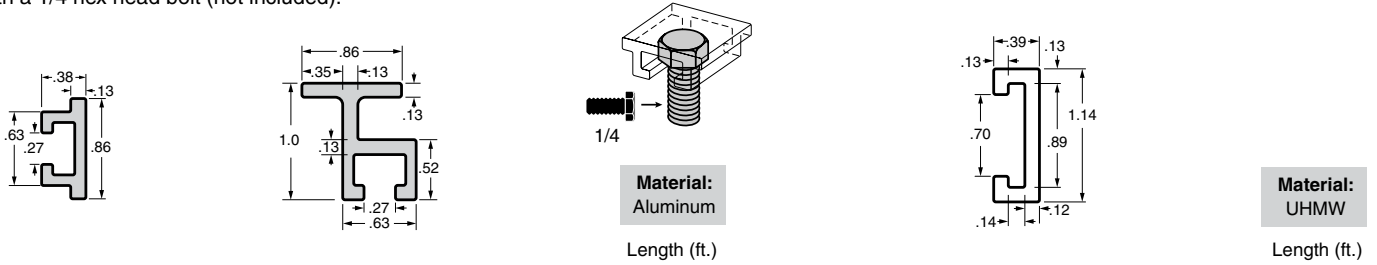

VG-A1878-10	-	10	VG-P1878BC-10	10
VG-A1878-20	VG-A1878T-20	20	VG-P1878BC-20	20

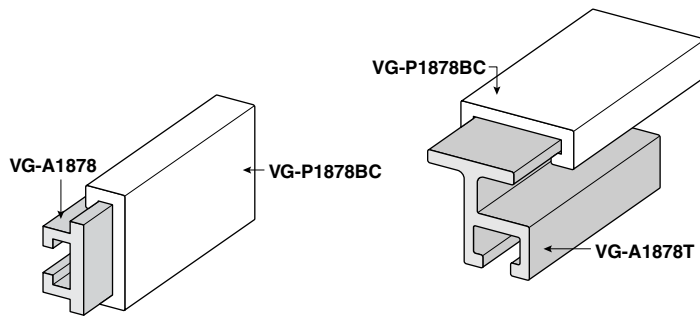

Options available for most wear strips:

- Nolu-S UHMW: (reduced friction) add "-NS-" to part number
- Static Dissipative UHMW: add "-SD-" to part number
- Nolu-SR UHMW: add "-SR-" to part number

Example: \downarrow
VG-P316HD-NS-10

UHMW Covers & Aluminum Rails

Combination Group D

The following aluminum extrusions can be used with any of the UHMW inserts listed in this group. These rails are commonly used as side guides and as support members under belting and table top chain. The aluminum rail fastens with a 5/16 carriage head bolt (not included).

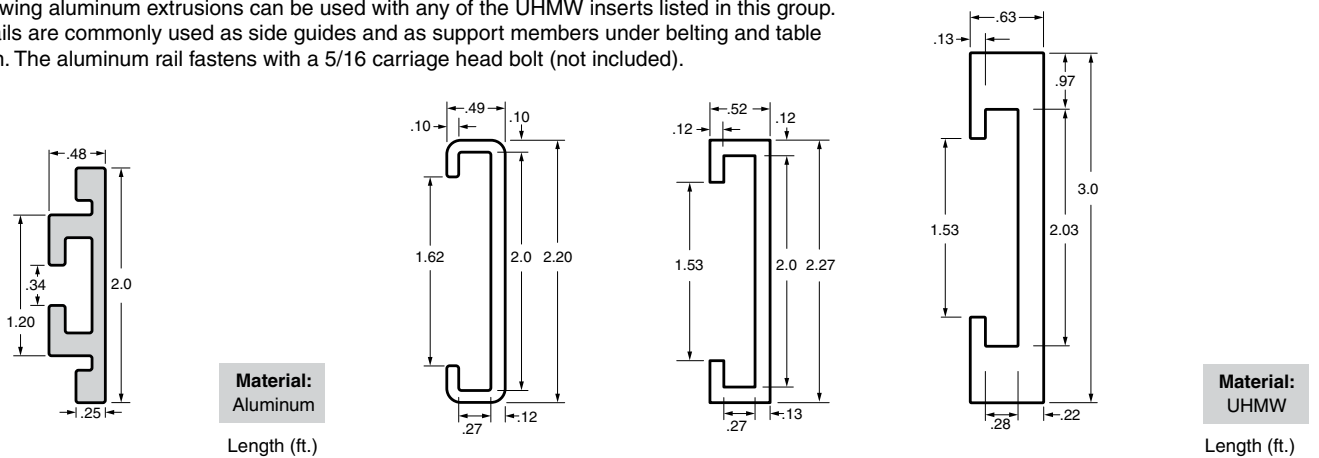

VG-A2520-10	10	VG-P2520BC-10	VG-P2520NBC-10	VG-P2520WBC-10	10
VG-A2520-20	20	VG-P2520BC-20	VG-P2520NBC-20		20

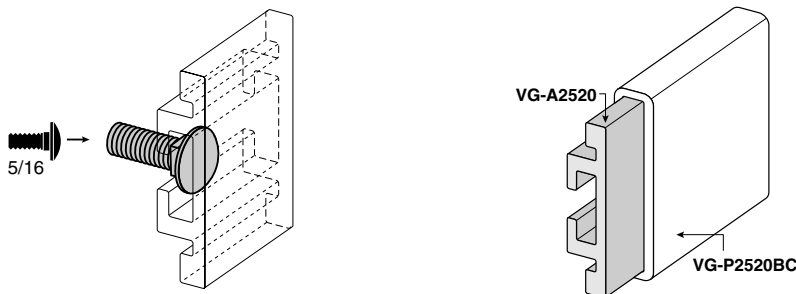



Aluminum and UHMW Guide Rails

A5015

Aluminum Guide Rail

Aluminum extrusions commonly used as side guide rails and as support members under belting and table top chain. Fastens with 5/16 carriage bolt (not included).

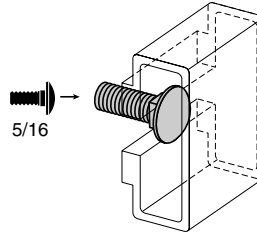
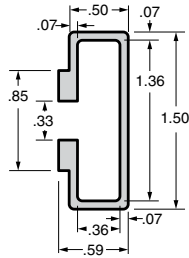

Material: Aluminum

Part Number	Length (ft.)
VG-A5015-10	10
VG-A5015-20	20

P5015BC

UHMW Cover

Low friction, wear resistant UHMW cover designed to be used with VG-A5015.

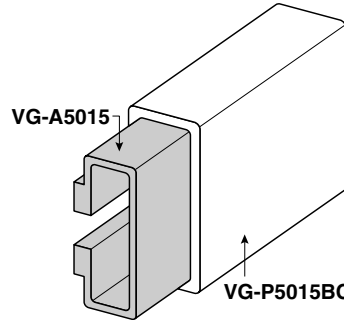
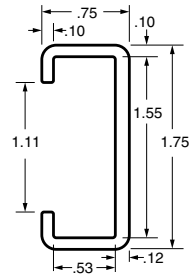

Material: UHMW

Part Number	Length (ft.)
VG-P5015BC-10	10
VG-P5015BC-20	20

Also shown on page 261.

UHMW Covers & Aluminum Rails

A5020

Aluminum Rail

Accepts VG-P5020BC UHMW cover. Fastens with 3/8 carriage bolt (not included).

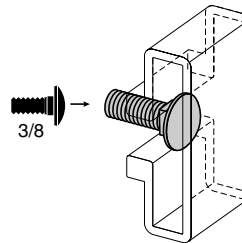
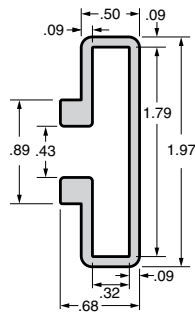

Material: Aluminum

Part Number	Length (ft.)
VG-A5020-10	10
VG-A5020-20	20

P5020BC

UHMW Cover

For use with VG-A5020 rail.

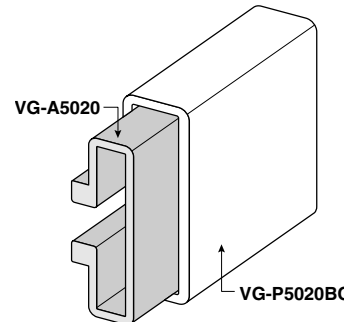
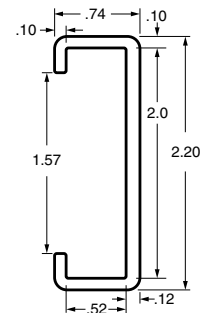

Material: UHMW

Part Number	Length (ft.)
VG-P5020BC-10	10
VG-P5020BC-20	20



5015

Steel Rail

Galvanized (G5015) or stainless steel (S5015). Accepts VG-P5015BC UHMW cover. Fastens with 3/8 carriage head bolt (not included).

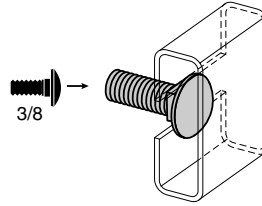
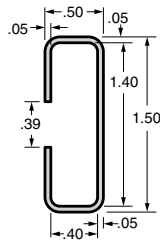

Material: Galvanized (G) or stainless steel (S).

Part Number	Length (ft.)
VG-G5015-10	10
VG-G5015-20	20
VG-S5015-10	10
VG-S5015-20	20

P5015BC

UHMW Cover

For use with VG-G5015 or VG-S5015 rail or any 1/2 x 1-1/2 bar.

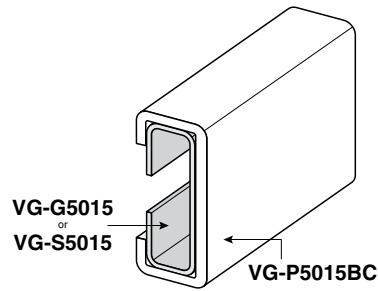
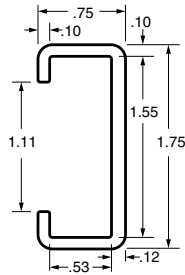

Material: UHMW

Part Number	Length (ft.)
VG-P5015BC-10	10
VG-P5015BC-20	20

UHMW Covers & Aluminum Rails



P38

3/8 UHMW Round Bar
Can be used with VG-021-03.

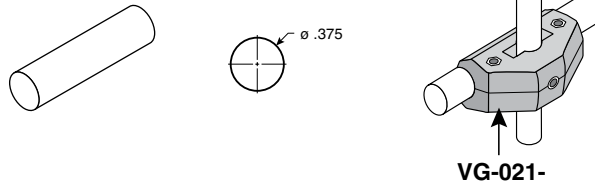

Material: UHMW

Part Number	Dia.	Length (ft.)
VG-P38RDBAR-10	3/8	10
VG-P38RDBAR-20	3/8	20

P12

1/2 UHMW Round Bar
Can be used with VG-032-12-, VG-021-02 or VG-019-12.

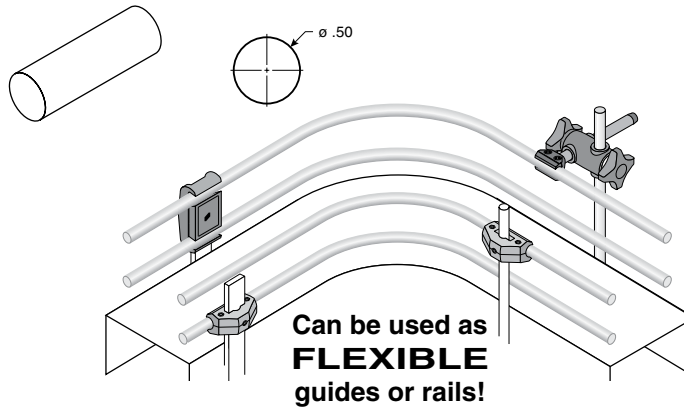

Material: UHMW

Part Number	Dia.	Length (ft.)
VG-P12RDBAR-10	1/2	10
VG-P12RDBAR-20	1/2	20

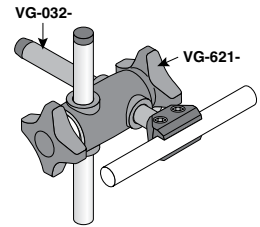

See pages 236-237 for more information, including 1/2" stainless steel rod.

UHMW Covers & Aluminum Rails

Round Bars

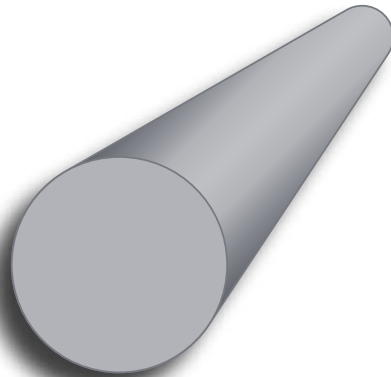

Material: Nolu-S (grey)

Part Number	Dia.	Length (ft.)
012R10A-5	5/8	5
012R10A-10	5/8	10
012R16A-5	1	5
012R16A-10	1	10
012R20A-5	1-1/4	5
012R20A-10	1-1/4	10
012R24A-5	1-1/2	5
012R24A-10	1-1/2	10
012R32A-5	2	5
012R32A-10	2	10
012R40A-5	2-1/2	5
012R40A-10	2-1/2	10
012R48A-5	3	5
012R48A-10	3	10

On request and for adequate quantities these bars can be produced with different lengths.



Flight Edging

Made from low friction, low wear, corrosive resistant UHMW, flight edging is a proven value that can extend the life of new screws and salvage existing ones with worn edges. It has also proven beneficial on inclined conveyors by safely reducing the clearance between screw and trough, helping to minimize fall-back of smaller particles.

Flight edging is simply installed by winding the material around the shaft between the flights, then starting at one end, progressively tapping the extrusion onto the edge of the flight with a block or hammer. A fastener is required at the leading edge to hold flight edging in place.

All flight edging is UV stabilized to reduce the effects of ultraviolet radiation. This will significantly improve the life of the profile when exposed to direct sunlight, yet will not degrade any of the other desirable properties of the UHMW.

Improve clean-out of troughs

UV stabilized for outdoor use

Reduce fall-back on inclined screws

Eliminate hangers on shorter screws

Use with helicoid or sectional flights

Quick installation and replacement

Reduce noise and wear

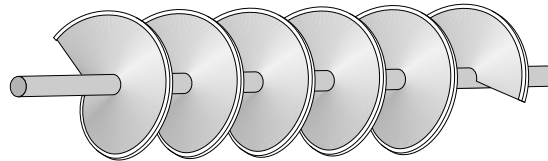
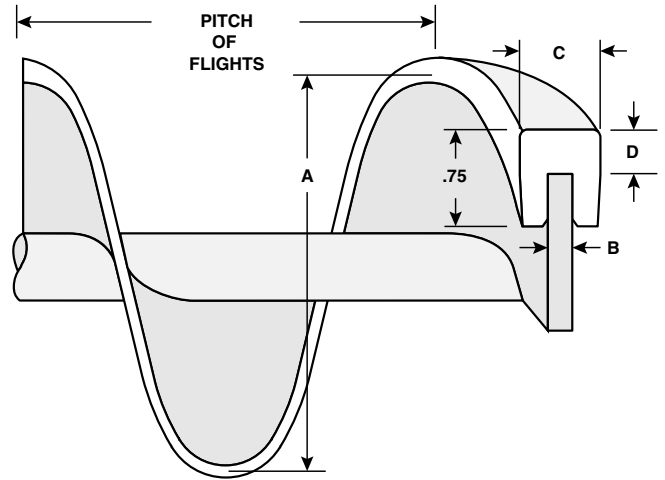

UHMW Covers & Aluminum Rails

To determine approximate amount of edging required (in feet), use the following formulas:

For Full Pitch Screws:
Length of conveyor section in feet x 3.4

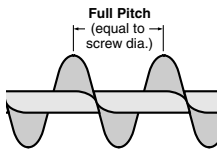

For Half Pitch Screws:
Length of conveyor section in feet x 6.7

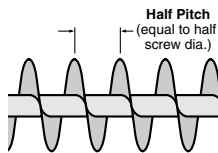

For Irregular Pitch Screws:
Number of pitches x dia. (in inches) x .283

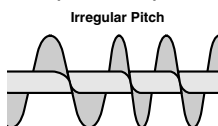

Material: UHMW-PE Natural

Part Number (50 ft.)	Part Number (100 ft.)	A Screw Dia. (in.)	B Flight Thickness	C Profile Width	D Profile Thickness
SCX-6-1/16-50	SCX-6-1/16-100	6	1/16 (.063)	.437	.350
SCX-6-1/8-50	SCX-6-1/8-100	6	1/8 (.125)	.437	.350
SCX-6-3/16-50	SCX-6-3/16-100	6	.134	.437	.350
SCY-6-3/16-50	SCY-6-3/16-100	6	3/16 (.188)	.625	.350
SCX-9-1/4-50	SCX-9-1/4-100	9	1/4 (.250)	.625	.350
SCX-9-3/8-50	SCX-9-3/8-100	9	3/8 (.375)	.625	.350
SCX-9-1/2-50	SCX-9-1/2-100	9	1/2 (.500)	.625	.350
SCY-9-1/4-50	SCY-9-1/4-100	9	1/4 (.250)	.625	.350
SCY-9-3/8-50	SCY-9-3/8-100	9	3/8 (.375)	.625	.350
SCY-9-1/2-50	SCY-9-1/2-100	9	1/2 (.500)	.625	.350
SCX-12-1/4-50	SCX-12-1/4-100	12	1/4 (.250)	.625	.350
SCX-12-3/8-50	SCX-12-3/8-100	12	3/8 (.375)	.625	.350
SCX-12-1/2-50	SCX-12-1/2-100	12	1/2 (.500)	.625	.350
SCY-12-1/4-50	SCY-12-1/4-100	12	1/4 (.250)	.625	.350
SCY-12-3/8-50	SCY-12-3/8-100	12	3/8 (.375)	.625	.350
SCY-12-1/2-50	SCY-12-1/2-100	12	1/2 (.500)	.625	.350
SCX-16-1/4-50	SCX-16-1/4-100	16	1/4 (.250)	.625	.350
SCX-16-3/8-50	SCX-16-3/8-100	16	3/8 (.375)	.625	.350
SCX-16-1/2-50	SCX-16-1/2-100	16	1/2 (.500)	.625	.350
SCY-16-1/4-50	SCY-16-1/4-100	16	1/4 (.250)	.625	.350
SCY-16-3/8-50	SCY-16-3/8-100	16	3/8 (.375)	.625	.350
SCY-16-1/2-50	SCY-16-1/2-100	16	1/2 (.500)	.625	.350
SCY-20-1/4-50	SCY-20-1/4-100	20	1/4 (.250)	.625	.350
SCY-24-1/4-50	SCY-24-1/4-100	24	1/4 (.250)	.625	.350
SCY-24-3/8-50	SCY-24-3/8-100	24	3/8 (.375)	.625	.350

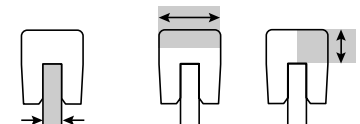



Screw Conveyor Hanger Bearings

Hanger Bearings

Screw Conveyor Hanger Bearings are designed to support the center shaft of a feed screw, and are exposed to all media or products being conveyed. The bearing material used for screw conveyors must be carefully selected in order to withstand the environmental conditions and the presence of abrasive materials.

In some applications, material selection is further limited by the need to comply with FDA and/or USDA specifications for food handling, which often rule out metallic bearing materials. Nonmetallic materials for screw conveyor hanger bearings are available from System Plast. Both UHMW and Nolu-S are proven in numerous applications.

UHMW Covers & Aluminum Rails

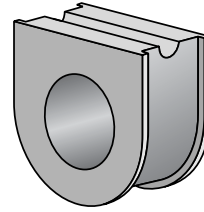
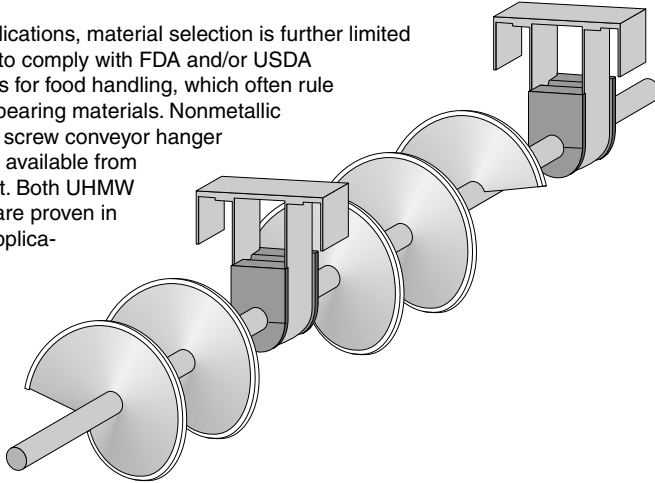

Nolu-S

Nolu-S is a proprietary alloy of food grade lubricants combined with UHMW. This creates a material which retains most of the properties of UHMW while significantly reducing friction. Nolu-S advantages include protection of expensive mating surfaces, lower noise levels and FDA and USDA approved ingredients.

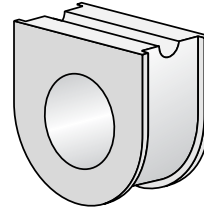

UHMW

H series hanger bearings are manufactured from UHMW, the most abrasion resistant, low friction thermoplastic created. This material complies with FDA and USDA specifications for direct food contact applications. Impact loads will not crack these even at low temperature.

HAC

Hanger Bearing

Hanger styles:
20B-26B-28B-
220-226-326

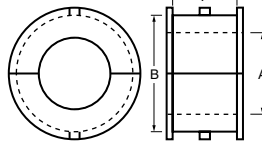
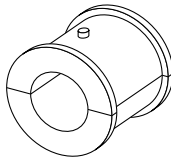



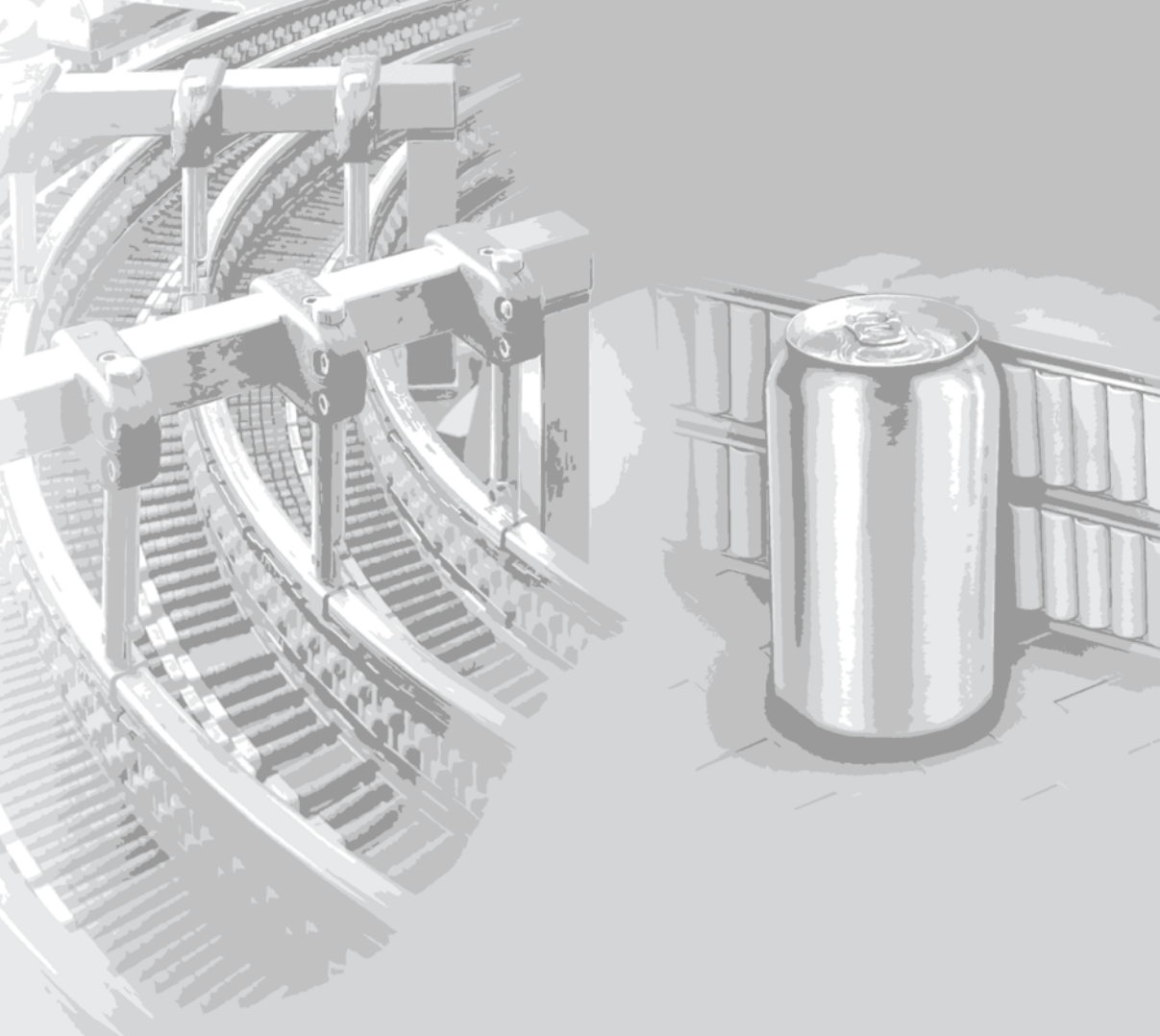

UHMW	Nolu-S	A	B	C
HAC-3244	SAC-3244	2	2-3/4	1-9/16
HAC-4864	-	3	4	2-3/8
HAC-5576	-	3-7/16	4-3/4	3-1/8



BEAD AND ROLLER GUIDES

Section 5

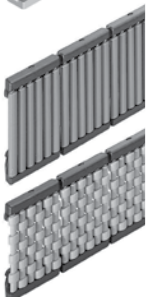
- 
SpeedRail SB
 ... Page **269**
- 
Flexible SpeedRail & SpeedRoll ...
 Page **271**
- 
SpeedRoll ...
 Page **272**
- 
SpeedRail ...
 Page **274**
- 
BeadRail ...
 Page **275**
- 
Flexible Bead & Roller Guides...
 Page **276**

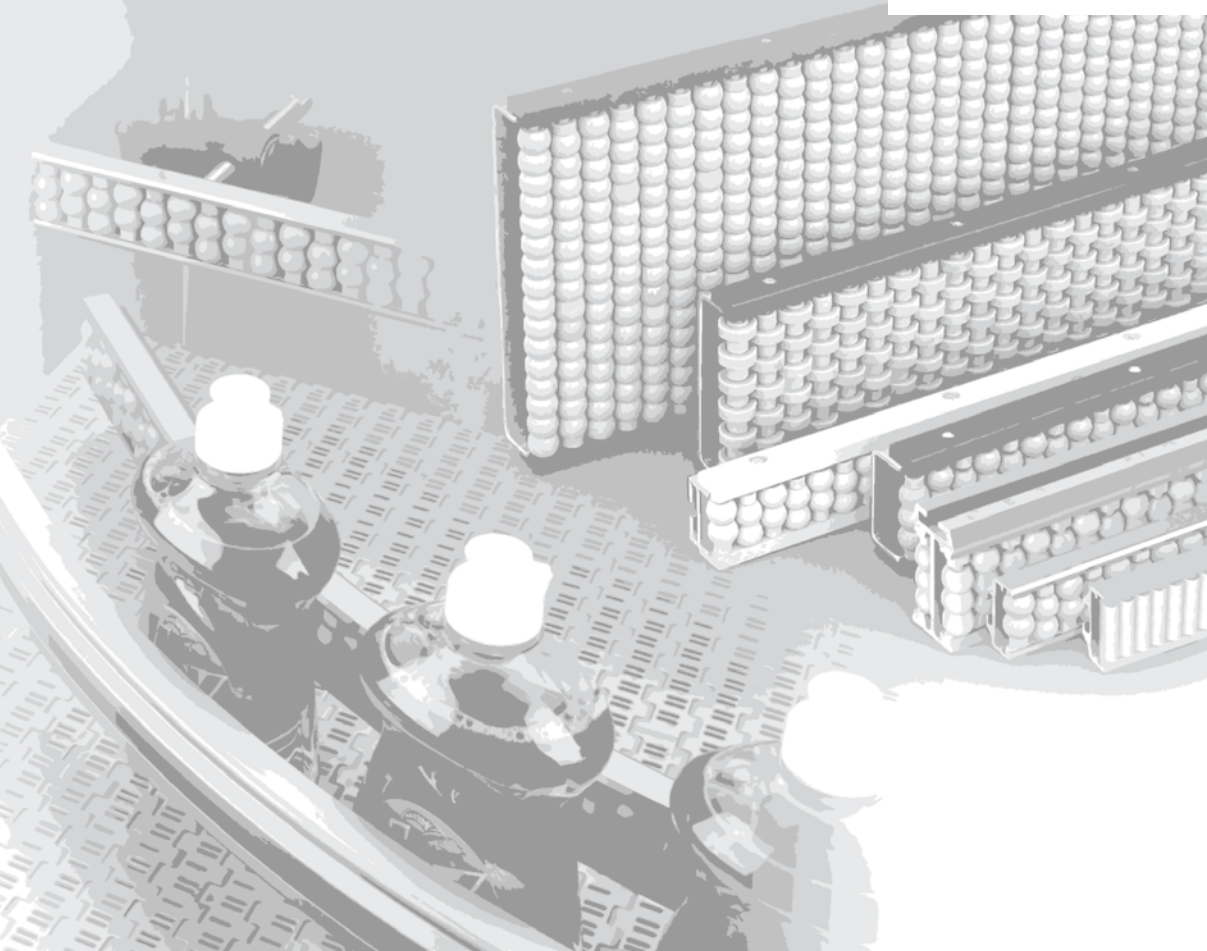

- 
Lane Divider ...
 Page **279**
- 
BeadWall...
 Page **280**
- 
Heavy Duty BeadWall ...
 Page **281**
- 
Roller Combiner ...
 Page **282**
- 
Bead Guide Accessories
 Page **283**

Low Friction Bead and Roller Guides

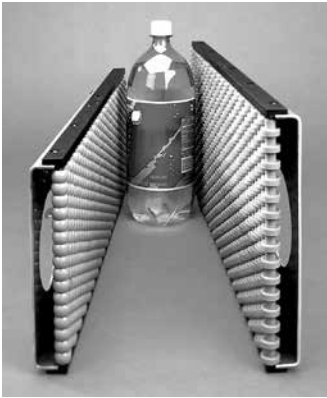

Valu Guide Bead Guides and Combiners are an excellent solution for those areas on a conveying line where containers have trouble moving smoothly and tend to crowd together or jam. The dense pattern of free moving beads or rollers, supported by pins and a metal channel, create a durable, low friction guiding surface. This free rolling action does not allow the package to create any friction points or bridges, which can cause jamming and possibly cause unwanted shutdowns. Our low friction bead guides include light to heavy duty options, each with a wide selection of heights and lengths. Valu Guide bead guides and combin-

ers are also available in custom curved sections. Additional information can be obtained by calling System Plast at (866) 765-8744 or visit www.RegalPTS.com.

- **Eliminates jamming**
- **No friction points or bridging**
- **Increases throughput**
- **Reduces product damage**
- **Excellent for paper, plastic and metal containers**



A SpeedRail™

SpeedRail offers an economical low friction roller guide surface that can be easily modified. The Valu Guide rail bending machine can be used to easily form inner or outer curves. Plus, SpeedRail can be cut to any length between beads. Easy fastening frame slots permit fastening anywhere along the back side of the aluminum channel.

B SpeedRail SB™, SpeedRoll™

Low friction, light duty, small diameter beads or rollers provides excellent guides for polywrapped containers or PET bottles. Can be cut to length and bent using special rollers and the Valu Guide rail bender. Easy fastening frame slots permit fastening anywhere along the back side of the aluminum channel.

C Flexible SpeedRail SB™, SpeedRoll™

SpeedRoll offers a low friction roller guide surface that is great for thin walled aluminum containers or load sensitive items. The Valu Guide rail bending machine can be used to easily form inner or outer curves. Plus, SpeedRoll can be cut to any length between rollers. Easy fastening frame slots permit fastening anywhere along the back side of the aluminum channel.

D BeadRail™

This Economical roller guide can be used for light to medium duty carry surfaces or side rails. Easy fastening frame slots permit fastening anywhere along the back side of the aluminum channel version, or every 6 inches when using a stainless steel channel. Aluminum channels are available in two heights.

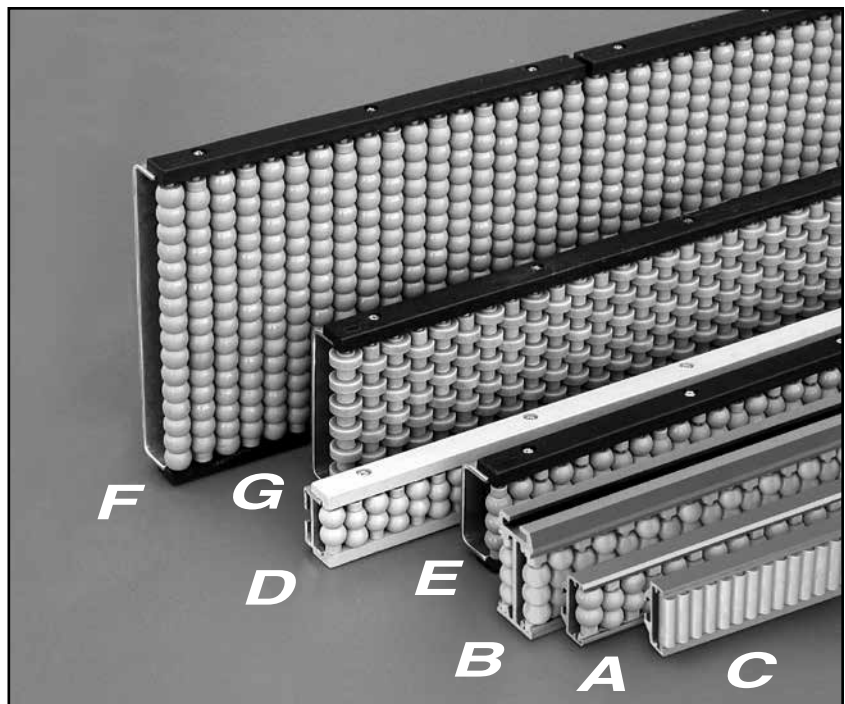

E BeadWall™

This high density bead pattern is our most popular low friction guiding surface. The heavy gauge stainless or plated steel channel construction can withstand significant side loads. Easy fastening frame slots allow for horizontal and vertical BeadWall applications.

F Heavy Duty BeadWall™

For extreme load conditions, Heavy Duty BeadWall is constructed with larger diameter beads and thicker stainless steel pins. These modifications accommodate large load capacities and allow for bead surfaces up to 10 inches.

G Roller Combiner

For applications where a flat contact surface is preferred, Roller Combiner is available with all of the low friction guiding advantages of BeadWall. Available in heights up to 10 inches.

**SYSTEM
PLAST™**

©2015 Regal-Beloit Corporation, All Rights Reserved.

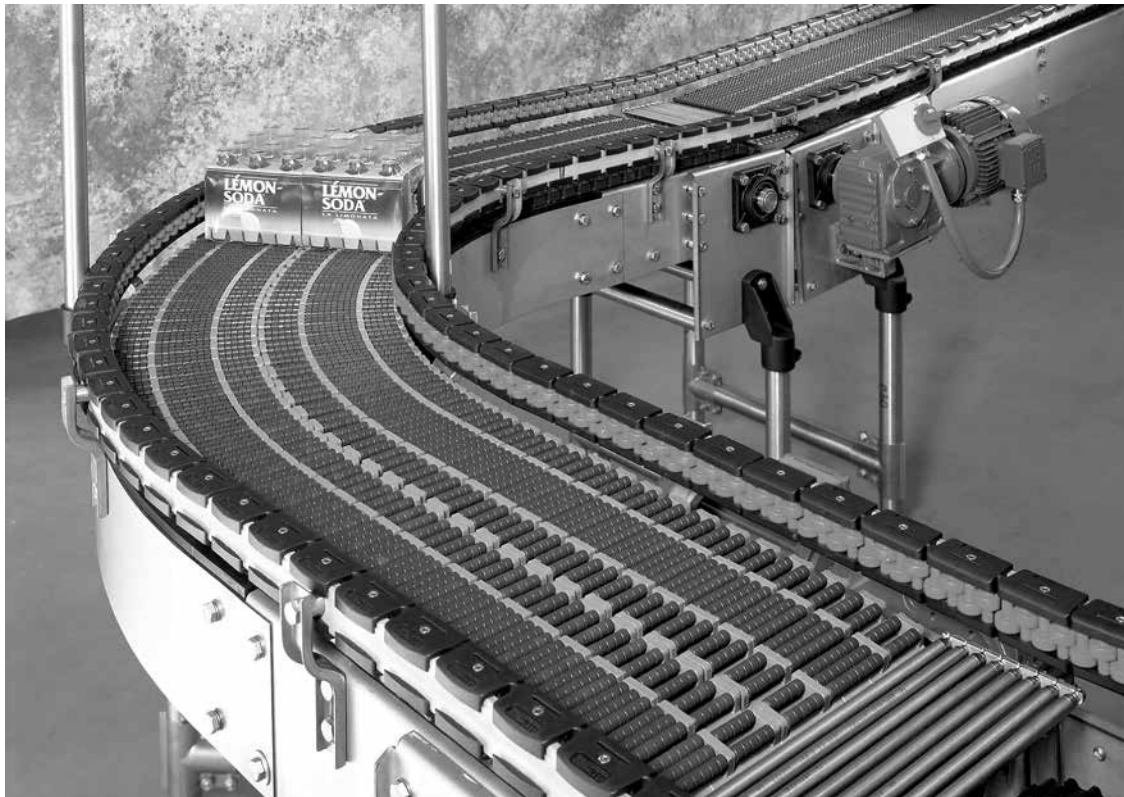

Bead and Roller Guides

Single module

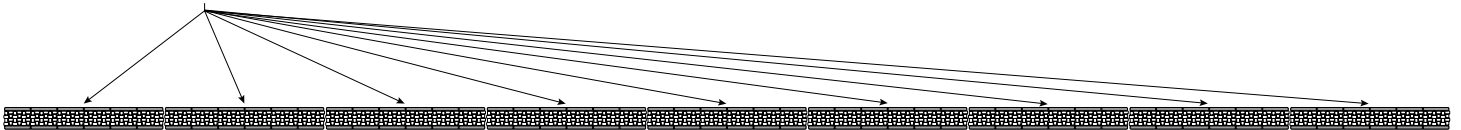
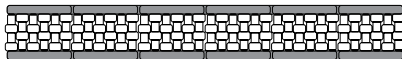

Several single modules assembled onto the M-Profile support (pg. 276) or a steel support to form one 3 meter (approx. 10 ft.) section

These low noise, long life, bead guides offer quick installation and smooth operation. They are designed for boxes and containers (glass and plastic bottles, tin and strong aluminum cans). Excellent for accumulation areas. Can be cut to length.

- ***Eliminates jamming***
- ***No friction points or bridging***
- ***Increases throughput***
- ***Reduces product damage***
- ***Excellent for paper, plastic and metal containers***

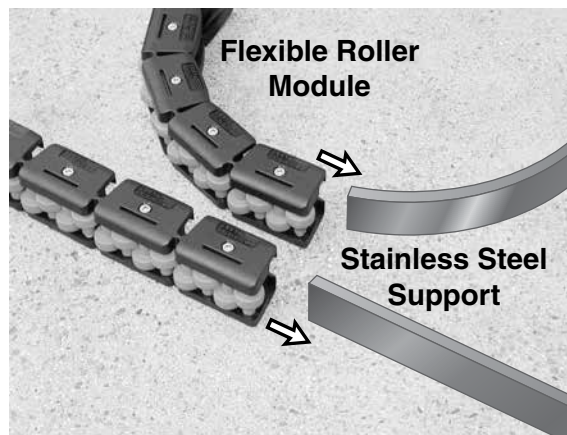

Modules slide onto 40mm x 8 mm flat bars or the M-Profile. Minimum radius for a curved section is 10 in. (beads outside) and 12 in. (beads inside).



Applications for Bead and Roller Guides

Single Filer

Top view of combiner application for round cans, glass or plastic bottles using Roller Combiner and Valu Guide brackets and rods.

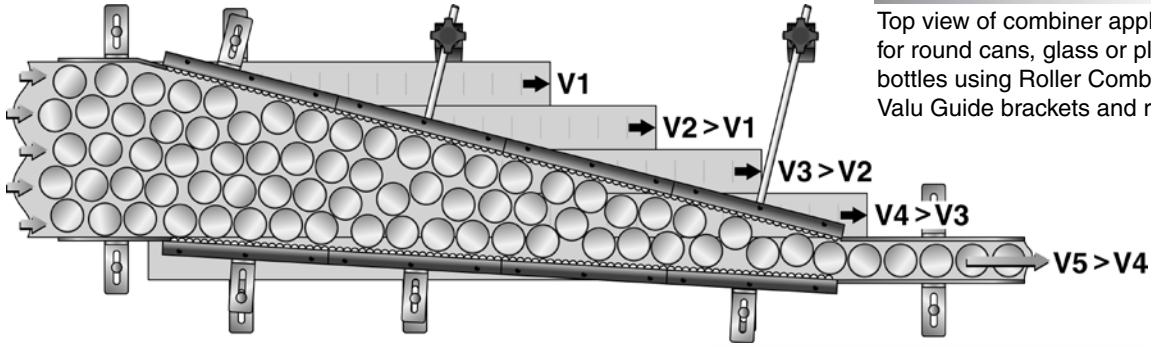

Transfer

Smoothly guides containers from one conveyor to another, minimizing tipping and jams.

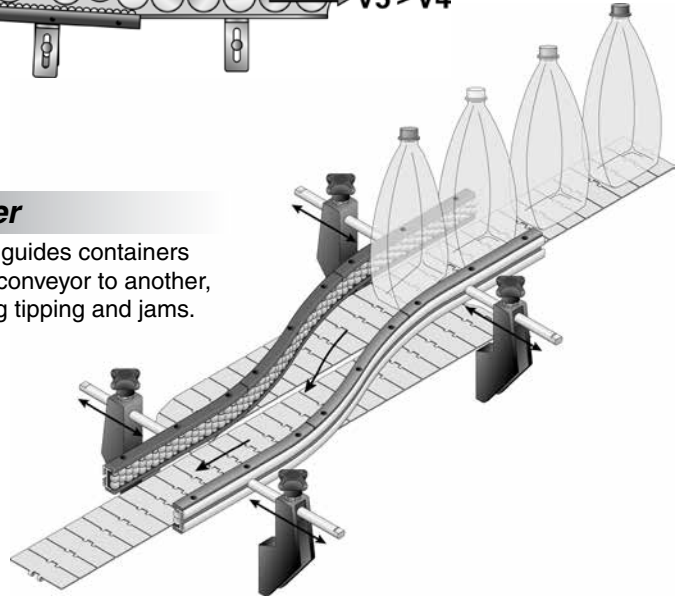

Bead and Roller Guides

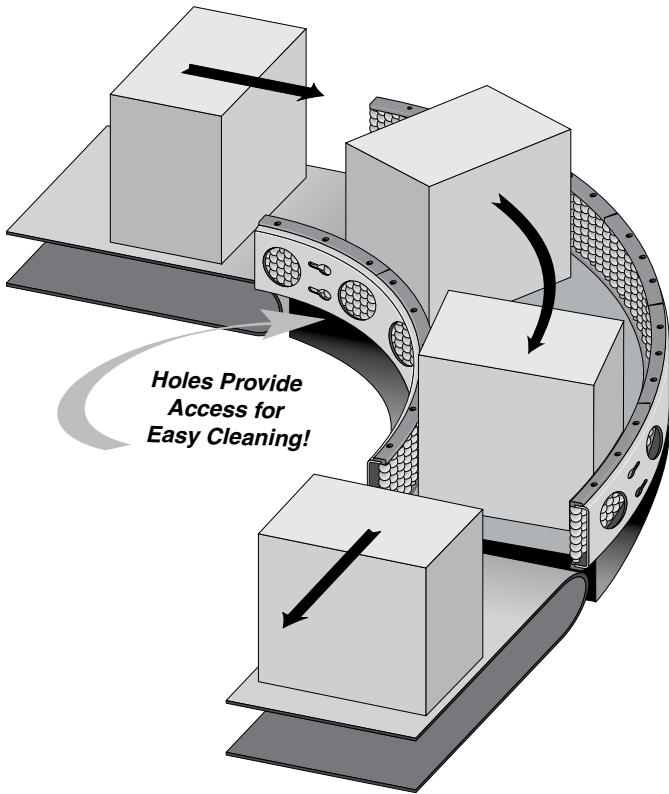

Maintaining Orientation

In straights or especially in curved sections, BeadWall does an excellent job of keeping packages or containers oriented correctly.

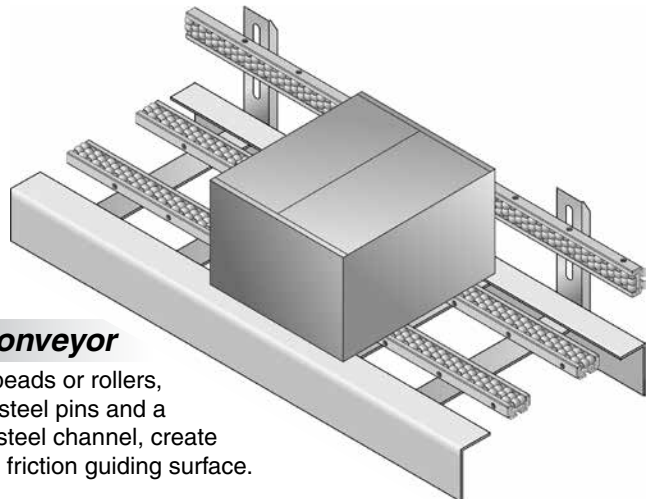

Gravity Conveyor

Free moving beads or rollers, supported by steel pins and a heavy gauge steel channel, create a durable, low friction guiding surface.



687-1.4

SpeedRail SB™ Lane Divider

Low friction 2-sided beaded lane divider provides excellent guides for polywrapped containers or PET bottles. Can be cut to length and bent using special rollers and the Valu Guide rail bender. Easy mounting using VG-1568-02 bolts (included). Operating temperature range: -10°F to +180°F.



Patent No.
6,516,933
6,991,086,B2

VG-1568-02
included
(see page 284)

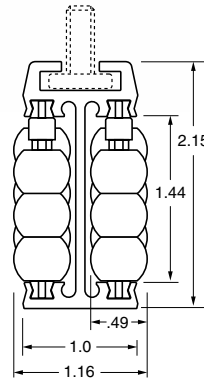
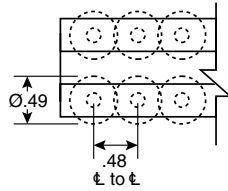
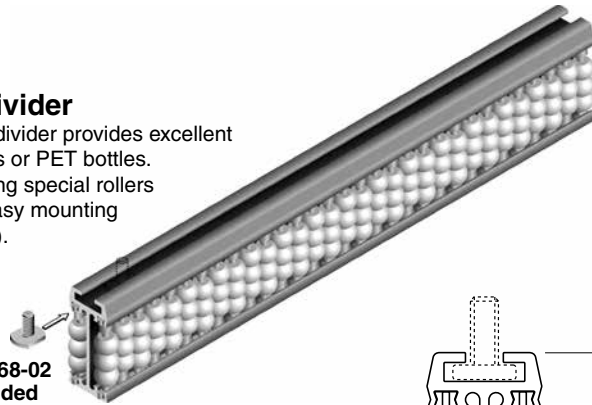

min. bending radius in either direction. Field bendable with Valu Guide rail bender on pg. 220 or custom bend request form on pg. 287.

- Easy mounting
- Great for polywrapped containers or PET
- On-site bendable
- Cut to desired length

Material: Aluminum channel, FDA accepted engineered polymer pins, gray acetal beads.

Part Number	No. of Bolts Included*	Length (ft.)
VG-687-1.4-02	3	2
VG-687-1.4-03	3	3
VG-687-1.4-04	3	4
VG-687-1.4-05	4	5
VG-687-1.4-06	4	6
VG-687-1.4-07	5	7
VG-687-1.4-08	5	8
VG-687-1.4-10	6	10

*Bolts included are VG-1568-02

Bead and Roller Guides

687H-1.4

SpeedRail SB™

Low friction beads provide excellent guides for polywrapped containers or PET bottles. Smaller beads help guide smaller containers. Can be cut to length and bent using special rollers and the Valu Guide rail bender. Easy mounting using VG-1568-02 bolts (included). Operating temperature range: -10°F to +180°F.



Patent No.
6,516,933
6,991,086,B2

VG-1568-02
included
(see page 284)

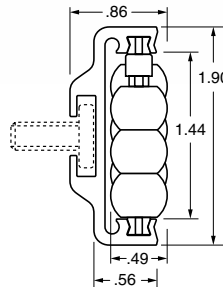
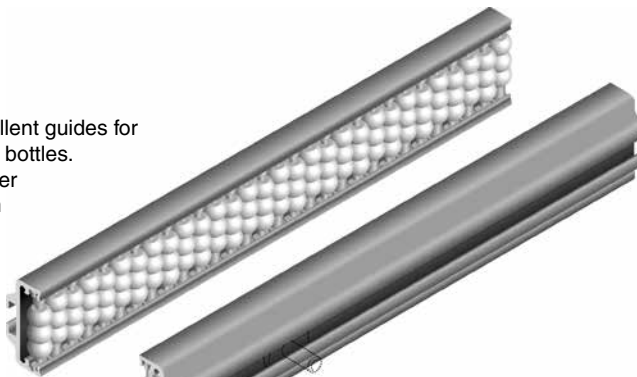

min. bending radius in either direction. Field bendable with Valu Guide rail bender on pg. 220 or custom bend request form on pg. 287.

Material: Aluminum channel, FDA accepted engineered polymer pins, gray acetal beads.

Part Number	No. of Bolts Included*	Length (ft.)
VG-687H-1.4-02	3	2
VG-687H-1.4-03	3	3
VG-687H-1.4-04	3	4
VG-687H-1.4-05	4	5
VG-687H-1.4-06	4	6
VG-687H-1.4-07	5	7
VG-687H-1.4-08	5	8
VG-687H-1.4-09	6	9
VG-687H-1.4-10	6	10

*Bolts included are VG-1568-02

687-3.3 2-Strand SpeedRail SB™ Lane Divider

Low friction 2-sided beaded lane divider provide excellent guides for polywrapped containers or PET bottles. Can be cut to length. Custom bends can be ordered from the factory. Easy mounting using VG-1568-02 bolts (included). Operating temperature range: -10°F to +180°F.



Patent No.
6,516,933
6,991,086,B2

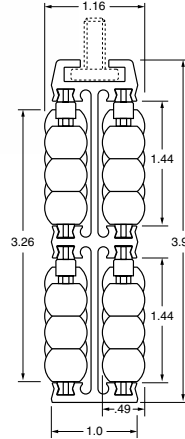
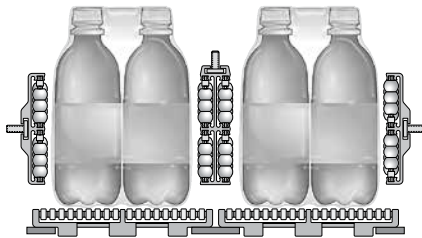
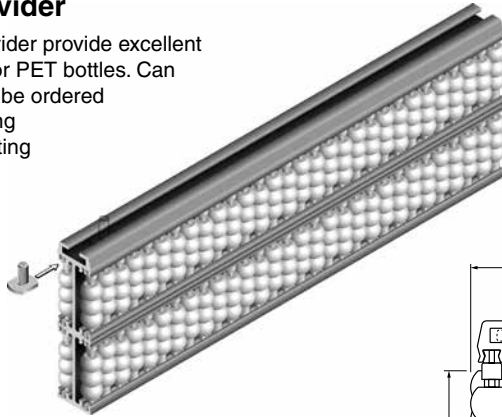

Material: Aluminum channel, FDA accepted engineered polymer pins, gray acetal beads.

Part Number	No. of Bolts Included*	Length (ft.)
VG-687-3.3-02	3	2
VG-687-3.3-03	3	3
VG-687-3.3-04	3	4
VG-687-3.3-05	4	5
VG-687-3.3-06	4	6
VG-687-3.3-07	5	7
VG-687-3.3-08	5	8
VG-687-3.3-09	6	9
VG-687-3.3-10	6	10

*Bolts included are VG-1568-02



687SP

SpeedRail SB™ Splicing Pins

For use with:
VG-687-1.4-...
VG-687H-1.4-...
VG-687-3.3-...
VG-687H-3.3-...

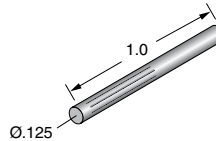
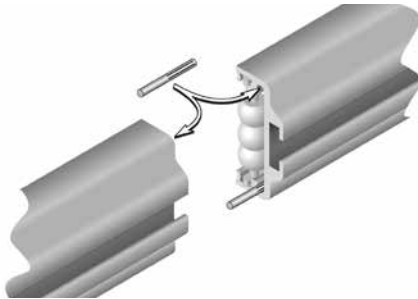

Material: Stainless steel.

Part Number
VG-687SP

687H-3.3 2-Strand SpeedRail SB™

A wider bead guide used for carry surfaces or side rails. Low friction beads provide excellent guides for polywrapped containers or PET bottles. Smaller beads help guide smaller containers. Can be cut to length. Custom bends can be ordered from the factory. Easy mounting using VG-1568-02 bolts (included). Operating temp. range: -10°F to +180°F.



Patent No.
6,516,933
6,991,086,B2

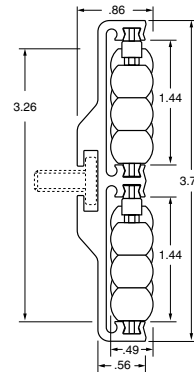
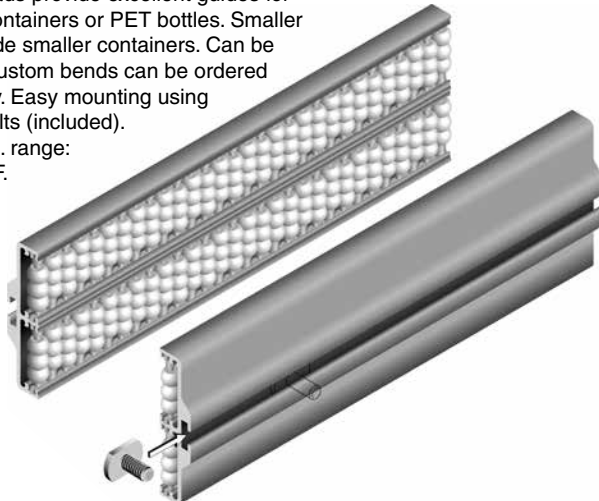

Material: Aluminum channel, FDA accepted engineered polymer pins, gray acetal beads.

Part Number	No. of Bolts Included*	Length (ft.)
VG-687H-3.3-02	3	2
VG-687H-3.3-03	3	3
VG-687H-3.3-04	3	4
VG-687H-3.3-05	4	5
VG-687H-3.3-06	4	6
VG-687H-3.3-07	5	7
VG-687H-3.3-08	5	8
VG-687H-3.3-09	6	9
VG-687H-3.3-10	6	10

*Bolts included are VG-1568-02

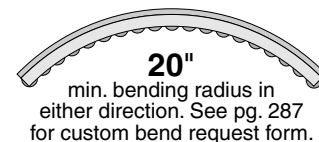



687FLEX-1.4

Flexible SpeedRail SB™

Bend by hand to create corners or S-curves easily. Low friction beads provide excellent guides for polywrapped containers or PET bottles. Smaller beads help guide smaller containers. Can be cut to length. Easy mounting using VG-1568-02 bolts (included). Operating temperature range: -10°F to +180°F.

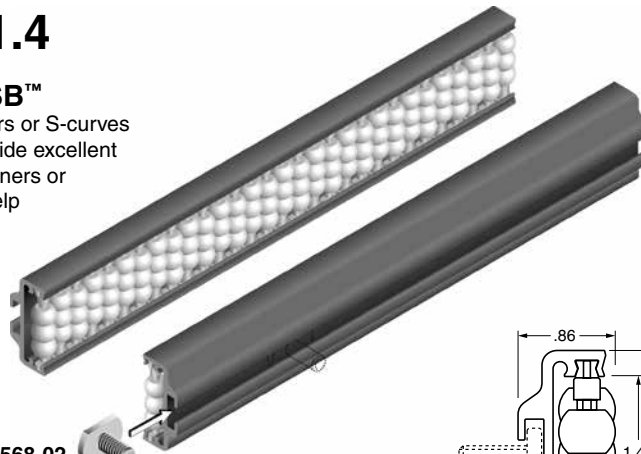

VG-1568-02 included (see page 284)



Patent No.
6,516,933
7,147,098,B2

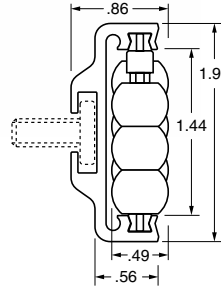

Material: PVC channel, FDA accepted engineered polymer pins, gray acetal beads.

Part Number	No. of Bolts Included*	Length (ft.)
VG-687FLEX-1.4-02	3	2
VG-687FLEX-1.4-03	3	3
VG-687FLEX-1.4-04	3	4
VG-687FLEX-1.4-05	4	5
VG-687FLEX-1.4-06	4	6
VG-687FLEX-1.4-07	5	7
VG-687FLEX-1.4-08	5	8
VG-687FLEX-1.4-09	6	9
VG-687FLEX-1.4-10	6	10

*Bolts included are VG-1568-02

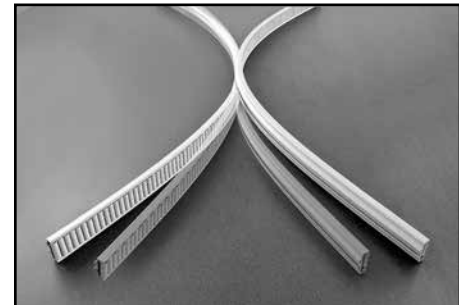
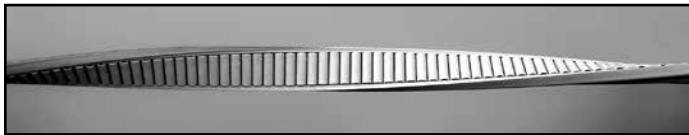

Bead and Roller Guides

688FLEX-1.4

Flexible SpeedRoll™

Bend by hand to create corners or S-curves easily. Low friction beads provide excellent guides for polywrapped containers or PET bottles. Smaller beads help guide smaller containers. Can be cut to length. Easy mounting using VG-1568-02 bolts (included). Operating temperature range: -10°F to +180°F.

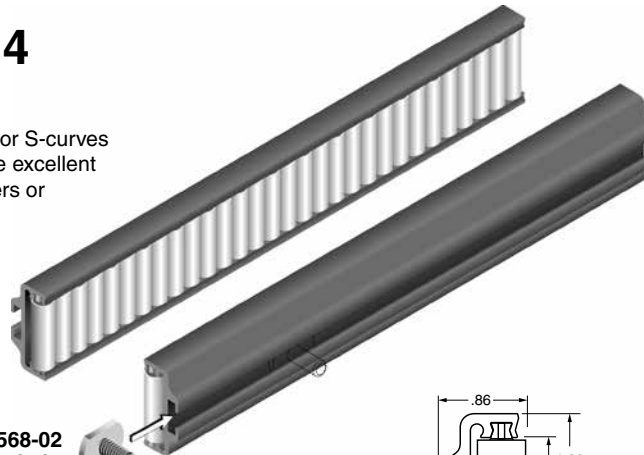

VG-1568-02 included (see page 284)



Patent No.
6,516,933
7,147,098,B2

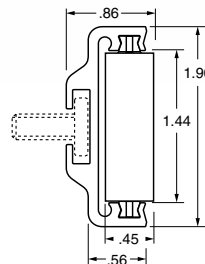

Material: PVC channel, FDA accepted engineered polymer pins, gray acetal rollers.

Part Number	No. of Bolts Included*	Length (ft.)
VG-688FLEX-1.4-02	3	2
VG-688FLEX-1.4-03	3	3
VG-688FLEX-1.4-04	3	4
VG-688FLEX-1.4-05	4	5
VG-688FLEX-1.4-06	4	6
VG-688FLEX-1.4-07	5	7
VG-688FLEX-1.4-08	5	8
VG-688FLEX-1.4-09	6	9
VG-688FLEX-1.4-10	6	10

*Bolts included are VG-1568-02



688-1.4

SpeedRoll™ Lane Divider

2-sided lane divider with low friction rollers provides excellent guides for polywrapped containers or PET bottles. Can be cut to length and bent using special rollers and the Valu Guide rail bender. Easy mounting using VG-1568-02 bolts (included). Operating temperature range: -10°F to +180°F.



Patent No.
6,516,933
6,991,086,B2

VG-1568-02
included
(see page 284)

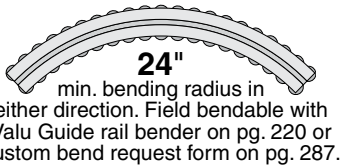
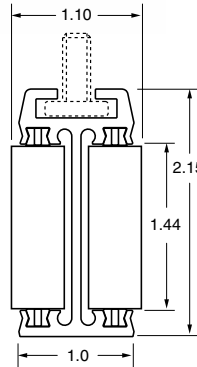
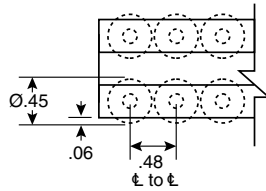
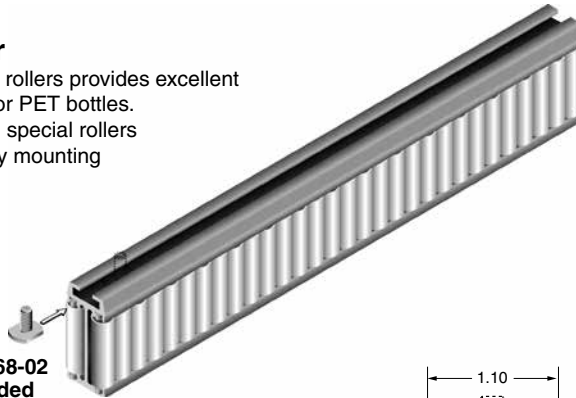

Bead and Roller Guides

- Easy mounting
- Great for polywrapped containers or PET
- On-site bendable
- Cut to desired length

Material: Aluminum channel, FDA accepted engineered polymer pins, gray acetal rollers.

Part Number	No. of Bolts Included*	Length (ft.)
VG-688-1.4-02	3	2
VG-688-1.4-03	3	3
VG-688-1.4-04	3	4
VG-688-1.4-05	4	5
VG-688-1.4-06	4	6
VG-688-1.4-07	5	7
VG-688-1.4-08	5	8
VG-688-1.4-10	6	10

*Bolts included are VG-1568-02

688H-1.4

Aluminium SpeedRoll™

Low friction rollers provide excellent guides for polywrapped containers or PET bottles. Can be cut to length and bent using special rollers and the Valu Guide rail bender. Easy mounting using VG-1568-02 bolts (included). Operating temperature range: -10°F to +180°F.



Patent No.
6,516,933
6,991,086,B2

VG-1568-02
included
(see page 284)

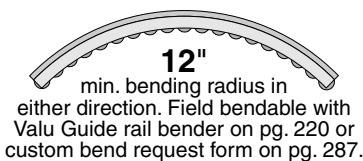
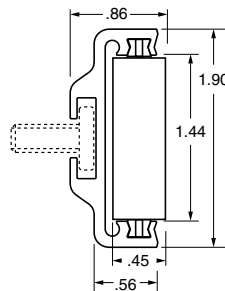

Material: Aluminum channel, FDA accepted engineered polymer pins, gray acetal rollers.

Part Number	No. of Bolts Included*	Length (ft.)
VG-688H-1.4-02	3	2
VG-688H-1.4-03	3	3
VG-688H-1.4-04	3	4
VG-688H-1.4-05	4	5
VG-688H-1.4-06	4	6
VG-688H-1.4-07	5	7
VG-688H-1.4-08	5	8
VG-688H-1.4-09	6	9
VG-688H-1.4-10	6	10

*Bolts included are VG-1568-02



688-3.3

2-Strand SpeedRoll™ Lane Divider

2-sided lane divider with low friction rollers provides excellent guides for polywrapped containers or PET bottles. Can be cut to length. Custom bends can be ordered from the factory. Easy mounting using VG-1568-02 bolts (included). Operating temperature range: -10°F to +180°F.

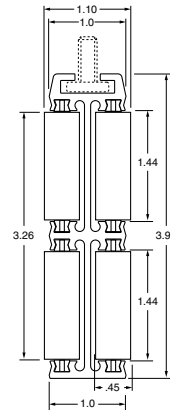
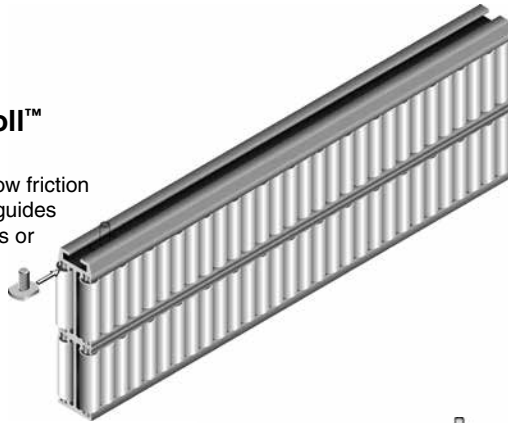

Patent No.
6,516,933
6,991,086,B2

Material: Aluminum channel, FDA accepted engineered polymer pins, gray acetal rollers.

Part Number	No. of Bolts Included*	Length (ft.)
VG-688-3.3-02	3	2
VG-688-3.3-03	3	3
VG-688-3.3-04	3	4
VG-688-3.3-05	4	5
VG-688-3.3-06	4	6
VG-688-3.3-07	5	7
VG-688-3.3-08	5	8
VG-688-3.3-10	6	10

*Bolts included are VG-1568-02



687SP

SpeedRoll™ Splicing Pins

For use with:
VG-688-1.4-...
VG-688H-1.4-...
VG-688-3.3-...
VG-688H-3.3-...

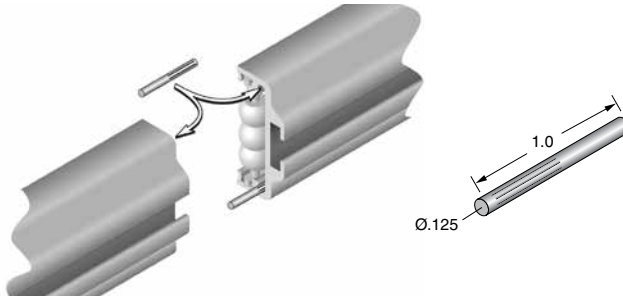

Material: Stainless steel.

Part Number

VG-687SP

Bead and Roller Guides

688H-3.3

2-Strand Aluminum SpeedRoll™

A wider roller guide used for carry surfaces or side rails. Low friction rollers provide excellent guides for polywrapped containers or PET bottles. Can be cut to length. Custom bends can be ordered from the factory. Easy mounting using VG-1568-02 bolts (included). Operating temp. range: -10°F to +180°F.

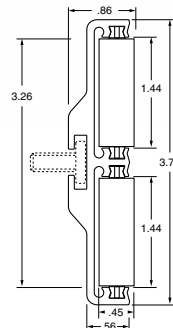
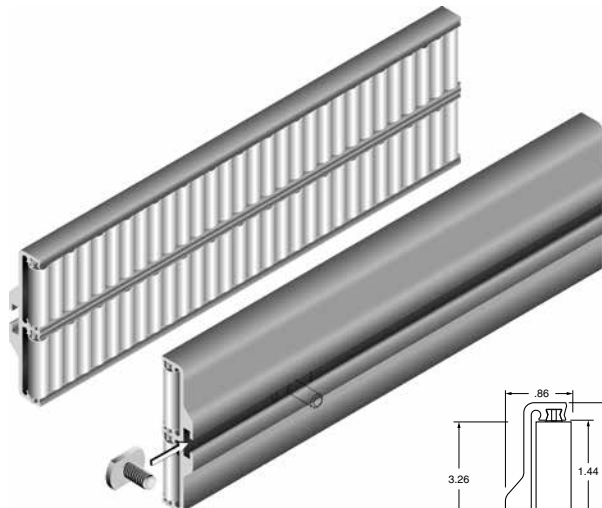

Material: Aluminum channel, FDA accepted engineered polymer pins, gray acetal rollers.

Part Number	No. of Bolts Included*	Length (ft.)
VG-688H-3.3-02	3	2
VG-688H-3.3-03	3	3
VG-688H-3.3-04	3	4
VG-688H-3.3-05	4	5
VG-688H-3.3-06	4	6
VG-688H-3.3-07	5	7
VG-688H-3.3-08	5	8
VG-688H-3.3-10	6	10

*Bolts included are VG-1568-02

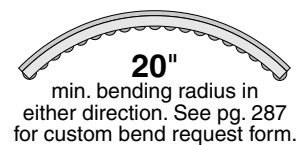

Patent No.
6,516,933
6,991,086,B2



686A-1.25



SpeedRail™

Economical bead guide used for carry surfaces or side rails. Use Valu Guide Rail Bender to form inner and outer curves. Can be cut to any length between beads. Easy fastening frame slot for horizontal and vertical applications. Operating temperature range: -10°F to +180°F.



Patent No.
6,516,933
6,991,086,B2

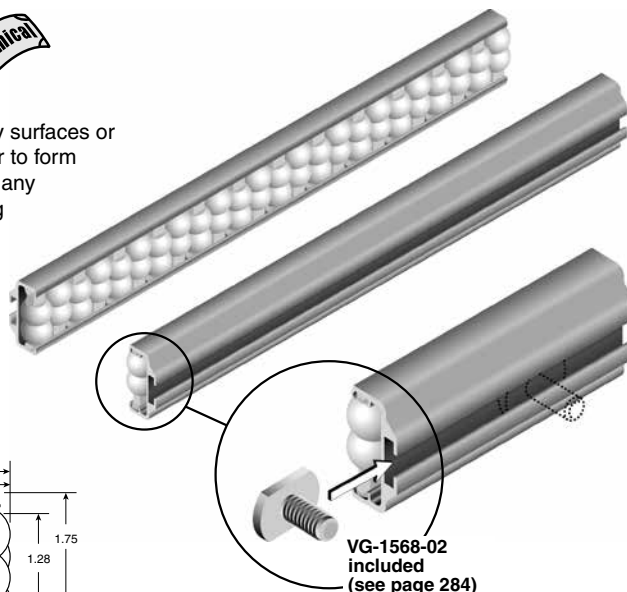
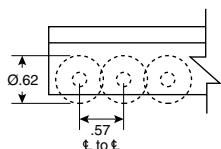
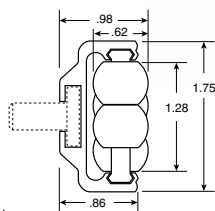

VG-1568-02 included (see page 284)

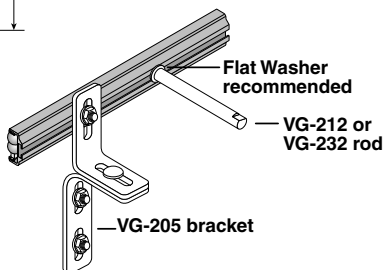

Flat Washer recommended

VG-212 or VG-232 rod

VG-205 bracket

Material: Aluminum channel, FDA accepted engineered polymer pins, gray acetal beads.

Part Number	No. of Bolts Included*	Length (ft.)
VG-686A-1.25-02	3	2
VG-686A-1.25-03	3	3
VG-686A-1.25-04	3	4
VG-686A-1.25-05	4	5
VG-686A-1.25-06	4	6
VG-686A-1.25-07	5	7
VG-686A-1.25-08	5	8
VG-686A-1.25-09	6	9
VG-686A-1.25-10	6	10

*Bolts included are VG-1568-02



12"
min. bending radius in either direction. Field bendable with Valu Guide rail bender on pg. 220 or custom bend request form on pg. 287.

686A-3.0

2-Strand SpeedRail™

A wider bead guide used for carry surfaces or side rails. Can be cut to any length between beads. Custom bends can be ordered from the factory. Easy fastening frame slot for horizontal and vertical applications. Operating temperature range: -10°F to +180°F.



Patent No.
6,516,933
6,991,086,B2

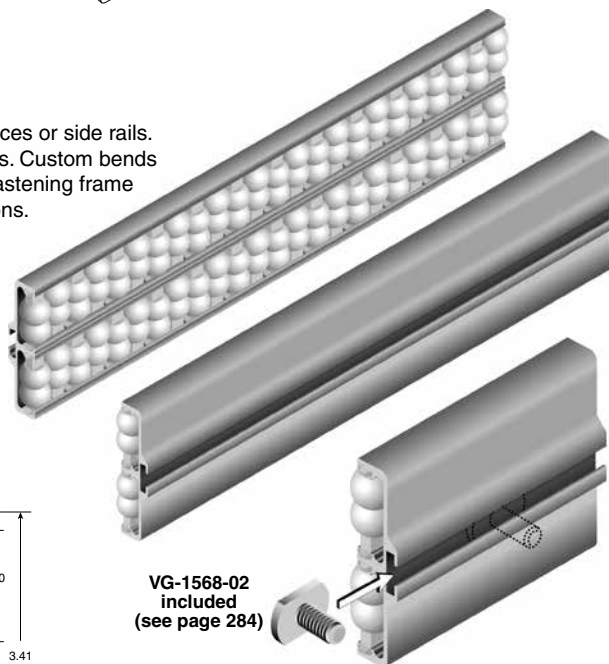
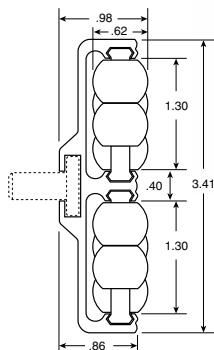

VG-1568-02 included (see page 284)

Material: Aluminum channel, FDA accepted engineered polymer pins, gray acetal beads.

Part Number	No. of Bolts Included*	Length (ft.)
VG-686A-3.0-02	3	2
VG-686A-3.0-03	3	3
VG-686A-3.0-04	3	4
VG-686A-3.0-05	4	5
VG-686A-3.0-06	4	6
VG-686A-3.0-07	5	7
VG-686A-3.0-08	5	8
VG-686A-3.0-09	6	9
VG-686A-3.0-10	6	10

*Bolts included are VG-1568-02



20"
min. bending radius in either direction. See pg. 287 for custom bend request form.



BR-1.5

Aluminum Channel BeadRail™

Economical bead guide used for carry surfaces or side rails. Easy fastening frame slot for horizontal and vertical applications. Operating temperature range: -4°F to +170°F.

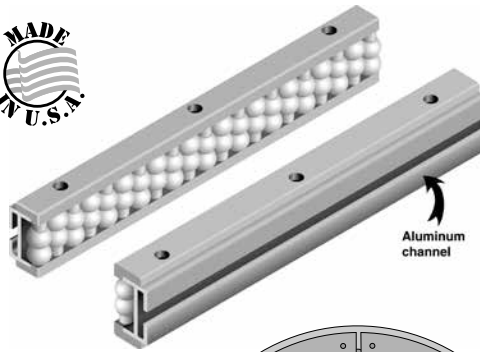

Material: Aluminum channel, gray polyamide pin rails, carbon steel pins, gray acetal beads.

Part Number	Length (ft.)
VG-684BR-1.5-AB-02	2
VG-684BR-1.5-AB-03	3
VG-684BR-1.5-AB-04	4
VG-684BR-1.5-AB-05	5
VG-684BR-1.5-AB-06	6
VG-684BR-1.5-AB-07	7
VG-684BR-1.5-AB-08	8
VG-684BR-1.5-AB-09	9
VG-684BR-1.5-AB-10	10

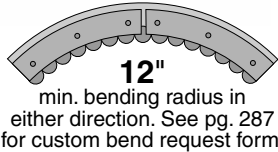
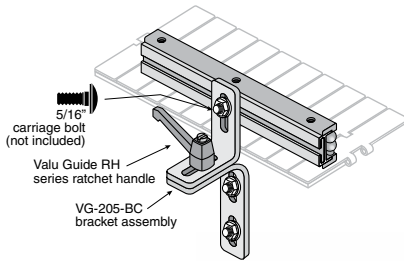
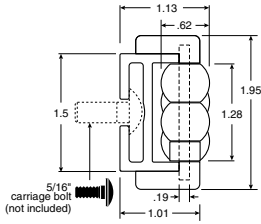

BR-3

3 Inch Aluminum Channel BeadRail™

Economical bead guide used for carry surfaces or side rails. Easy fastening frame slot for horizontal and vertical applications. Operating temperature range: -4°F to +170°F.

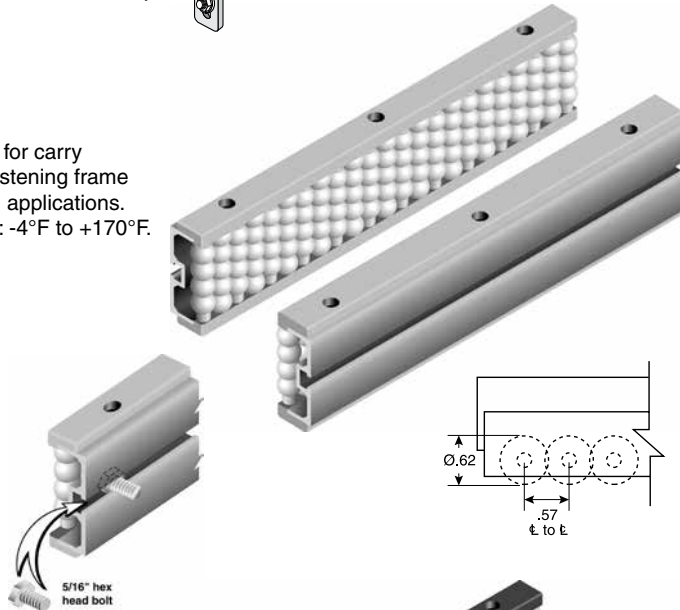
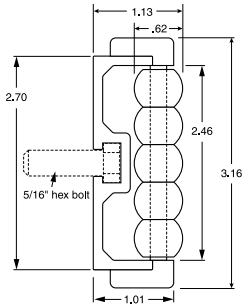

Material: Aluminum channel, gray polyamide pin rails, carbon steel pins, gray acetal beads.

Part Number	Length (ft.)
VG-684BR-3-AB-02	2
VG-684BR-3-AB-03	3
VG-684BR-3-AB-04	4
VG-684BR-3-AB-05	5
VG-684BR-3-AB-06	6
VG-684BR-3-AB-07	7
VG-684BR-3-AB-08	8
VG-684BR-3-AB-09	9
VG-684BR-3-AB-10	10

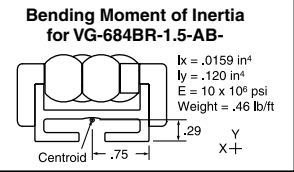

Bead and Roller Guides

BR-1.5

Stainless Steel Channel BeadRail™

Economical bead guide used for carry surfaces or side rails. Easy fastening frame slots for horizontal and vertical applications. Operating temperature range: -4°F to +170°F.

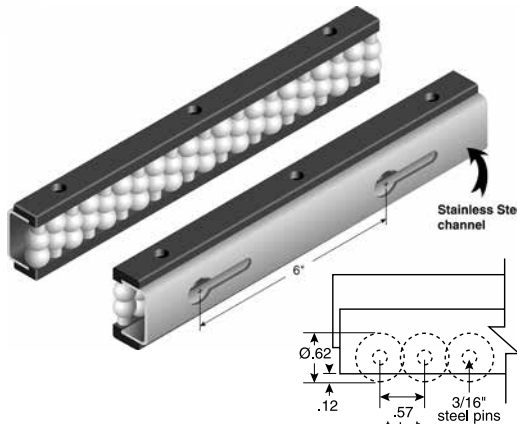
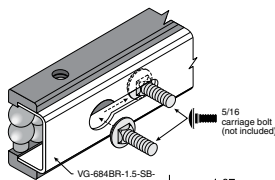

Material: 14 ga. Stainless steel channel, black polyamide pin rails, stainless steel pins, tan acetal beads.

Part Number	Length (ft.)
VG-684BR-1.5-SB-02	2
VG-684BR-1.5-SB-03	3
VG-684BR-1.5-SB-04	4
VG-684BR-1.5-SB-05	5
VG-684BR-1.5-SB-06	6
VG-684BR-1.5-SB-07	7
VG-684BR-1.5-SB-08	8
VG-684BR-1.5-SB-10	10

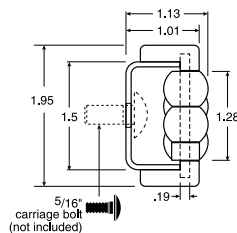
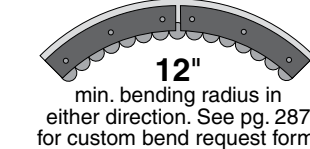
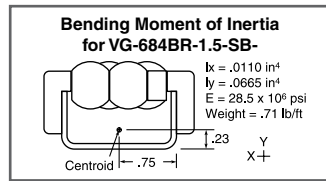



16600 series

Single, Flexible Roller Module

These low noise, long life, bead guides offer quick installation and smooth operation. They are designed for boxes and containers (glass and plastic bottles, tin and strong aluminum cans). Excellent for accumulation areas.

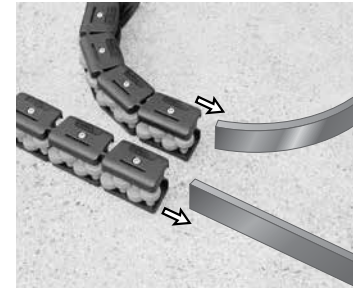
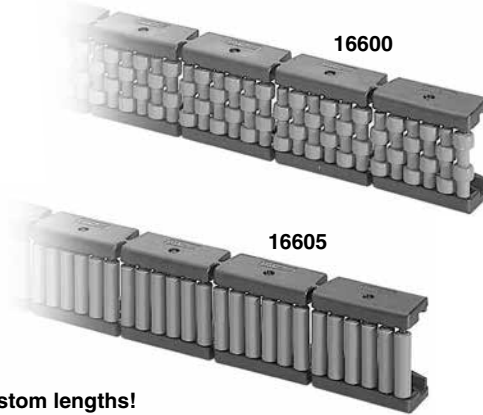

Modules slide onto 40mm x 8 mm flat bars or the "M" profile below. Minimum radius for a curved section is 10 in. (beads outside) and 12 in. (beads inside).

Combine these single modules together to fit custom lengths!

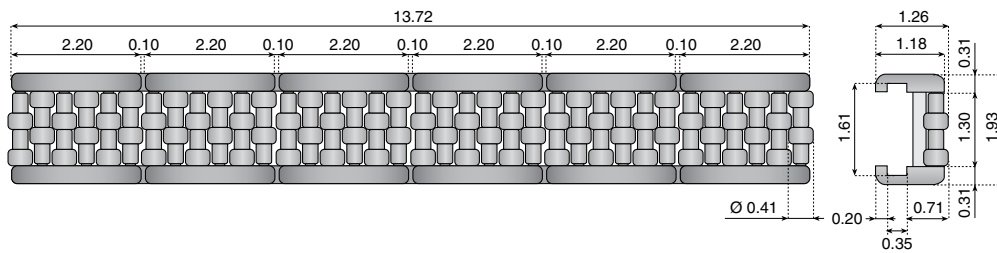

Material: Polyamide straps, acetal rollers and pins, nickel plated brass spacers, stainless steel screws.

Part Number	Type	Length (inches)
16600	beads	13.72
16605	rollers	13.72

Bead and Roller Guides

Flexible Roller Assembly with Stainless Steel Support

These low noise, long life, bead guides offer quick installation and smooth operation. They are designed for boxes and containers (glass and plastic bottles, tin and strong aluminum cans). Excellent for accumulation areas. Can be cut to length.

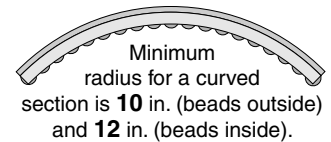
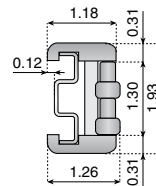
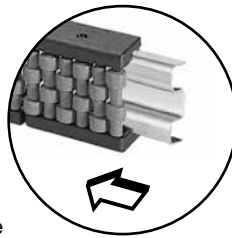

3 meter assembled section!

Material: Stainless steel channel. Polyamide straps, acetal rollers and pins, nickel plated brass spacers, stainless steel screws.

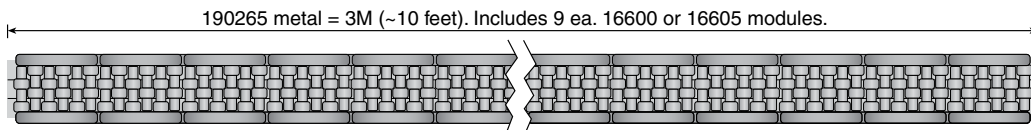

190265 metal = 3M (~10 feet). Includes 9 ea. 16600 or 16605 modules.

Part Number	Type	Length
16655K	beads	3M (~10 ft.)
16656K	rollers	3M (~10 ft.)

190

M-Profile

Stainless steel support for roller modules. See page 221 for compatible bender rollers.

- Inexpensive
- Corrosion resistant
- On-site bendable

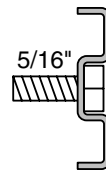
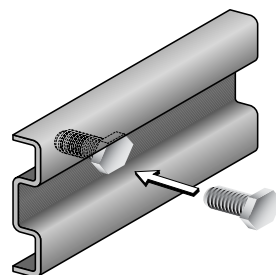
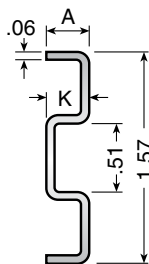

Can be mounted by drilling a hole through the steel support. Use a 5/16" hex head to fasten.

Material: 304 stainless steel.

Part Number	A	K	Length
19077	.23	.39	3M (~10 ft.)
190265	.31	.31	3M (~10 ft.)
19079	.39	.39	3M (~10 ft.)



16800 series

Flexible Roller Module

These low noise, long life, bead guides offer quick installation and smooth operation. They are designed for boxes and containers (glass and plastic bottles, tin and strong aluminum cans). Excellent for accumulation areas.

Combine these single modules together to fit custom lengths!

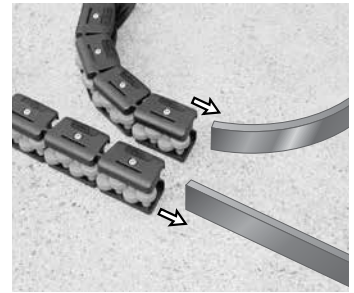
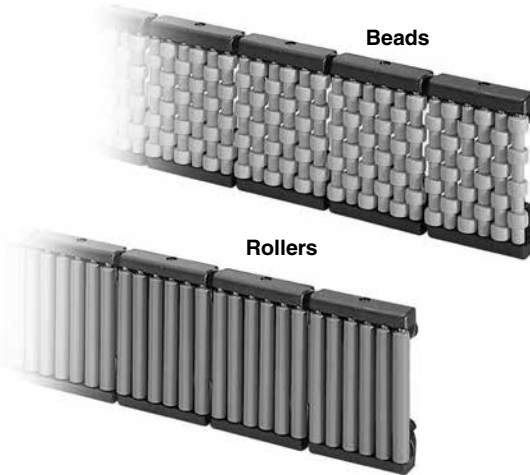

Modules slide onto 40mm x 8 mm flat bars or the "M" profile below. Minimum radius for a curved section is 10 in. (beads outside) and 12 in. (beads inside).

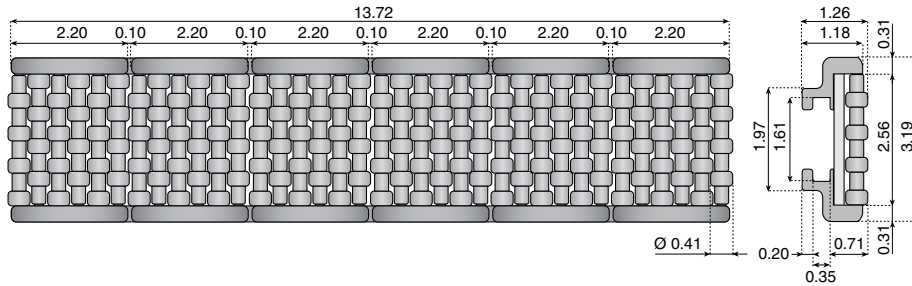

Material: Polyamide straps, white acetal rollers and pins, nickel plated brass spacers, stainless steel screws.

Part Number	Type	Length (inches)
16800K	beads	13.72
16805K	rollers	13.72

Flexible Roller Assembly with Stainless Steel Support

These low noise, long life, bead guides offer quick installation and smooth operation. They are designed for boxes and containers (glass and plastic bottles, tin and strong aluminum cans). Excellent for accumulation areas. Can be cut to length.

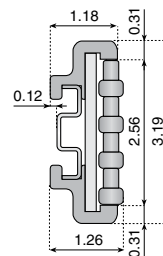
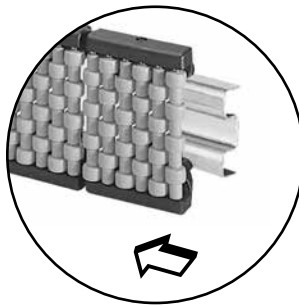

Minimum radius for a curved section is 10 in. (beads outside) and 12 in. (beads inside).

Material: Stainless steel channel, polyamide straps, white acetal rollers and pins, nickel plated brass spacers, stainless steel screws.

Part Number	Type	Length
16825K	beads	3M (~10 ft.)
16826K	rollers	3M (~10 ft.)

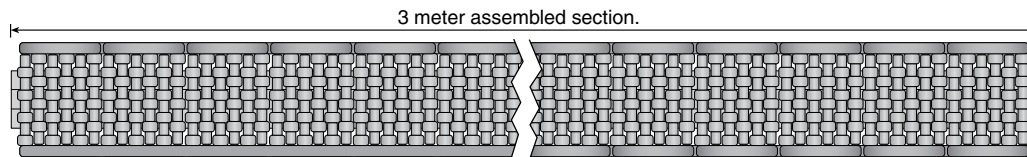

190

M-Profile

Stainless steel support for roller modules. See page 221 for compatible bender rollers.

- Inexpensive
- Corrosion resistant
- On-site bendable

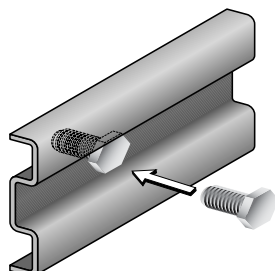
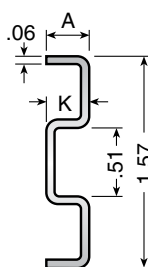

Can be mounted by drilling a hole through the steel support. Use a 5/16" hex head to fasten.

Material: 304 stainless steel.

Part Number	A	K	Length
19077	.23	.39	3M (~10 ft.)
190265	.31	.31	3M (~10 ft.)
19079	.39	.39	3M (~10 ft.)



16500 series

Heavy Duty, Single, Flexible Roller Module

These low noise, long life, bead guides offer quick installation and smooth operation. They are designed for rugged boxes and containers. Excellent for accumulation areas.

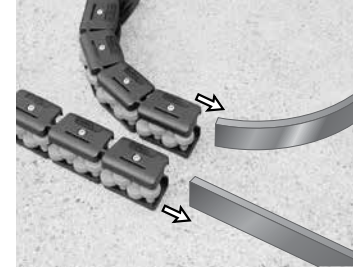

Modules slide onto 40mm x 8 mm flat bars or the "M" profile below. Minimum radius for a curved section is 10 in. (beads outside) and 12 in. (beads inside).

Combine these single modules together to fit custom lengths!

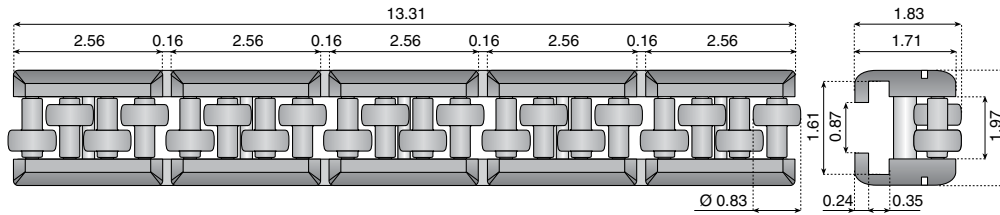

Material: Polyamide straps, acetal rollers and pins, nickel plated brass spacers, stainless steel screws.

Part Number	Length (inches)
16500	13.31

Bead and Roller Guides

Heavy Duty, Flexible Roller Assembly with Stainless Steel Support

These low noise, long life, bead guides offer quick installation and smooth operation. They are designed for rugged boxes and containers. Excellent for accumulation areas. Can be cut to length.



3 meter assembled section!

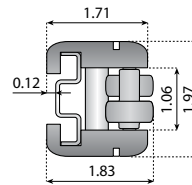

Minimum radius for a curved section is 10 in. (beads outside) and 12 in. (beads inside).

Material: Stainless steel channel. Polyamide straps, acetal rollers and pins, nickel plated brass spacers, stainless steel screws.

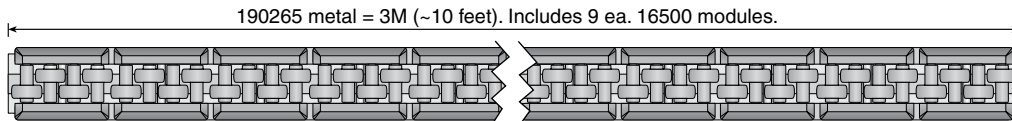

Part Number	Length (feet)
16550	3M (~10 ft.)

190

M-Profile

Stainless steel support for roller modules. See page 221 for compatible bender rollers.

- Inexpensive
- Corrosion resistant
- On-site bendable

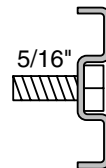
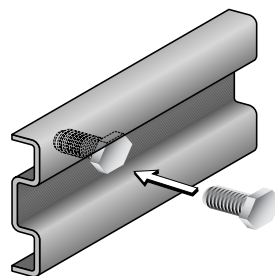
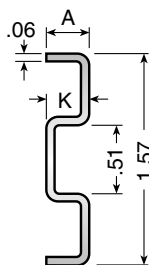

Can be mounted by drilling a hole through the steel support. Use a 5/16" hex head to fasten.

Material: 304 stainless steel.

Part Number	A	K	Length
19077	.23	.39	3M (~10 ft.)
190265	.31	.31	3M (~10 ft.)
19079	.39	.39	3M (~10 ft.)



16152

Lane Divider

These low noise, long life, lane dividers offer quick installation and smooth operation. They are designed for rugged boxes and containers. Excellent for accumulation areas.

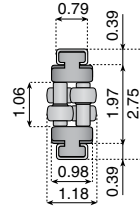
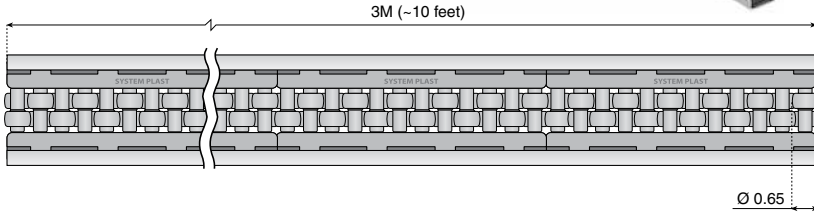
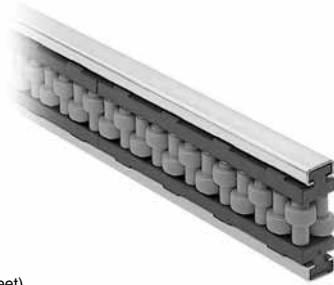

Material: Stainless steel channels. Polyamide straps, acetal rollers and pins, nickel plated brass spacers, stainless steel screws.

Part Number	Length (feet)
16152	3M (~10 ft.)

13833

Roller Module Clamp
Stainless steel clamp for roller modules.

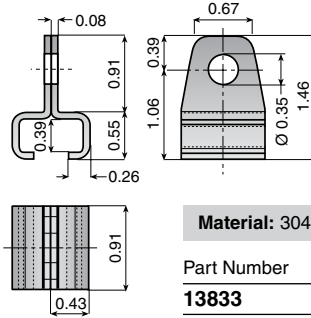

Material: 304 stainless steel.

Part Number
13833

33955

Adjusting Rod

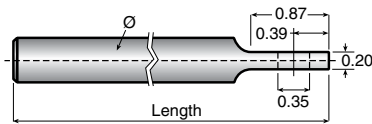

Material: 303 stainless steel.

Part Number	Length (in.)	Ø (in.)
33955	7	1/2

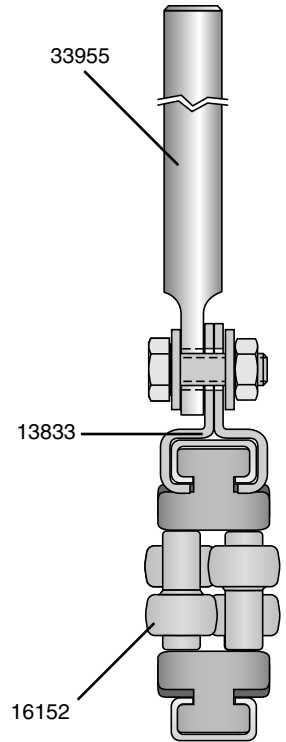

Bead and Roller Guides

684 BeadWall

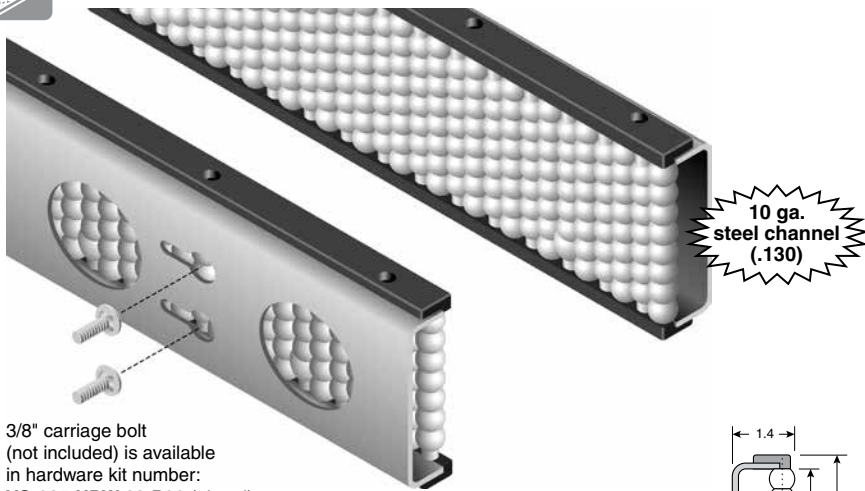

684

BeadWall

Low friction guiding surface with high density bead pattern. Excellent for combiner or accumulation areas. Operating temperature range: -4°F to +170°F.

Material: 10 ga. steel channel, polyamide pin rails, stainless steel pins, acetal beads.

Stainless Channel	Plated Channel	Length (ft.)	Height (in.)
VG-684-SS-2-02	VG-684-PL-2-02	2	2
VG-684-SS-2-03	VG-684-PL-2-03	3	2
VG-684-SS-2-04	VG-684-PL-2-04	4	2
VG-684-SS-2-05	VG-684-PL-2-05	5	2
VG-684-SS-2-06	VG-684-PL-2-06	6	2
VG-684-SS-2-07	VG-684-PL-2-07	7	2
VG-684-SS-2-08	VG-684-PL-2-08	8	2
VG-684-SS-2-10	VG-684-PL-2-10	10	2

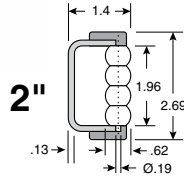

VG-684-SS-3-02	VG-684-PL-3-02	2	3
VG-684-SS-3-03	VG-684-PL-3-03	3	3
VG-684-SS-3-04	VG-684-PL-3-04	4	3
VG-684-SS-3-05	VG-684-PL-3-05	5	3
VG-684-SS-3-06	VG-684-PL-3-06	6	3
VG-684-SS-3-07	VG-684-PL-3-07	7	3
VG-684-SS-3-08	VG-684-PL-3-08	8	3
VG-684-SS-3-10	VG-684-PL-3-10	10	3

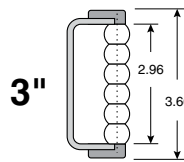

VG-684-SS-4-02	VG-684-PL-4-02	2	4
VG-684-SS-4-03	VG-684-PL-4-03	3	4
VG-684-SS-4-04	VG-684-PL-4-04	4	4
VG-684-SS-4-05	VG-684-PL-4-05	5	4
VG-684-SS-4-06	VG-684-PL-4-06	6	4
VG-684-SS-4-07	VG-684-PL-4-07	7	4
VG-684-SS-4-08	VG-684-PL-4-08	8	4
VG-684-SS-4-10	VG-684-PL-4-10	10	4

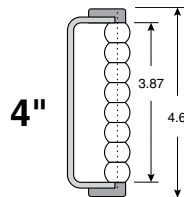

VG-684-SS-6-02	VG-684-PL-6-02	2	6
VG-684-SS-6-03	VG-684-PL-6-03	3	6
VG-684-SS-6-04	VG-684-PL-6-04	4	6
VG-684-SS-6-05	VG-684-PL-6-05	5	6
VG-684-SS-6-06	VG-684-PL-6-06	6	6
VG-684-SS-6-07	VG-684-PL-6-07	7	6
VG-684-SS-6-08	VG-684-PL-6-08	8	6
VG-684-SS-6-10	VG-684-PL-6-10	10	6

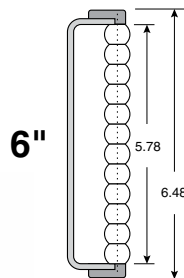

Bead and Roller Guides

VG-684-SS-2
VG-684-PL-2

VG-684-SS-3
VG-684-PL-3

VG-684-SS-4
VG-684-PL-4

VG-684-SS-6
VG-684-PL-6

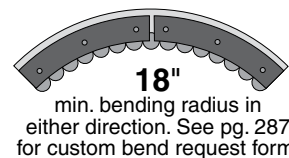
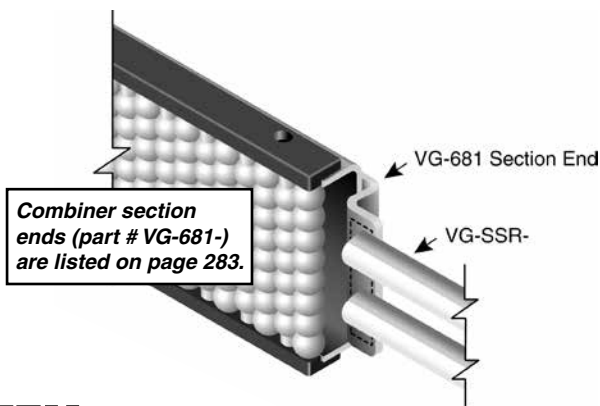
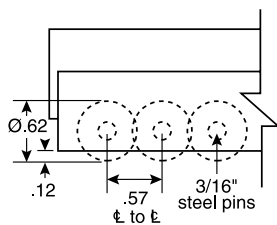
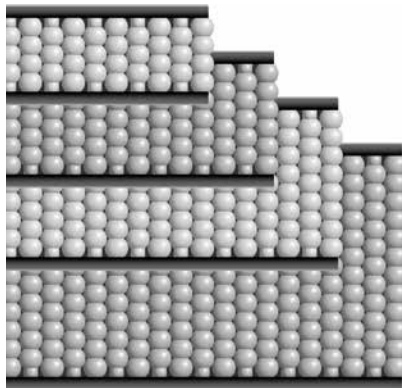

SYSTEM PLAST™

©2015 Regal-Beloit Corporation, All Rights Reserved.

685 Heavy Duty BeadWall



685

Heavy Duty BeadWall

Low friction guiding surface with high density bead pattern. Larger bead on larger pins accommodate larger load capacities. Excellent for combiner or accumulation areas. Operating temperature range: -4°F to +170°F.

Material: 10 ga. steel channel, polyamide pin rails, stainless steel pins, acetal beads.

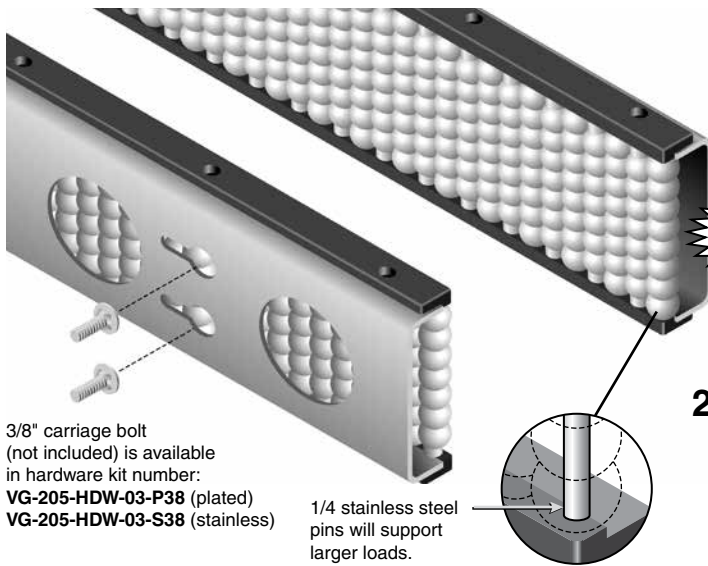

3/8" carriage bolt (not included) is available in hardware kit number:
VG-205-HDW-03-P38 (plated)
VG-205-HDW-03-S38 (stainless)

1/4 stainless steel pins will support larger loads.

10 ga. steel channel (.130)

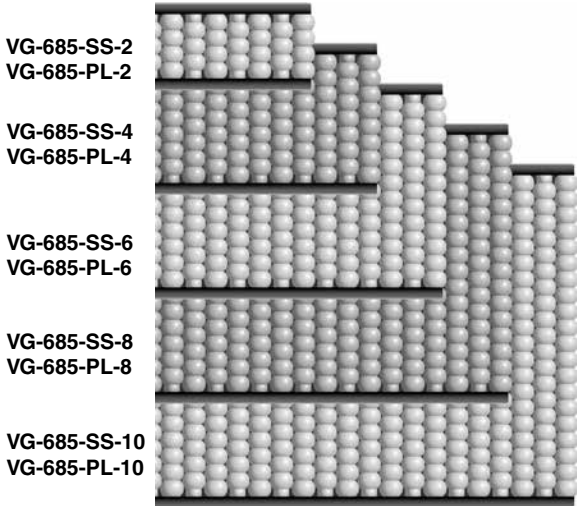
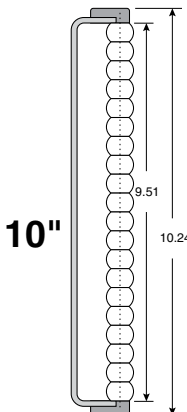
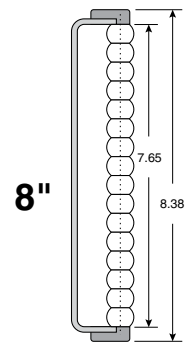
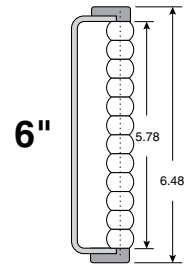
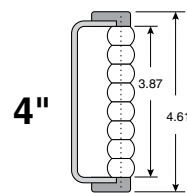
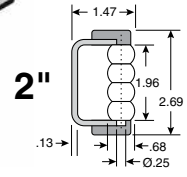

VG-685-SS-2
VG-685-PL-2

VG-685-SS-4
VG-685-PL-4

VG-685-SS-6
VG-685-PL-6

VG-685-SS-8
VG-685-PL-8

VG-685-SS-10
VG-685-PL-10

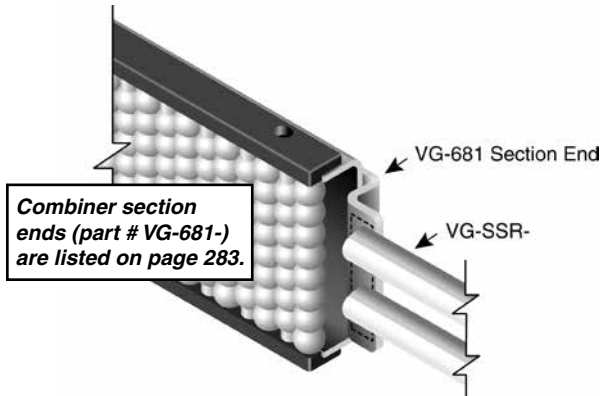
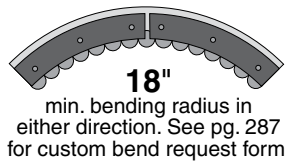
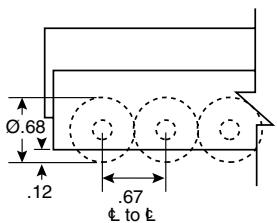

Stainless Channel	Plated Channel	Length (ft.)	Height (in.)
VG-685-SS-2-02	VG-685-PL-2-02	2	2
VG-685-SS-2-03	VG-685-PL-2-03	3	2
VG-685-SS-2-04	VG-685-PL-2-04	4	2
VG-685-SS-2-05	VG-685-PL-2-05	5	2
VG-685-SS-2-06	-	6	2
VG-685-SS-2-07	VG-685-PL-2-07	7	2
VG-685-SS-2-08	VG-685-PL-2-08	8	2
VG-685-SS-2-10	VG-685-PL-2-10	10	2

VG-685-SS-4-02	VG-685-PL-4-02	2	4
VG-685-SS-4-03	VG-685-PL-4-03	3	4
VG-685-SS-4-04	VG-685-PL-4-04	4	4
VG-685-SS-4-05	VG-685-PL-4-05	5	4
VG-685-SS-4-06	VG-685-PL-4-06	6	4
VG-685-SS-4-07	VG-685-PL-4-07	7	4
VG-685-SS-4-08	VG-685-PL-4-08	8	4
VG-685-SS-4-10	VG-685-PL-4-10	10	4

VG-685-SS-6-02	VG-685-PL-6-02	2	6
VG-685-SS-6-03	VG-685-PL-6-03	3	6
VG-685-SS-6-04	VG-685-PL-6-04	4	6
VG-685-SS-6-05	VG-685-PL-6-05	5	6
VG-685-SS-6-06	VG-685-PL-6-06	6	6
VG-685-SS-6-07	VG-685-PL-6-07	7	6
VG-685-SS-6-08	VG-685-PL-6-08	8	6
VG-685-SS-6-10	VG-685-PL-6-10	10	6

VG-685-SS-8-02	VG-685-PL-8-02	2	8
VG-685-SS-8-03	VG-685-PL-8-03	3	8
VG-685-SS-8-04	VG-685-PL-8-04	4	8
VG-685-SS-8-05	VG-685-PL-8-05	5	8
VG-685-SS-8-07	VG-685-PL-8-07	7	8
VG-685-SS-8-08	-	8	8
VG-685-SS-8-10	VG-685-PL-8-10	10	8

VG-685-SS-10-02	VG-685-PL-10-02	2	10
VG-685-SS-10-03	VG-685-PL-10-03	3	10
VG-685-SS-10-04	VG-685-PL-10-04	4	10
VG-685-SS-10-05	VG-685-PL-10-05	5	10
VG-685-SS-10-06	VG-685-PL-10-06	6	10
VG-685-SS-10-08	VG-685-PL-10-08	8	10
VG-685-SS-10-10	VG-685-PL-10-10	10	10

Bead and Roller Guides

682 Roller Combiner

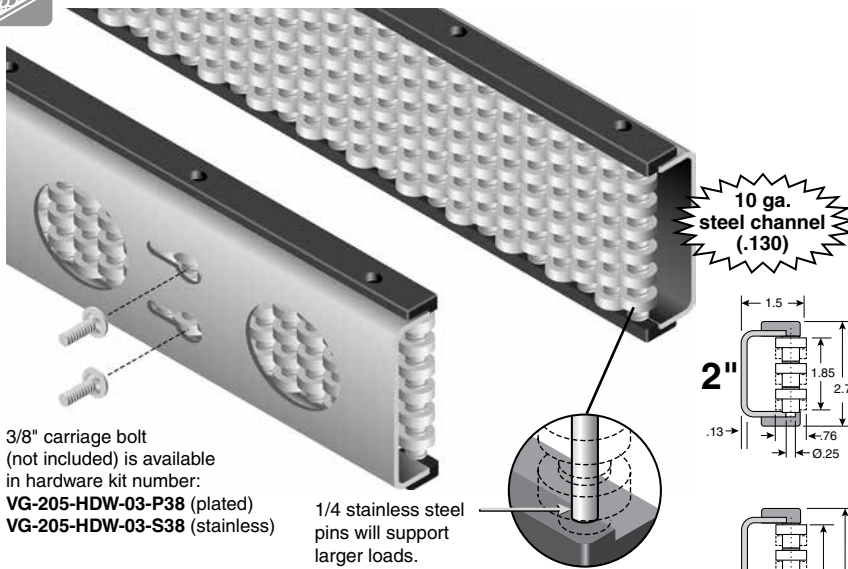

3/8" carriage bolt (not included) is available in hardware kit number:
 VG-205-HDW-03-P38 (plated)
 VG-205-HDW-03-S38 (stainless)

1/4 stainless steel pins will support larger loads.

10 ga. steel channel (.130)

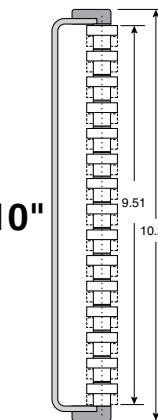
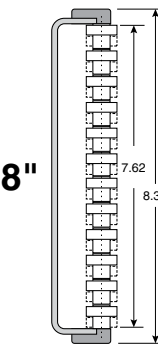
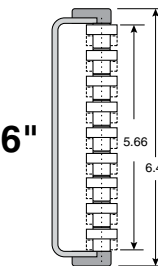
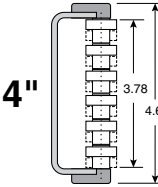
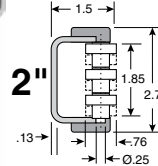

682

Roller Combiner

Low friction guiding surface. Excellent for combiner or accumulation areas.
 Operating temperature range: -4°F to +170°F.

Material: 10 ga. steel channel, polyamide pin rails, stainless steel pins, acetal rollers.

Stainless Channel	Plated Channel	Length (ft.)	Height (in.)
VG-682-SS-2-2	VG-682-PL-2-2	2	2
VG-682-SS-2-3	VG-682-PL-2-3	3	2
VG-682-SS-2-4	VG-682-PL-2-4	4	2
VG-682-SS-2-5	VG-682-PL-2-5	5	2
VG-682-SS-2-6	VG-682-PL-2-6	6	2
VG-682-SS-2-7	VG-682-PL-2-7	7	2
VG-682-SS-2-8	VG-682-PL-2-8	8	2
VG-682-SS-2-10	VG-682-PL-2-10	10	2
VG-682-SS-4-2	VG-682-PL-4-2	2	4
VG-682-SS-4-3	VG-682-PL-4-3	3	4
VG-682-SS-4-4	VG-682-PL-4-4	4	4
VG-682-SS-4-5	VG-682-PL-4-5	5	4
VG-682-SS-4-6	VG-682-PL-4-6	6	4
VG-682-SS-4-7	VG-682-PL-4-7	7	4
VG-682-SS-4-8	VG-682-PL-4-8	8	4
VG-682-SS-4-10	VG-682-PL-4-10	10	4
VG-682-SS-6-2	VG-682-PL-6-2	2	6
VG-682-SS-6-3	VG-682-PL-6-3	3	6
VG-682-SS-6-4	VG-682-PL-6-4	4	6
VG-682-SS-6-5	VG-682-PL-6-5	5	6
VG-682-SS-6-6	VG-682-PL-6-6	6	6
VG-682-SS-6-7	VG-682-PL-6-7	7	6
VG-682-SS-6-8	VG-682-PL-6-8	8	6
VG-682-SS-6-10	VG-682-PL-6-10	10	6
VG-682-SS-8-2	VG-682-PL-8-2	2	8
VG-682-SS-8-4	VG-682-PL-8-4	4	8
VG-682-SS-8-5	VG-682-PL-8-5	5	8
VG-682-SS-8-6	VG-682-PL-8-6	6	8
VG-682-SS-8-7	-	7	8
VG-682-SS-8-8	VG-682-PL-8-8	8	8
VG-682-SS-8-10	VG-682-PL-8-10	10	8
VG-682-SS-10-2	VG-682-PL-10-2	2	10
VG-682-SS-10-3	-	3	10
VG-682-SS-10-4	-	4	10
VG-682-SS-10-5	VG-682-PL-10-5	5	10
VG-682-SS-10-6	VG-682-PL-10-6	6	10
VG-682-SS-10-7	VG-682-PL-10-7	7	10
VG-682-SS-10-8	VG-682-PL-10-8	8	10
VG-682-SS-10-10	VG-682-PL-10-10	10	10

Bead and Roller Guides

VG-682-SS-2
 VG-682-PL-2

VG-682-SS-4
 VG-682-PL-4

VG-682-SS-6
 VG-682-PL-6

VG-682-SS-8
 VG-682-PL-8

VG-682-SS-10
 VG-682-PL-10

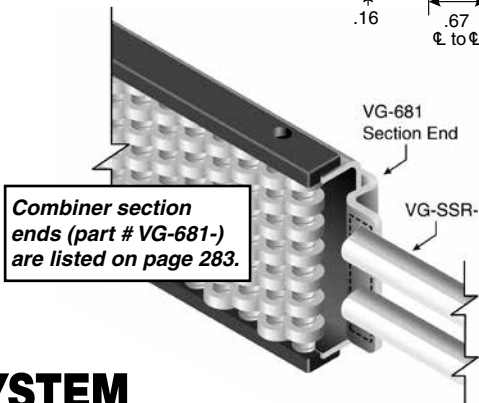
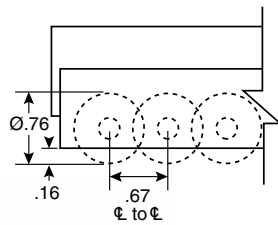
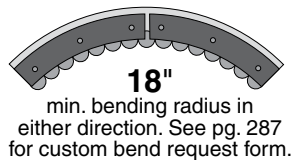

Combiner section ends (part # VG-681-) are listed on page 283.



681

Combiner Section Ends

Sold as pairs. Section Ends are bolted to the BeadWall or Roller Combiner frame. Fastening holes must be drilled on-site for assembly.

Material: 10 ga. stainless steel.

Part Number	Height (H)	Slot (A)	No. of Slots
VG-681-2	1.75	1.25	1
VG-681-3	2.75	.75	2
VG-681-4	3.75	1	2
VG-681-6	5.38	1.25	2

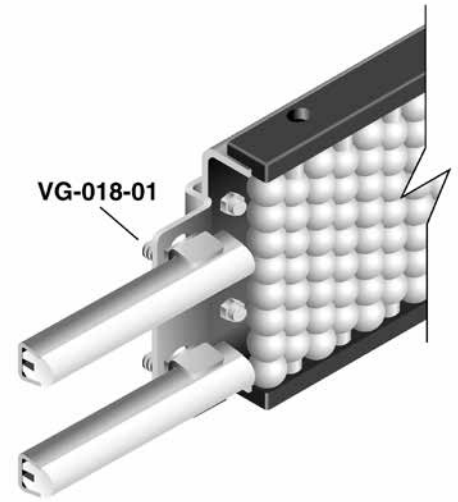
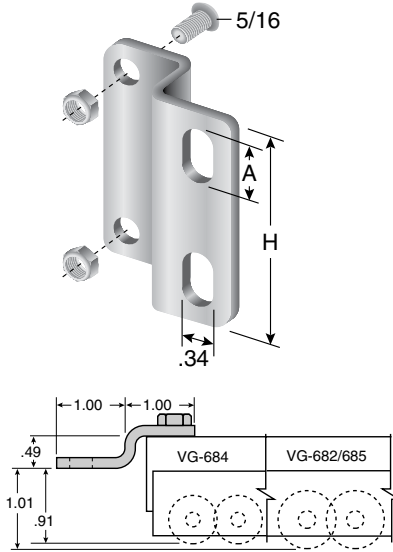

205-G

Braced Angle Bracket

Heavy duty base for VG-262 combiner bracket. 1/4" thick stainless steel. Built-in angled brace for maximum support of heavy loads.

Material: 304 stainless steel.

Part Number
VG-205-G-14-S

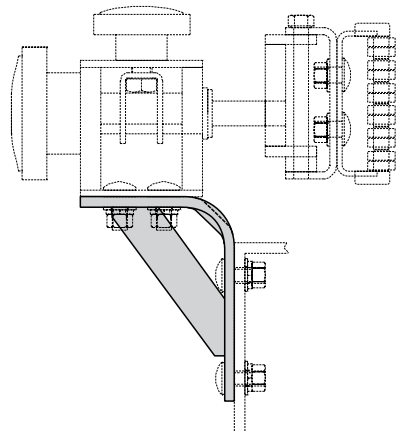
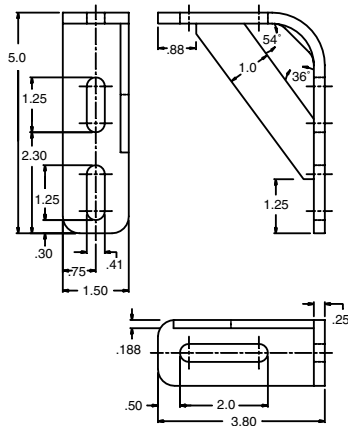

Bead and
Roller Guides



For Splicing...

117

BeadRail™ & SpeedRail™ Splice Kits

Used for joining two sections of aluminum channel BeadRail or SpeedRail.
Hardware included.

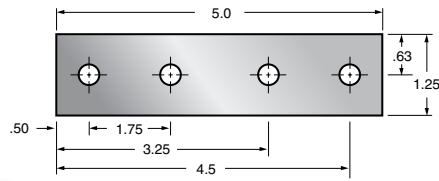

Material: Zinc plated steel.

Part Number	Compatibility	Fastener
VG-117-50125	1-1/2" Alum. Bead Rail (pg 275)	carriage bolt
VG-117-H50125	3" Alum. Bead Rail (pg 275)	hex head bolt
VG-117-T50125	Speed Rail (pg 269)	T-bolt (stainless)

For Slot Covering...

687BSC

Material: Flexible PVC.

Bolt Slot Cover

Helps prevent build-up of unwanted materials in the channel bolt slot.

Part Number	Length (ft.)
VG-687BSC-25	25
VG-687BSC-50	50



For Corner Rod Attachment...

040

BeadRail™ & SpeedRail™ Corner Clip

Allows Valu Guide jointed adjusting rods to be installed with articulation on the same plane as BeadRail, SpeedRail, or standard adjusting rods to be installed parallel.

Material: Stainless steel.

Part Number
VG-040-01

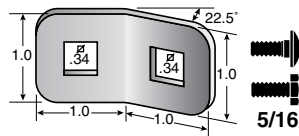

VG-212 or VG-232 Stainless Steel Rods

For Lane Dividers...

687LDB

Lane Divider Bracket

Mounts to 687 series or 688 series lane dividers using provided T-Head bolts. Allows for easy attachment to any lane divider support using a 5/16 or M8 fastener.

Material: Stainless steel.

Part Number
VG-687LDB-516
VG-687LDB-M8

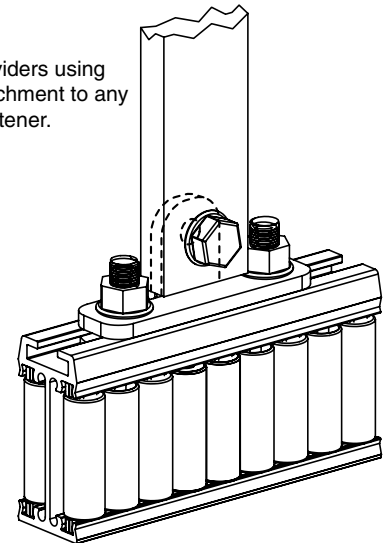
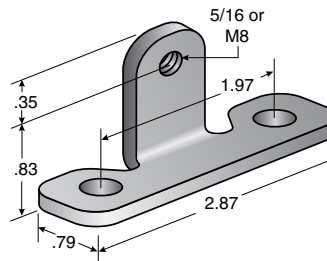

For Steel Channels...

HW684

BeadRail™ Washer

Washer required for applications using a tapped adjusting rod.

Material: Stainless steel.

Part Number
HW684WSHS

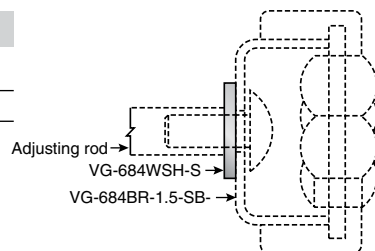
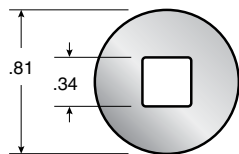

For Fastening...

1568

T-head bolts

Included with the SpeedRail and SpeedRoll combiners.

Material: Stainless steel.

Part Number	L
VG-1568-01	.64
VG-1568-02	.76
VG-1568-03	1.01
VG-1568-04	1.26

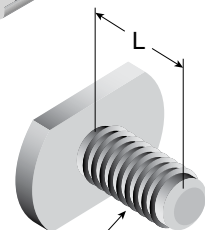
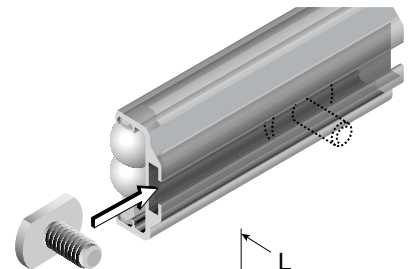

5/16-18

Side Plows and Nose Plows

Side Plow for SpeedRail SB™ and SpeedRoll™

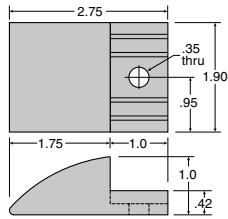

Material: Machined Nolu-S with stainless steel fastener.

Part Number
VG-687SP-1.4

Side Plow for 2-Strand SpeedRail SB™ and SpeedRoll™

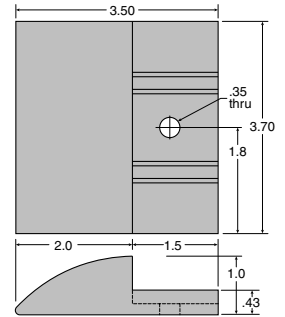
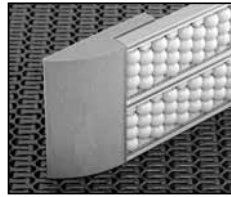

Material: Machined Nolu-S with stainless steel fastener.

Part Number
VG-687SP-3.3

Side Plow for SpeedRail™



Material: Machined Nolu-S with stainless steel fastener.

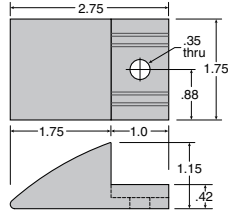

Part Number
VG-686SP-1.25

Side Plow for 2-Strand SpeedRail™

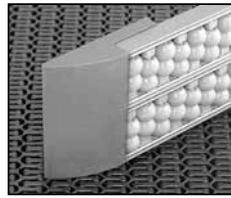

Material: Machined Nolu-S with stainless steel fastener.

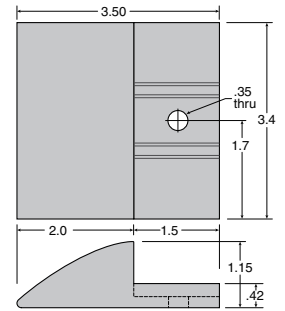

Part Number
VG-686SP-3.0

Bead and Roller Guides

Nose Plow for SpeedRail SB™ and SpeedRoll™ lane divider



Material: Machined Nolu-S with stainless steel fastener.

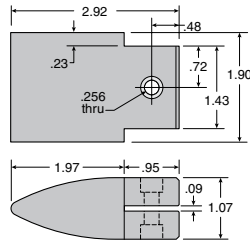

Part Number
VG-687NP-1.4



Technical Information for BeadWall, BeadRail, and Roller Combiner

Combiner frame hole patterns and recommended VG-205 mounting brackets

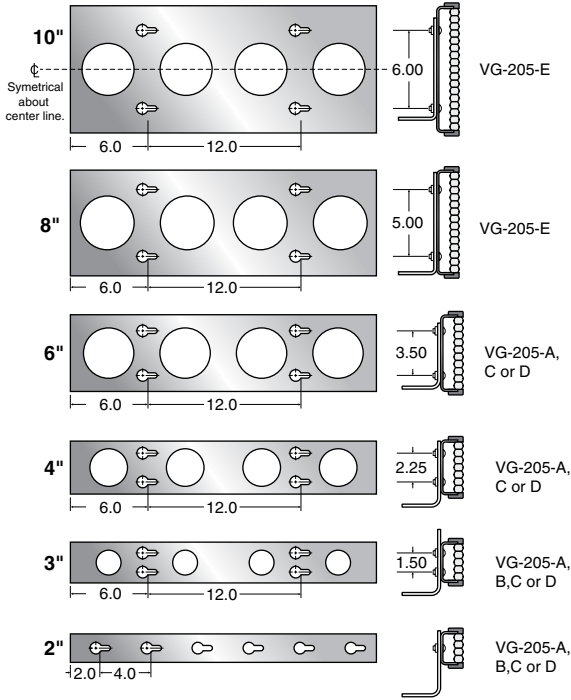

VG-205 series L brackets can be bolted to the backside of the channel frame for mounting. See pages 321-322 for more information.

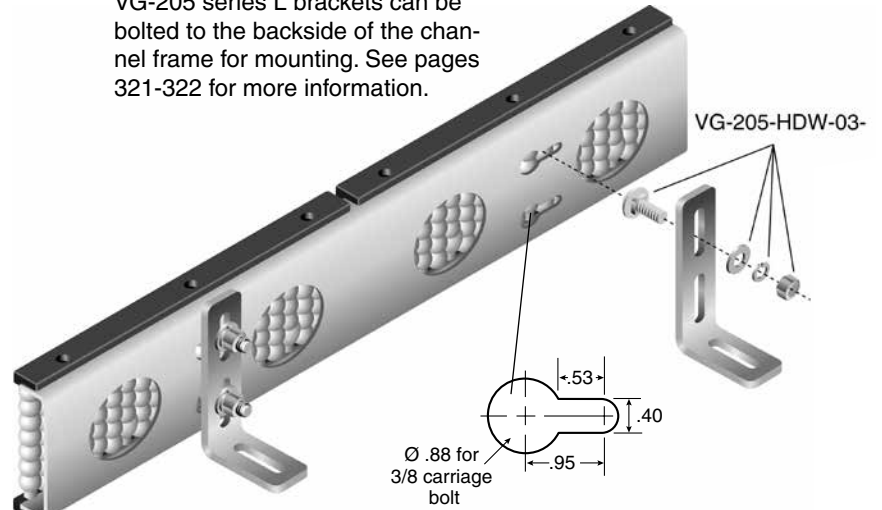

Bead and Roller Guides

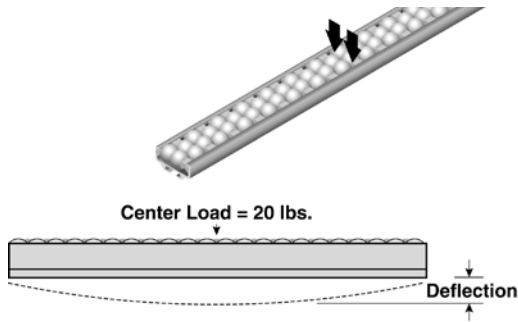

Aluminum Channel Bead Guides

Part Number	Maximum Deflection		Moment of Inertia
	24 Length	36 Length	
VG-686A-1.25	.007	.024	.020
VG-686A-3.0	.005	.016	.030
VG-687-1.4	.010	.034	.014
VG-687-3.3	.006	.019	.025
VG-688-1.4	.010	.034	.014
VG-688-3.3	.006	.019	.025
VG-684BR-1.5-AB	.009	.031	.016
VG-684BR-3-AB	.007	.024	.020

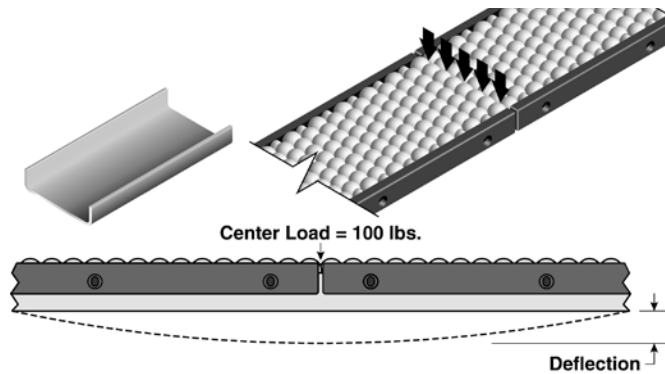

Steel Channel Bead Guides

10 gauge Channel Height	Maximum Deflection		Moment of Inertia
	24 Length	36 Length	
2 inches	.005	.017	.048
3 inches	.005	.016	.053
4 inches	.004	.015	.057
6 inches	.004	.014	.061
8 inches	.004	.013	.064
10 inches	.004	.013	.066

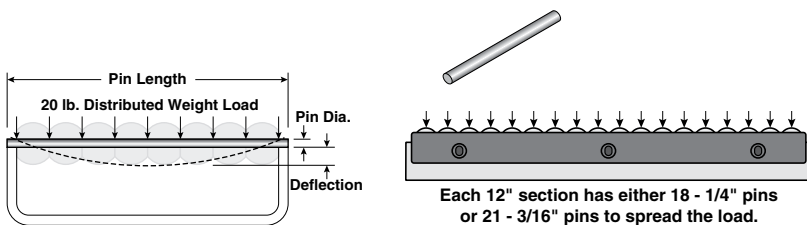

Single Metal Pins

Pin Length in Inches	Maximum Pin Deflection	
	3/16 dia.	1/4 dia.
2	.001	0
3	.004	n/a
4	.009	.003
6	.031	.01
8	n/a	.023
10	n/a	.045

Custom Bead Guide Bending Request



System Plast will be pleased to quote on custom bending of our bead guides to your special requirements. This page may be copied and used to send us your specifications. For assistance, please contact System Plast customer service:

phone: 866-765-8744 fax: 866-447-6587

Person Requesting Custom Information _____
 Company Name _____
 Address _____
 City _____ State _____ Zip _____
 Phone () _____ Fax () _____

Single Bends

If available, please include a detailed drawing of desired bend.

BASE PART NUMBER: _____ (example: VG-684-PI-6-)
 RADIUS OF BEND (R): _____ inches
 ANGLE OF BEND (D): _____ degrees
 QUANTITY: _____ pieces
 TYPE OF BEND: Inside Curve Outside Curve

Our manufacturing process typically requires the inclusion of 3 to 6 inch tangents on each end of the curve. There is no additional cost for this. If specific tangents are required, please indicate below.

TANGENT LENGTH (T1): _____ inches
 TANGENT LENGTH (T2): _____ inches

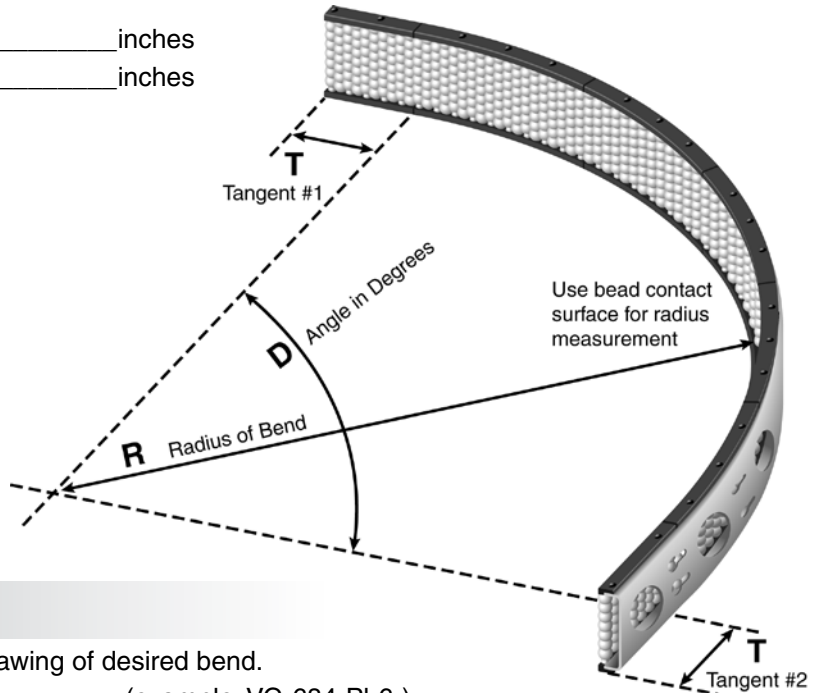
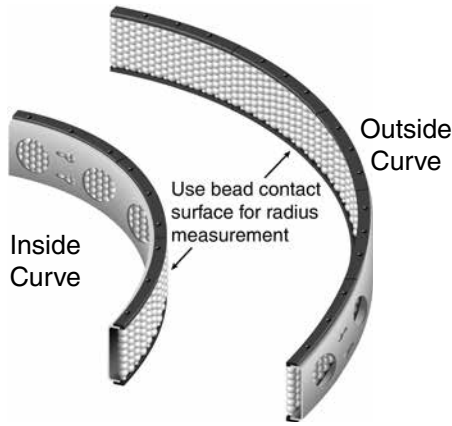

Bead and Roller Guides

S-Curve Bends

If available, please include a detailed drawing of desired bend.

BASE PART NUMBER: _____ (example: VG-684-PI-6-)
 RADIUS OF BEND (R1): _____ inches
 RADIUS OF BEND (R2): _____ inches
 ANGLE OF BEND (X): _____ degrees
 ANGLE OF BEND (Y): _____ degrees
 LENGTH (L1): _____ inches
 LENGTH (L2): _____ inches
 LENGTH (L3): _____ inches

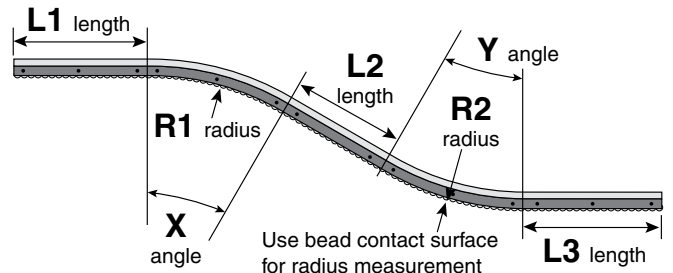

COMMENTS:

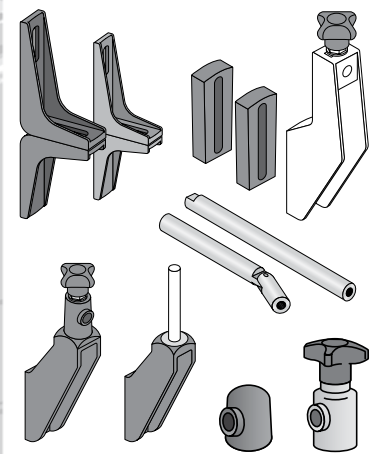
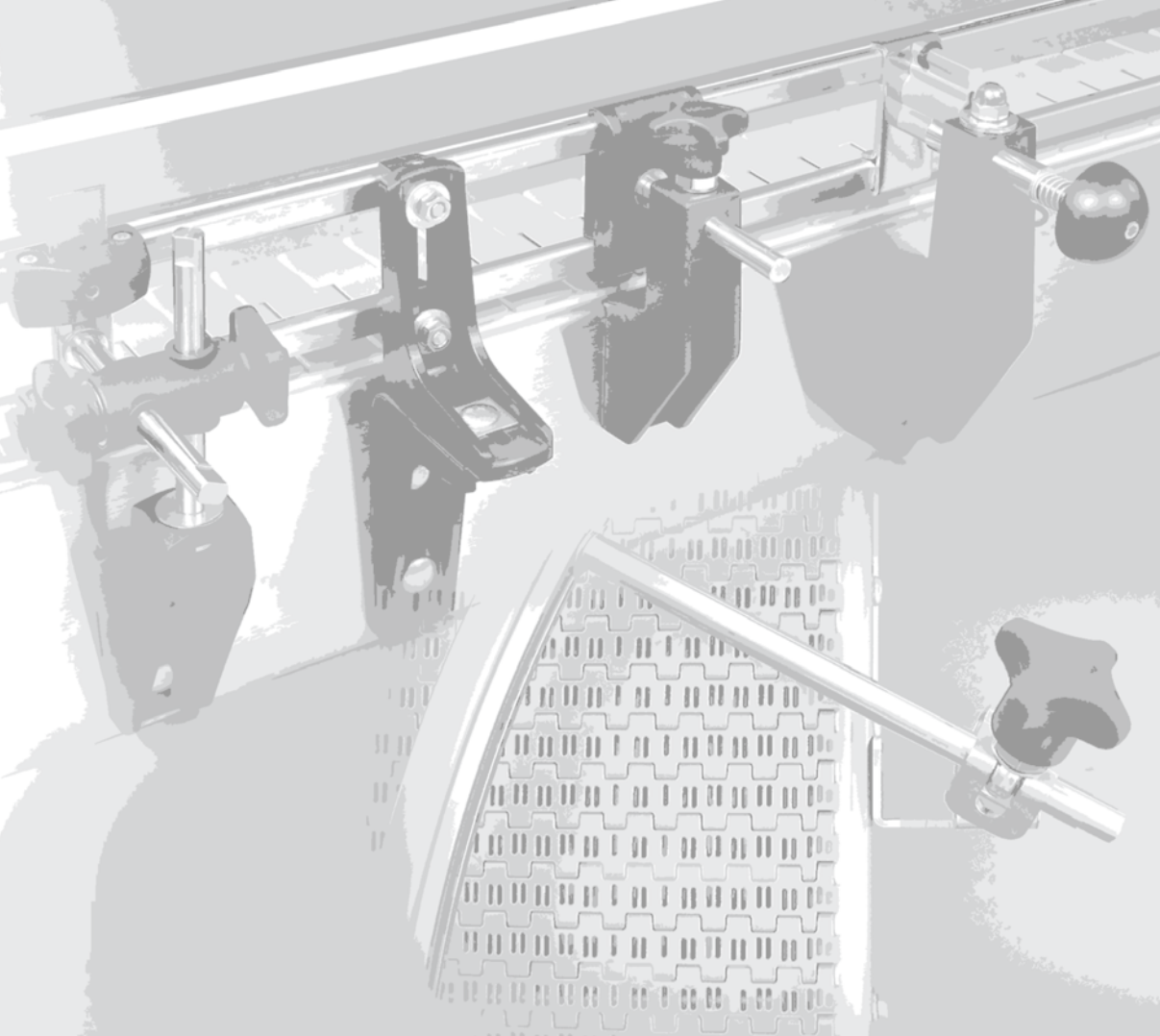

**Polyamide
Brackets Page 291**
 Standard duty Heavy duty
 Swivel caps Adjusting rods
 Angle brackets Knobs Spacers

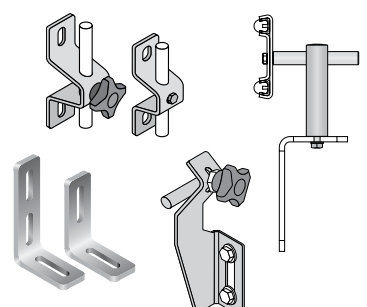

**Metal
Brackets Page 308**
 Side mount Post brackets
 Angle brackets Mounting bars

BRACKETS & POSITIONING COMPONENTS

Section 6

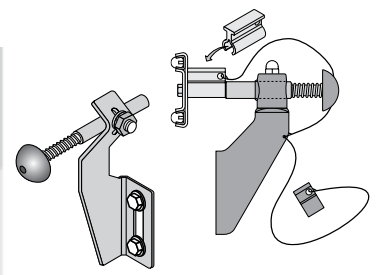
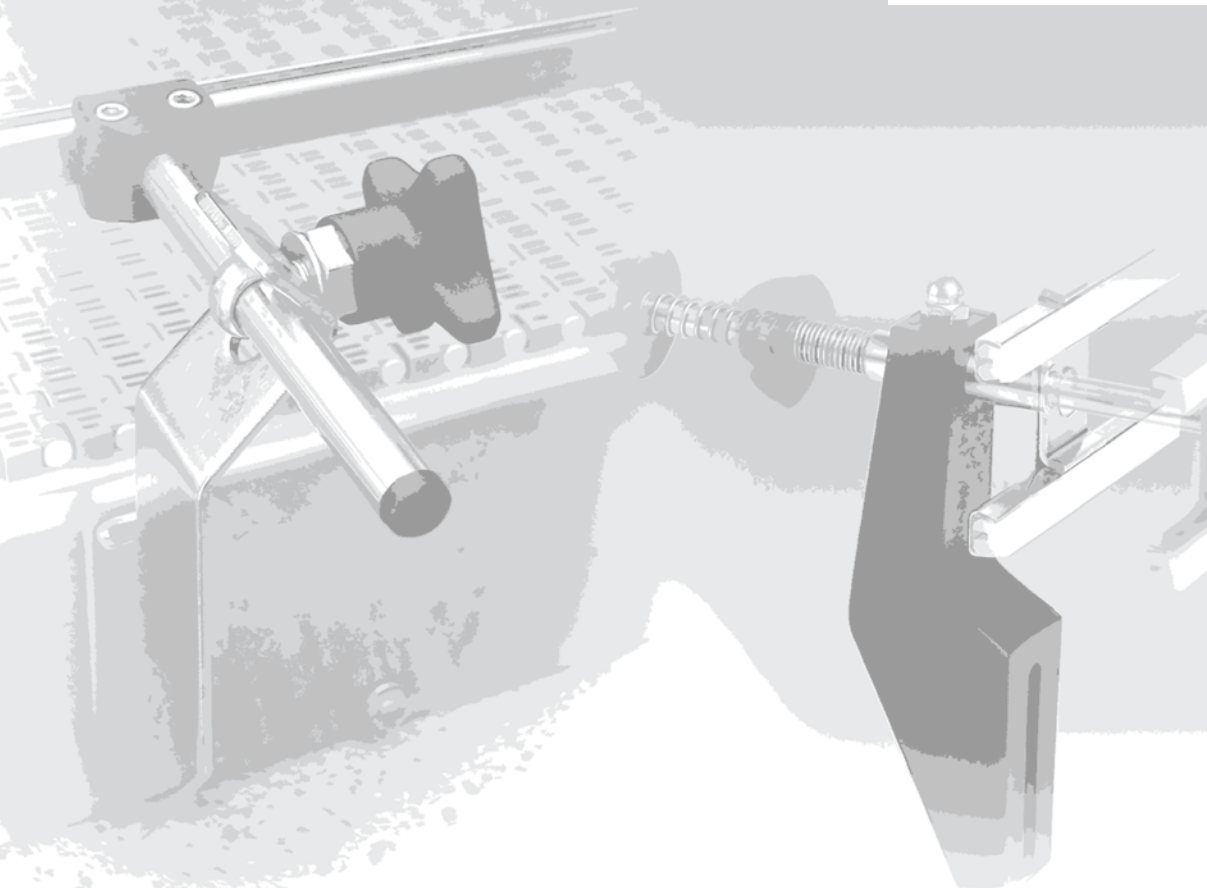

**SpeedSet Brackets
Page 298-303, 315-320**

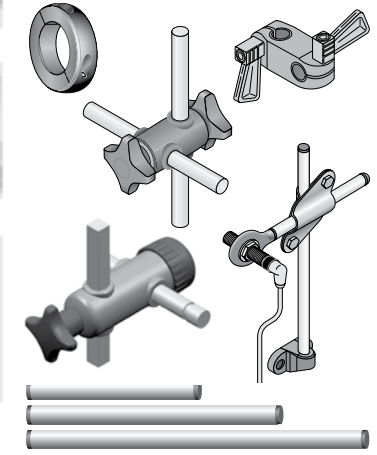

Positioning Page 327
 Cross blocks Shaft collars
 Accessory mounts Support rods

Valu Guide™ Brackets

The Ultimate in Adjustability and Cost Savings

Valu Guide brackets are part of a family of products that work together to make guide rail adjusting easy. A variety of bracket styles and materials combined with accessories such as spacers, knobs, and adjusting rods are designed for maximum versatility. Every bracket has been designed to meet the needs of the demanding environments in which they are used. From a simple fixed metal bracket to our newest Speed-Set bracket, you will find a solution to meet your application and cost requirements.



L Brackets

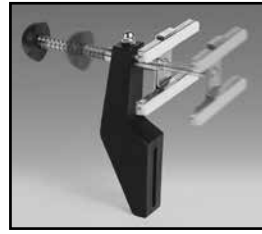

SpeedSet™ Brackets

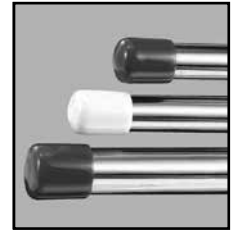

Adjusting Rods and Caps

Adjusting knobs eliminate the need for tools when repositioning guide rail.



Swivel caps are available in a variety of heights and materials for some bracket styles. Stacking rings can be used for additional height requirements.

All fittings and hardware are made from corrosion resistant materials. The eyelets provide excellent gripping strength on the adjusting rods without marring the rod which means longer, trouble free life.

A complete line of adjusting rods is available for all Valu Guide bracket styles.

The VG-210 bracket shown can also be configured with the adjusting knob on the side of the bracket body.

Some molded brackets come with a lip which allows for single bolt mounting and helps to square the bracket with the conveyor.

Spacers can be used to offset the bracket from the mounting location.

Valu Guide brackets are manufactured from engineered plastics designed to offer the optimum in strength and resistance to corrosion.

Mounting slots instead of holes allow for bracket adjustment after initial installation.



VG-210 shown see page 294.

Guide Rail Brackets



Guide Rail Brackets

Valu Guide brackets offer the ultimate in guide rail adjustability. Choose from bolt tightening assemblies or hand knob tightening assemblies that eliminate the need for tools. Use Valu Guide spacers, adapters, and stacking rings for even greater bracket versatility. Valu Guide also offers a full line of adjusting rods designed for use with each bracket.



Quality products start with quality materials.

Polyamide

The characteristics of **polyamide (PA)** resin make it an excellent material choice for molded component parts that must stand up to demanding industrial applications. Valu Guide uses reinforced polyamide (nylon) to provide our customers with products that are dimensionally stable, have very high mechanical strength, high rigidity and toughness, resistance to heat deformation, and satisfactory chemical resistance. Continuous operating temperature range: -4°F to +190°F. Withstands intermittent temperatures up to 215°F.

Polypropylene

For applications that require even greater resistance to chemicals, selected Valu Guide parts are also available in reinforced **polypropylene (PP)**. Continuous operating temperature range: -40°F to +190°F. Withstands intermittent temperatures up to 215°.

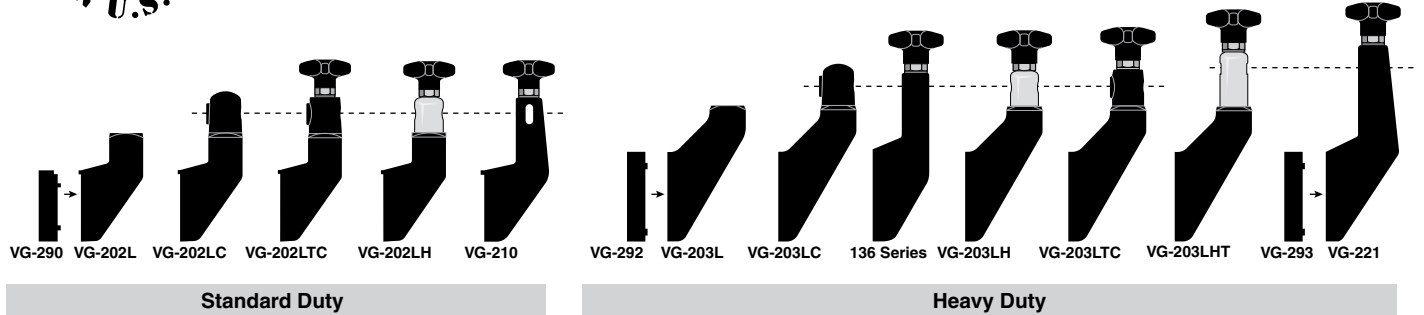

Standard Duty

Heavy Duty

221

Heavy Duty Guide Rail Bracket

Longer slots allow mounting bolt centers up to 3 inches.

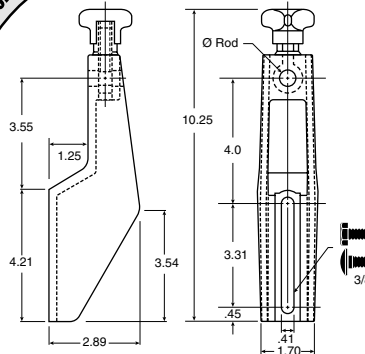
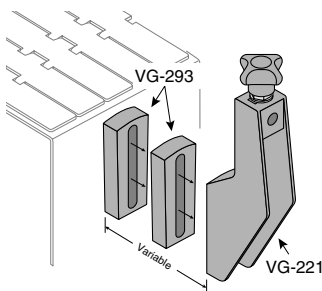

Material: Polyamide (PA) or polypropylene (PP) bracket body and knob. Nickel plated brass knob bushing. Stainless steel hardware.

Part Number	Ø Rod	Material
VG-221-12	1/2	PA
VG-221-58	5/8	PA
VG-221-34	3/4	PA
VG-221PP-12	1/2	PP
VG-221PP-58	5/8	PP
VG-221PP-34	3/4	PP

Brackets & Positioning

136 series

Mid-Size Guide Rail Bracket

Sized for medium to large containers.

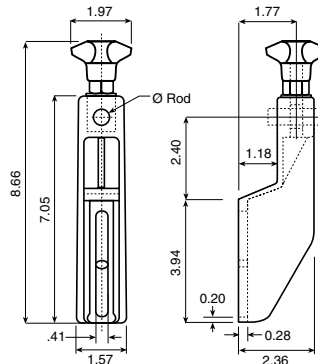
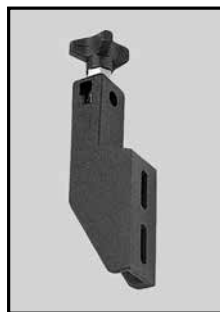

Material: Polyamide bracket body and knob. Nickel plated brass knob bushing. Stainless steel hardware.

Part Number	Ø Rod
13641	1/2
13648	5/8

Guide Rail Brackets



203L

Bracket Body

For use with threaded adjusting rod and cross blocks where vertical and horizontal adjustment is needed.

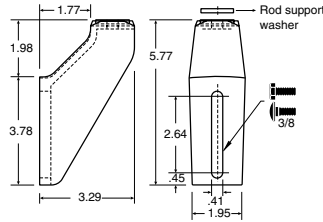
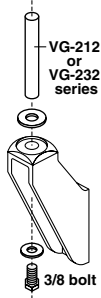

Rod not included.

Material: Polyamide bracket body.
Stainless steel washer.

Part Number

VG-203L

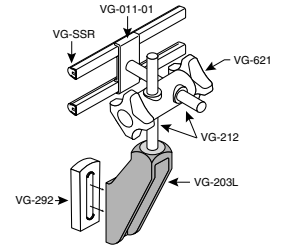

203LTC

Swivel Bracket

Support for guide rails where both horizontal and swivel adjustment is required.

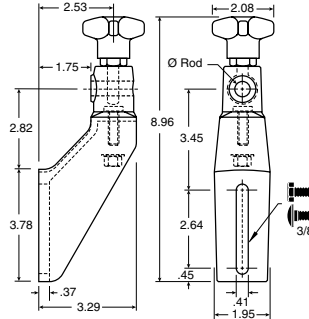

Material: Polyamide bracket body, transition cap and knob. Stainless steel hardware.

Part Number

Ø Rod

VG-203LTC-12 1/2

VG-203LTC-58 5/8

VG-203LTC-34 3/4



203LHS

Swivel Bracket

Support for guide rails where both horizontal and swivel adjustment is required.

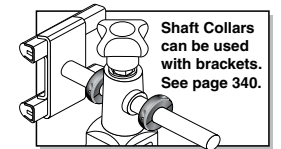
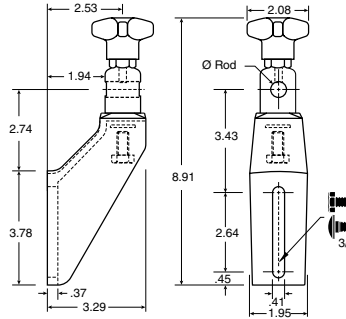

Shaft Collars can be used with brackets. See page 340.

Material: Polyamide bracket body and knob. Stainless steel swivel cap and hardware.

Part Number

Ø Rod

VG-203LHS-12 1/2

VG-203LHS-58 5/8

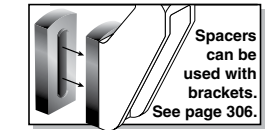

Spacers can be used with brackets. See page 306.

203LHTS

Swivel Bracket

Support for guide rails where both horizontal and swivel adjustment is required.

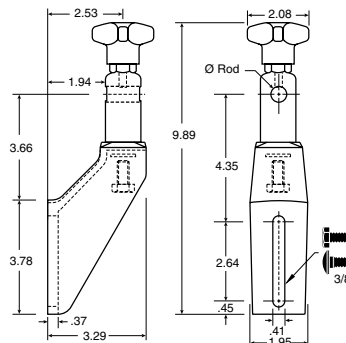
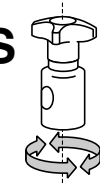

Material: Polyamide bracket body and knob. Stainless steel swivel cap and hardware.

Part Number

Ø Rod

VG-203LHTS-12 1/2

VG-203LHTS-58 5/8

203LC

Swivel Bracket

Support for guide rails where both horizontal and swivel adjustment is required. VG-CTOP swivel cap only is on page 295.

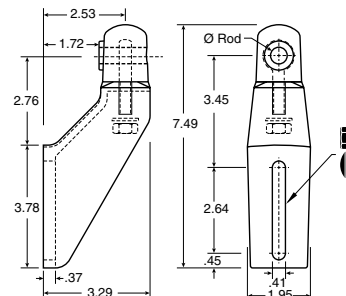
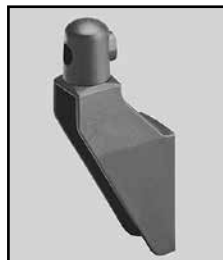
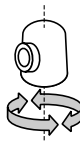

Material: Polyamide bracket body, cap and knob. Stainless steel hardware.

Part Number

Ø Rod

VG-203LC-12 1/2

VG-203LC-58 5/8

SYSTEM PLAST™

©2015 Regal-Beloit Corporation, All Rights Reserved.



203HS

Swivel Cap Assembly

Support for guide rails where swivel adjustment is required. For use on VG-203L body.

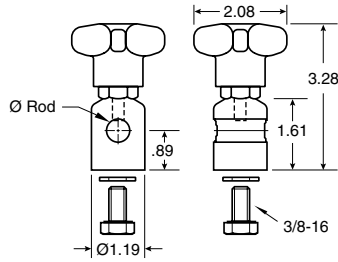

Material: Stainless steel cap and hardware. Polyamide knob.

Part Number	Ø Rod
VG-203HS-12	1/2
VG-203HS-58	5/8

203HTS

Swivel Cap Assembly

Support for guide rails where swivel adjustment is required. For use on VG-203L body.

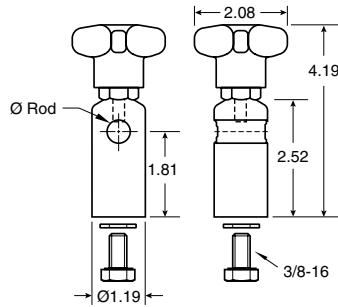

Material: Stainless steel cap and hardware. Polyamide knob.

Part Number	Ø Rod
VG-203HTS-12	1/2
VG-203HTS-58	5/8

1378

Swivel Cap Assembly

Support for guide rails where swivel adjustment is required.

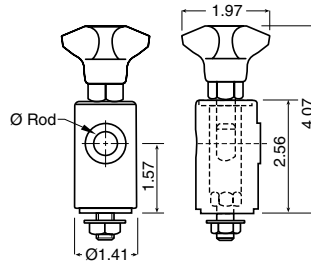

Material: Polyamide cap and knob. Stainless steel eyelet and nut.

Part Number	Ø Rod
13781V	1/2
13783V	5/8

203TC

Transition Cap Assembly

Support for guide rails where swivel adjustment is required. For use on VG-203L body.

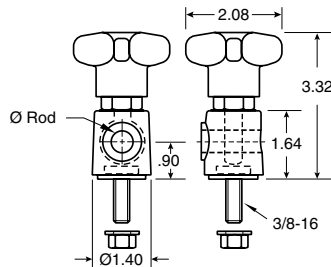
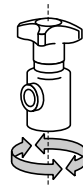

Material: Polyamide cap and knob. Stainless steel eyelet and nut.

Part Number	Ø Rod
VG-203TC-12	1/2
VG-203TC-58	5/8
VG-203TC-34	3/4

13129V

Swivel Cap Assembly

Support for guide rails where swivel adjustment is required.

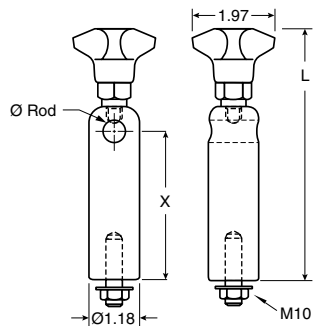

Material: Stainless steel cap and hardware. Polyamide knob.

Part Number	X	L	Ø Rod
13130V	5.12	5.71	1/2
13129V	3.54	4.21	5/8

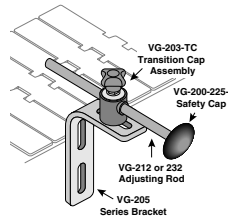
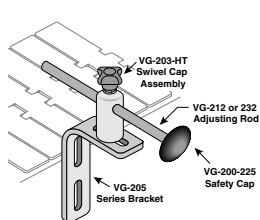

Note: When stacking rings are used, rod center line changes and a longer bolt is required.

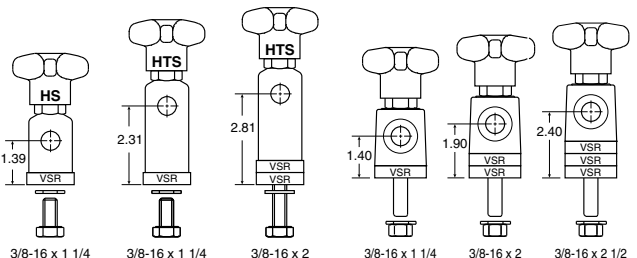

Brackets & Positioning

Guide Rail Brackets

210

Guide Rail Bracket

Guide rail support where lateral adjustment is needed.

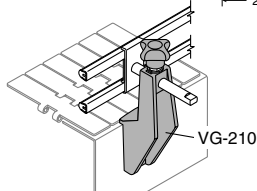
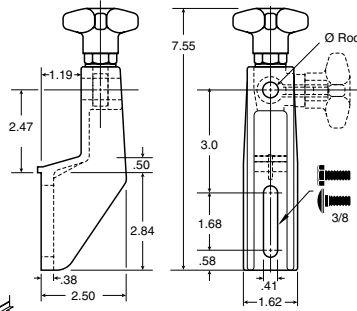
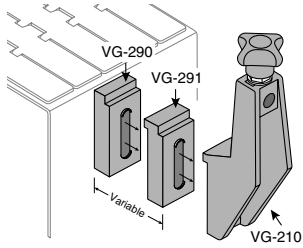

Material: Polyamide (PA) or polypropylene (PP) bracket body and knob. Nickel plated brass knob bushing. Stainless steel hardware.

Part Number	Ø Rod	Material
VG-210-12	1/2	PA
VG-210-58	5/8	PA
VG-210-34	3/4	PA
VG-210PP-12	1/2	PP
VG-210PP-58	5/8	PP
VG-210PP-34	3/4	PP

Brackets without positioning lip

VG-210F-12	1/2	PA
VG-210F-58	5/8	PA
VG-210F-34	3/4	PA
VG-210FPP-12	1/2	PP
VG-210FPP-58	5/8	PP
VG-210FPP-34	3/4	PP

202L

Bracket Body

For use with threaded adjusting rod and cross blocks where vertical and horizontal adjustment is needed.

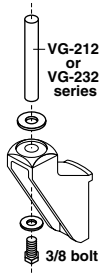

Rod not included.

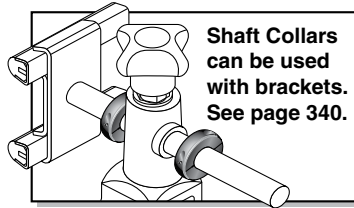
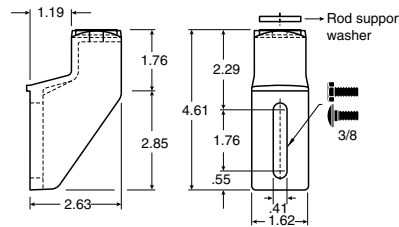

Shaft Collars can be used with brackets. See page 340.

Material: Polyamide bracket body. Stainless steel washer.

Part Number	Without positioning lip
VG-202L	VG-202FL

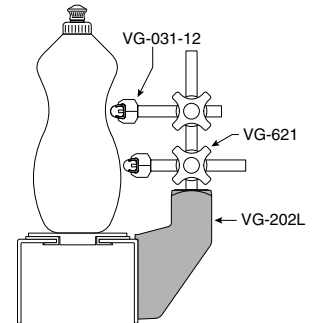

202LTC

Swivel Bracket

Support for guide rails where both horizontal and swivel adjustment is required.

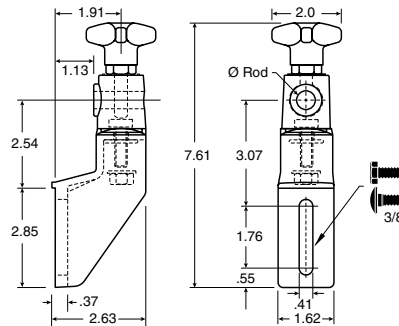

Material: Polyamide bracket body, transition cap and knob. Stainless steel hardware.

Part Number	Ø Rod
VG-202LTC-12	1/2
<i>Brackets without positioning lip</i>	
VG-202FLTC-12	1/2

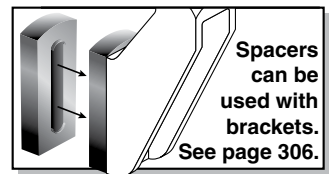

Spacers can be used with brackets. See page 306.

202LHS

Swivel Bracket

Support for guide rails where both horizontal and swivel adjustment is required.

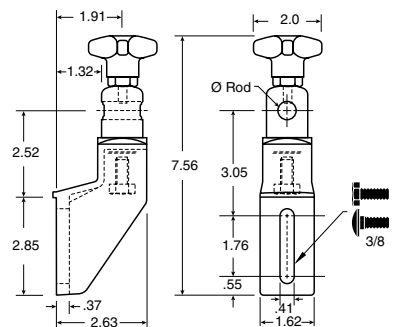

Material: Polyamide bracket body and knob. Stainless steel swivel cap and hardware.

Part Number	Ø Rod
VG-202LHS-12	1/2
<i>Brackets without positioning lip</i>	
VG-202FLHS-12	1/2

SYSTEM PLAST™

©2015 Regal-Beloit Corporation, All Rights Reserved.

Brackets & Positioning



202LC

Swivel Bracket
Support for guide rails where both horizontal and swivel adjustment is required.

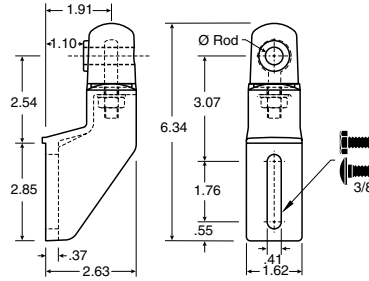
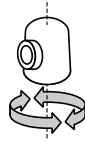

Material: Polyamide bracket body, cap and knob. Stainless steel hardware.

Part Number	Ø Rod
VG-202LC-12	1/2
<i>Brackets without positioning lip</i>	
VG-202FLC-12	1/2

202TC

Transition Cap Assembly
Support for guide rails where swivel adjustment is required. For use on VG-202L body.

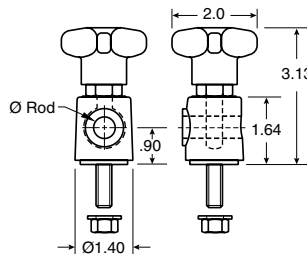
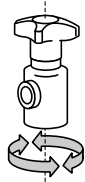

Material: Polyamide cap and knob. Stainless steel eyelet and nut.

Part Number	Ø Rod
VG-202TC-12	1/2

202HS

Swivel Cap Assembly
Support for guide rails where swivel adjustment is required. For use on VG-202L body.

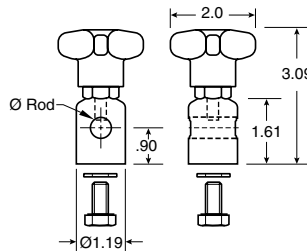
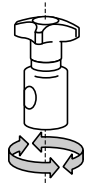

Material: Stainless steel cap and hardware. Polyamide knob.

Part Number	Ø Rod
VG-202HS-12	1/2

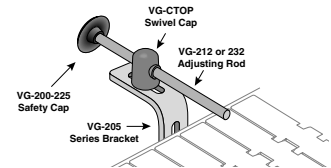

Brackets & Positioning

CTOP

Swivel Cap
Support for guide rails where swivel adjustment is required. For use on VG-202L and VG-203L bracket bodies or other mounting surfaces.

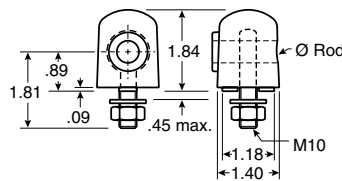

Material: Polyamide cap. Stainless steel eyelet and nut.

Part Number	Ø Rod
VG-CTOP-12	1/2
VG-CTOP-58	5/8

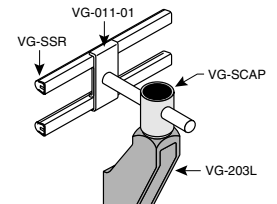

SCAP

Stainless Swivel Cap
Support for guide rails where swivel adjustment is required. For use on VG-202L and VG-203L bracket bodies or other mounting surfaces.

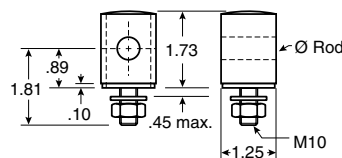

Material: Stainless steel cap eyelet and nut.

Part Number	Ø Rod
VG-SCAP-12	1/2
VG-SCAP-58	5/8

Adjusting Rods

212

1/2 Adjusting Rod

Connects to VG-011, VG-012, VG-016 and VG-018 style clips and clamps.

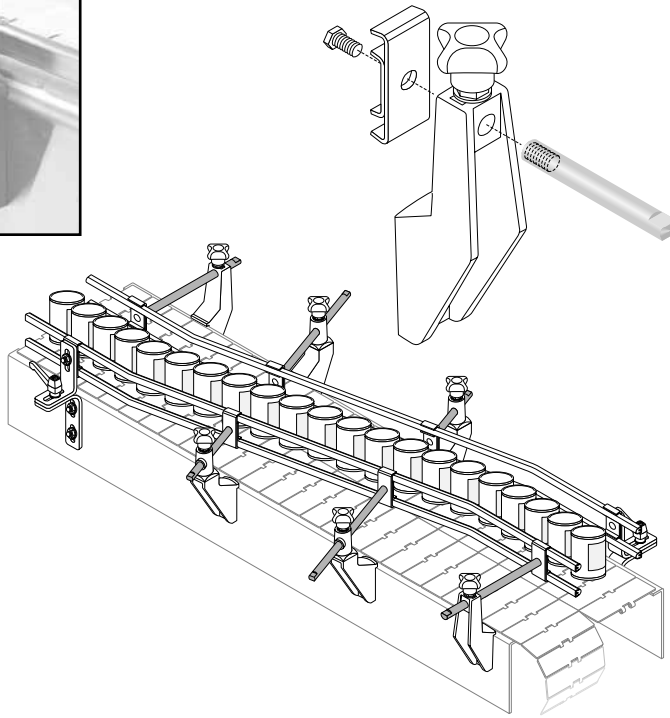
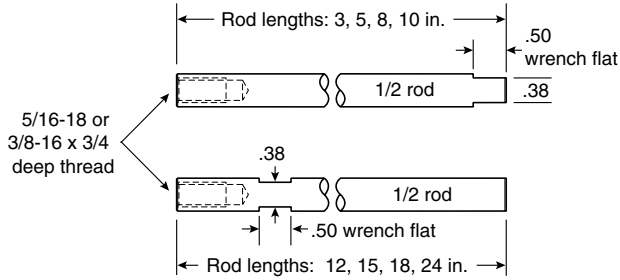

Material: Stainless steel.

Part Number	Length (in.)	Tapped Thread
VG-212-3-516	3	5/16-18
VG-212-3-38	3	3/8-16
VG-212-5-516	5	5/16-18
VG-212-5-38	5	3/8-16
VG-212-8-516	8	5/16-18
VG-212-8-38	8	3/8-16
VG-212-10-516	10	5/16-18
VG-212-10-38	10	3/8-16
VG-212-12-516	12	5/16-18
VG-212-12-38	12	3/8-16
VG-212-15-516	15	5/16-18
VG-212-15-38	15	3/8-16
VG-212-18-516	18	5/16-18
VG-212-18-38	18	3/8-16
VG-212-24-516	24	5/16-18
VG-212-24-38	24	3/8-16

Brackets & Positioning

232

5/8 Adjusting Rod

Connects to VG-011, VG-012, VG-016 and VG-018 style clips and clamps.

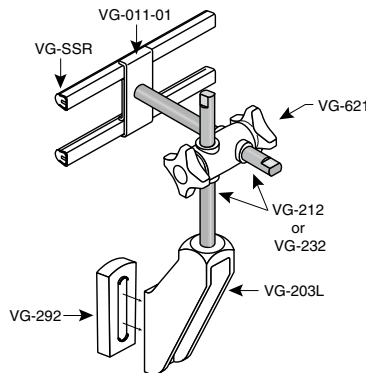
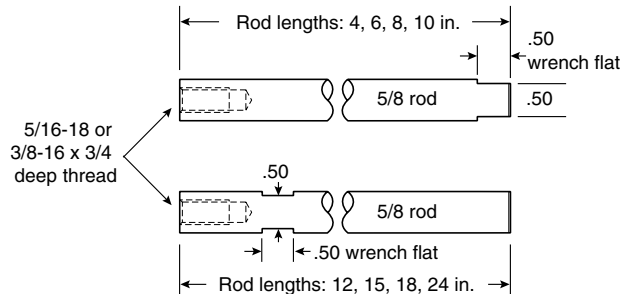

Material: Stainless steel.

Part Number	Length (in.)	Tapped Thread
VG-232-4-516	4	5/16-18
VG-232-4-38	4	3/8-16
VG-232-6-516	6	5/16-18
VG-232-6-38	6	3/8-16
VG-232-8-516	8	5/16-18
VG-232-8-38	8	3/8-16
VG-232-10-516	10	5/16-18
VG-232-10-38	10	3/8-16
VG-232-12-516	12	5/16-18
VG-232-12-38	12	3/8-16
VG-232-15-516	15	5/16-18
VG-232-15-38	15	3/8-16
VG-232-18-516	18	5/16-18
VG-232-18-38	18	3/8-16
VG-232-24-516	24	5/16-18
VG-232-24-38	24	3/8-16



212J, 232J

Jointed Adjusting Rods: Tapped

Guide rail that has been formed into curves or angles can easily be positioned with Valu Guide Jointed Adjusting Rods. When used with Valu Guide brackets, spacers and rail clamps, the adjusting rods must be held in a parallel position for smooth adjustment while the pivoting clevis can be attached at various angles to the guide rail. A simple release of the bracket hand knobs allows the rails to be adjusted to the desired position.

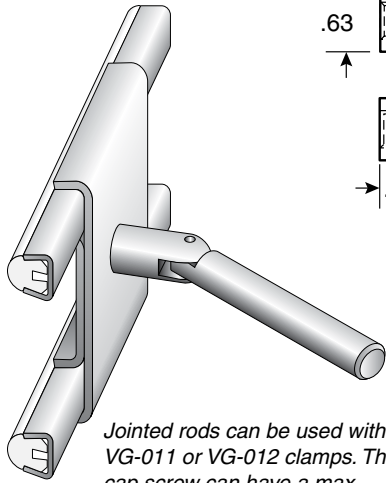

Jointed rods can be used with VG-011 or VG-012 clamps. The cap screw can have a max. stud length of 5/8 inch.

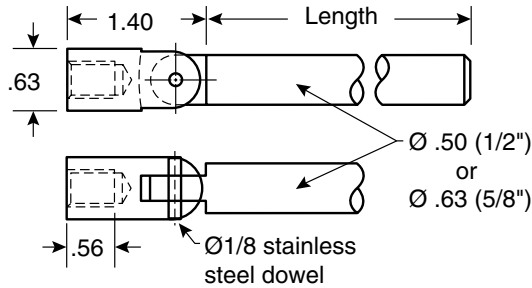

Material: Stainless steel.

Part Number	Ø (in.)	Length (in.)	Tapped Thread
VG-212J-3-516	1/2	3	5/16-18
VG-212J-3-38	1/2	3	3/8-16
VG-212J-5-516	1/2	5	5/16-18
VG-212J-5-38	1/2	5	3/8-16
VG-212J-7-516	1/2	7	5/16-18
VG-212J-7-38	1/2	7	3/8-16
VG-212J-9-516	1/2	9	5/16-18
VG-212J-9-38	1/2	9	3/8-16
VG-232J-4-516	5/8	4	5/16-18
VG-232J-4-38	5/8	4	3/8-16
VG-232J-6-516	5/8	6	5/16-18
VG-232J-6-38	5/8	6	3/8-16
VG-232J-8-516	5/8	8	5/16-18
VG-232J-8-38	5/8	8	3/8-16
VG-232J-10-516	5/8	10	5/16-18
VG-232J-10-38	5/8	10	3/8-16

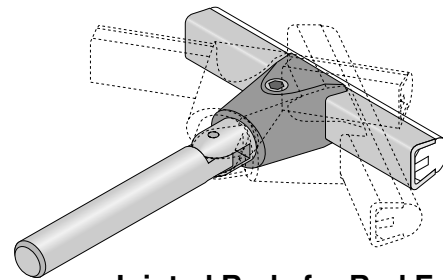

Jointed Rods for Rod Ends

VG-019-12 and VG-020-01 use special grooved adjusting rods. Jointed versions of these rods can be found on page 229.

Brackets & Positioning

Bracket Spacers for Jointed Rod Use.

VG-290 series spacers may be required for proper set back of VG-202 and VG-203 brackets to allow for the jointed adjusting rod clevis extension.

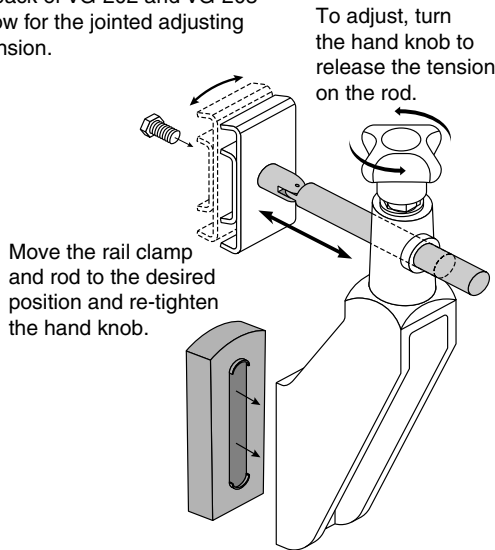

Special Clip for Jointed Rods and Fixed Threads.

Carriage bolts, captured hex bolts, or other threaded fasteners that do not rotate such as VG-018 or VG-015 rail clips, can attach to jointed rods with the new VG-040-01 clip. By using a hex head bolt to fasten the rod, the proper articulating plane can be maintained.

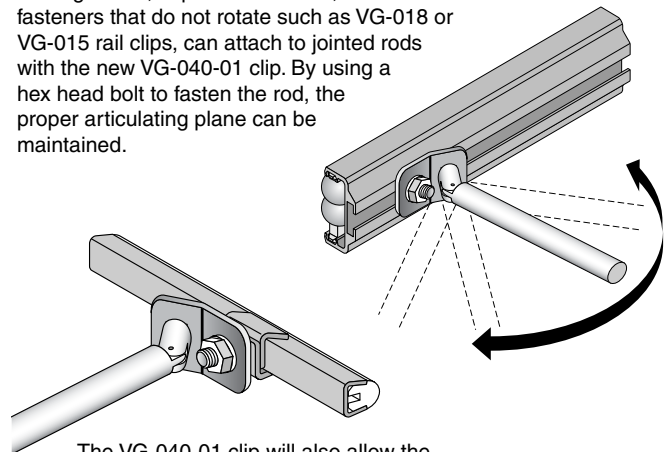

The VG-040-01 clip will also allow the use of a jointed rod when attaching to products with fasteners that do not rotate.



Fast, Accurate Changes!

SpeedSet™ Brackets solve conveyor line change problems...quickly. The benefit of SpeedSet is preset conveyor guide rail adjustability that is fast and accurate without the need for tools. SpeedSet is fast because a simple push on the end knob moves the rod, clamp, and guide rail. Within seconds, each rail holding point can be adjusted, saving valuable time on line changes. SpeedSet is accurate due to the innovative positioning spacer design. Customized to individual product requirements, positioning spacers accurately hold the rod and guide rail in position. Simply set the rails in "Home Position" for largest containers, and insert the positioning spacers for consistent spacing on smaller containers. Remove the blocks to return to the original "Home Position."

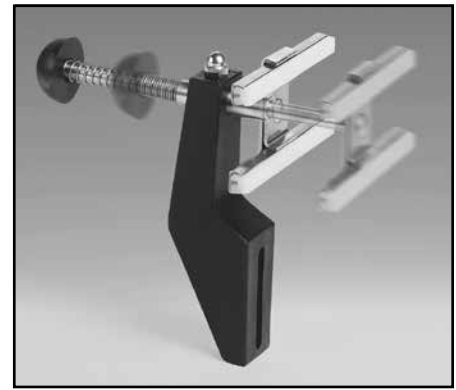

Positioning Spacers

3 types available, see page 300. Used to hold the rod in an extended position, insert positioning spacer between the rod sleeve and the guide rail holder. These spacers can be fabricated to provide a total of three positions within the Range of Travel (discussed later). One VG-QPC series spacer is included with each bracket.

Piston Rod

Tapped piston rod can accept a wide variety of Valu Guide rail holders (double rail clamp shown).

Rod Sleeve

The rod sleeve provides the reach to the largest conveyed container while the rod inside the sleeve adjusts to the smaller container.

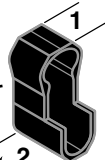

Collar hangs loose on rod sleeve for "Home Position"

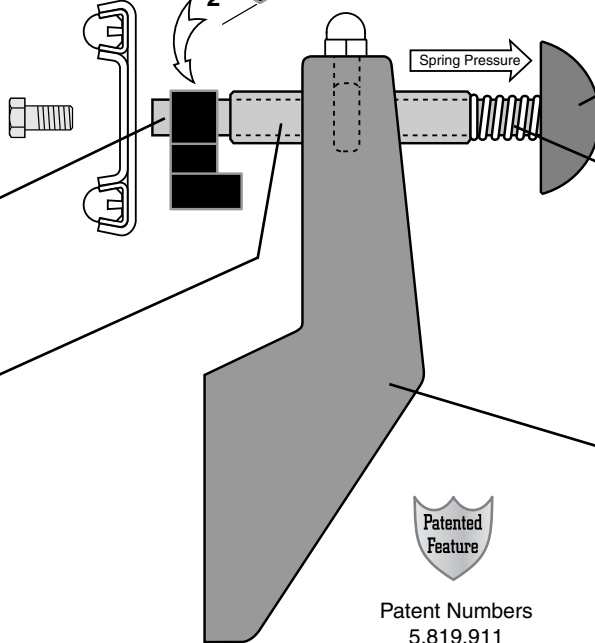

Push Knob

The push knob is designed to have pressure applied to move the rod and guide rails into a new position.

Spring

The spring maintains pressure which holds the positioning spacers and guide rail in place. When the positioning spacers are removed, the spring returns the guide rail to the "Home Position".

Brackets

Valu Guide brackets are slotted to allow vertical height adjustment. The use of bracket spacers, swivel tops, and stacking rings allows virtually any conveyor line to take advantage of SpeedSet.



Patent Numbers
5,819,911
5,967,295
6,135,271
6,533,110

HOME POSITION:

With the bracket nut loosened, the entire sleeve/rod assembly unit is located such that the rails are in the desired position for the largest container. Nut is then tightened, locking the entire assembly in place. Spring is not compressed and there is no spacer block in place.

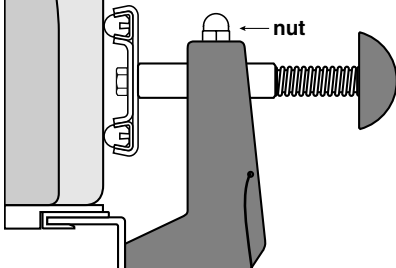

ADJUSTMENT:

Pushing on the knob compresses the spring, moving guide rail toward the smaller container.

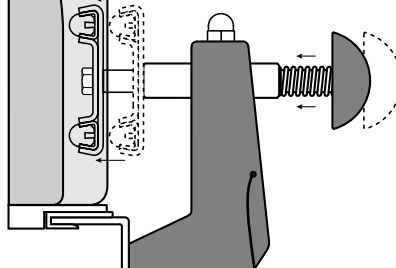

MODIFIED POSITION:

Positioning spacer is inserted and spring retracts rails into desired position.

Tethered Positioning Spacer shown.

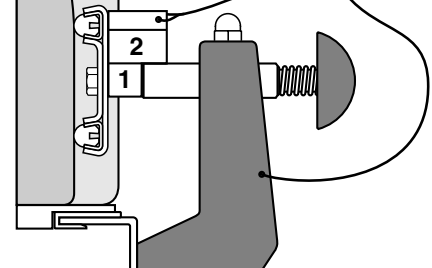



Step 1 Determining the Sleeve Length

The sleeve provides the reach needed to position the guide rails against the largest container. Valu Guide offers sleeves in 2", 3", and 5" lengths. Custom sleeve lengths are available. The sleeve is locked into place by tightening the acorn nut on top of the bracket. This is considered the home position. (see below) Further adjustment of the rails is achieved by sliding the piston rod through the sleeve.

The required sleeve length can be determined by measuring or calculating the distance from the edge of the largest container to the edge of the conveyor and adding 2". Once the calculation is done, select the next largest sleeve size.

$$\text{largest container to conveyor edge} + 2'' = \text{Minimum sleeve length}$$

Example: 2.5" + 2.0" = 4.5" (requires 5" sleeve)

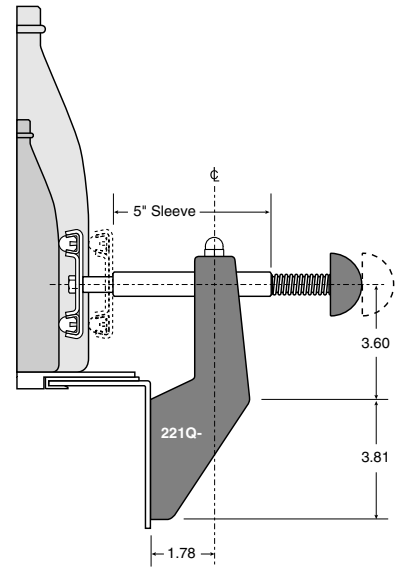

Step 2 Selecting the Range of Travel

The range of travel is defined as the distance that the guide rails must move to accommodate different container sizes. SpeedSet brackets are available with two ranges of travel: 1-1/2" and 2-1/2". These are maximum ranges, with the ability to adjust to any length within the maximum range.

To calculate the range of travel when *both* sides of the conveyor guide rail are adjusting, use the following formula:

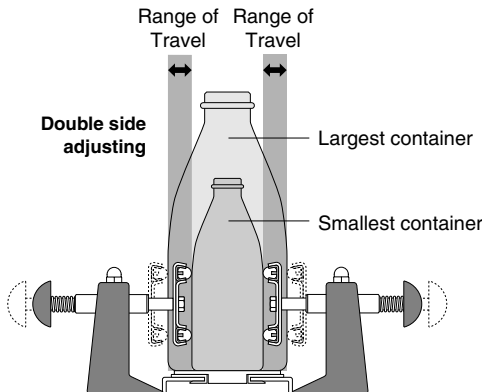

$$\text{largest container} - \text{smallest container} \div 2 = \text{range of travel for each side}$$

Example: 5" - 3" = 2" ÷ 2 = 1" travel per side

To calculate the range of travel when a *single* side of the conveyor guide rail is adjusting, use the following formula:

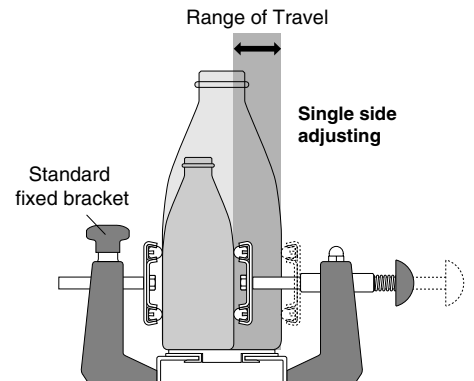

$$\text{largest container} - \text{smallest container} = \text{range of travel for a single side}$$

Example: 5" - 3" = 2" travel for one side

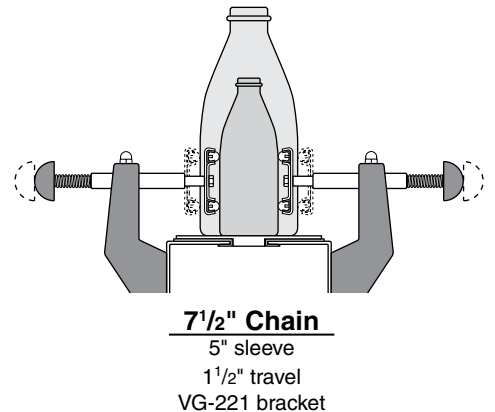
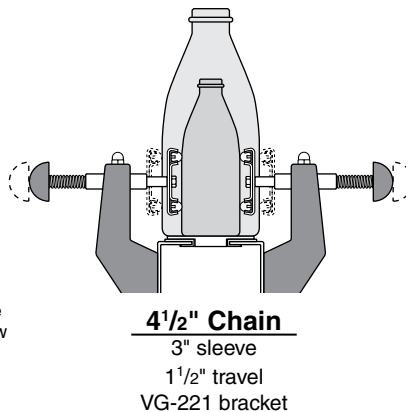
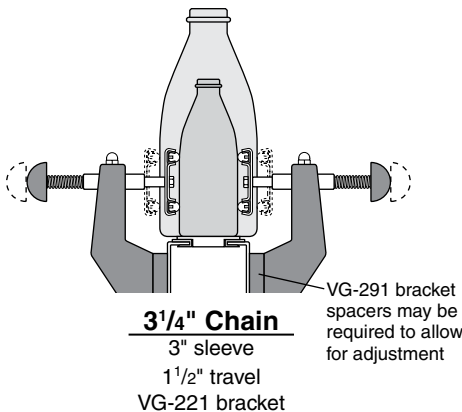

Brackets & Positioning



SpeedSet Brackets

SpeedSet Spacers Positioning for different size containers!

Three types of positioning spacers have been developed for SpeedSet brackets. A Positioning Collar is included with each SpeedSet bracket. The length of the spacer included with each bracket corresponds to the length of travel of the bracket ordered, either 1, 1-1/2 or 2-1/2 inches.

Some spacers can accommodate 3 positioning lengths including the "Home Position" by cutting to the required length as shown. Additional positioning spacers can be purchased in 18 inch lengths and cut to length as needed.

QSC

Precut Spacers in Colors

Color coding makes these spacers easy to work with while providing exact spacing for SpeedSet spring loaded brackets. Use VG-QT-01 tether to keep spacers close to brackets for future use. Color code up to 7 line change colors per bracket.

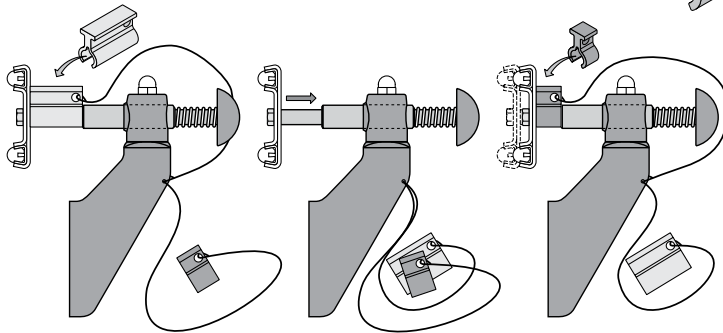
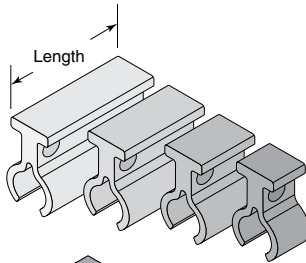

Material: Polypropylene

Part Number	Color	Length (in.)
VG-QSC-10M	Red	.39
VG-QSC-12M	Blue	.47
VG-QSC-16M	Black	.63
VG-QSC-20M	Green	.79
VG-QSC-25M	Purple	.98
VG-QSC-30M	Orange	1.18
VG-QSC-40M	Gray	1.58

Tether Material: Clear PVC.

Part Number	Length (in.)
VG-QT-01	9

QPC

Positioning Collar

This spacer, in 1, 1-1/2 or 2-1/2 inch length depending on travel chosen, is **included with each SpeedSet bracket**. A single spacer can accommodate 2 positioning lengths in addition to the "Home Position" by cutting as shown. To make additional spacers, 18 inch sections can be purchased and cut to length as needed. Use the following part number:



Material: Black PVC

Part Number	Length (in.)
VG-QPC-1.0	1
VG-QPC-1.5	1-1/2
VG-QPC-2.5	2-1/2
VG-QPC-18	18



Patent # 6,533,110

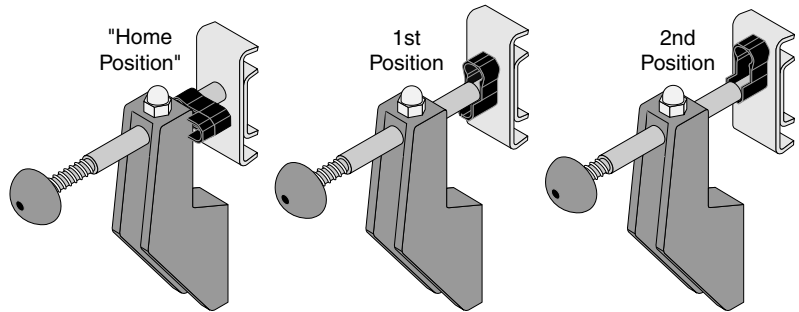
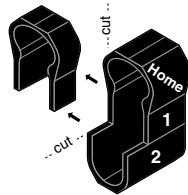

QSB

Positioning Spacer

A single spacer can accommodate 2 positioning lengths in addition to the "Home Position" by cutting as shown. To make additional spacers, 18 inch sections, can be purchased and cut to length as needed. Use VG-QT-01 tether to keep spacers close to brackets for future use.

Spacer Material: Gray PVC.

Part Number	Length (in.)
VG-QSB-1.0	1
VG-QSB-1.5	1-1/2
VG-QSB-2.5	2-1/2
VG-QSB-18	18

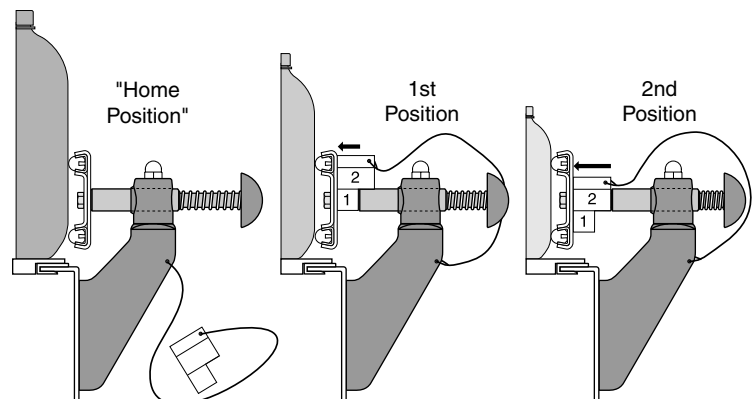
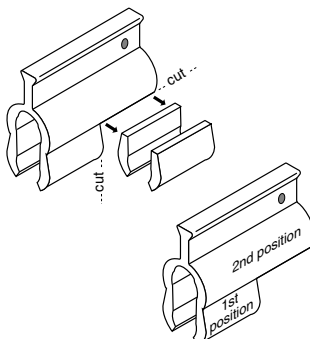

Tether Material: Clear PVC.

Part Number	Length (in.)
VG-QT-01	9

SpeedSet Brackets



Swivel Top SpeedSet Brackets

This bracket is required for curves, lane changes, and combiner areas, and allows in and out adjustments of the rails at any angle relative to the conveyor. For additional bracket body specifications, see VG-221 on page 291 and VG-210 on page 294.

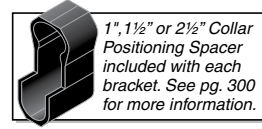

Materials: Polyamide bracket. Stainless steel rod and spring assembly. PVC push knob.

203Q

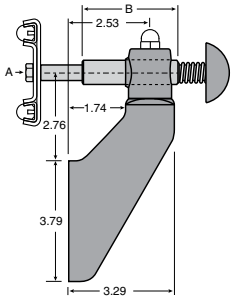

Adjustment Range (Travel):



Part Number	Part Number	Part Number	Tapped Rod Thread (A)	Sleeve Length (B)
VG-203Q-02-10-516			5/16	2
VG-203Q-03-10-516	VG-203Q-03-15-516		5/16	3
	VG-203Q-03-15-38		3/8	3
VG-203Q-05-10-516	VG-203Q-05-15-516	VG-203Q-05-25-516	5/16	5
VG-203Q-05-10-38	VG-203Q-05-15-38	VG-203Q-05-25-38	3/8	5

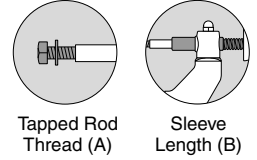

202Q

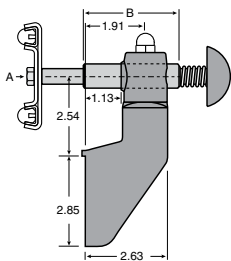

Part Number	Part Number	Part Number	Tapped Rod Thread (A)	Sleeve Length (B)
VG-202Q-02-10-516			5/16	2
VG-202Q-02-10-38			3/8	2
VG-202Q-03-10-516	VG-202Q-03-15-516		5/16	3
	VG-202Q-03-15-38		3/8	3
VG-202Q-05-10-516	VG-202Q-05-15-516	VG-202Q-05-25-516	5/16	5
VG-202Q-05-10-38		VG-202Q-05-25-38	3/8	5

Fixed SpeedSet Brackets

Used for straight running conveyors, this bracket style allows only in and out adjustments at a right angle to the conveyor. For additional bracket body specifications, see VG-221 on page 291 and VG-210 on page 294.

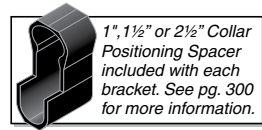

Materials: Polyamide bracket. Stainless steel rod and spring assembly. PVC push knob.

221Q

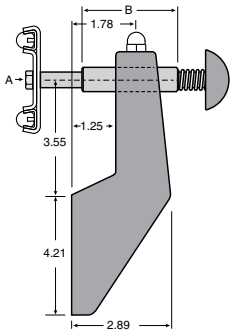

Adjustment Range (Travel):



Part Number	Part Number	Part Number	Tapped Rod Thread (A)	Sleeve Length (B)
VG-221Q-02-10-516			5/16	2
VG-221Q-02-10-38			3/8	2
VG-221Q-03-10-516	VG-221Q-03-15-516		5/16	3
	VG-221Q-03-15-38		3/8	3
VG-221Q-05-10-516	VG-221Q-05-15-516	VG-221Q-05-25-516	5/16	5
VG-221Q-05-10-38	VG-221Q-05-15-38	VG-221Q-05-25-38	3/8	5

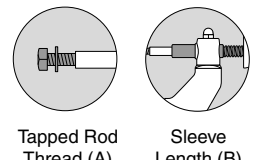

210Q

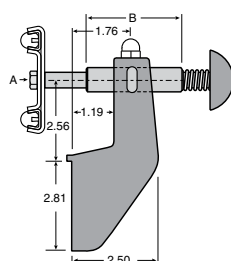

Part Number	Part Number	Part Number	Tapped Rod Thread (A)	Sleeve Length (B)
VG-210Q-02-10-516			5/16	2
VG-210Q-02-10-38			3/8	2
VG-210Q-03-10-516			5/16	3
	VG-210Q-03-15-38		3/8	3
	VG-210Q-05-15-516	VG-210Q-05-25-516	5/16	5
	VG-210Q-05-15-38	VG-210Q-05-25-38	3/8	5

Brackets & Positioning



SpeedSet Brackets

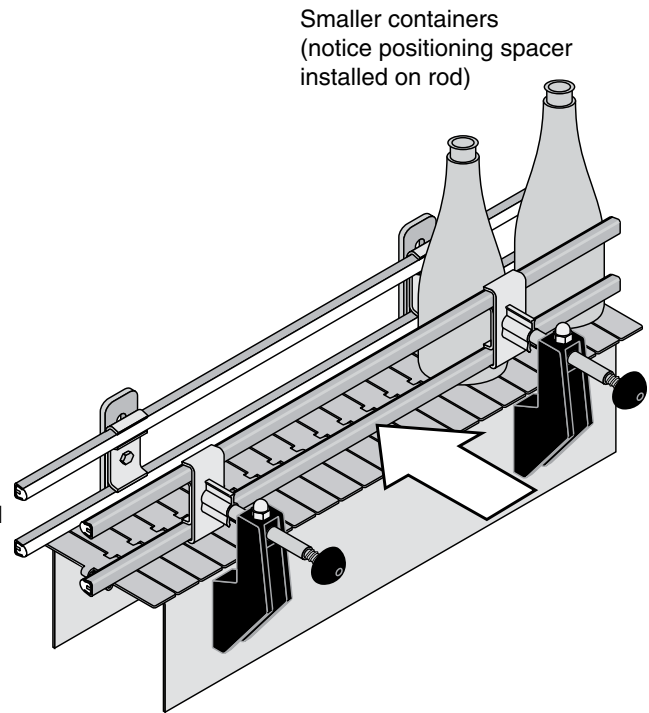
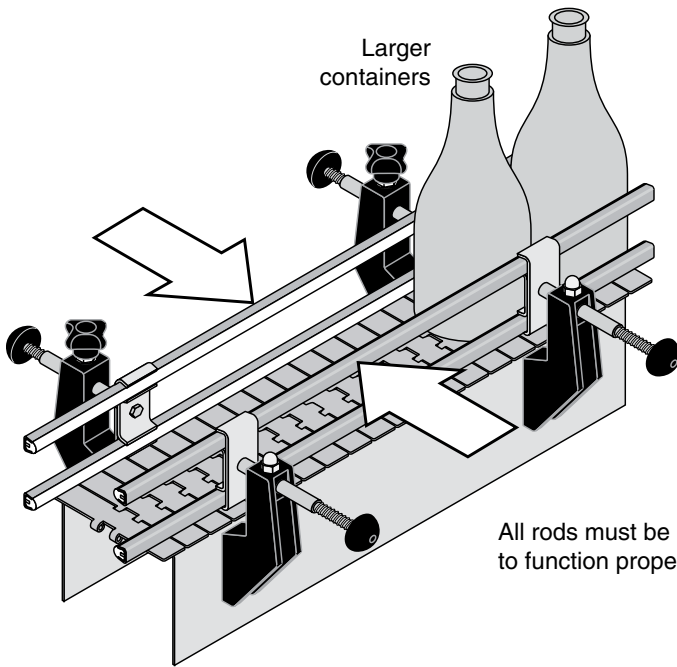
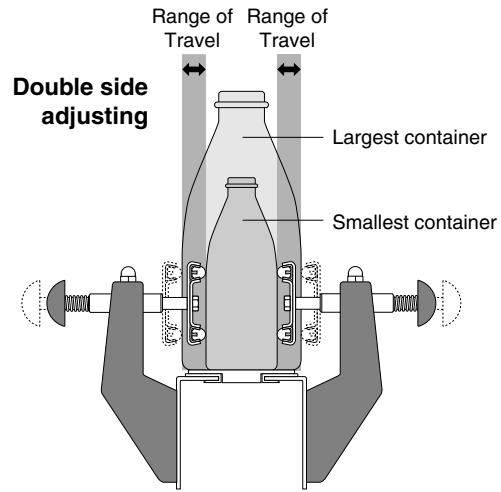
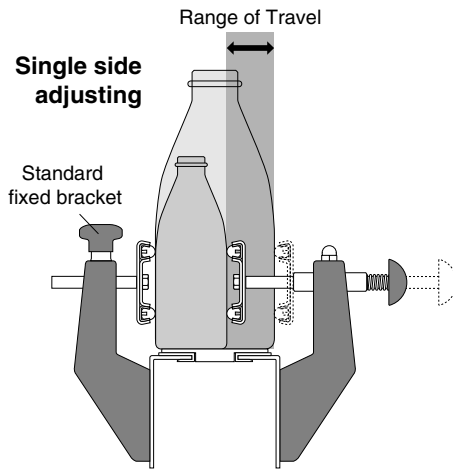

Brackets & Positioning

All rods must be parallel to function properly.

A: Rod length

B: Sleeve length

C: Bracket height

Types of Positioning

(A) Range of Rod Travel Rod lengths provide either 1, 1.5 or 2.5 inches of travel from the end of the sleeve. Positioning spacers (page 300) are used to counter the force of the spring, and hold the rod and guide rails in an extended position. The spacer size determines the distance that the rails are positioned away from the sleeve and bracket. If no positioning spacers are used, the rod is retracted by the spring, and the rails are at "Home Position".

(B) Sleeve The rod sleeve is available in 2, 3, and 5 inch lengths, and is positioned as needed in the bracket by tightening the acorn nut. Further rail adjustments should be made through the use of positioning spacers.

(C) Bracket To help in finding the "Home Position" for the rod and guide rails, various bracket configurations can be used. Bracket sizes, bracket spacers, and stacking rings can be selected to best locate the rod. See page 306 for related components.



212JQ

Jointed SpeedSet Rod Adapter

Threads into any 3/8 or 5/16 inch tapped SpeedSet rod to provide adjustability for positioning rails through a radius curve.

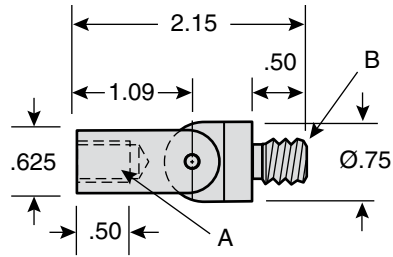
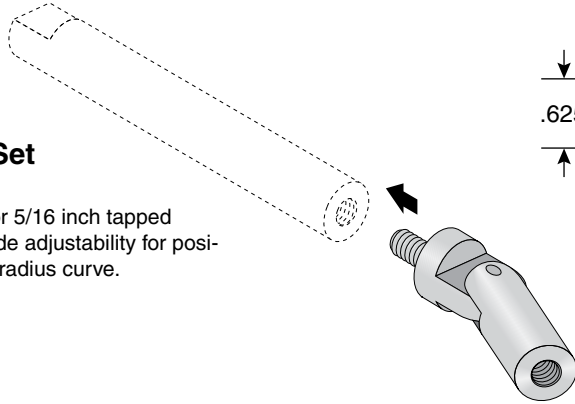

Material: Stainless steel.

Part Number	Tap & Stud Thread (A & B)
VG-212JQ-38	3/8
VG-212JQ-516	5/16

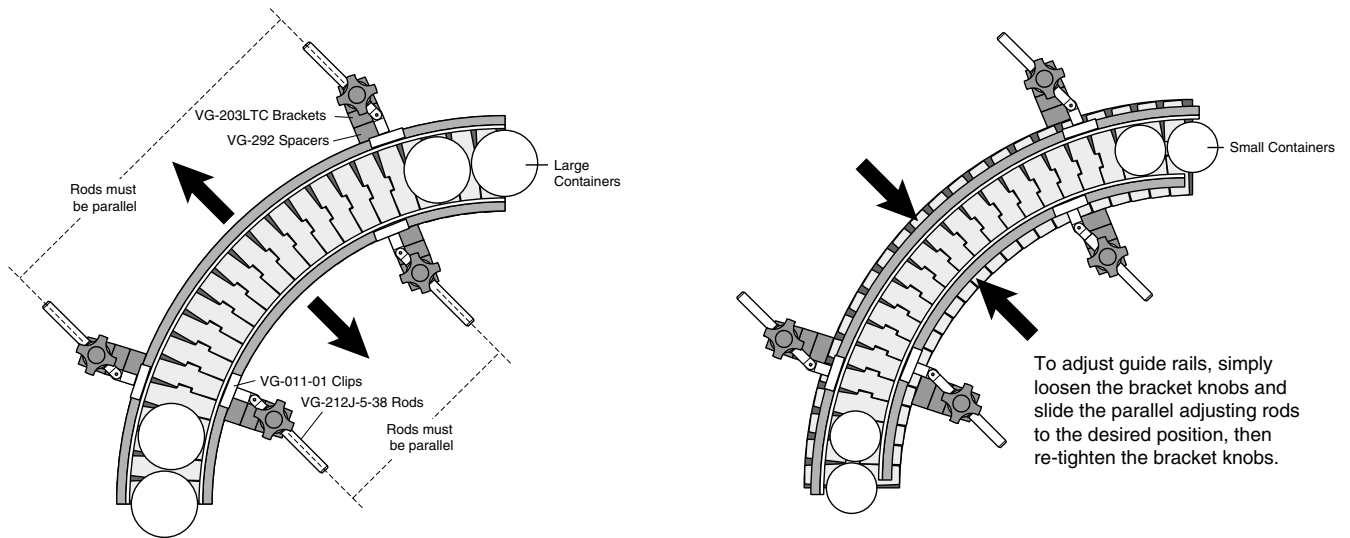

Brackets & Positioning

33298

Quick Adjust Head

Dual action knob provides simple and accurate adjustments. When adjustment is necessary, a simple turn of the quick release cap loosens the grip on the rod. When the adjustment is complete, retighten the cap to lock the new position in place. Can be used with any System Plast bracket.



Material: Polyamide, nickel plated brass.

Part Number	Ø Rod
33298	1/2

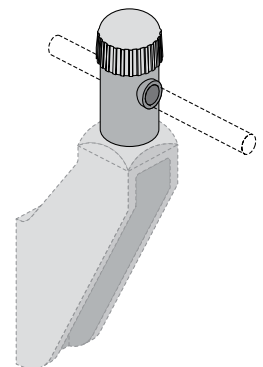
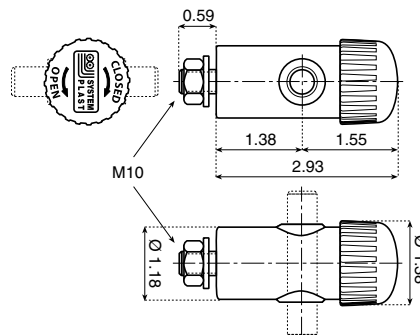
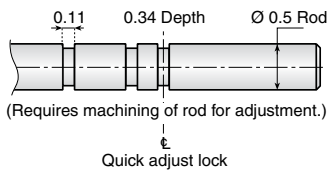

**SYSTEM
PLAST™**

Molded Plastic "L" Brackets



Plastic "L" Brackets

Plastic "L" brackets are slotted for maximum adjustability, interchangeable, and can be used for upper or lower parts of a bracket assembly. The taller VG-245-K is especially useful as the top segment of an assembly where greater vertical adjustment is required.

As Strong as Steel!



In simple load tests, VG-245 plastic brackets have deflection properties comparable to the 3/16 in. thick VG-205 steel bracket.

Polyamide

The characteristics of **polyamide** resin make it an excellent material choice for molded component parts that must stand up to demanding industrial applications. System Plast uses reinforced polyamide to provide our customers with products, such as the plastic "L" brackets, that are dimensionally stable and have high mechanical strength. The brackets have high rigidity and toughness, resistance to heat deformation, and resistance to many chemicals. Continuous operating temperature range: -4°F to +190°F. Withstands intermittent temperatures up to 220°F.

245-H

Single Slot Bracket

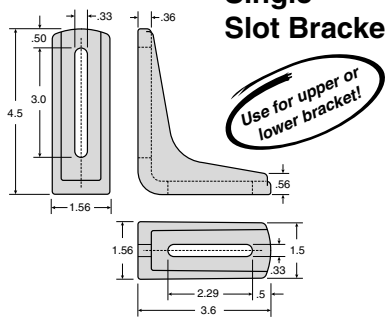

Material: Reinforced Polyamide.

Part Number	Black	Gray
VG-245-H-BK	•	
VG-245-H-GR		•

245-J

Double Slot Bracket

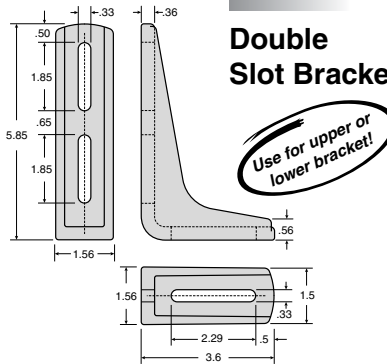

Material: Reinforced Polyamide.

Part Number	Black
VG-245-J-BK	•

245-K

Double Slot Bracket

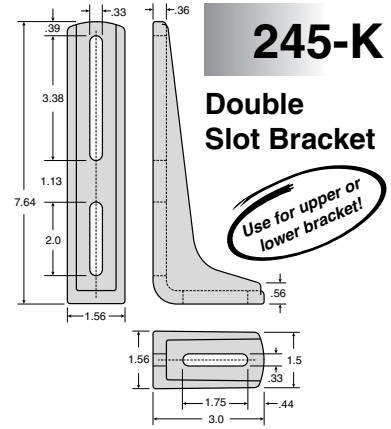

Material: Reinforced Polyamide.

Part Number	Black	Gray
VG-245-K-BK	•	
VG-245-K-GR		•

Brackets & Positioning

Plastic Offset "L" Brackets

Offset brackets are designed to intentionally set back the upper guide rail in a double guide rail configuration. This allows the container to be guided primarily by the lower guide rail. The upper guide rail acts as a secondary guide only when the container is tipping. Each bracket is slotted for maximum adjustability and the taller top segment is available for greater vertical adjustment.

245-L

Double Slot Offset Bracket

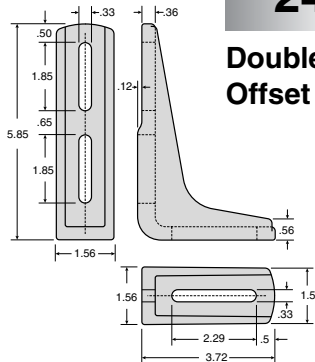

Material: Reinforced Polyamide.

Part Number	Black	Gray
VG-245-L-BK	•	
VG-245-L-GR		•

245-M

Double Slot Offset Bracket

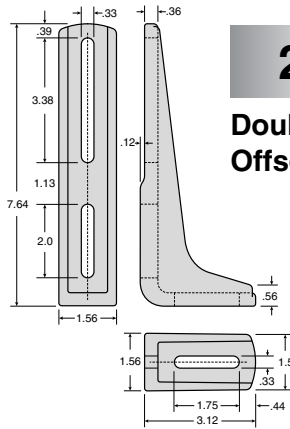

Material: Reinforced Polyamide.

Part Number	Black
VG-245-M-BK	•

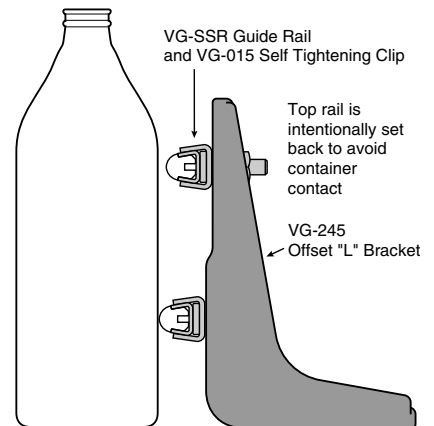



Hardware Assemblies

For all VG-245 bracket assemblies.

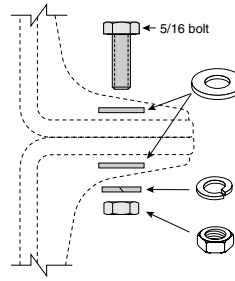
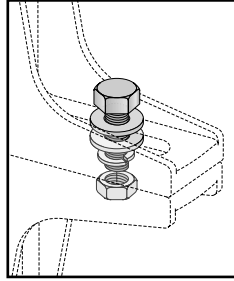

Material: Stainless steel.

Part Number
VG-245-HDW-01-S516

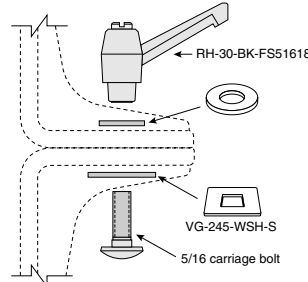
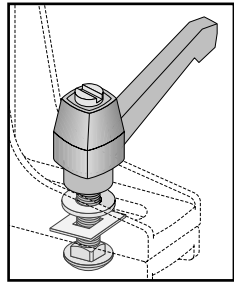

Material: Polyamide ratchet handle, stainless steel hardware.

Part Number
VG-245-HDW-02-S516

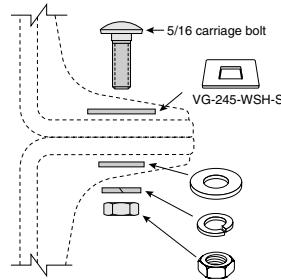
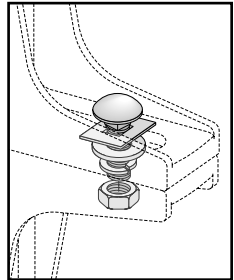

Material: Stainless steel.

Part Number
VG-245-HDW-03-S516

Square Washer

Prevents carriage bolt heads from stripping out the bracket slot. Recommended for use with 5/16 carriage bolts.

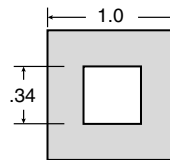
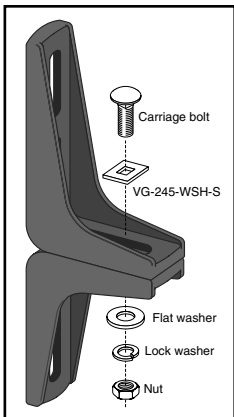

Material: 18 ga. stainless steel.

Part Number
VG-245-WSH-S

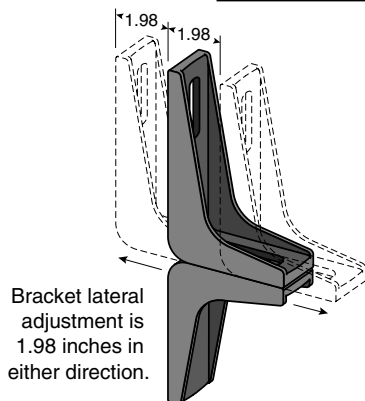

Bracket lateral adjustment is 1.98 inches in either direction.

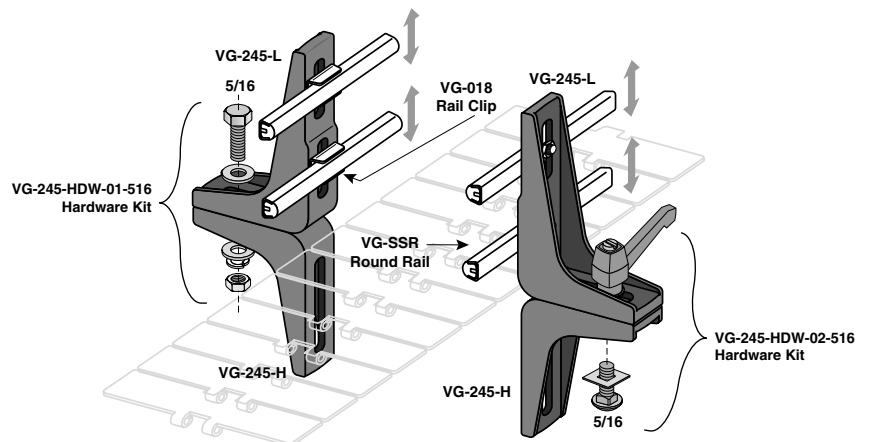

Brackets & Positioning



290 and 291

Spacers

Used to increase the distance between VG-202 or VG-210 series brackets and the mounting surface. VG-291 is designed to be used with the bracket or in multiples when the squaring lip is desired. The VG-290 is used with the bracket or the VG-291 when no lip is desired.

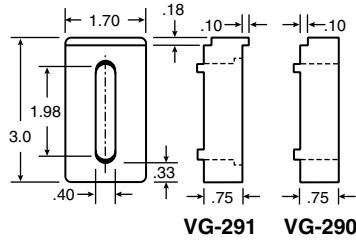

Material: Polyamide.

Part Number

VG-290

VG-291

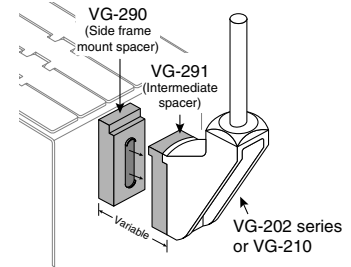

292

Spacer

Used to increase the distance between VG-203 series brackets and the mounting surface. May be used in multiples.

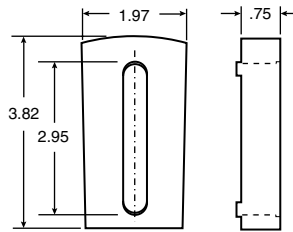

Material: Polyamide.

Part Number

VG-292

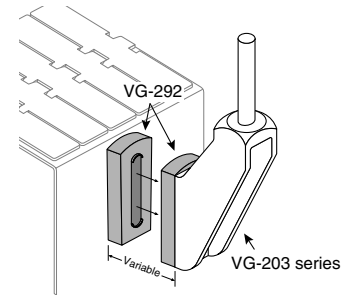

131136

Spacer

Used to increase the distance between VG-221 series brackets and the mounting surface. May be used in multiples.

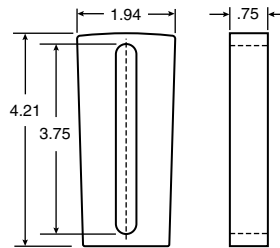

Material: Polyamide.

Part Number

131136

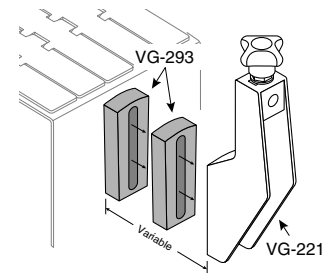

VSR

Stacking Ring

Use with VG-202/203 brackets and cap series where increased height is necessary.



Material: Polyamide.

Part Number

VG-VSR

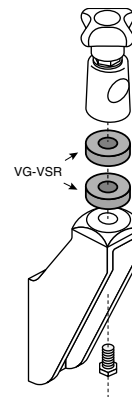

Note: When stacking rings are used, rod center line changes and a longer bolt is required.

Bracket Hand Knobs

280

Female Knob

Used alone or as replacement for VG-202TC bracket caps and VG-210 brackets.

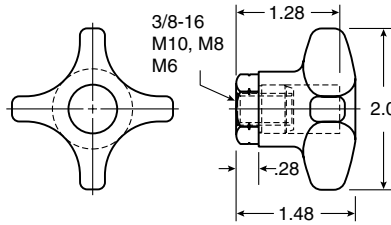

Material: Polyamide (PA) or Polypropylene (PP) knob. Nickel plated brass knob bushing.

Part Number	Material	Thread
VG-280-38F	PA	3/8-16
VG-280-M10F	PA	M10
VG-280-M8F	PA	M8
VG-280-M6F	PA	M6
VG-280PP-38F	PP	3/8-16
VG-280PP-M10F	PP	M10
VG-280PP-M8F	PP	M8
VG-280PP-M6F	PP	M6

280

Male Knob

Used alone or as replacement for VG-202H series bracket caps.

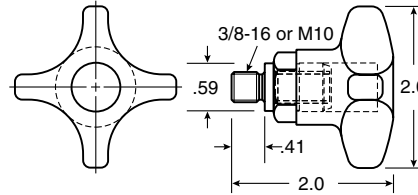

Part Number	Material	Thread
VG-280-38M	PA	3/8-16
VG-280-M10M	PA	M10

280K

Female Knob

Used alone or as part of VG-253K bracket.

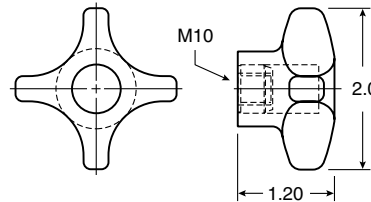

Part Number	Material	Thread
VG-280K	PA	M10

281

Female Knob

Used alone or as replacements for VG-621 cross blocks. Insert is molded into the knob.

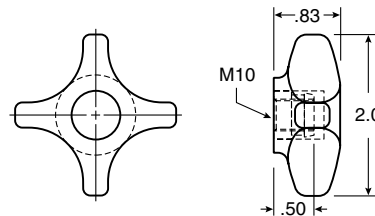

Part Number	Material	Thread
VG-281-M10F	PA	M10

282

Female Knob

Used alone or as replacements for VG-203TC series bracket caps and VG-221 brackets.

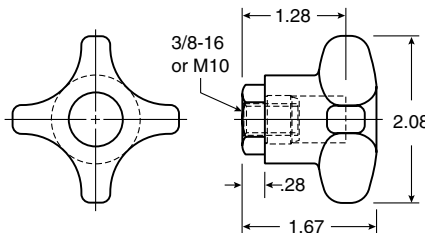

Part Number	Material	Thread
VG-282-38F	PA	3/8-16
VG-282-M10F	PA	M10
VG-282PP-38F	PP	3/8-16
VG-282PP-M10F	PP	M10

282

Male Knob

Used alone or as replacement for VG-203H series bracket caps.

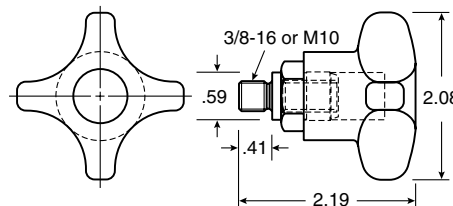

Part Number	Material	Thread
VG-282-38M	PA	3/8-16
VG-282-M10M	PA	M10

Brackets & Positioning



Rod Mount Brackets with Bolts

254B

Small Bracket with Hex Head Bolt

Set screw fastening provides holding and positioning of $\text{\O}1/2$ in. rods. Heavy duty construction for increased strength and rigidity.

All stainless steel for Hi-Temp and Corrosive applications

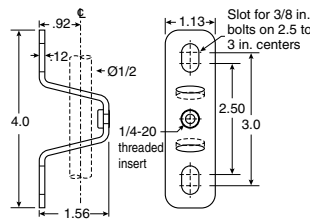
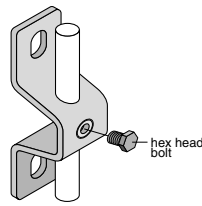

Material: 10 ga. stainless steel bracket and hex head bolt.

Part Number	\O Rod (in.)
VG-254B-S-12	1/2

Rod not included.

253B

Bracket with Hex Head Bolt

Set screw fastening provides holding and positioning of $\text{\O}1/2$, $\text{\O}5/8$ and $\text{\O}3/4$ in. rods. Heavy duty construction for increased strength and rigidity.

All stainless steel for Hi-Temp and Corrosive applications

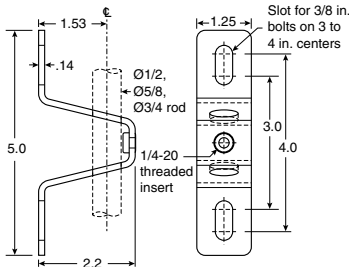
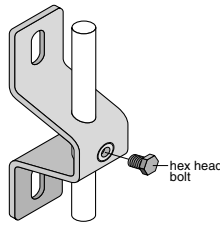

Material: 10 ga. stainless steel bracket and hex head bolt.

Part Number	\O Rod (in.)
VG-253B-S-12	1/2
VG-253B-S-58	5/8
VG-253B-S-34	3/4

Rod not included.

253N

Bracket with Eyelet and Nut

Provides holding and positioning of $\text{\O}1/2$, $\text{\O}5/8$ and $\text{\O}3/4$ in. rods. Heavy duty construction for increased strength and rigidity.

All stainless steel for Hi-Temp and Corrosive applications

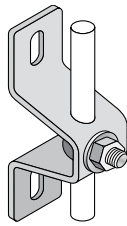

Eyelet does not mark rod surface!

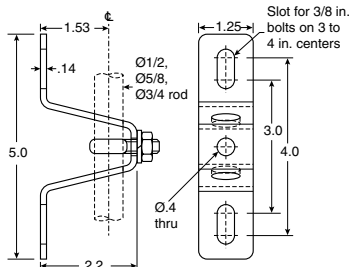

Material: 10 ga. stainless steel bracket. Stainless steel hardware.

Part Number	\O Rod (in.)
VG-253N-S-12	1/2
VG-253N-S-58	5/8
VG-253N-S-34	3/4

Rod not included.

Hand Knob Assembly

(eyelet, washer and knob)
Included with 253K bracket. Knob only is available as part no. VG-280K

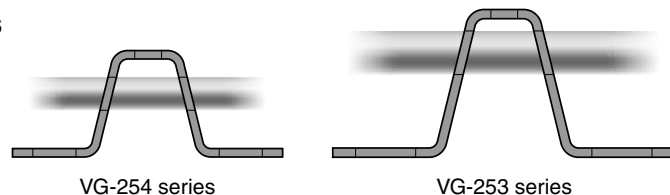
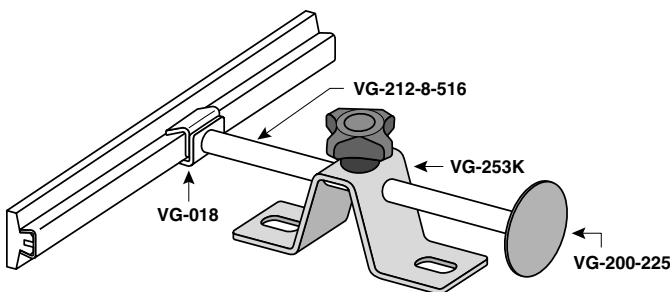
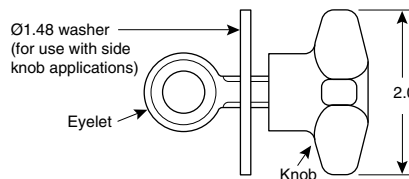

VG-254 series

VG-253 series

Brackets & Positioning



254K



Small Bracket with Hand Knob

Provides holding and positioning of $\varnothing 1/2$ in. rods. Heavy duty construction for increased strength and rigidity.

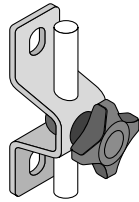

Eyelet does not mark rod surface!

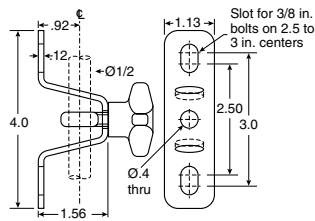

Material: 10 ga. stainless steel bracket. Stainless steel eyelet. Polyamide hand knob.

Part Number \varnothing Rod (in.)

VG-254K-S-12 **1/2**

Rod not included.

253K



Bracket with Hand Knob

Provides holding and positioning of $\varnothing 1/2$, $\varnothing 5/8$ and $\varnothing 3/4$ in. rods. Heavy duty construction for increased strength and rigidity.

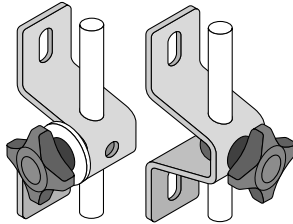

Eyelet does not mark rod surface!

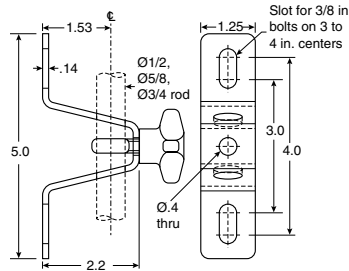

Material: 10 ga. stainless steel bracket. Stainless steel eyelet. Polyamide hand knob.

Part Number \varnothing Rod (in.)

VG-253K-S-12 **1/2**

VG-253K-S-58 **5/8**

VG-253K-S-34 **3/4**

Rod not included.

33231



Bracket with Hand Knob

Knob fastening provides holding and positioning for rods. Heavy duty construction for increased strength and rigidity.

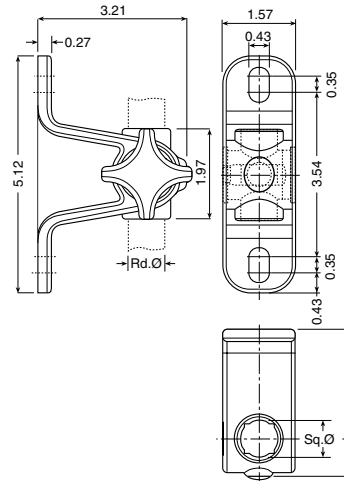

Material: Reinforced polyamide bracket and hand knob. Stainless steel eyelet and washer. Nickel plated brass insert.

Part Number \varnothing Rod \varnothing Rod

33231 **1/2** **7/16**

Rod not included.

Brackets & Positioning

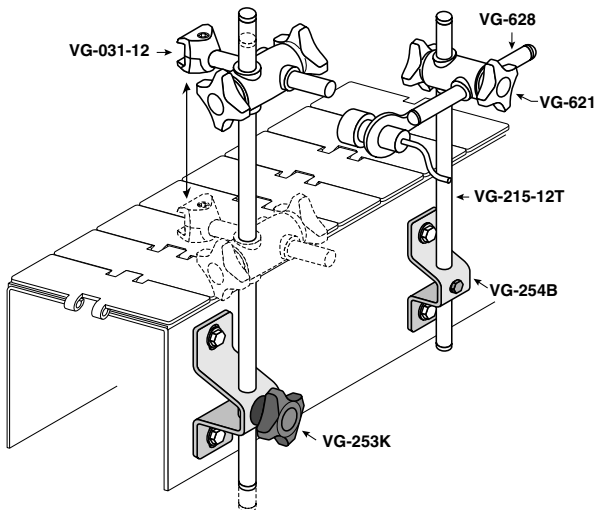

See page 296 for solid adjusting rods or page 336 for support rods with end caps.

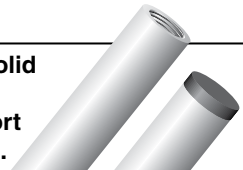



Stainless Steel Brackets

- Sanitary stainless steel construction
- Ideal for high temperature or corrosive environments
- Fixed or swivel versions
- Several sizes and shapes available

Hi-Temp
Resistant

Sanitary

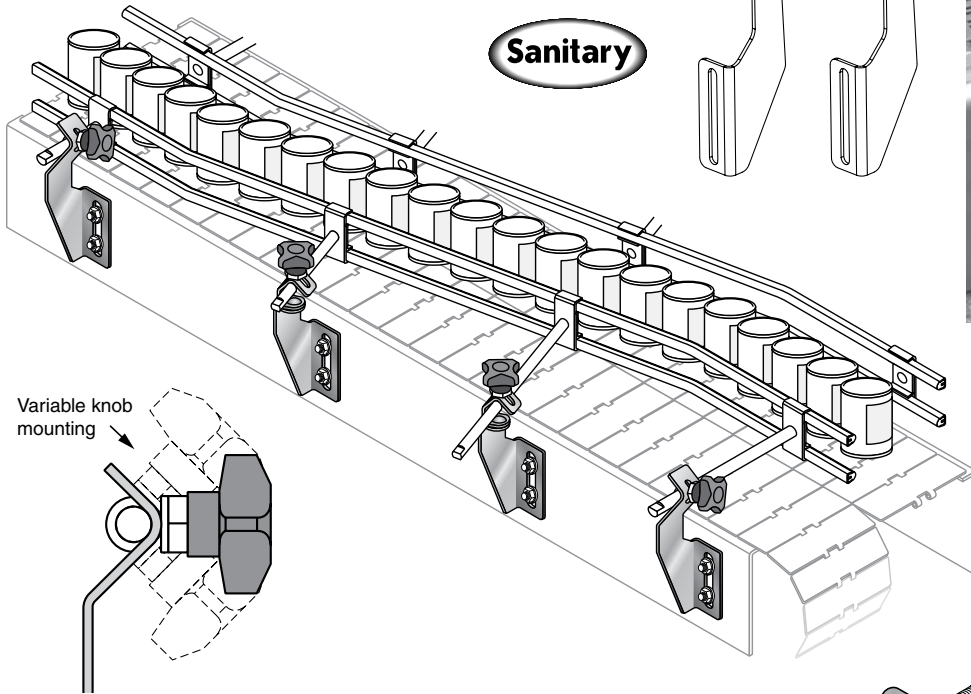
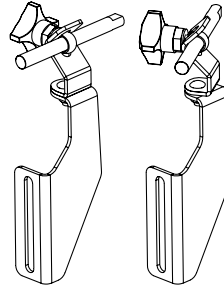

Variable knob
mounting

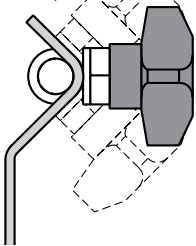

Patented
Feature

Patent #
6,189,685
6,669,009
6,752,260

Brackets &
Positioning

213-01

Stainless Steel Bracket

Guide rail support where lateral adjustment is needed. Sanitary design. Hi-temp. and corrosion resistant.

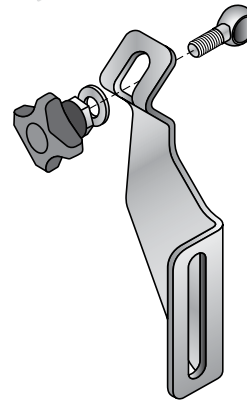

Material: Stainless steel
bracket, 11ga. Polyamide knob.

Part Number	Ø Rod (in.)
VG-213-12-01	1/2"
VG-213-58-01	5/8"

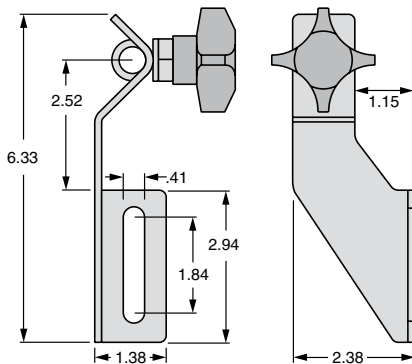

All stainless
steel for Hi-Temp
and Corrosive
applications

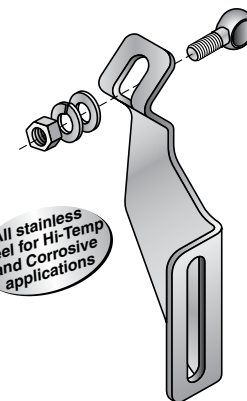

Material: Stainless steel
bracket, 11ga. Stainless nut.

Part Number	Ø Rod (in.)
VG-213N-12-01	1/2"
VG-213N-58-01	5/8"
VG-213N-34-01	3/4"

**SYSTEM
PLAST™**

©2015 Regal-Beloit Corporation, All Rights Reserved.



213T-01

Stainless Steel Bracket with Positioning Tab

Guide rail support where lateral adjustment is needed. Sanitary design. Hi-temp. and corrosion resistant.

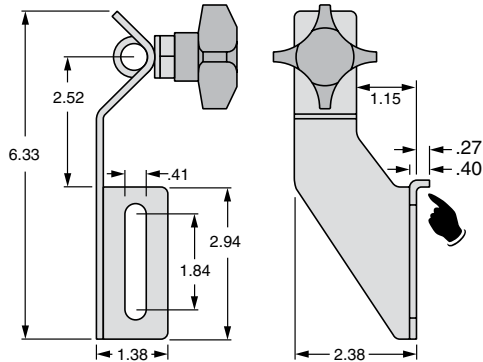

Special Optional Feature! Brackets can be ordered with a positioning tab which allows for **one-bolt** mounting and helps to square the bracket with the conveyor.

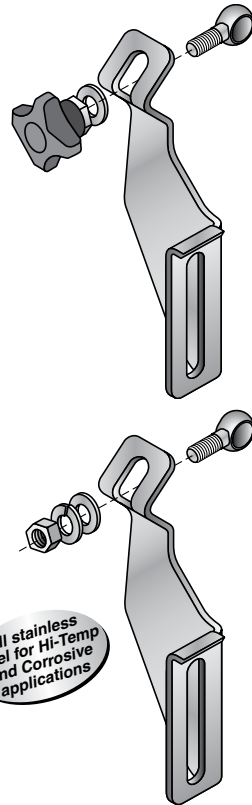

Material: Stainless steel bracket, 11 ga. Polyamide knob.

Part Number	Ø Rod (in.)
VG-213T-12-01	1/2"
VG-213T-58-01	5/8"

Material: Stainless steel bracket, 11 ga. Stainless nut.

Part Number	Ø Rod (in.)
VG-213TN-12-01	1/2"
VG-213TN-58-01	5/8"

213-02

Extended Stainless Steel Bracket

Guide rail support where lateral adjustment and setback spacing are needed. Sanitary design. Hi-temp. and corrosion resistant.

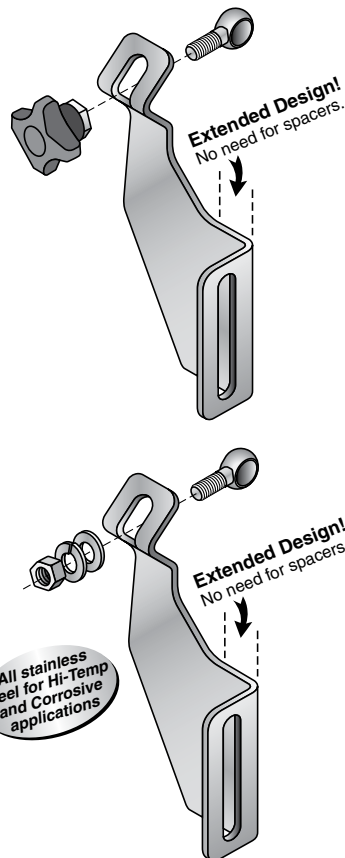
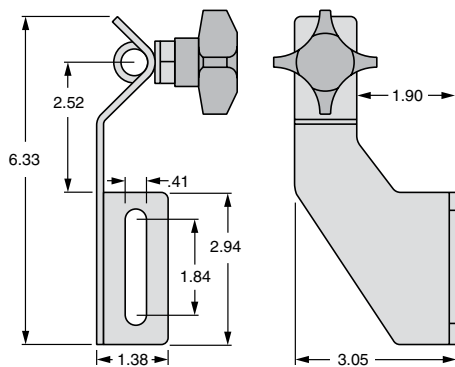

Material: Stainless steel bracket, 11 ga. Polyamide knob.

Part Number	Ø Rod (in.)
VG-213-12-02	1/2"
VG-213-58-02	5/8"

Material: Stainless steel bracket, 11 ga. Stainless nut.

Part Number	Ø Rod (in.)
VG-213N-12-02	1/2"

Brackets & Positioning



Stainless Steel Brackets

213R

Rotating Stainless Steel Bracket

Guide rail support where lateral adjustment and rotation are needed. Sanitary design. Hi-temp. and corrosion resistant.

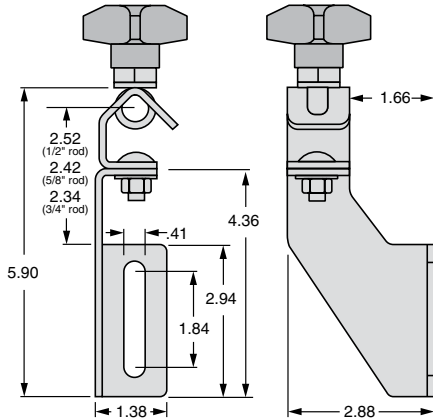

Patent #
6,189,685
6,543,608
6,669,009
6,752,260

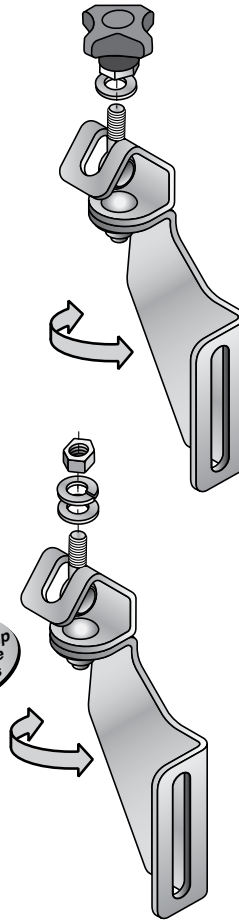

All stainless steel for Hi-Temp and Corrosive applications

Material: Stainless steel bracket, 11ga. Polyamide knob.

Part Number	Ø Rod (in.)
VG-213R-12-01	1/2"
VG-213R-58-01	5/8"

Base Only

VG-213R-B

Material: Stainless steel bracket, 11ga. Stainless nut.

Part Number	Ø Rod (in.)
VG-213RN-12-01	1/2"
VG-213RN-34-01	3/4"

Base Only

VG-213R-B



Brackets & Positioning

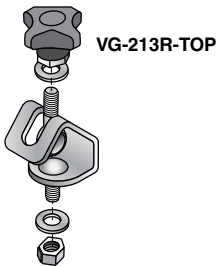

VG-213R-TOP

213R-TOP Rotating Top For Stainless Steel Bracket

Part Number
VG-213R-TOP-12
VG-213R-TOP-58
VG-213R-TOP-34

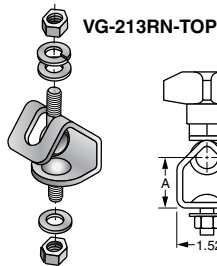

VG-213RN-TOP

213RN-TOP Rotating Top with Nut Fastener For Stainless Steel Bracket

Part Number	A	Dia. Rod
VG-213RN-TOP-12	1.13	1/2"
VG-213RN-TOP-58	1.03	5/8"
VG-213RN-TOP-34	.95	3/4"

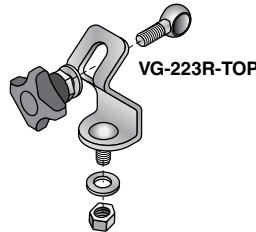
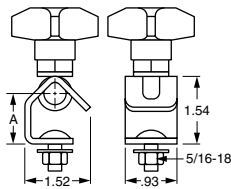

VG-223R-TOP

223R-TOP Rotating Top For Heavy Duty Stainless Steel Bracket

Part Number
VG-223R-TOP-12
VG-223R-TOP-58
VG-223R-TOP-34

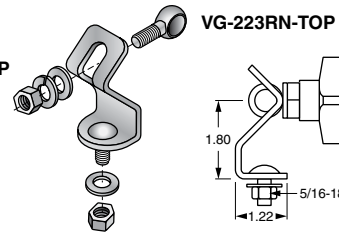

VG-223RN-TOP

223RN-TOP Rotating Top with Nut Fastener For Heavy Duty Stainless Steel Bracket

Part Number	Diameter Rod
VG-223RN-TOP-12	1/2"
VG-223RN-TOP-58	5/8"
VG-223RN-TOP-34	3/4"

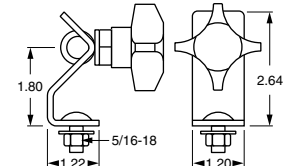



223-01

Heavy Duty, Stainless Steel Bracket

Guide rail support where lateral adjustment is needed. Sanitary design. Hi-temp. and corrosion resistant.

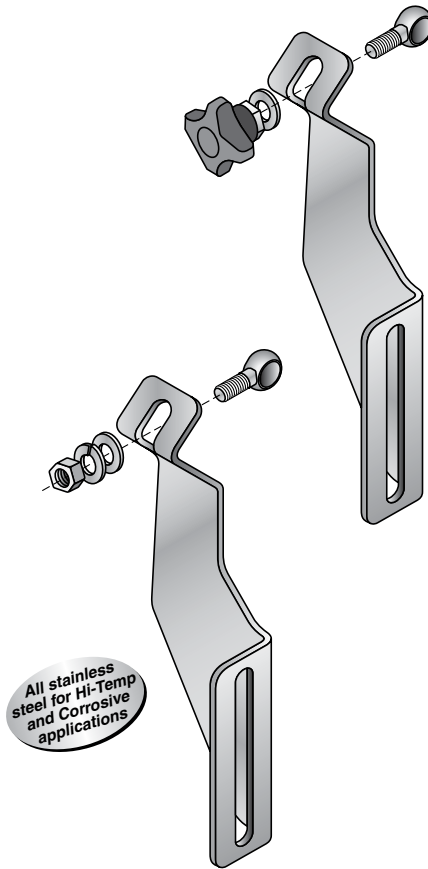
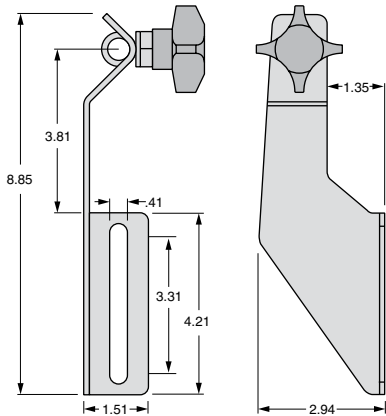

Patent #
6,189,685
6,669,009
6,752,260

Material: Stainless steel bracket, 11ga. Polyamide knob.	
Part Number	Ø Rod (in.)
VG-223-12-01	1/2"
VG-223-58-01	5/8"
VG-223-34-01	3/4"

Material: Stainless steel bracket, 11ga. Stainless nut.	
Part Number	Ø Rod (in.)
VG-223N-12-01	1/2"
VG-223N-34-01	3/4"

223-02

Heavy Duty, Extended Stainless Steel Bracket

Guide rail support where lateral adjustment and setback spacing are needed. Sanitary design. Hi-temp. and corrosion resistant.

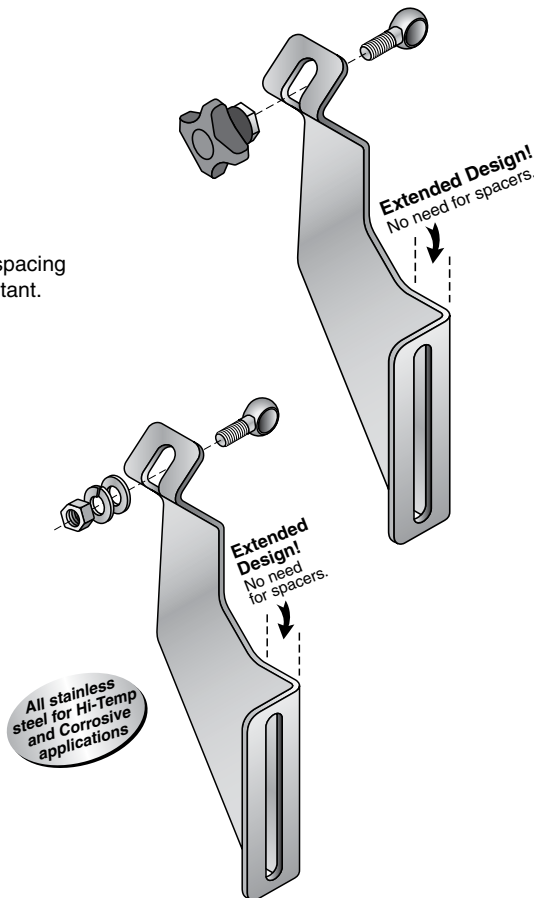
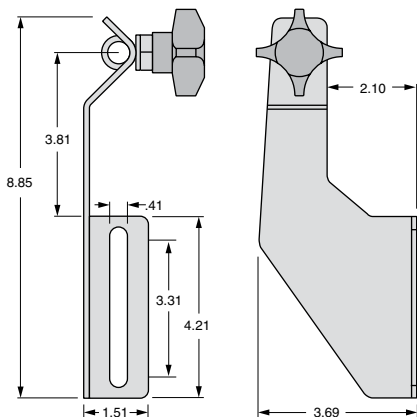

Material: Stainless steel bracket, 11ga. Polyamide knob.	
Part Number	Ø Rod (in.)
VG-223-12-02	1/2"
VG-223-58-02	5/8"
VG-223-34-02	3/4"

Material: Stainless steel bracket, 11ga. Stainless nut.	
Part Number	Ø Rod (in.)
VG-223N-12-02	1/2"
VG-223N-58-02	5/8"
VG-223N-34-02	3/4"

Brackets & Positioning



223R

Heavy Duty, Rotating Stainless Steel Bracket

Guide rail support where lateral adjustment is needed.
Sanitary design. Hi-temp. and corrosion resistant.



Patent #
6,189,685
6,543,608
6,669,009
6,752,260

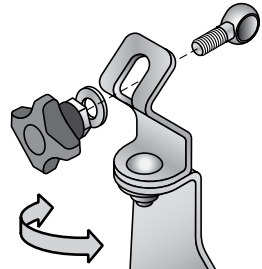

Material: Stainless steel
bracket, 11 ga. Polyamide knob.

Part Number	Ø Rod (in.)
VG-223R-12-01	1/2"
VG-223R-58-01	5/8"
VG-223R-34-01	3/4"

Base Only

VG-223R-B

Material: Stainless steel
bracket, 11 ga. Stainless nut.

Part Number	Ø Rod (in.)
VG-223RN-12-01	1/2"
VG-223RN-58-01	5/8"
VG-223RN-34-01	3/4"

Base Only

VG-223R-B

All stainless
steel for Hi-Temp
and Corrosive
applications

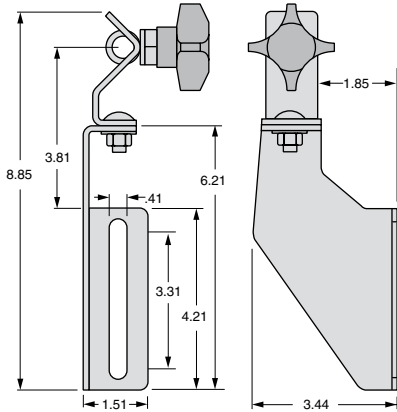

Brackets &
Positioning

223F-01

Heavy Duty, Stainless Steel Bracket with Flat Slot

Sanitary design. Hi-temp. and corrosion resistant.
Can be used with various bracket heads or position-
ing devices (not included).

Material: Stainless steel, 11 ga.

Part Number

VG-223F-01

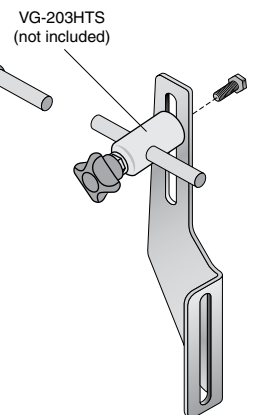
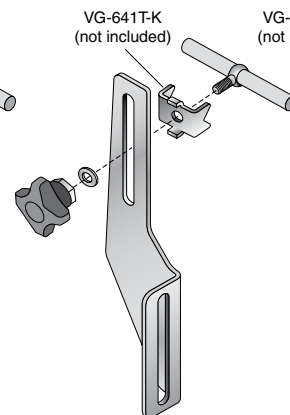
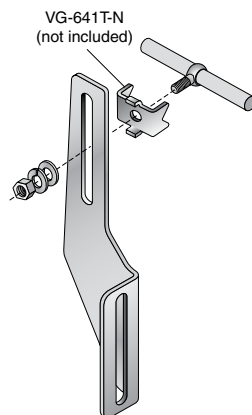
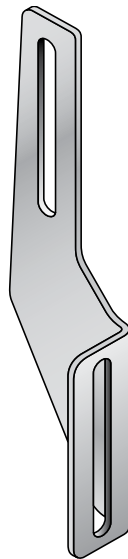
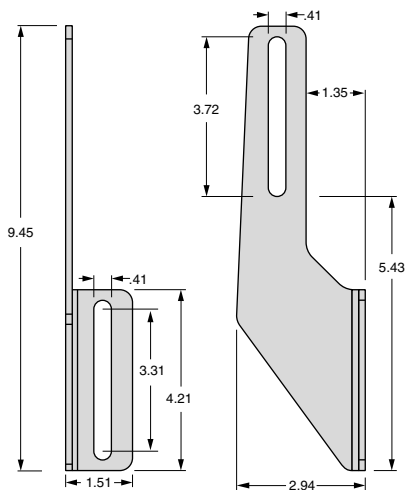

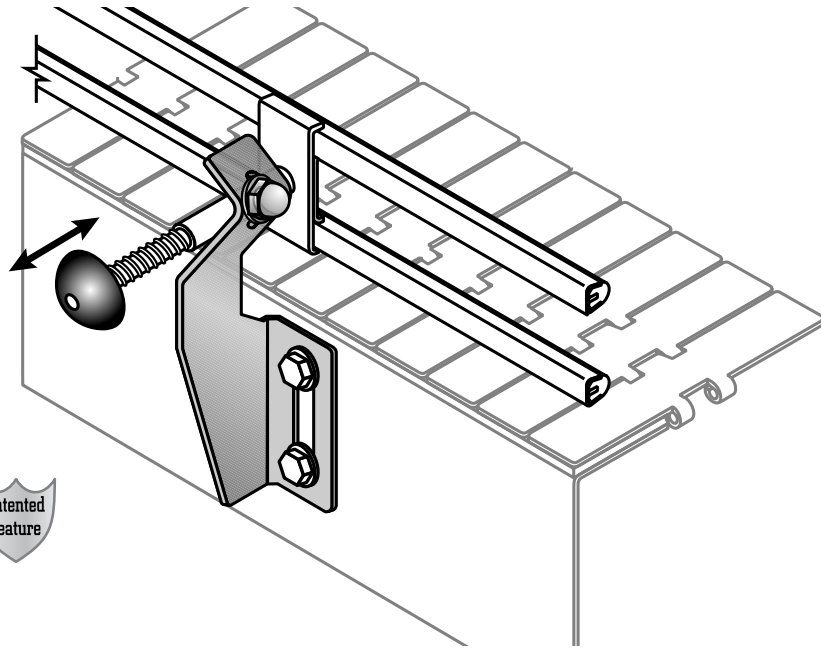

Patented Feature

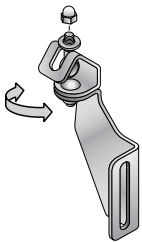

Swivel Top SpeedSet Brackets

This bracket is required for curves, lane changes, and combiner areas, and allows in and out adjustments of the rails at any angle relative to the conveyor. For additional bracket body specifications, see VG-213 on page 310 and VG-223 on page 313.

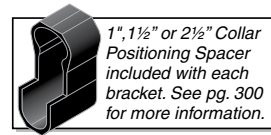

Materials: Stainless steel bracket, rod and spring assembly. PVC push knob.

213RQ

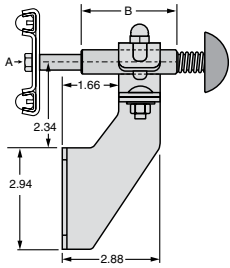

Adjustment Range (Travel):

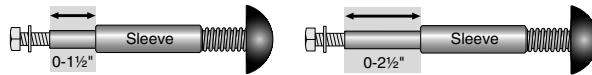

Part Number	Part Number	Tapped Rod Thread (A)	Sleeve Length (B)
VG-213RQ-03-15-516		5/16	3
	VG-213RQ-05-25-516	5/16	5
	VG-213RQ-05-25-38	3/8	5

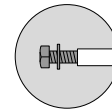

Tapped Rod Thread (A)

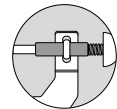

Sleeve Length (B)

223RQ

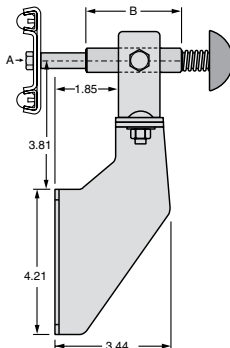

Part Number	Part Number	Tapped Rod Thread (A)	Sleeve Length (B)
VG-223RQ-03-15-38		3/8	3
	VG-223RQ-05-25-516	5/16	5
VG-223RQ-05-15-38	VG-223RQ-05-25-38	3/8	5

Brackets & Positioning



SpeedSet Metal Brackets

Fixed SpeedSet Brackets

Used for straight running conveyors, this bracket style allows only in and out adjustments at a right angle to the conveyor. For additional bracket body specifications, see VG-213 on page 310 and VG-223 on page 313.

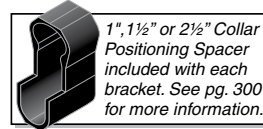

Materials: Stainless steel bracket, rod and spring assembly. PVC push knob.

213Q

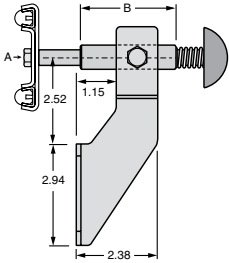

Adjustment Range (Travel):

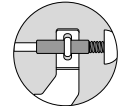
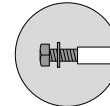
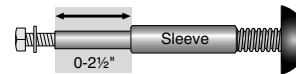

Part Number	Part Number	Part Number	Tapped Rod Thread (A)	Sleeve Length (B)
	VG-213Q-03-15-516		5/16	3
	VG-213Q-03-15-38		3/8	3
	VG-213Q-05-15-516	VG-213Q-05-25-516	5/16	5

223Q

Brackets & Positioning

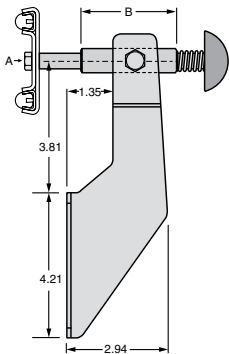

Part Number	Part Number	Part Number	Tapped Rod Thread (A)	Sleeve Length (B)
VG-223Q-02-10-516			5/16	2
			3/8	2
VG-223Q-03-10-516	VG-223Q-03-15-516		5/16	3
	VG-223Q-03-15-38		3/8	3
VG-223Q-05-10-516	VG-223Q-05-15-516	VG-223Q-05-25-516	5/16	5
		VG-223Q-05-25-38	3/8	5



211

Post Brackets

This stainless steel bracket offers a clean, finished look while firmly holding guide rails in place. Post Brackets can be used alone or in combination with VG-205 or VG-245 angle brackets.

Available options:

- 2-1/2 or 3-1/2 inch height
- With or without positioning tabs
- 1/2, 5/8, or 3/4 inch pilot holes

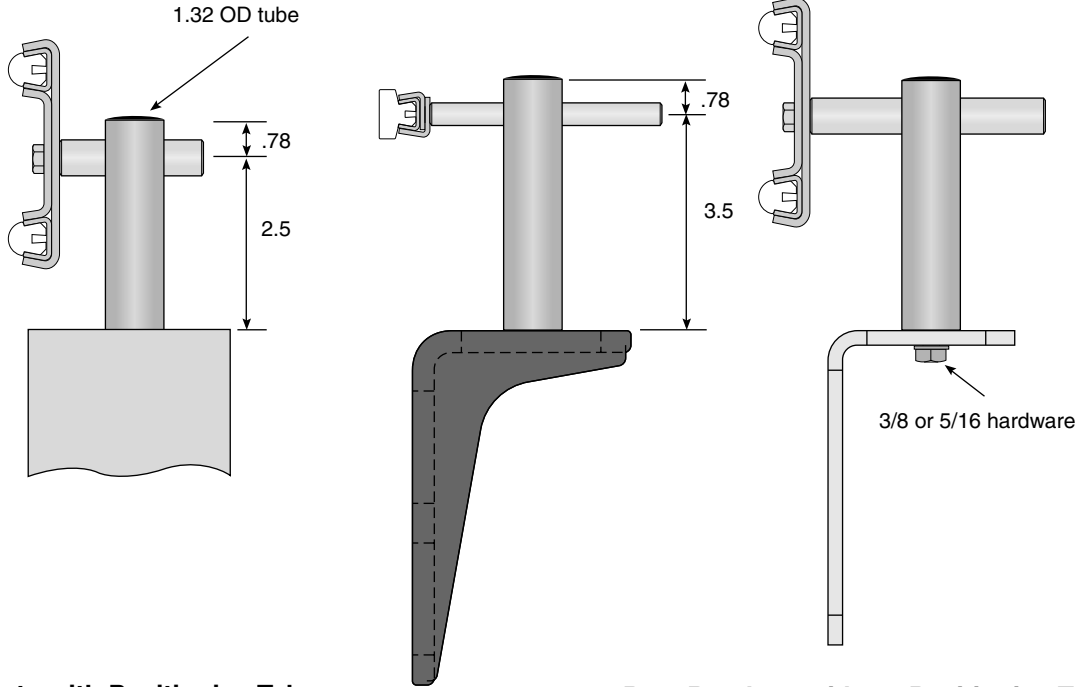

Post Brackets with Positioning Tabs

Tab/Hdw. Size	Pilot Hole (in.)	2.5 in. Height	3.5 in. Height
3/8	3/4	VG-211T3-25-34	VG-211T3-35-34
5/16	3/4	VG-211T5-25-34	VG-211T5-35-34
3/8	5/8	VG-211T3-25-58	VG-211T3-35-58
5/16	5/8	VG-211T5-25-58	
3/8	1/2	VG-211T3-25-12	VG-211T3-35-12
5/16	1/2		VG-211T5-35-12

Post Brackets without Positioning Tabs

Hdw. Size	Pilot Hole (in.)	2.5 in. Height	3.5 in. Height
3/8	3/4	VG-211-3-25-34	VG-211-3-35-34
5/16	3/4	VG-211-5-25-34	VG-211-5-35-34
3/8	5/8	VG-211-3-25-58	VG-211-3-35-58
5/16	5/8	VG-211-5-25-58	VG-211-5-35-58
3/8	1/2	VG-211-3-25-12	VG-211-3-35-12
5/16	1/2	VG-211-5-25-12	VG-211-5-35-12

Brackets & Positioning

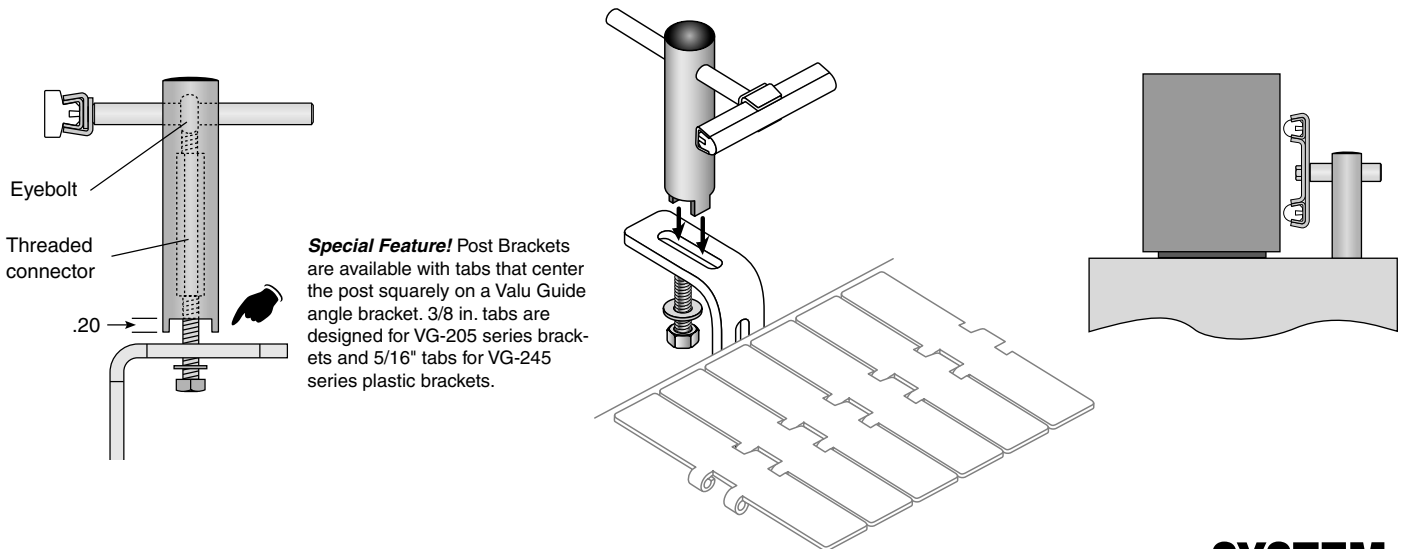



SpeedSet Post Brackets

211Q

SpeedSet Post Brackets

Combines the strength and appearance of post brackets with the innovative features of SpeedSet (page 298-300). SpeedSet Post Brackets can be used alone or in combination with VG-205 or VG-245 angle brackets.

(A)
Range of piston rod travel:
1, 1-1/2 or 2-1/2 inches

(B)
Sleeve length:
2, 3, or 5 inches

(C)
Bracket Height:
2.5 or 3.5 inches

(D)
Optional Positioning Tabs:
3/8 and 5/16 inches

(E)
Rod end tap:
3/8-16 or 5/16-18 inches

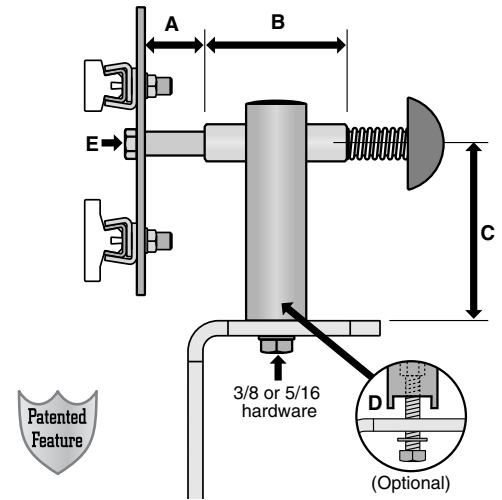

Collar

Positioning Spacer

Included with each SpeedSet post bracket is a single spacer that can accommodate 2 positioning lengths in addition to the "Home Position" by cutting as shown. Spacer length corresponds to the length of travel.

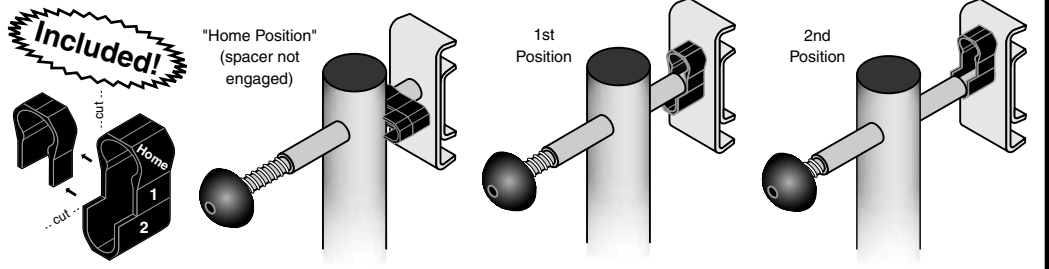

Brackets & Positioning



Adjustment Range (Travel), 0 thru 1½ inches

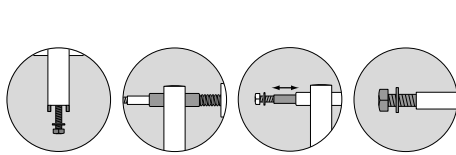
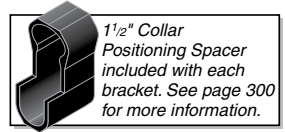
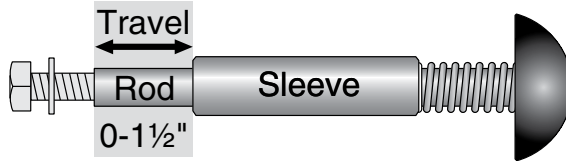

Tab/Hdw. Size (in.) Sleeve Length (in.) Travel (in.) Rod Tap (in.)

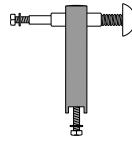

With Tabs
3.5 in. Height
Part Number

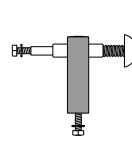

Without Tabs
2.5 in. Height
Part Number

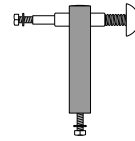

Without Tabs
3.5 in. Height
Part Number

3 inch sleeves

3/8	3	1.5	3/8			VG-211Q-3-35-03-15-38
3/8	3	1.5	5/16			VG-211Q-3-35-03-15-516
5/16	3	1.5	3/8	VG-211QT3-35-03-15-38	VG-211Q-5-25-03-15-38	
5/16	3	1.5	5/16	VG-211QT5-35-03-15-516	VG-211Q-5-25-03-15-516	VG-211Q-5-35-03-15-516

5 inch sleeves

3/8	5	1.5	3/8	VG-211QT3-35-05-15-38	VG-211Q-3-25-05-15-38	VG-211Q-3-35-05-15-38
3/8	5	1.5	5/16	VG-211QT3-35-05-15-516		VG-211Q-3-35-05-15-516
5/16	5	1.5	5/16	VG-211QT5-35-05-15-516	VG-211Q-5-25-05-15-516	VG-211Q-5-35-05-15-516

Adjustment Range (Travel), 0 thru 2½ inches

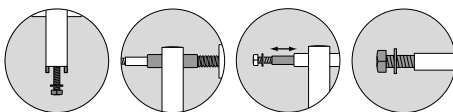
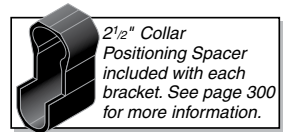
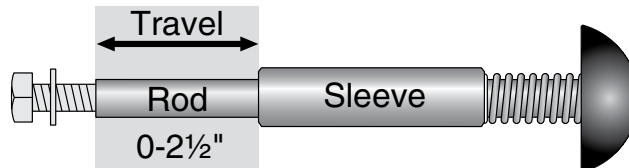

Tab/Hdw. Size (in.) Sleeve Length (in.) Travel (in.) Rod Tap (in.)

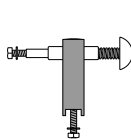

With Tabs
2.5 in. Height
Part Number

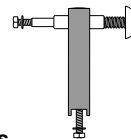

With Tabs
3.5 in. Height
Part Number

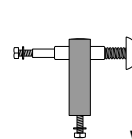

Without Tabs
2.5 in. Height
Part Number

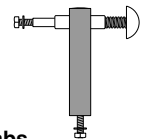

Without Tabs
3.5 in. Height
Part Number

5 inch sleeves

3/8	5	2.5	3/8		VG-211QT3-35-05-25-38	VG-211Q-3-25-05-25-38	VG-211Q-3-35-05-25-38
3/8	5	2.5	5/16	VG-211QT3-25-05-25-516	VG-211QT3-35-05-25-516	VG-211Q-3-25-05-25-516	VG-211Q-3-35-05-25-516
5/16	5	2.5	3/8	VG-211QT5-25-05-25-38	VG-211QT5-35-05-25-38		VG-211Q-5-35-05-25-38
5/16	5	2.5	5/16		VG-211QT5-35-05-25-516	VG-211Q-5-25-05-25-516	VG-211Q-5-35-05-25-516

Brackets & Positioning

SpeedSet Cartridges

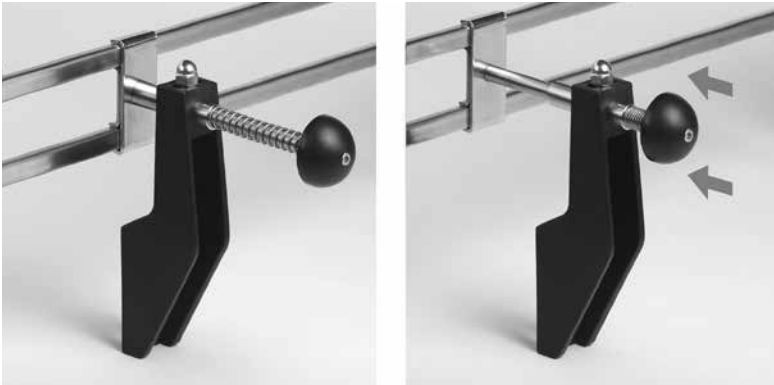

SpeedSet Cartridges

SpeedSet Cartridges solve conveyor line change problems... quickly. Use SpeedSet for preset conveyor guide rail adjustability that is fast and accurate without the need for tools. SpeedSet is fast because a simple push on the end knob moves the rod, clamp, and guide rail. SpeedSet is accurate due to the innovative positioning spacer design. Cartridges are available as part of bracket assemblies within this catalog, or choose from stand alone cartridges on this page. The SpeedSet Cartridge rod sleeve must be firmly held in position for proper operation.

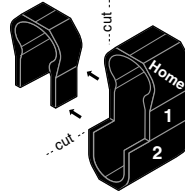
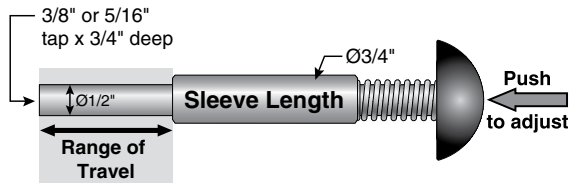

Included with each SpeedSet Cartridge!

Q-10

SpeedSet Cartridge, 0-1" Travel

Range of Travel	Sleeve Length	Tapped Rod Thread	Part Number
0-1"	2"	5/16	VG-Q-02-10-516
	3"	5/16	VG-Q-03-10-516
	5"	5/16	VG-Q-05-10-516
0-1.5"	3"	3/8	VG-Q-05-10-38
		5/16	VG-Q-03-15-516
	5"	3/8	VG-Q-03-15-38
0-2.5"	5"	5/16	VG-Q-05-15-516
		3/8	VG-Q-05-15-38
	2 1/2"	5/16	VG-Q-05-25-516
		3/8	VG-Q-05-25-38

Q-15

SpeedSet Cartridge, 0-1.5" Travel

Q-25

SpeedSet Cartridge, 0-2.5" Travel



SYSTEM PLAST™

Individual Metal "L" Brackets

205-A

Long
Angle Bracket
(Double Slot)

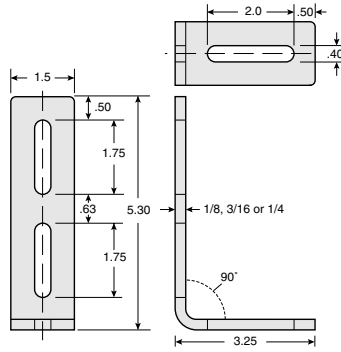

Material: Bracket is zinc plated or polished stainless steel.

Part Number	Stainless	Plated	Thickness
VG-205-A-18-P		•	1/8
VG-205-A-18-S	•		1/8
VG-205-A-316-P		•	3/16
VG-205-A-316-S	•		3/16
VG-205-A-14-P		•	1/4
VG-205-A-14-S	•		1/4

205-B

Standard
Angle Bracket

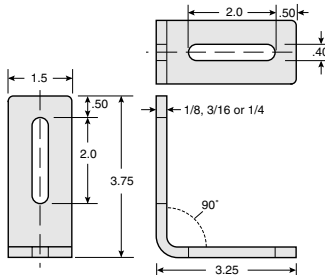

Part Number	Stainless	Plated	Thickness
VG-205-B-18-P		•	1/8
VG-205-B-18-S	•		1/8
VG-205-B-316-P		•	3/16
VG-205-B-316-S	•		3/16
VG-205-B-14-P		•	1/4
VG-205-B-14-S	•		1/4

205-C

Gusseted
Angle Bracket

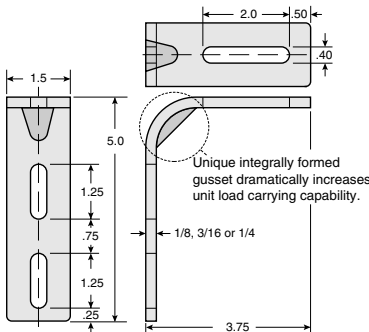
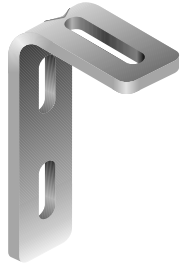

Part Number	Stainless	Plated	Thickness
VG-205-C-18-P		•	1/8
VG-205-C-316-P		•	3/16
VG-205-C-316-S	•		3/16
VG-205-C-14-P		•	1/4
VG-205-C-14-S	•		1/4

205-D

Long
Angle Bracket
(Single slot)

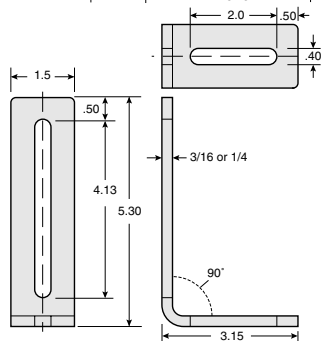

Part Number	Stainless	Plated	Thickness
VG-205-D-316-P		•	3/16
VG-205-D-316-S	•		3/16
VG-205-D-14-P		•	1/4
VG-205-D-14-S	•		1/4

205-E

Long
Angle Bracket
(Double slot)

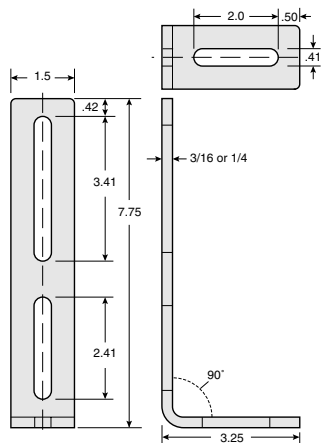

Part Number	Stainless	Plated	Thickness
VG-205-E-316-P		•	3/16
VG-205-E-316-S	•		3/16
VG-205-E-14-P		•	1/4
VG-205-E-14-S	•		1/4

Matches 8" and 10" bead guide bolt hole patterns

Brackets & Positioning

Note: Dimensions shown are nominal for 1/4 inch thick brackets.

Metal "L" Bracket Assemblies

Metal "L" Brackets

Adjustable metal bracket that fits most every application and cost requirement. Available in five different styles each with various metal thicknesses for light to heavy duty needs. The taller top angle, with single or double slots, provides increased rail adjustability. The 3 inch high VG-205-B may be used as a lower cost base angle or as a top angle where a shorter range of height adjustability is acceptable.

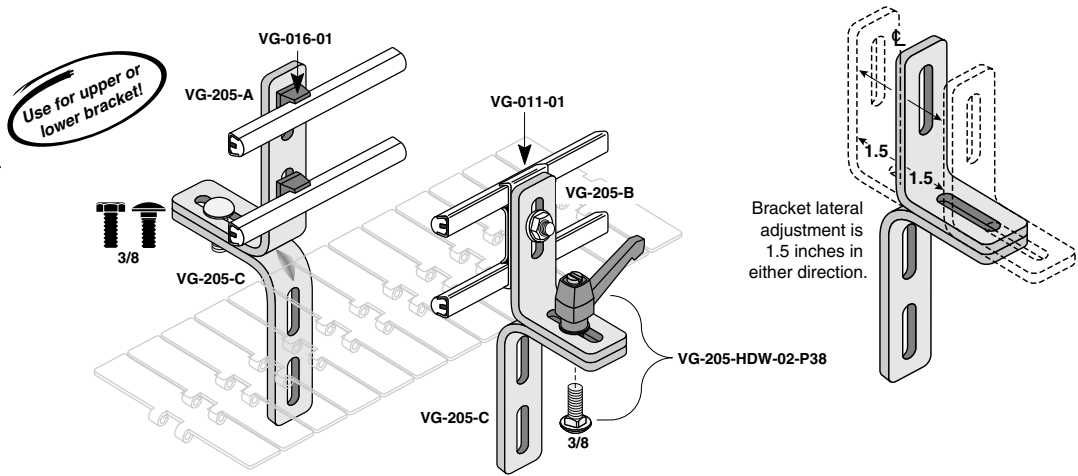

Standard Metal "L" Bracket Assemblies

All bracket assemblies include appropriate VG-205-HDW-03 hardware assembly.

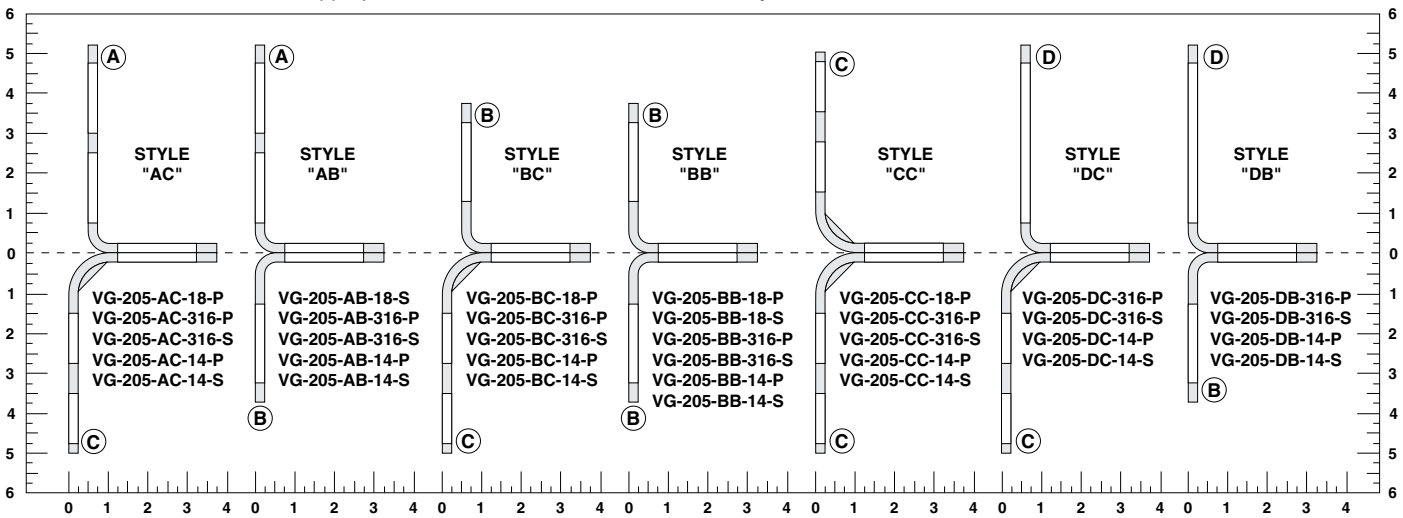

To order: Determine the style required from the chart above then select the part number based on the material type and thickness. Example: VG-205-AB-316-P = A top / B bottom, 3/16 inch thick material, zinc plated.

This hardware kit is included with 205 Bracket Assemblies shown above.

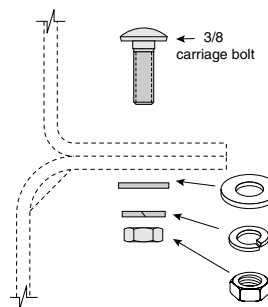
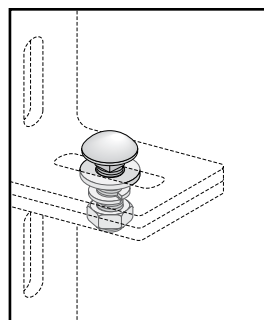

Part Number	Material
VG-205-HDW-03-P38	P
VG-205-HDW-03-S38	S

Optional Hardware Kit

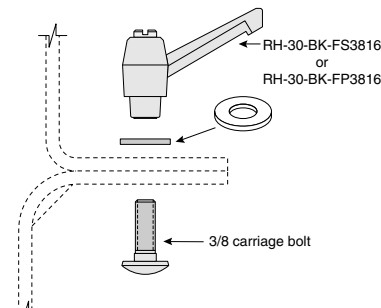
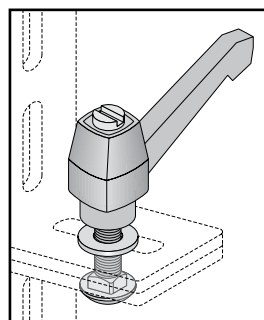

Part Number	Material
VG-205-HDW-02-P38	P
VG-205-HDW-02-S38	S



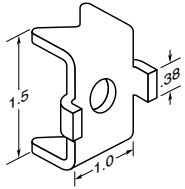

641T

Rod Mounts

Used for conveyor lane dividing applications or other rod adjustment situations. Positioning tabs lock the rod to bracket slots at 90°.

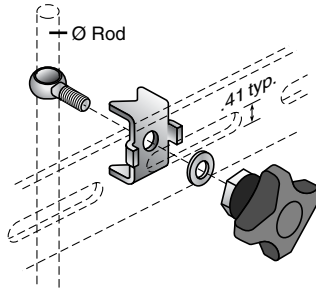

Material: Stainless steel.
Black nylon knob.

Part Number	Ø Rod
VG-641T-K-12	1/2
VG-641T-K-58	5/8
VG-641T-K-34	*3/4

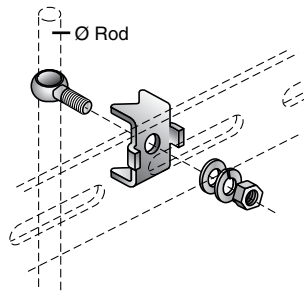

Material: Stainless steel.
Stainless steel hardware.

Part Number	Ø Rod
VG-641T-N-12	1/2
VG-641T-N-58	5/8
VG-641T-N-34	*3/4

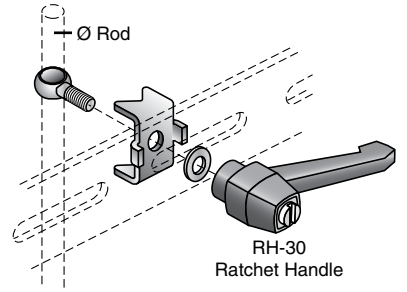

Material: Stainless steel.
Black nylon ratchet handle.

Part Number	Ø Rod
VG-641T-R-12	1/2
VG-641T-R-58	5/8
VG-641T-R-34	*3/4

* Ø3/4 versions can be converted to SpeedSet brackets.

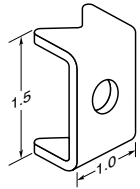

641

Rod Mounts

Used for conveyor lane dividing applications or other rod adjustment situations. Rod can be rotated to any angle desired.

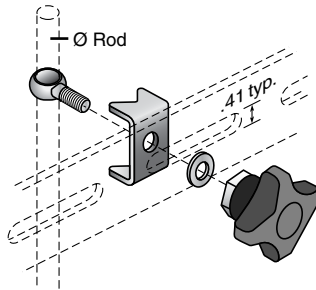

Material: Stainless steel.
Black nylon knob.

Part Number	Ø Rod
VG-641-K-12	1/2
VG-641-K-58	5/8
VG-641-K-34	*3/4

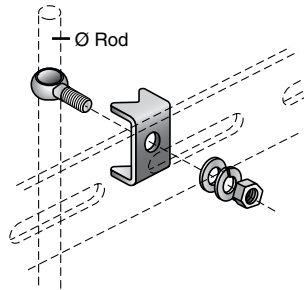

Material: Stainless steel.
Stainless steel hardware.

Part Number	Ø Rod
VG-641-N-12	1/2
VG-641-N-58	5/8
VG-641-N-34	*3/4

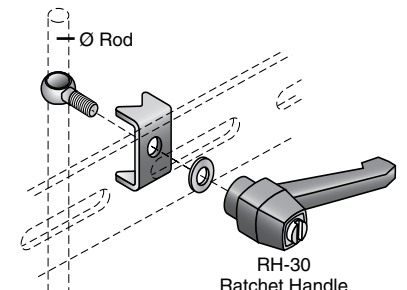

Material: Stainless steel.
Black nylon ratchet handle.

Part Number	Ø Rod
VG-641-R-12	1/2
VG-641-R-58	5/8
VG-641-R-34	*3/4

* Ø3/4 versions can be converted to SpeedSet brackets.

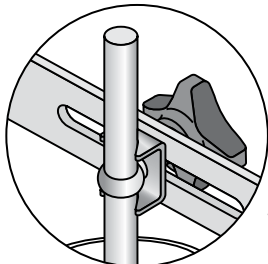
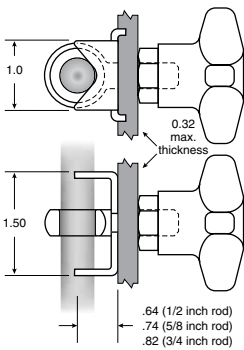

VG-641-K-
(without tabs)

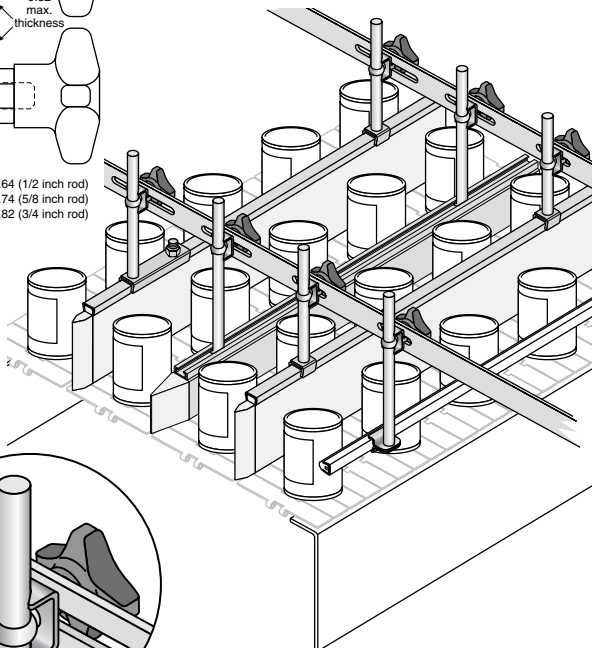

VG-641T-K-
(with tabs)

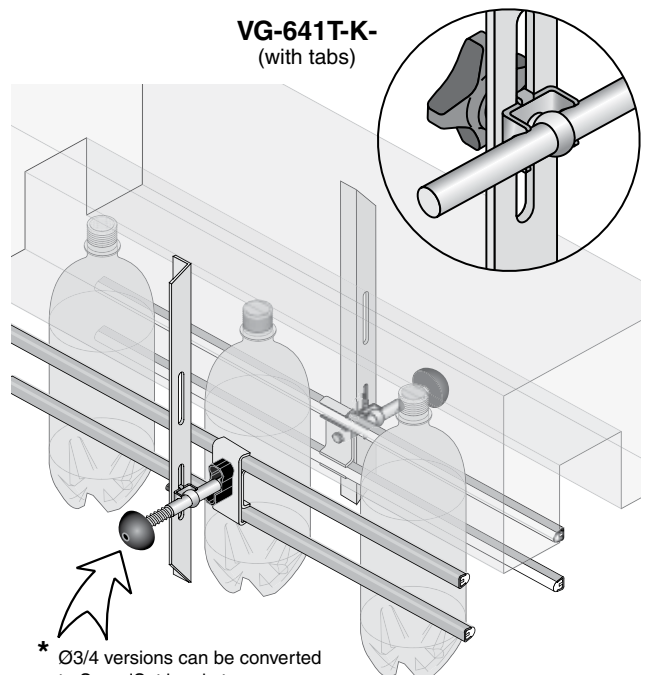

* Ø3/4 versions can be converted to SpeedSet brackets.

Brackets & Positioning

Fixed Guide Rail Brackets and Support Bars

201

Fixed Guide Rail Bracket

Material: Bracket is zinc plated or 12 gauge stainless steel.

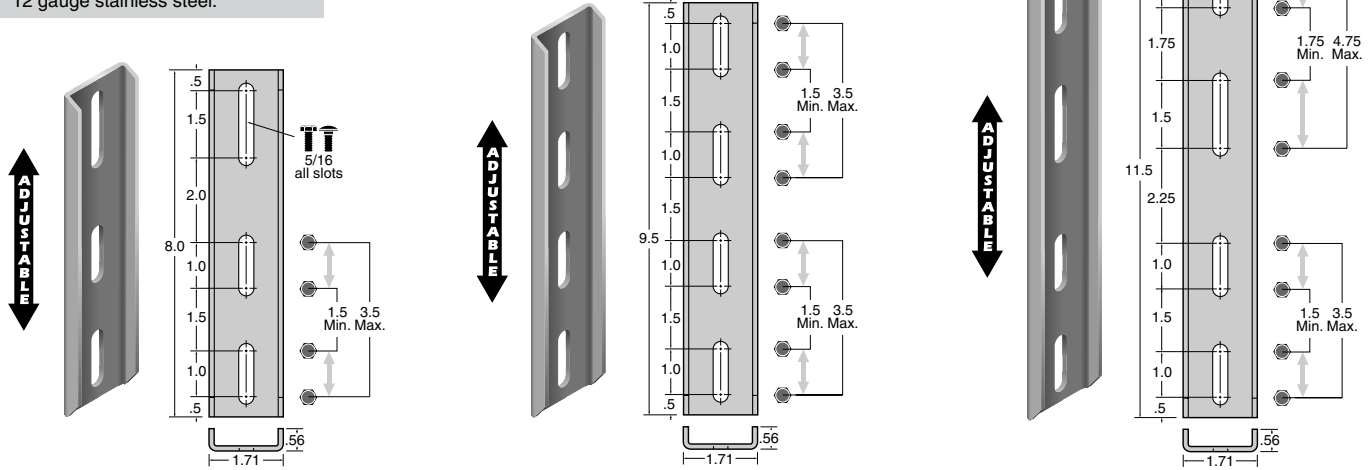

Part Number	Stainless	Plated	Length
VG-201-P08		•	8
VG-201-S08	•		8

Part Number	Stainless	Plated	Length
VG-201-P095		•	9.5
VG-201-S095	•		9.5

Part Number	Stainless	Plated	Length
VG-201-P115		•	11.5
VG-201-S115	•		11.5

204

Adjustable Support Bar

Support for guide rail. The new 204-D series support bar features an extended slot for greater adjustability.

Material: Bracket is zinc plated or polished stainless steel.

Brackets & Positioning

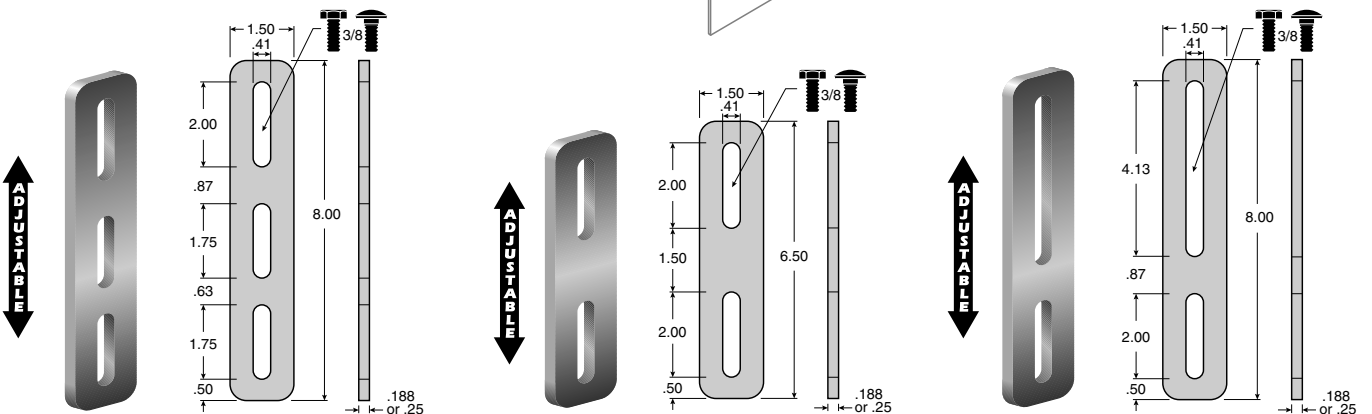
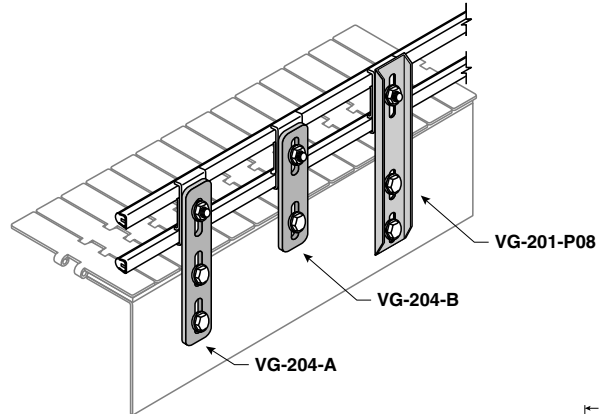

Part Number	Stainless	Plated	Thickness	Length
VG-204-A316-P		•	3/16	8
VG-204-A316-S	•		3/16	8
VG-204-A14-P		•	1/4	8
VG-204-A14-S	•		1/4	8

Part Number	Stainless	Plated	Thickness	Length
VG-204-B316-P		•	3/16	6.5
VG-204-B316-S	•		3/16	6.5
VG-204-B14-P		•	1/4	6.5
VG-204-B14-S	•		1/4	6.5

Part Number	Stainless	Plated	Thickness	Length
VG-204-D316-P		•	3/16	8
VG-204-D316-S	•		3/16	8
VG-204-D14-P		•	1/4	8
VG-204-D14-S	•		1/4	8



13809

Fixed Side Guide Bracket

For supporting side guides.

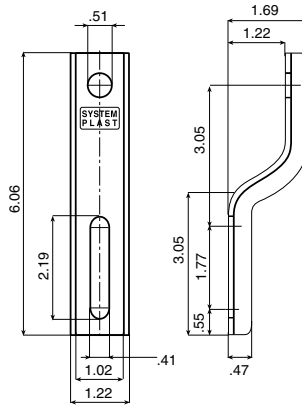

Material: Stainless steel.

Part Number

13809

204F

Mounting Bar

Versatile and time saving mounting bar positions guide rail. Can be used independently or in combination with various Valu Guide components.

3/8 carriage bolt and washer are included.

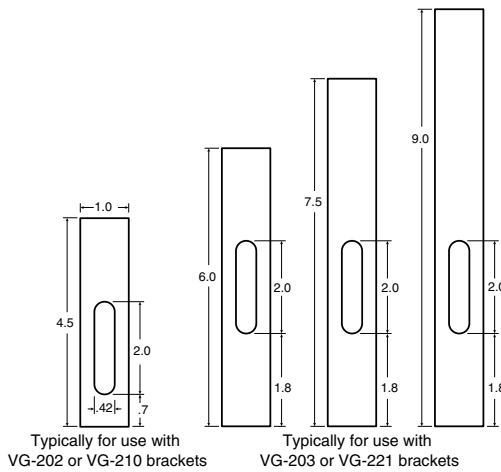
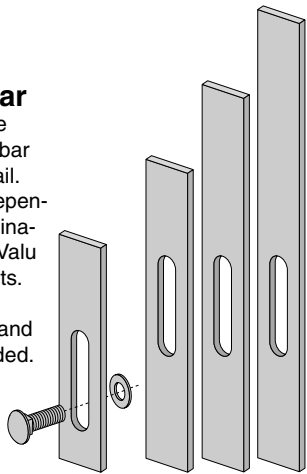

Material: Stainless steel, 3/16 x 1 inch.

Part Number

Length

VG-204F-45-316S

4.5

VG-204F-60-316S

6.0

VG-204F-75-316S

7.5

VG-204F-90-316S

9.0

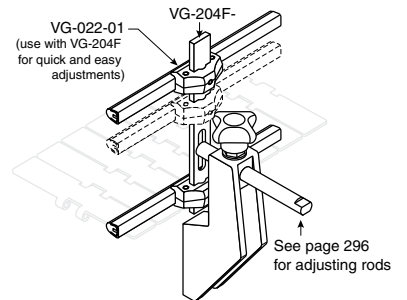

See page 296 for adjusting rods

200

Adjusting Rod Protective Caps

Can be used on all VG-020, VG-212 and VG-232 adjusting rods.

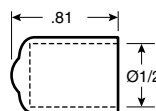

VG-200-4

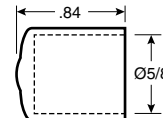

VG-200-5

Material: Yellow (Y) or red (R) PVC.

Part Number

Color

Ø Rod

VG-200-4Y

Y

1/2

VG-200-4R

R

1/2

VG-200-5Y

Y

5/8

VG-200-5R

R

5/8

200-225

Safety Cap

Provides personnel protection from exposed rod ends.

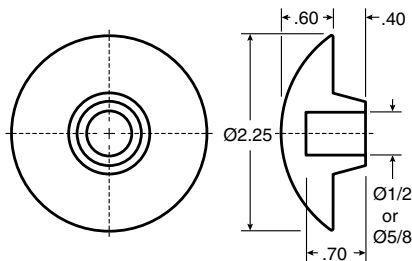
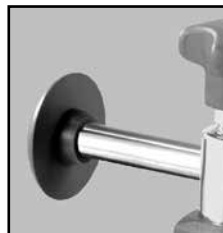

Material: Black rubber.

Part Number

Ø Rod

VG-200-225-12-B

1/2

VG-200-225-58-B

5/8

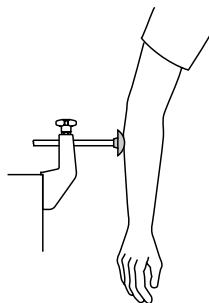
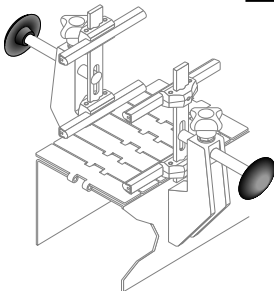

Brackets & Positioning



Drip Pan Holders

System Plast introduces a complete line of Drip Pan Holders in a variety of configurations to accommodate most applications. Made of stainless steel and polyamide, these components are fully adjustable corrosion resistant.

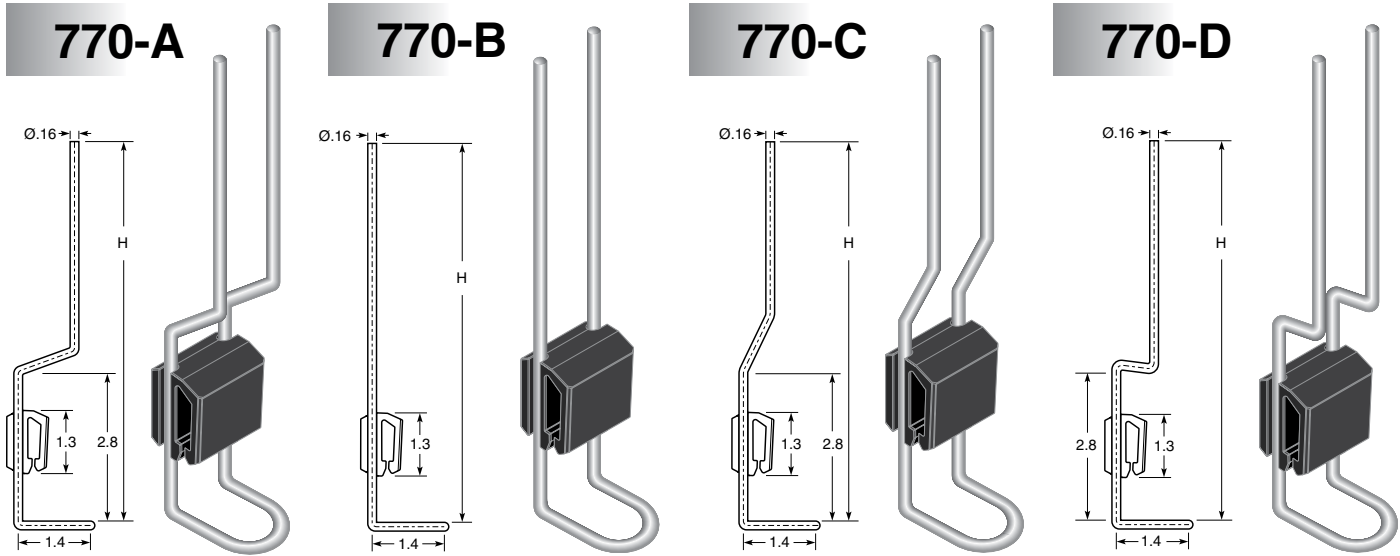

Material: Polyamide spacer block with stainless steel wire holder.

Part Number	H (in.)	Part Number	H (in.)	Part Number	H (in.)	Part Number	H (in.)
VG-770-A-L250	10	VG-770-B-L250	10	VG-770-C-L180	7	VG-770-D-L180	7
VG-770-A-L300	12			VG-770-C-L250	10	VG-770-D-L300	12

Brackets & Positioning

771

Drip Pan Mounting Washer

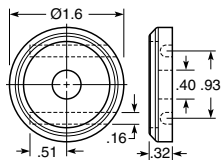

Material: Polyamide plate with stainless steel washer.

Part Number
VG-771-M10

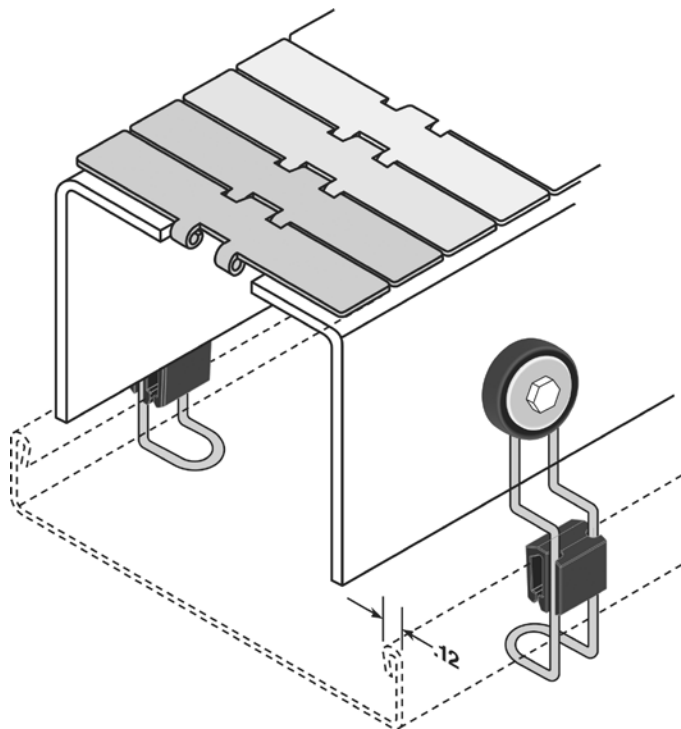

Heavy Duty Cross Blocks



Valu Guide 621 series heavy duty cross blocks firmly hold two rods at 90°. When adjustment is necessary, a simple turn of the hand knob loosens the cross block's grip on the rod. When the adjustment is complete, retighten the hand knob to lock the new position in place. These heavy duty cross blocks are manufactured from corrosion resistant polyamide with stainless steel hardware which provide superior strength and rigidity.

The unique design of the 621 series cross blocks does not rely on set screws that can score and mar adjusting rods and subsequently hinder movement. Instead, we use an eyelet which firmly clamps around the adjusting rod for superior holding strength. Independent rod adjustment makes the 621 series easy to work with. Knob versions do not require any tools for adjustment. Variations on the cross block design include optional lock washer and nut tightening, stainless steel body designs, and 45° cross rod angles.

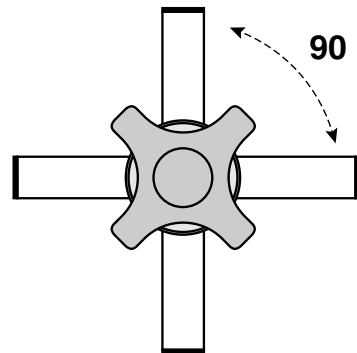
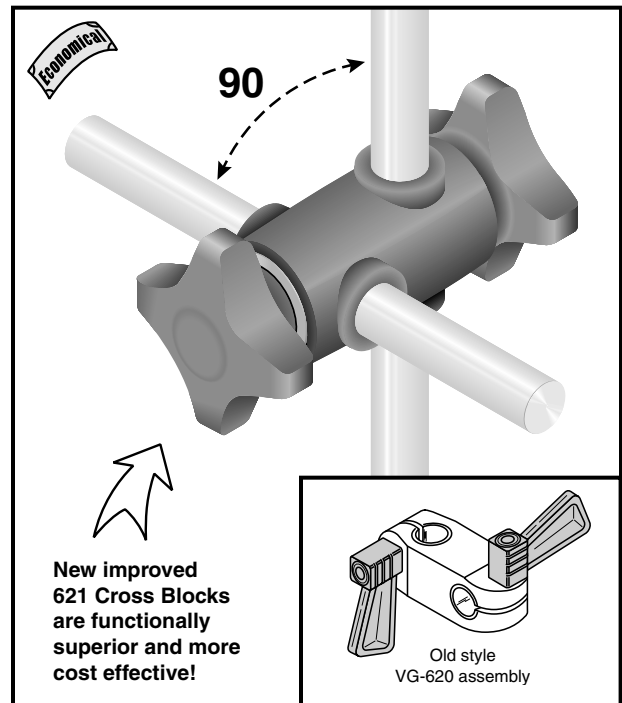
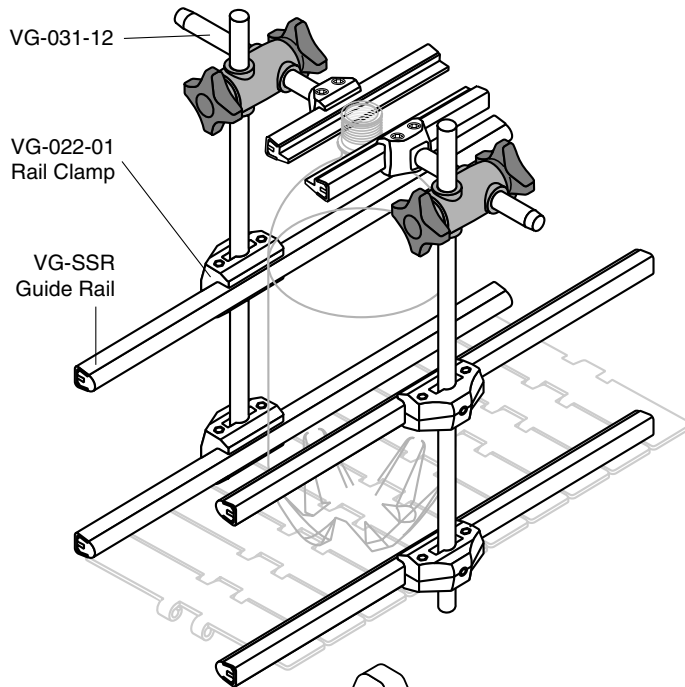

Brackets & Positioning

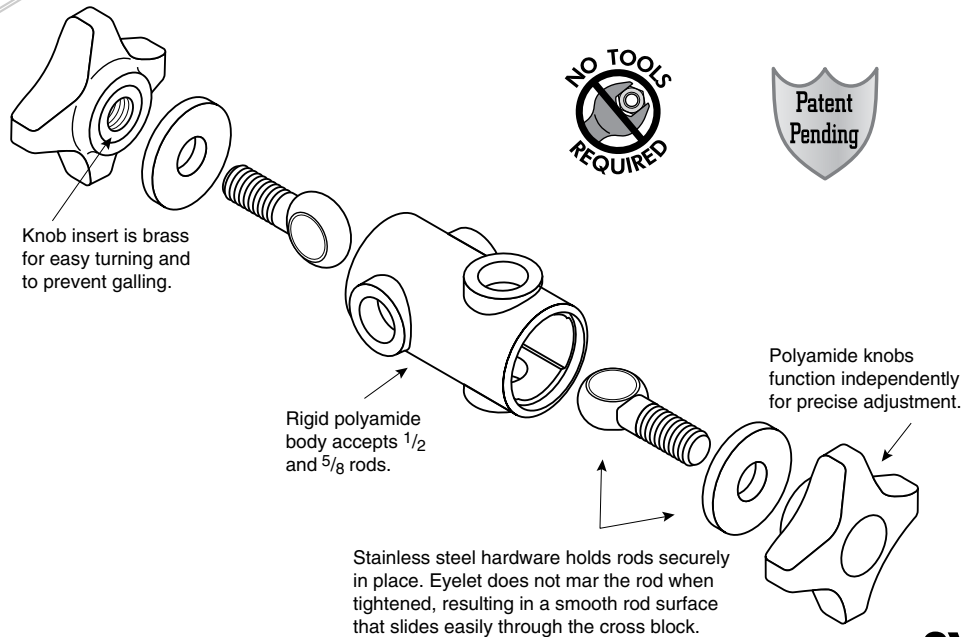

SYSTEM PLAST™



Heavy Duty Cross Blocks

621 series

Cross Blocks

Connects two round rods at 90°. Versions available to hold Ø1/2 and Ø5/8 inch rods. Standard VG-621 cross blocks come with hand knobs on each side for quick adjustment.

VG-621NK features a hand knob on one side and a nut with lock washer on the other side. The hand knob side is ideal for frequent adjustments while the lock washer and nut side is suited to more permanent positioning.

VG-621NN is supplied with lock washers and nuts on both sides for holding rods in place when less frequent adjustments are necessary. Rods not included.

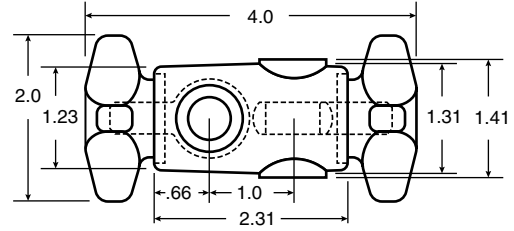
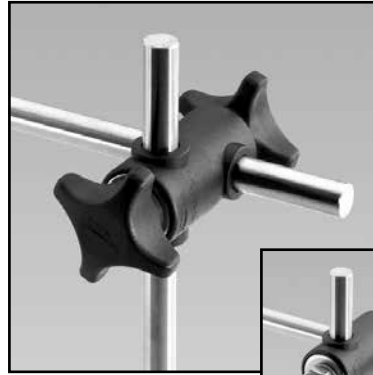

Material: Polyamide body and knobs with brass inserts. Stainless steel hardware.

Part Number with 2 Knobs	Part Number with 1 Knob and 1 Nut	Part Number with 2 Nuts	Ø Rod	X	Ø Rod
VG-621-12-12	VG-621NK-12-12	VG-621NN-12-12	1/2		1/2
VG-621-12-58	VG-621NK-12-58	VG-621NN-12-58	1/2		5/8
VG-621-58-58	VG-621NK-58-58	VG-621NN-58-58	5/8		5/8

621S series

Stainless Steel Cross Blocks

VG-621S series connects two round rods at 90°. VG-621S-45 series connects two round rods at 45°. Versions available to hold Ø1/2, Ø5/8, and Ø3/4 inch rods. Standard cross blocks come with hand knobs on each side for quick adjustment.

NK designated part numbers feature a hand knob on one side and a nut with lock washer on the other side. The hand knob side is ideal for frequent adjustments while the lock washer and nut side is suited to more permanent positioning.

NN designated part numbers are supplied with lock washers and nuts on both sides for holding rods in place when less frequent adjustments are necessary. NN versions of VG-621S series cross blocks are completely stainless steel. Rods not included.

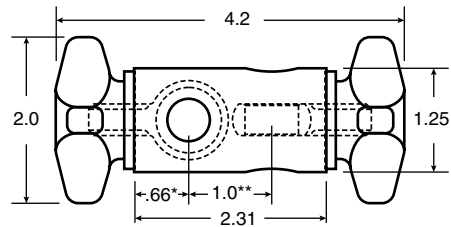
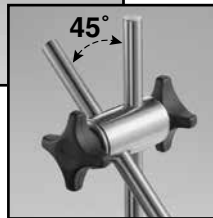
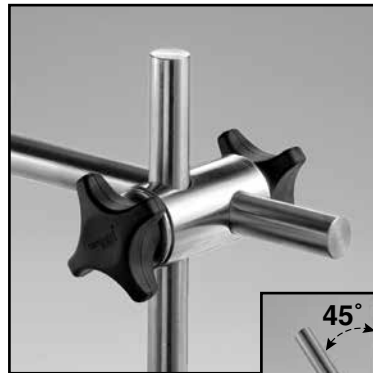
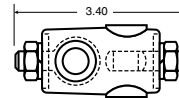
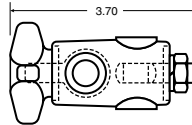

*.60 and **1.13 for 5/8 x 3/4 and 3/4 x 3/4 cross blocks

All Stainless Hi-Temp

Material: Stainless steel body, polyamide knobs with brass inserts. Stainless steel hardware.

Part Number with 2 Knobs	Part Number with 1 Knob and 1 Nut	Part Number with 2 Nuts	Part Number with 2 Knobs, 45°	Part Number with 2 Nuts, 45°	Ø Rod	X	Ø Rod
VG-621S-12-12	VG-621SNK-12-12	VG-621SNN-12-12	VG-621S-45-12-12R	VG-621SNN-45-12-12R	1/2		1/2
VG-621S-12-58	VG-621SNK-12-58	VG-621SNN-12-58	VG-621S-45-12-58R	-	1/2		5/8
VG-621S-58-58	VG-621SNK-58-58	VG-621SNN-58-58	VG-621S-45-58-58R	-	5/8		5/8
VG-621S-12-34	VG-621SNK-12-34	VG-621SNN-12-34	-	-	1/2		3/4
VG-621S-58-34	VG-621SNK-58-34	VG-621SNN-58-34	-	-	5/8		3/4
VG-621S-34-34	VG-621SNK-34-34	VG-621SNN-34-34	-	-	3/4		3/4

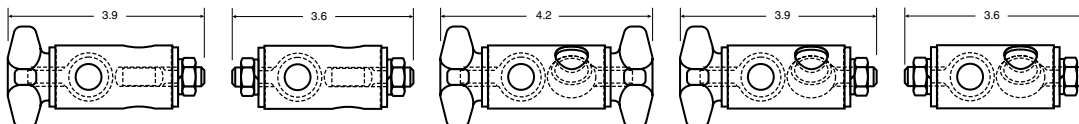

Brackets & Positioning

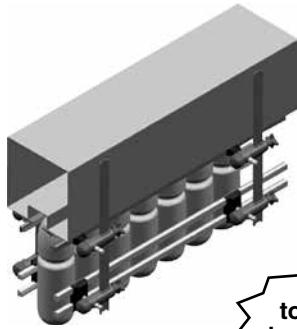

- Rapid and precise adjustments of guides to accommodate various bottle sizes.
- Fits 1/2" inch. diameter adjusting rods.
- Corrosion resistance composite components.
- Ergonomic spring loaded design.
- Quick and easy maintenance.



Twist to lock, twist back to unlock

33313

Quick Adjust Cross Blocks

Dual action cross blocks firmly hold two rods at 90°. When adjustment is necessary, a simple turn of the quick release cap loosens the cross block's grip on the rod. When the adjustment is complete, retighten the cap to lock the new position in place.

Requires custom grooved rod. Not included.

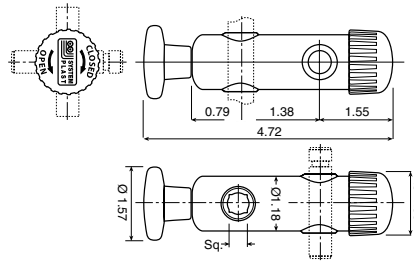

Material: Polyamide body, cap, and knob. Knob has stainless steel insert. Cap has nickel plated brass insert.

Part Number	Ø Rod (in.)	Ø Rod (in.)	Sq.
33313	1/2	1/2	7/16

1/2 round or 7/16 square rod

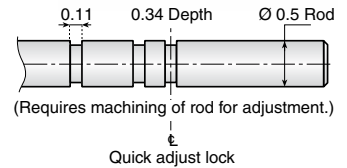

33262

Quick Adjust Cross Blocks

Dual action cross blocks firmly hold a rod and flat bar at 90°. When adjustment is necessary, a simple turn of the quick release cap loosens the cross block's grip on the rod. When the adjustment is complete, retighten the cap to lock the new position in place.

Requires custom grooved rod and flat bar. Not included.

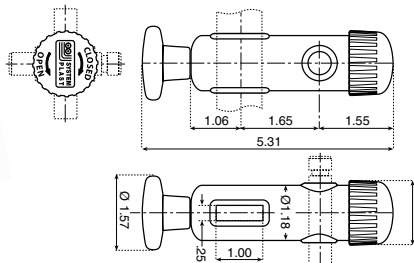

Material: Polyamide body, cap, and knob. Knob has stainless steel insert. Cap has nickel plated brass insert.

Part Number	Ø Rod (in.)	Flat bar (in.)
33262	1/2	1 x 1/4

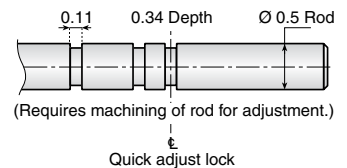
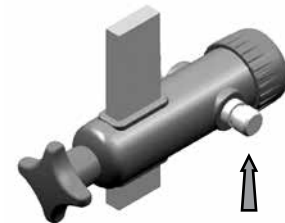

Brackets & Positioning

13182

LIGHT DUTY

Cross Blocks

Economically connects two round rods at 90°. Cross blocks come with hand knobs on each side for quick adjustment.

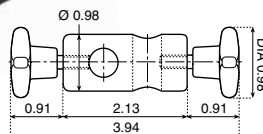

Material: Polyamide body and knobs. Knobs have stainless steel insert.

Part Number	Ø Rod (in.)
13182	1/2



Standard Cross Blocks

620

Rod to Rod Cross Block

Connects two round rods at 90°.

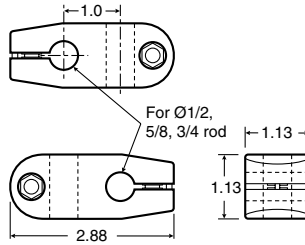

Material: Reinforced acetal with stainless steel bolt and nickel plated brass nut.

Part Number	Ø Rod	X	Ø Rod
VG-620-12-12	1/2		1/2
VG-620-12-58	1/2		5/8
VG-620-58-58	5/8		5/8
VG-620-34-34	3/4		3/4

620-12SQ

Rod to Square Rod Cross Block

Connects one round rod and one square rod at 90°.

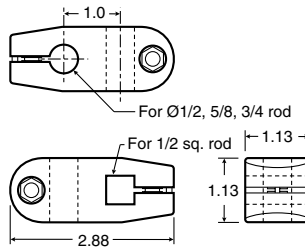

Part Number	Sq. Rod	X	Ø Rod
VG-620-12SQ-12	1/2		1/2
VG-620-12SQ-58	1/2		5/8
VG-620-12SQ-34	1/2		3/4

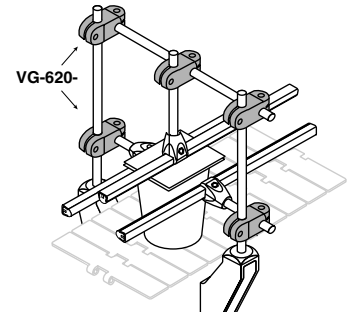

620-716HX

Rod to Hex Rod Cross Block

Connects one round rod and one hex rod at 90°.

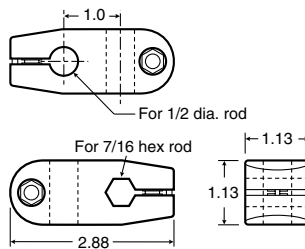

Part Number	Hex. Rod	X	Ø Rod
VG-620-716HX-12	7/16		1/2

Brackets & Positioning

619

Rod to Rod Cross Block

Connects one round rod and/or one square rod at 90°.

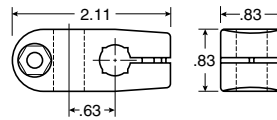

Accepts round rod or square rod!

Material: Reinforced acetal with stainless steel bolt and nickel plated brass nut.

Part Number	Support Ø Rod (mm)
VG-619-10M	10mm/8mm sq.
VG-619-12M	12mm/10mm sq.
VG-619-14M	14mm/12mm sq.

335 series

Lane Divider Cross Blocks

Typically used in a bridge over conveyors to support lane dividers. Rod not included. Max recommended tightening torque is 21.7 ft-lbs.

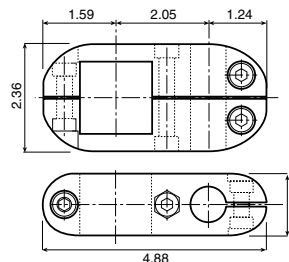

Material: Polyamide body with stainless steel hardware.

Part Number	Ø Rod	X	Ø Rod
33512	1-1/2		5/8
33509	1-1/2		3/4

Standard Cross Blocks, Ratchet Handle and Sensor Mount

300

Standard Cross Blocks

Connects two round or square rods at 90°. Rods not included.

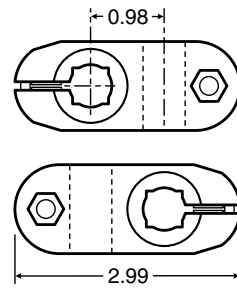
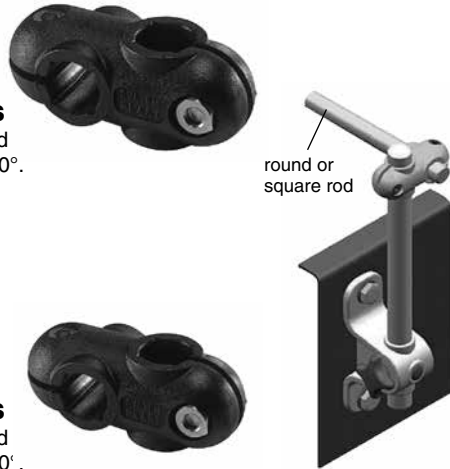

Material: Polyamide body with stainless steel fasteners.

Part Number	Ø Rod (in.)	Ø Rod X (in.)	Sq. Rod (in.)	Sq. Rod X (in.)
30001NV	1/2	1/2	7/16	7/16
30002NV	1/2	5/8	7/16	9/16
30003NV	5/8	5/8	9/16	9/16
30015NV	5/8	3/4	9/16	5/8
30016NV	3/4	3/4	5/8	5/8

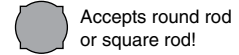

33151

Standard Cross Blocks

Connects two round or square rods at 90°. Rods not included.

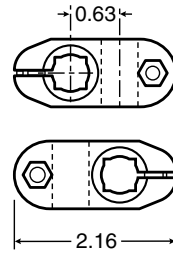

Material: Acetal body with stainless steel fasteners.

Part Number	Ø Rod (in.)	Ø Rod X (in.)	Sq. Rod (in.)	Sq. Rod X (in.)
33151	1/2	1/2	7/16	7/16

335HV

Lane Divider Cross Blocks with 2 Handles

For use in areas where frequent adjusting is required for horizontal and vertical movement.

Rod not included. Max recommended tightening torque is 21.7 ft-lbs.



Material: Polyamide body with stainless steel hardware. Polyamide handle with nickel plated brass insert.

Part Number	Ø Rod	X	Ø Rod
33512HV	1-1/2		5/8
33509HV	1-1/2		3/4

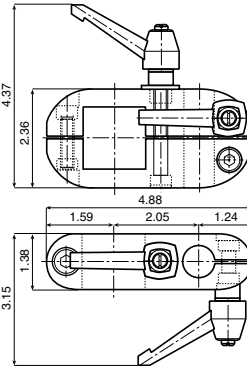

Brackets & Positioning

623

Ratchet Handle

Replaces fastener for easier adjustment. Used with VG-620 Cross Block. (Note: VG-621 Cross Blocks are functionally superior and more cost effective!)



See page 376 for additional ratchet handles.

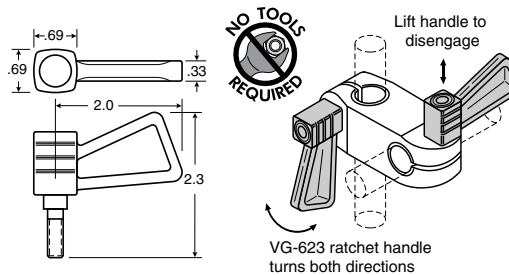

Material: Reinforced polyamide with stainless steel thread.

Part Number	Thread
VG-623-BK	1/4-20

612

Sensor Mount

Accurately positions sensors and reflectors. Use with VG-022-01 rail clamp for ideal sensor mounting and quick adjustment, above or below guide rail.

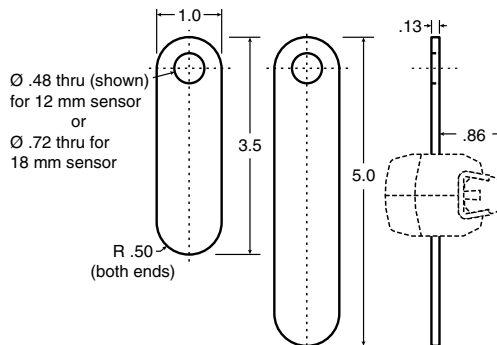
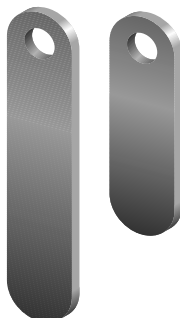

Material: Stainless steel.

Part Number	Length(in.)	Sensor(mm)
VG-612-35-12	3.5	12
VG-612-35-18	3.5	18
VG-612-50-12	5	12
VG-612-50-18	5	18

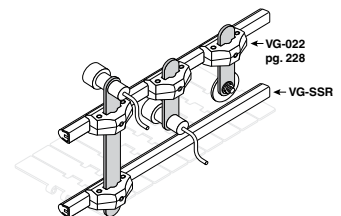



Accessory Holders

Universal Accessory Holders

Photocells, sensors, spray heads, miniature pneumatics, plus many other accessories can easily be held in place using accessory holders. These multi-axis assemblies are designed to offer unlimited possibilities for mounting accessories on conveyors and machinery of all types. Made of corrosion resistant thermoplastic and stainless steel, accessory holders can withstand harsh operating environments. Accessory holder assemblies are configured to hold either sensors or reflectors, and are available with Ø1/2 inch support rods. Each component is available individually.

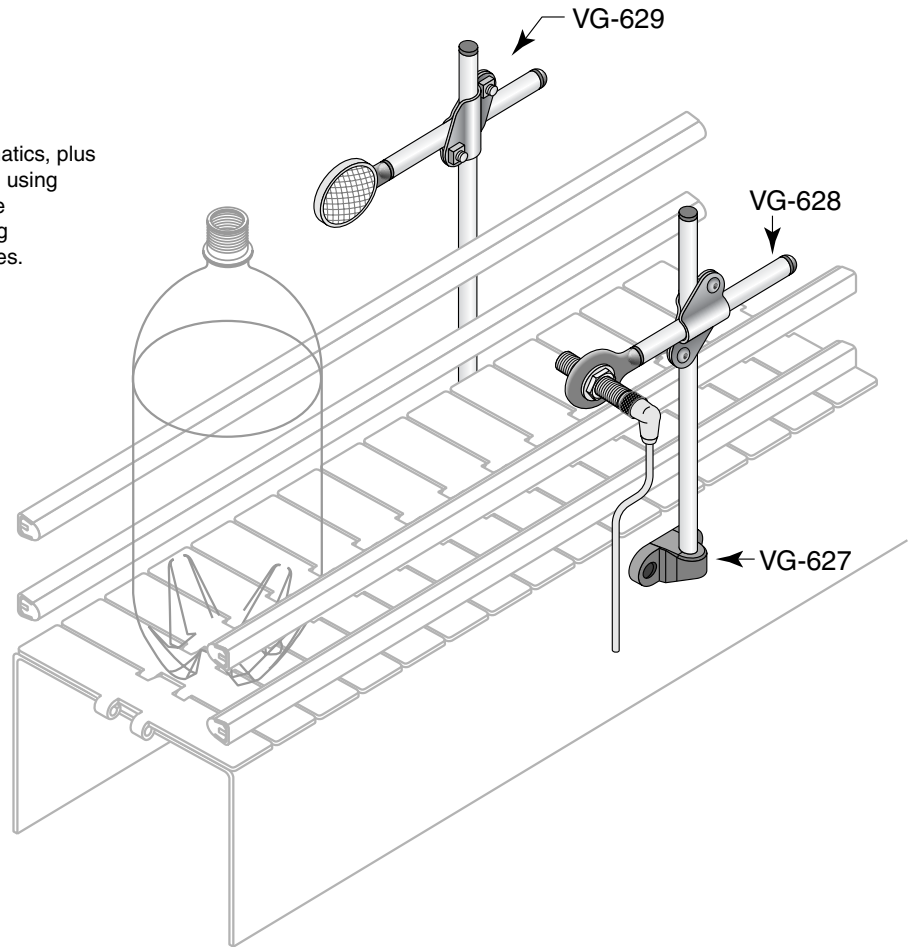

Brackets & Positioning

627

Molded T-Rod

Can be used as part of an accessory holding assembly, or as a light duty side mount bracket. Unique stainless steel and molded plastic design is strong, yet economical.

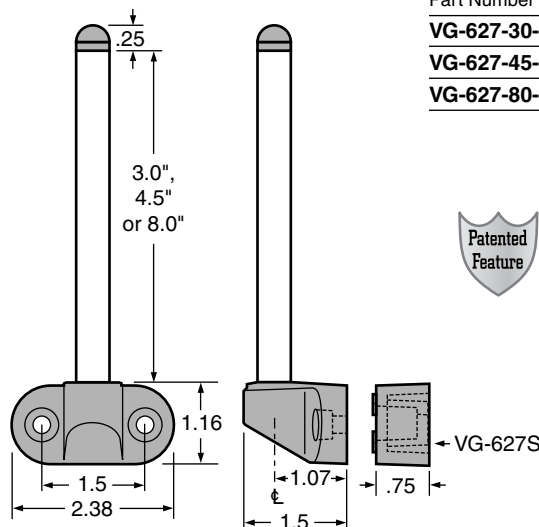
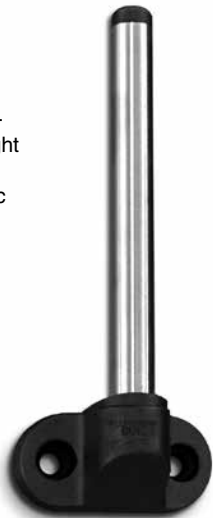

Material: Polyamide and stainless steel.

Part Number	Rod Length (in.)	Rod Ø (in.)
VG-627-30-12	3.0	1/2
VG-627-45-12	4.5	1/2
VG-627-80-12	8.0	1/2



Patent Numbers
6,427,829 B1
6,591,978

627S

T-Rod Offset Spacer

Plastic spacer is used to offset T-Rod from mounting surface. Multiples can be stacked.

Material: Polyamide.

Part Number	Thickness (in.)
VG-627S-34	3/4



628

Accessory Holder

This unique stainless steel and molded plastic design is a strong, yet economical method for holding many types of accessories. A variety of bore sizes are available.

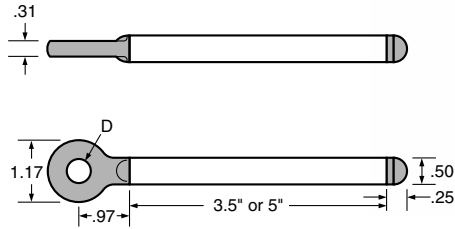

Material: Polyamide holder, stainless steel rod.

Part Number	Rod Length (in.)	Rod Ø (in.)	Accessory Hole Ø (D)
VG-628-35-12-14	3.5	1/2	.25
VG-628-35-12-38	3.5	1/2	.38
VG-628-35-12-12	3.5	1/2	.50
VG-628-35-12-34	3.5	1/2	.75
VG-628-50-12-14	5.0	1/2	.25
VG-628-50-12-38	5.0	1/2	.38
VG-628-50-12-12	5.0	1/2	.50
VG-628-50-12-58	5.0	1/2	.63
VG-628-50-12-34	5.0	1/2	.75

629

Cross Clamp

Stainless steel clamp used to connect two Ø1/2 inch round rods at 90°. Fastening hardware is included.

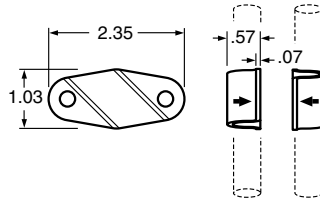
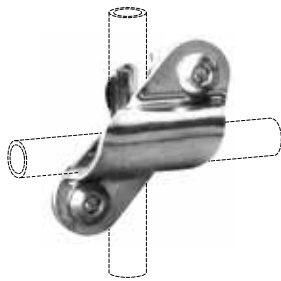

Material: Stainless steel.

Part Number	Rod Ø (in.)	X	Rod Ø (in.)
VG-629-12-12	1/2		1/2

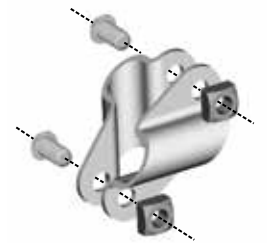

Brackets & Positioning

629R

Rotating Cross Clamp

Stainless steel clamp used to connect two Ø1/2 inch round rods at any angle. Fastening hardware is included.

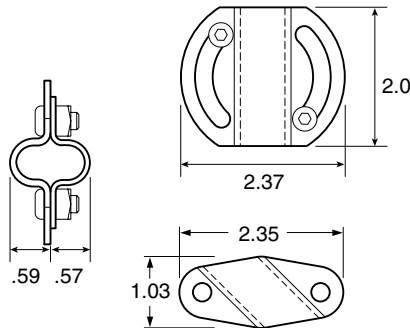
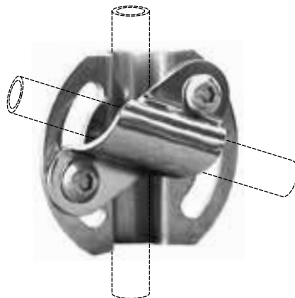

Material: Stainless steel.

Part Number	Rod Ø (in.)	X	Rod Ø (in.)
VG-629R-12-12	1/2		1/2

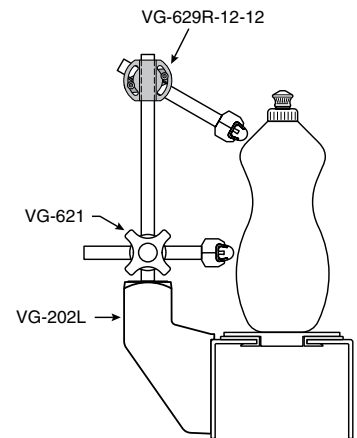
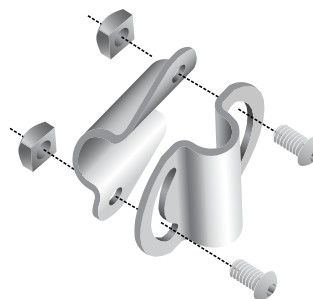
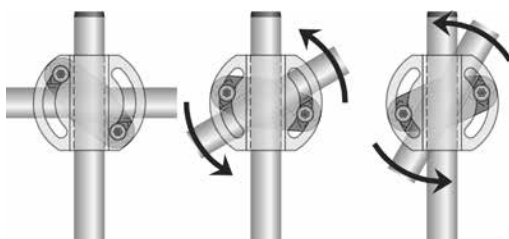



Mounts for Photocells or Reflectors

Material: Reinforced polyamide clamp with stainless steel bolt.

33616

Universal Mount for Photocells or Reflectors

Used to hold photocells or reflectors.

Max recommended tightening torque 14.4 ft-lbs.

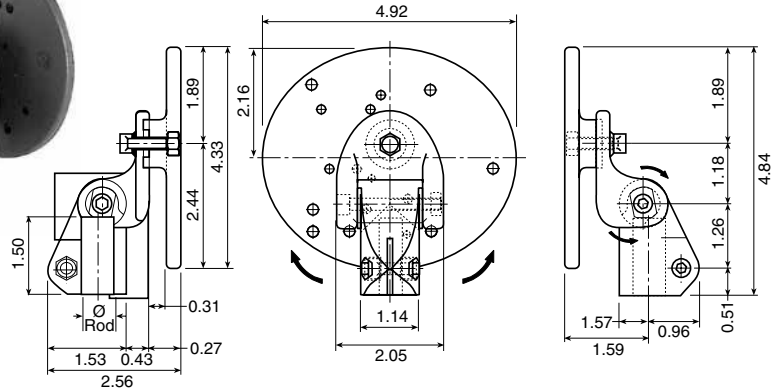

Part Number	Ø Rod (in.)
33616	1/2

Note: Photocells or Reflectors not included.

Suitable Photocell Types

Brackets & Positioning

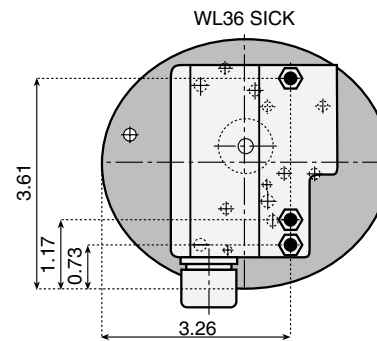
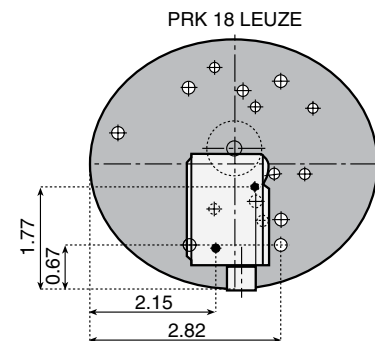
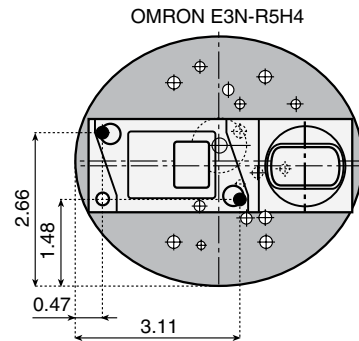
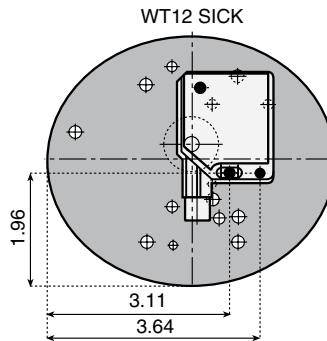
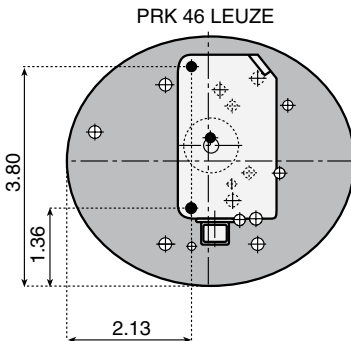
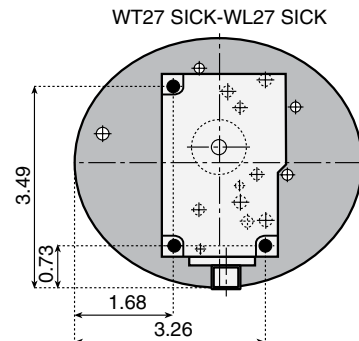
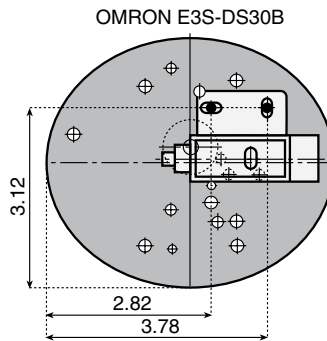
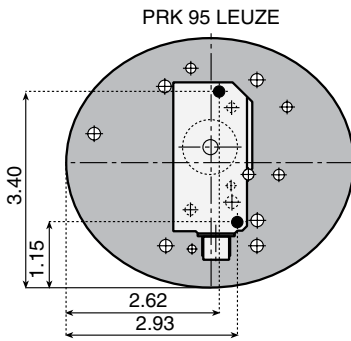



33500

Mount for Photocells or Reflectors

Used to hold photocells or reflectors.
Can be fitted in three different positions.

Material: Reinforced polyamide clamp with stainless steel bolts.

Part Number	Ø Rod (in.)
33500	1/2

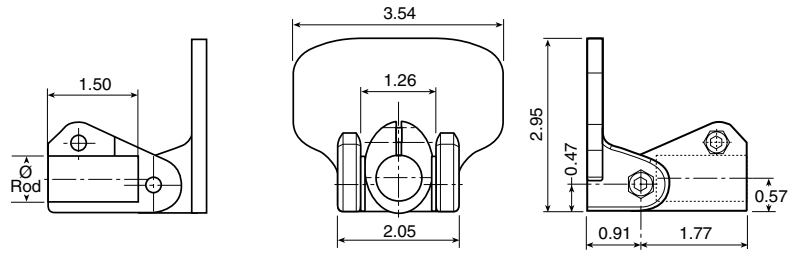
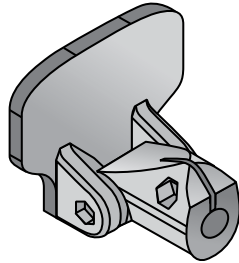

Note: Photocells or Reflectors not included.

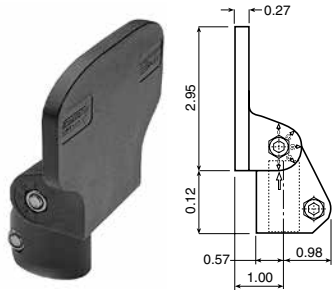

Position - A

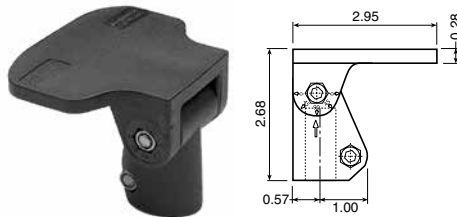

Position - B

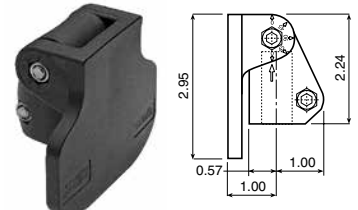

Position - C

13150

Bottle Indicator

Used to activate photocells on conveyors and machines.

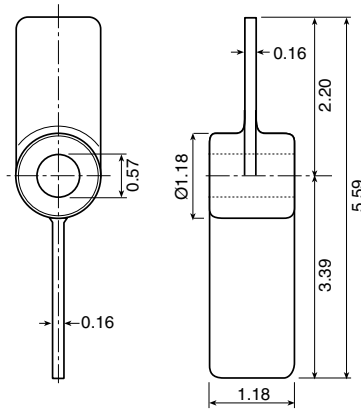

Material: Reinforced polyamide.

Part Number
13150

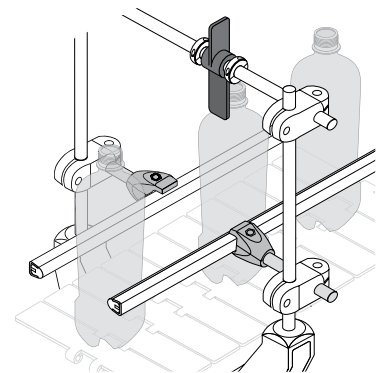

Brackets & Positioning

13149

Control Contact Lever

Used to activate photocells on conveyors and machines.

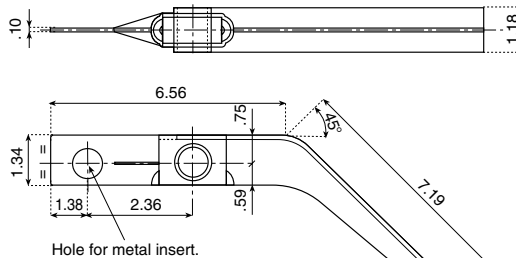
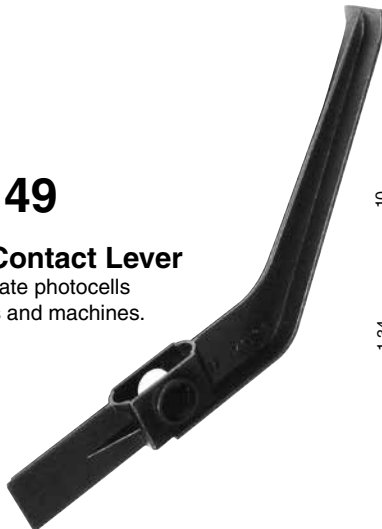

Material: Reinforced polyamide.

Part Number	
13149	with hole
13149SF	without hole



Accessory Mount Components for 1/2" Rod

614

Reflector Mount

Used to hold reflectors using a cap screw and nut or press-in clip onto Ø1/2 inch support rods.

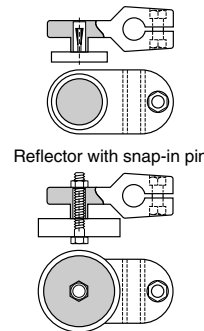
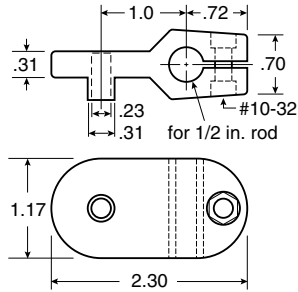

Reflector with bolt and nut

Material: Reinforced polyamide body with stainless steel fasteners.

Part Number	Ø Rod (in.)
VG-614-12	1/2

Note: Reflectors not included.

618

Accessory Holder

Used to hold many types of accessories onto Ø1/2 inch support rods. A variety of bore sizes are available.

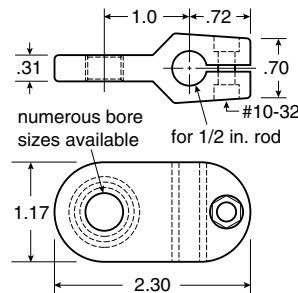

Material: Reinforced polyamide body with stainless steel fasteners.

Part Number (in.)	Support Ø Rod (in.)	Accessory Ø Bore
VG-618-12-14	1/2	1/4
VG-618-12-38	1/2	3/8
VG-618-12-12	1/2	1/2
VG-618-12-58	1/2	5/8
VG-618-12-34	1/2	3/4

617

T-Clamp

Mounts to side of equipment to provide support for light duty rod type guide rail systems. Part of the VG-615 series accessory holder assembly.

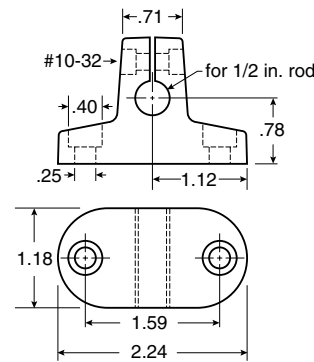

Material: Reinforced polyamide body with stainless steel fasteners.

Part Number	Ø Rod (in.)
VG-617-12	1/2

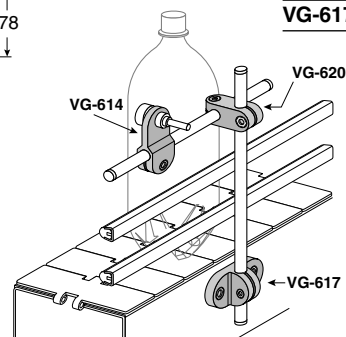

215

Support Rods

Available in three lengths, these rods can be used with accessory cross blocks, holders and clamps. They are made from 1/2 and 5/8 inch OD stainless steel tubing. The ends are capped with a black polyethylene plug.

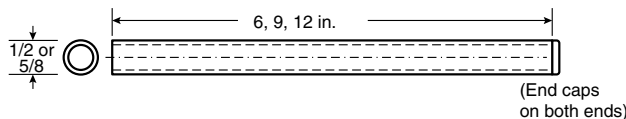
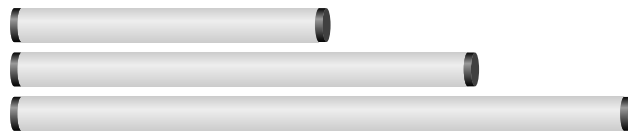

Material: Stainless steel tube. Black polyethylene end caps.

1/2" Part Number	5/8" Part Number	Length (in.)
VG-215-06-12T	VG-215-06-58T	6
VG-215-09-12T	VG-215-09-58T	9
VG-215-12-12T	VG-215-12-58T	12

SYSTEM PLAST™

©2015 Regal-Beloit Corporation, All Rights Reserved.



VG-615R-12 consists of the following parts:

615R

Reflector Mounting Assembly

The assembly for holding reflectors is available with $\text{\O}1/2$ inch support rods and corresponding attachments.

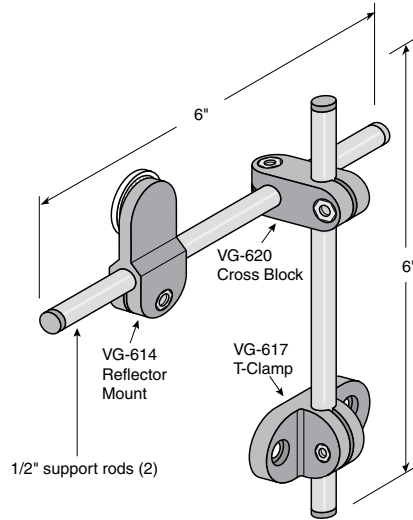

Material: Corrosion resistant thermoplastic parts with stainless steel fasteners. Stainless steel tubes with plastic insert caps.

Part Number	\O Support Rod (in.)
VG-615R-12	1/2

VG-615A-12- assemblies consist of the following parts:

615A

Sensor Mounting Assembly

The assembly for holding sensors is available with $\text{\O}1/2$ inch support rods and corresponding attachments. The accessory holder attachment is available in a variety of bore sizes as shown in the part number table.

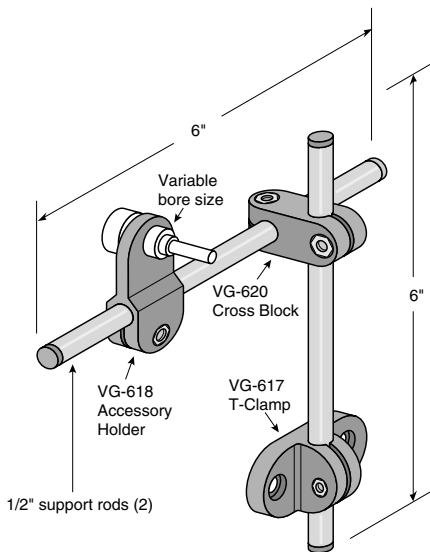

Part Number	Support \O Rod (in.)	Accessory Holder \O Bore (in.)
VG-615A-12-14	1/2	1/4
VG-615A-12-38	1/2	3/8
VG-615A-12-12	1/2	1/2
VG-615A-12-58	1/2	5/8
VG-615A-12-34	1/2	3/4

Brackets & Positioning



Accessory Mount Components for 10mm Rod

614-10M

Reflector Mount

Used to hold reflectors using a cap screw and nut or press-in clip onto Ø10mm support rods.



Accepts 10 mm round rod or 8 mm square rod!

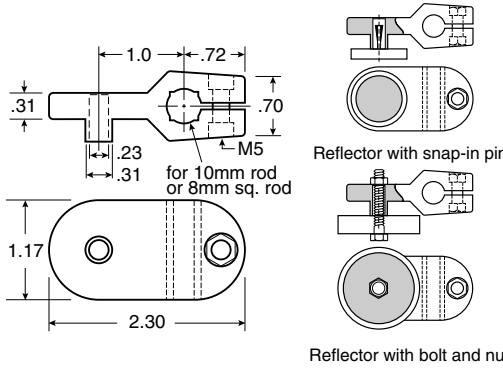

Material: Reinforced polyamide body with stainless steel fasteners.

Part Number	Ø Rod (mm)
VG-614-10M	10mm/8mm sq.

Note: Reflectors not included.

618-10M

Accessory Holder

Used to hold many types of accessories onto Ø10mm support rods. A variety of bore sizes are available.



Accepts 10 mm round rod or 8 mm square rod!

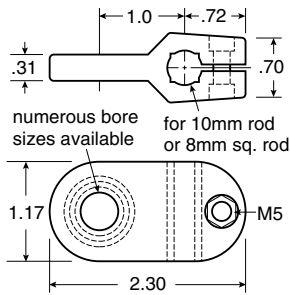

Part Number	Support Ø Rod (mm)	Accessory Ø Bore (mm)
VG-618-10M-6	10mm/8mm sq.	6
VG-618-10M-10	10mm/8mm sq.	10
VG-618-10M-12	10mm/8mm sq.	12
VG-618-10M-19	10mm/8mm sq.	19

617-10M

T-Clamp

Mounts to side of equipment to provide support for light duty rod type guide rail systems. Part of the VG-615 series accessory holder assembly.

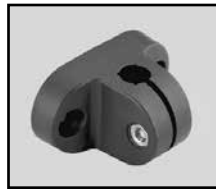

Accepts 10 mm round rod or 8 mm square rod!

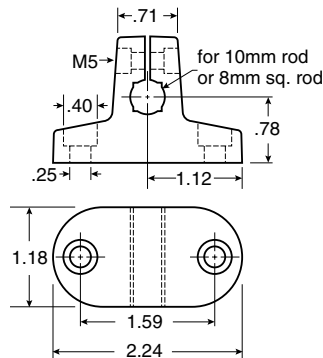

Part Number	Support Ø Rod (mm)
VG-617-10M	10mm/8mm sq.

619-10M

Rod to Rod Cross Block

Connects two 10mm round rods or 8mm square rods at 90°. Part of the VG-615R-10M or VG-615A-10M accessory holder assembly.



Accepts 10 mm round rod or 8 mm square rod!

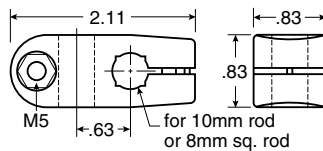

Part Number	Support Ø Rod (mm)
VG-619-10M	10mm/8mm sq.

616

Ø 10mm Support Rod

This 10mm OD stainless steel tube can be used with accessory cross blocks, holders and clamps. The ends are capped with a black polyethylene plug.

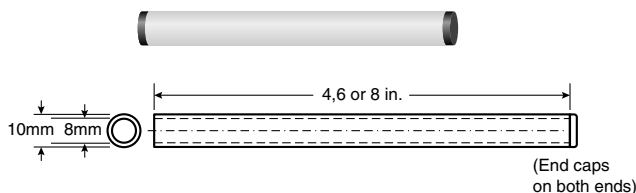

Material: Stainless steel tube. Black polyethylene end caps.

Part Number	Length (in.)
VG-616-06-10M	6
VG-616-08-10M	8

Brackets & Positioning



VG-615R-10M consists of the following parts:

615R-10M

Reflector Mounting Assembly

The assembly for holding reflectors is available with Ø10mm support rods and corresponding attachments.

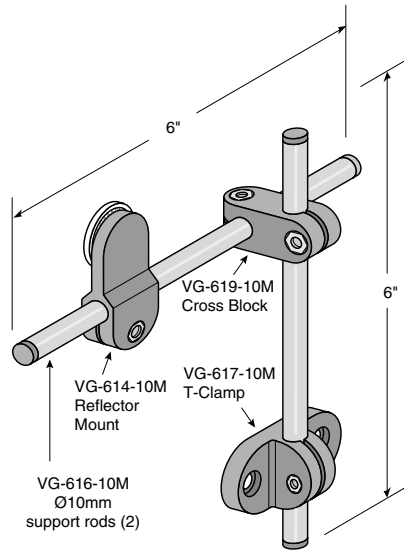

Material: Corrosion resistant thermoplastic parts with stainless steel fasteners. Stainless steel tubes with plastic insert caps.

Part Number	Ø Support Rod
VG-615R-10M	10mm

VG-615A-10M- assemblies consist of the following parts:

615A-10M

Sensor Mounting Assembly

The assembly for holding sensors is available with Ø10mm inch support rods and corresponding attachments. The accessory holder attachment is available in a variety of bore sizes as shown in the part number table.

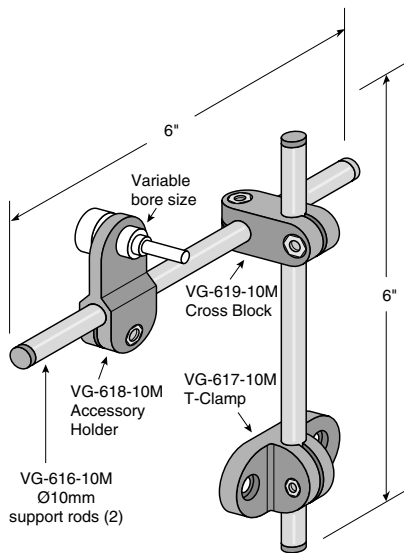

Part Number	Support Ø Rod (mm)	Accessory Ø Bore (mm)
VG-615A-10M-6	10mm	6
VG-615A-10M-10	10mm	10
VG-615A-10M-19	10mm	19

Brackets & Positioning

SC

Locking Shaft Collars

For holding idler wheels or various other sprockets in place on a shaft. Also can be used with Valu Guide adjusting rods to set guide rail positions for two container sizes.

- Available with or without keyways.
- Convenient hinge keeps parts together for easy installation.
- Fastening hardware included.

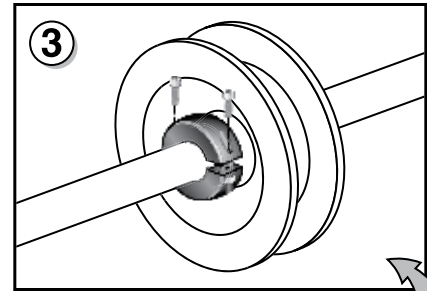
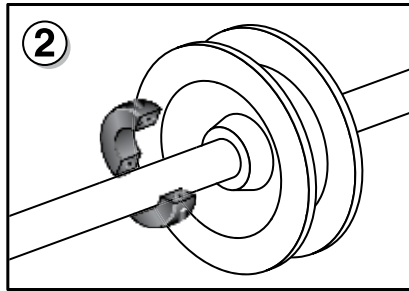
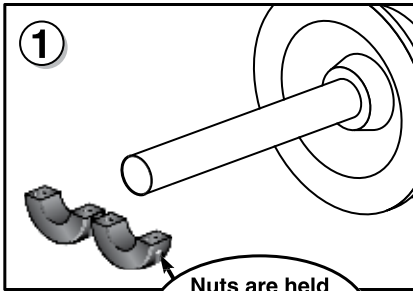
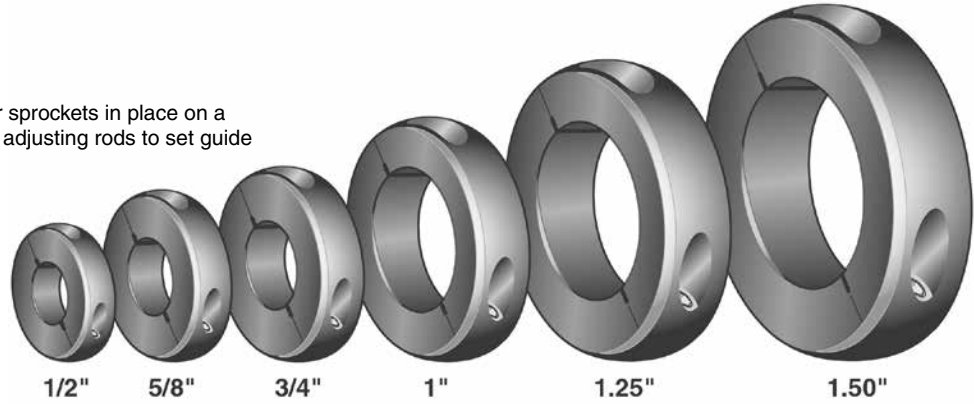

Shaft Collars can be used with idler wheels. See page 104.

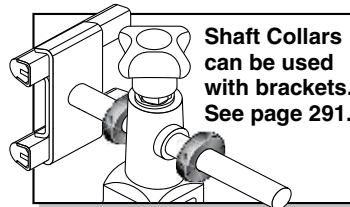
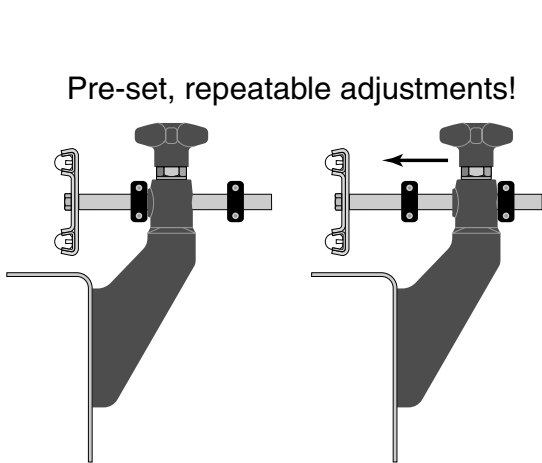

Easy to install on existing lines!

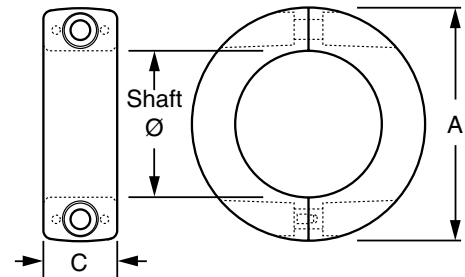

Material: Polyamide ring with stainless steel and nickel plated brass hardware.

Part Number	with keyway	A	Shaft Ø	C	keyway
VG-SC-12	-	1.10	1/2"	.46	-
VG-SC-58	-	1.22	5/8"	.46	-
VG-SC-34	-	1.50	3/4"	.55	-
VG-SC-100	VG-SCK-100	1.75	1"	.55	1/4"
VG-SC-125	VG-SCK-125	2.00	1-1/4"	.63	1/4"
VG-SC-150	VG-SCK-150	2.50	1-1/2"	.70	3/8"

SCK

Locking Shaft Collars with Keyway

For holding sprockets or idler wheels on keyed shafts.

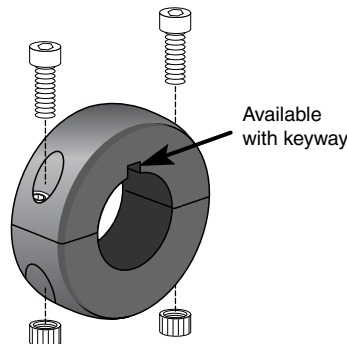



Levelers Page 342
 Tube Ends Adjustable Levelers
 Vibration Pads Threaded Rod

MACHINE & EQUIPMENT COMPONENTS

Section 7



Sub-Structures... Page 369
 Post Caps Connecting Joint
 Leg Tie Tripod Bases
 Bipod Bases Sanitary Leg

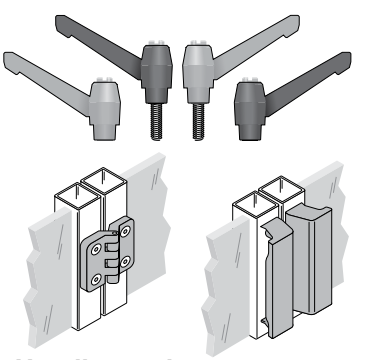

Handles and Hinges..... Page 376
 Ratchet Handles Standard Handles
 Heavy Duty Handles Safety Handles
 Standard Hinges Heavy Duty Hinges

Round Tube Ends

Conveyor and machinery support for use with System Plast adjustable levels.

Save Time & Labor!

No welding, drilling or tapping!

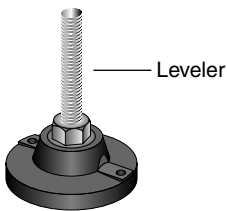
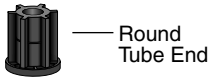
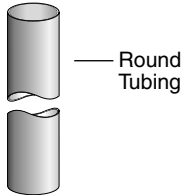
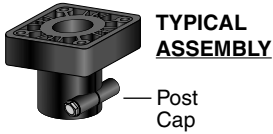

Material: Reinforced polyamide with brass threaded insert.

Part Number	A	B	C	L	S	Tube Size	Static Load	
VG-550-B38	3/8-16	1.50"	1.37"	1.71"	1.38"	<p>1-1/2" Tube</p>	1000 lbs.	
VG-550-B12	1/2-13							
VG-550-B58	5/8-11							
VG-550-B34	3/4-10							
VG-550-BM16 <i>(14764 equivalent)</i>	M16	1.78"	1.78"	1.71"	1.38"	<p>1-1/2" Sch. 5 Pipe</p>		
VG-550-BM20	M20							
VG-558-B38	3/8-16							
VG-558-B12	1/2-13							
VG-558-B58 <i>(34221 equivalent)</i>	5/8-11	1.97"	1.78"	1.95"	1.54"	<p>1-1/2" Sch. 10 Pipe</p>		1760 lbs.
VG-558-B34 <i>(34768 equivalent)</i>	3/4-10							
VG-558-BM16 <i>(14767 equivalent)</i>	M16							
VG-558-BM20 <i>(14751 equivalent)</i>	M20							
VG-551-B38	3/8-16	1.91"	1.91"	1.95"	1.54"	<p>2" Tube</p>	1000 lbs.	
VG-551-B12	1/2-13							
VG-551-B58	5/8-11							
VG-551-B34	3/4-10							
VG-551-BM16	M16	1.91"	1.91"	1.95"	1.54"	<p>2" Tube</p>	1760 lbs.	
VG-554-B38	3/8-16							
VG-554-B12	1/2-13							
VG-554-B58	5/8-11							
VG-554-B34	3/4-10	1.65"	1.57"	1.65"	1.34"	<p>1-1/4" Sch. 5 Pipe</p>	1000 lbs.	
VG-554-BM16 <i>(14755 equivalent)</i>	M16							
VG-554-BM20	M20							
34219	3/8-16						2.37"	2.20"
34763	1/2-13							
34764	5/8-11							
34211	5/8-11	2.37"	2.20"	1.97"	1.50"	<p>2" Sch. 10 Pipe</p>	1700 lbs.	

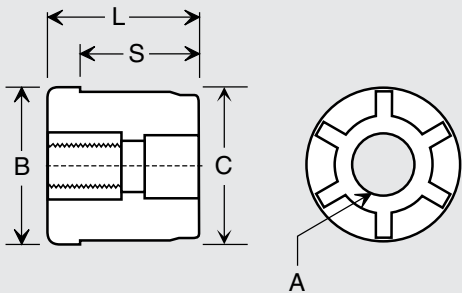

Machine & Equip. Components

Threaded Tube Ends



Square Tube Ends

Conveyor and machinery support for use with System Plast adjustable levelers.

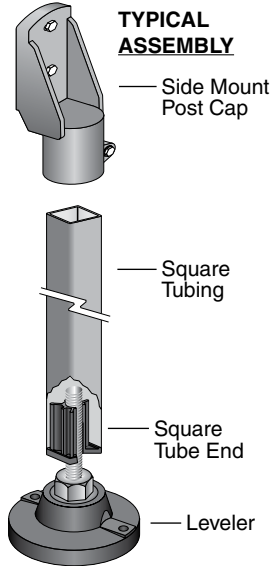

Material: Reinforced polyamide with brass threaded insert.

Part Number	A	B	C	L	S	Tube Size	Static Load
VG-552-B38	3/8-16	1.50"	1.37"	1.71"	1.38"		1000 lbs.
VG-552-B12	1/2-13						
VG-552-B58	5/8-11						
VG-552-B34	3/4-10						
VG-552-BM16 (14757 equivalent)	M16	1.50"	1.37"	1.71"	1.38"		1000 lbs.
VG-553-B38	3/8-16						
VG-553-B12	1/2-13						
VG-553-B58	5/8-11						
VG-553-B34	3/4-10	1.97"	1.87"	1.96"	1.55"		1760 lbs.
VG-555-B38	3/8-16						
VG-555-B12	1/2-13						
VG-555-B58	5/8-11						
VG-555-B34	3/4-10	1.97"	1.78"	1.96"	1.55"		1000 lbs.
VG-555-BM16 (14607 equivalent)	M16						
VG-556-B38	3/8-16						
VG-556-B12	1/2-13						
VG-556-B58	5/8-11	1.00"	0.89"	1.18"	1.00"		1100 lbs.
VG-556-B34	3/4-10						
VG-556-BM16 (14797 equivalent)	M16						
VG-556-BM20	M20						
34200	3/8-16	1.00"	0.89"	1.18"	1.00"		1100 lbs.
34201	1/2-13						
34018	3/8-16	1.18"	1.08"	1.30"	1.06"		1200 lbs.
34040	5/8-11	2.37"	2.22"	2.17"	1.77"		1300 lbs.
VG-561-B58	5/8-11	2.37"	2.22"	2.17"	1.77"		1760 lbs.
VG-561-B34	3/4-10						
VG-561-BM16	M16						
VG-561-BM20	M20						

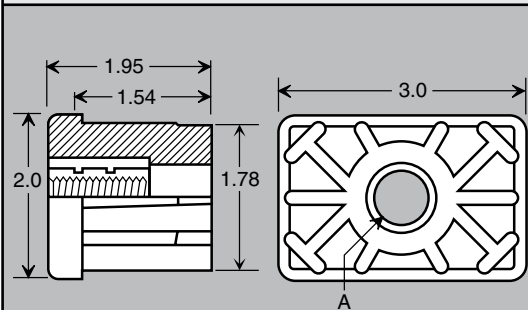
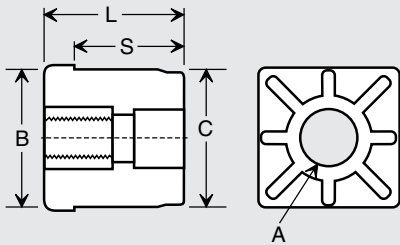

Machine & Equip. Components



560

Tube Cap

This smooth plastic cap serves as a practical and aesthetic plug/cover for the ends of square tubing.

Material: ABS plastic.

Part Number	Tube (sq) x wall
VG-560-1.5-16	1-1/2" x .065"
VG-560-1.5-11	1-1/2" x .120"
VG-560-2.0-11	2" x .120"

NOTE: Tube Ends provide a friction fit and should be installed with a rubber hammer.



SaniStar

Stainless Steel Leveler

Conveyor and machinery support with built-in vibration pad, polished surface, and sanitary design.

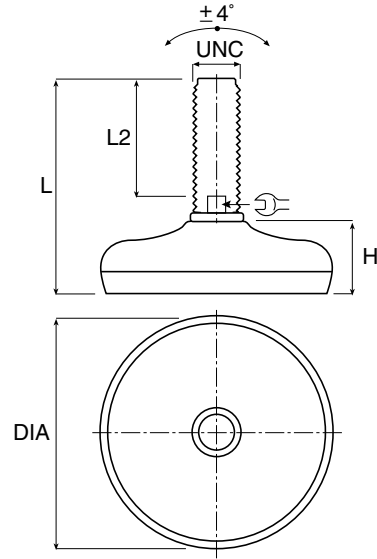

2 Inch Diameter Base

Maximum Recommended Static Load: 680 lbs.

Base Material: Stainless steel and rubber (70 shore).
Stem material: Stainless steel.

Part Number	Stem UNC Thread	H	L2	L
177003U	1/2-13	.83	2.75	3.75
177004U	1/2-13	.83	3.50	4.55
177005U	1/2-13	.83	4.65	5.30
177006U	1/2-13	.83	5.0	6.10
177010U	5/8-11	.83	2.75	3.95
177011U	5/8-11	.83	4.25	5.50

3 Inch Diameter Base

Maximum Recommended Static Load: 1800 lbs.

Base Material: Stainless steel and rubber (70 shore).
Stem material: Stainless steel.

Part Number	Stem UNC Thread	H	L2	L
177053U	1/2-13	.91	2.75	3.95
177054U	1/2-13	.91	3.50	4.70
177055U	1/2-13	.91	4.65	5.50
177056U	1/2-13	.91	5.0	6.30
177060U	5/8-11	.91	2.75	3.95
177061U	5/8-11	.91	4.25	5.50
177062U	5/8-11	.91	6.15	7.50

4 Inch Diameter Base

Maximum Recommended Static Load: 4500 lbs.

Base Material: Stainless steel and rubber (70 shore).
Stem material: Stainless steel.

Part Number	Stem UNC Thread	H	L2	L
177104U	5/8-11	1.18	4.25	5.70
177105U	5/8-11	1.18	6.15	7.70
177108U	3/4-10	1.18	4.45	6.10
177109U	3/4-10	1.18	6.15	7.85
177110U	3/4-10	1.18	7.25	9.05

5 Inch Diameter Base

Maximum Recommended Static Load: 6800 lbs.

Base Material: Stainless steel and rubber (70 shore).
Stem material: Stainless steel.

Part Number	Stem UNC Thread	H	L2	L
177158U	3/4-10	1.26	4.45	6.10
177159U	3/4-10	1.26	6.15	7.85
177160U	3/4-10	1.26	7.25	9.05

General tolerance on total height (L dim) is $\pm .08$ inch.

Machine & Equip. Components



SaniStar

Stainless Steel Leveler with Mounting Hole

Conveyor and machinery support with built-in vibration pad, polished surface, and sanitary design.

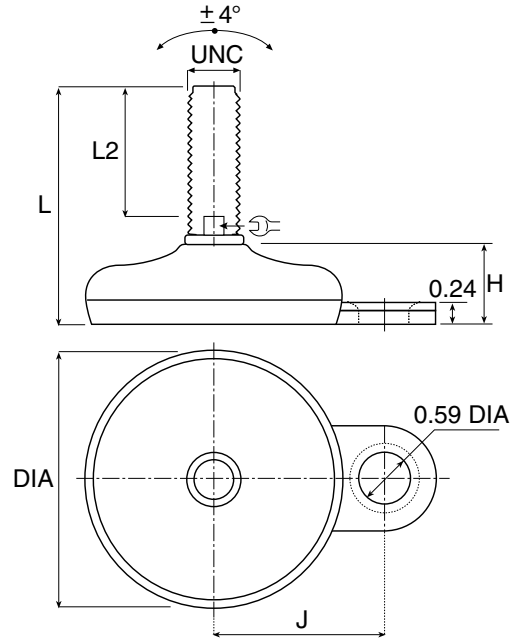

3 Inch Diameter Base with Mounting Hole

Maximum Recommended Static Load: 1800 lbs.

Base Material: Stainless steel and rubber (70 shore).
Stem material: Stainless steel.

Part Number	Stem		H	J	L2	L
	UNC Thread					
177203U	1/2-13	.91	2.07	2.75	3.95	
177204U	1/2-13	.91	2.07	4.65	5.30	
177205U	1/2-13	.91	2.07	3.50	4.80	
177206U	1/2-13	.91	2.07	5.0	6.30	
177210U	5/8-11	.91	2.07	2.75	3.95	
177211U	5/8-11	.91	2.07	4.25	5.50	

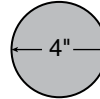

4 Inch Diameter Base with Mounting Hole

Maximum Recommended Static Load: 4500 lbs.

Base Material: Stainless steel and rubber (70 shore).
Stem material: Stainless steel.

Part Number	Stem		H	J	L2	L
	UNC Thread					
177254U	5/8-11	1.18	2.56	4.25	5.70	
177255U	5/8-11	1.18	2.56	6.15	7.70	
177258U	3/4-10	1.18	2.56	4.45	6.10	
177259U	3/4-10	1.18	2.56	6.15	7.85	
177260U	3/4-10	1.18	2.56	7.25	9.05	

Machine & Equip. Components

General tolerance on total height (L dim) is ± .08 inch.



SaniStar

Stainless Steel Leveler with Thread Cover

Conveyor and machinery support with built-in vibration pad, polished surface, and sanitary design.

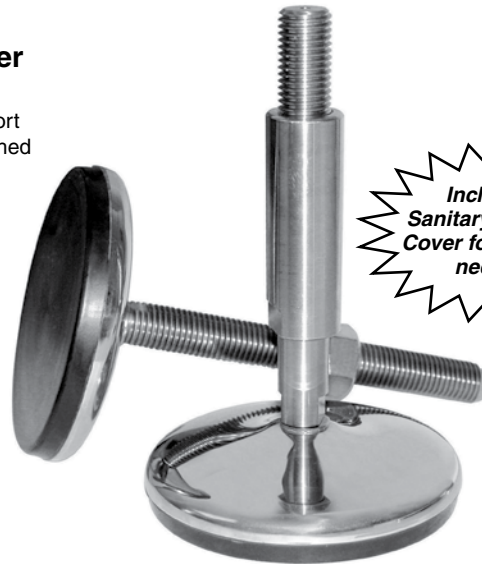

Includes Sanitary Thread Cover for HACCP needs!

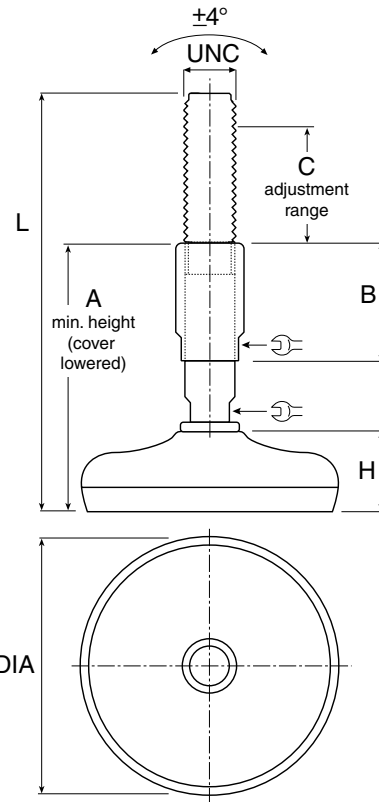

3 Inch Diameter Base with Thread Cover

Maximum Recommended Static Load: 1800 lbs.

Base Material: Stainless steel and rubber (70 shore).
Stem material: Stainless steel.

Part Number	Stem		H	B	A	C	L
	UNC Thread						
177300U	5/8-11	.91	2.17	3.55	1.45	7.30	
177301U	5/8-11	.91	3.35	4.75	2.65	9.25	
177302U	3/4-10	.91	2.17	3.55	1.45	7.30	
177303U	3/4-10	.91	3.35	4.75	2.65	9.25	

4 Inch Diameter Base with Thread Cover

Maximum Recommended Static Load: 4500 lbs.

Base Material: Stainless steel and rubber (70 shore).
Stem material: Stainless steel.

Part Number	Stem		H	B	A	C	L
	UNC Thread						
177310U	5/8-11	1.18	2.17	3.75	1.45	7.50	
177311U	5/8-11	1.18	3.35	4.95	2.65	9.45	
177312U	3/4-10	1.18	2.17	3.75	1.45	7.50	
177313U	3/4-10	1.18	3.35	4.95	2.65	9.45	

5 Inch Diameter Base with Thread Cover

Maximum Recommended Static Load: 6800 lbs.

Base Material: Stainless steel and rubber (70 shore).
Stem material: Stainless steel.

Part Number	Stem		H	B	A	C	L
	UNC Thread						
177321U	5/8-11	1.26	3.35	5.15	2.65	9.65	
177322U	3/4-10	1.26	2.17	3.95	1.45	7.70	
177323U	3/4-10	1.26	3.35	5.15	2.65	9.65	

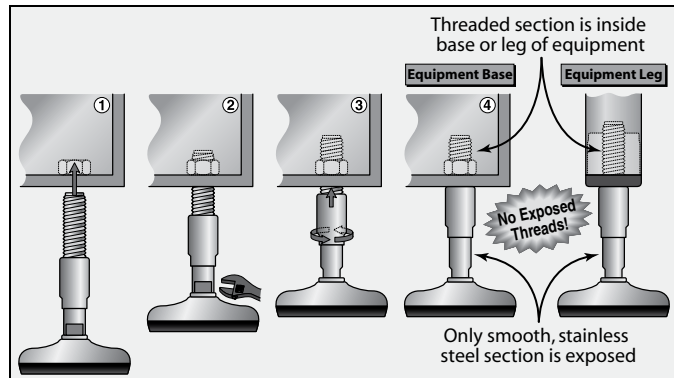

General tolerance on total height (L dim) is $\pm .08$ inch.



SaniStar

Stainless Steel Leveler with Thread Cover

Conveyor and machinery support with built-in vibration pad, polished surface, and sanitary design.



Includes Sanitary Thread Cover for HACCP needs!

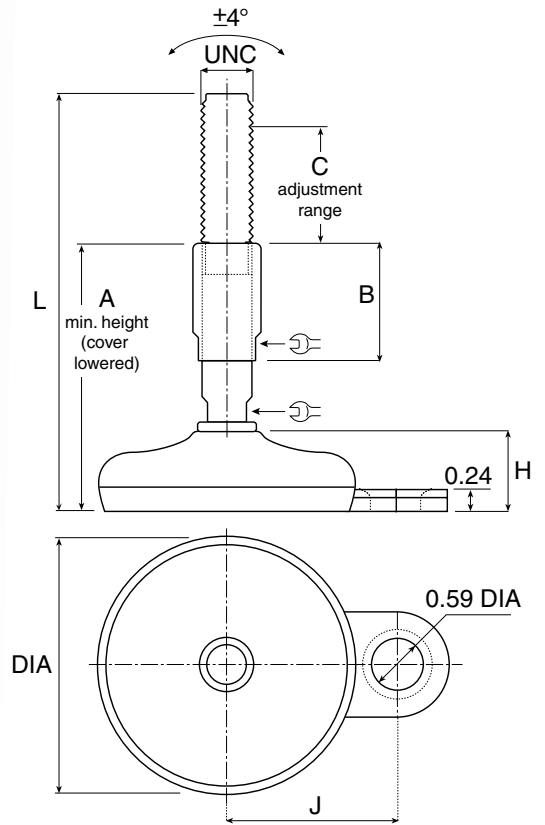

3 Inch Diameter Base with Mounting Hole and Thread Cover

Maximum Recommended Static Load: 1800 lbs.

Base Material: Stainless steel and rubber (70 shore).
Stem material: Stainless steel.

Part Number	Stem UNC Thread	H	B	J	A	C	L
177350U	5/8-11	.91	2.17	2.1	3.55	1.45	7.30
177351U	5/8-11	.91	3.35	2.1	4.75	2.65	9.25
177352U	3/4-10	.91	2.17	2.1	3.55	1.45	7.30
177353U	3/4-10	.91	3.35	2.1	4.75	2.65	9.25

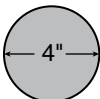

4 Inch Diameter Base with Mounting Hole and Thread Cover

Maximum Recommended Static Load: 4500 lbs.

Base Material: Stainless steel and rubber (70 shore).
Stem material: Stainless steel.

Part Number	Stem UNC Thread	H	B	J	A	C	L
177360U	5/8-11	1.18	2.17	2.56	3.75	1.45	7.50
177361U	5/8-11	1.18	3.35	2.56	4.95	2.65	9.45
177362U	3/4-10	1.18	2.17	2.56	3.75	1.45	7.50
177363U	3/4-10	1.18	3.35	2.56	4.95	2.65	9.45

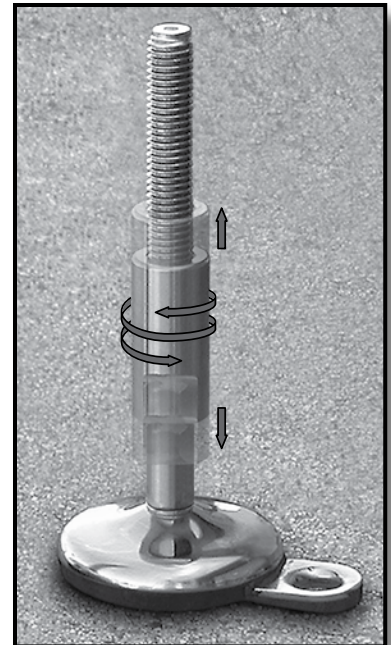

Machine & Equip. Components

General tolerance on total height (L dim) is ± .08 inch.



Leveling Pads

Stainless Steel Leveler with Leveling Pad

Conveyor and machinery support with anti-slip pad, polished surface, and sanitary design.

Maximum Recommended Static Load: 11000 lbs.

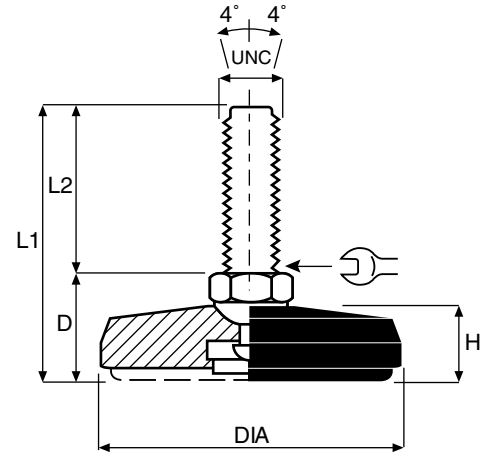

3.15 Inch Diameter Base with Leveling Pad

Maximum Recommended Static Load: 11000 lbs.

Base and Stem Material: Stainless steel.
Pad Material: Anti-slip rubber (70 shore).

Part Number	Stem		DIA	H	D	L1	L2
	UNC Thread						
37692	5/8-11		3.15	.95	1.54	6.46	4.92
38309	3/4-10		3.15	.95	1.54	6.46	4.92
38310	3/4-10		3.15	.95	1.54	8.82	7.28

3.94 Inch Diameter Base with Leveling Pad

Maximum Recommended Static Load: 11000 lbs.

Base and Stem Material: Stainless steel.
Pad Material: Anti-slip rubber (70 shore).

Part Number	Stem		DIA	H	D	L1	L2
	UNC Thread						
38322	3/4-10		3.94	.95	1.54	8.82	7.28
38324	1-8		3.94	.95	1.54	8.82	7.28

4.72 Inch Diameter Base with Leveling Pad

Maximum Recommended Static Load: 11000 lbs.

Base and Stem Material: Stainless steel.
Pad Material: Anti-slip rubber (70 shore).

Part Number	Stem		DIA	H	D	L1	L2
	UNC Thread						
38333	3/4-10		4.72	1.10	1.69	6.61	4.92
38334	3/4-10		4.72	1.10	1.69	8.97	7.28
38336	1-8		4.72	1.10	1.69	8.97	7.28

Machine & Equip. Components

General tolerance on total height (L dim) is ± .08 inch.



Leveling Pads

Stainless Steel Leveler with Leveling Pad

Conveyor and machinery support with anti-slip pad, polished surface, and sanitary design.

Maximum Recommended Static Load: 11000 lbs.

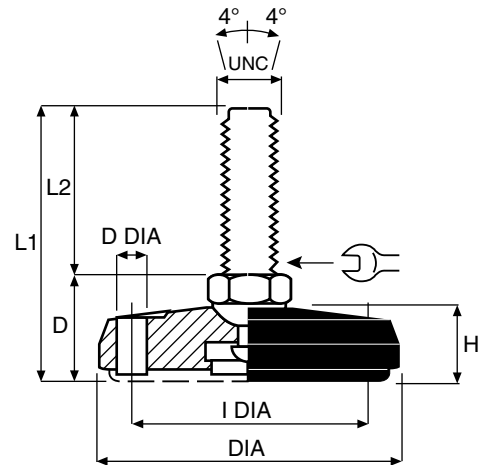

3.15 Inch Diameter Base with Leveling Pad

Maximum Recommended Static Load: 11000 lbs.

Base and Stem Material: Stainless steel. **Pad Material:** Anti-slip rubber (70 shore).

Part Number	Stem		DIA	I DIA	D DIA	H	D	L1	L2
	UNC Thread								
37710	5/8-11		3.15	2.13	.35	.87	1.46	6.38	4.92
37712	3/4-10		3.15	2.13	.35	.87	1.46	6.38	4.92
37713	3/4-10		3.15	2.13	.35	.87	1.46	8.74	7.28

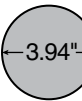

3.94 Inch Diameter Base with Leveling Pad

Maximum Recommended Static Load: 11000 lbs.

Base and Stem Material: Stainless steel. **Pad Material:** Anti-slip rubber (70 shore).

Part Number	Stem		DIA	I DIA	D DIA	H	D	L1	L2
	UNC Thread								
37737	3/4-10		3.94	2.89	.47	.95	1.54	6.46	4.92
37738	3/4-10		3.94	2.89	.47	.95	1.54	8.82	7.28
37740	1-8		3.94	2.89	.47	.95	1.54	8.82	7.28

Machine & Equip. Components

General tolerance on total height (L dim) is ± .08 inch.

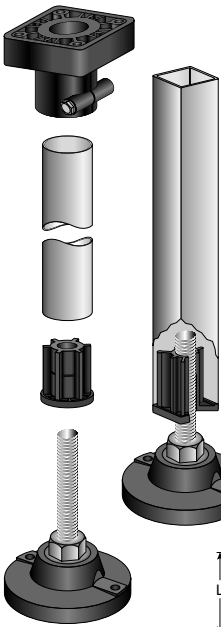

VALU GUIDE™

Leveler Advantages:

✓ Loc-A-Lign™

Designed for conditions where the foot is exposed to severe lateral impact or upward pressure such as frequent relocation or transporting of equipment. A fastener attached to the stem through the base is used to help prevent separation of the base from the stem.



✓ Stem Materials

All leveler stems are available in either 300 series stainless steel for total protection against severe environments or zinc plated steel for economical corrosion resistance.

✓ Base Materials

Corrosion resistant, reinforced polyamide offers superior strength and can operate continuously in temperatures up to 190° F. The VG-525 base material is cast Nylathane. The design allows the levelers to carry loads up to 7,200 pounds. Metal bases are either 300 series stainless steel or zinc plated steel and have load capacities up to 22,000 pounds.

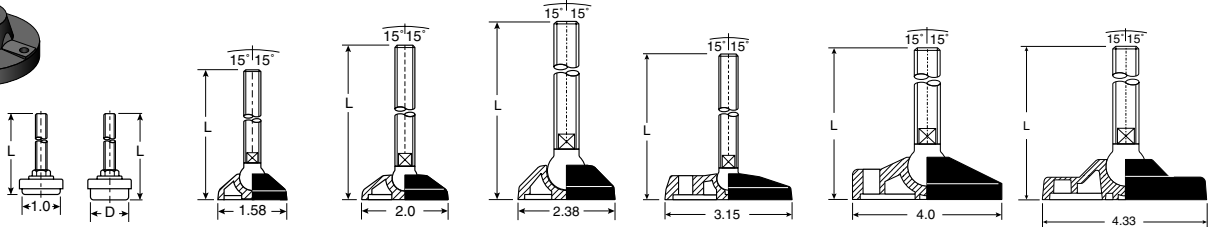

Part Number	VG-580		VG-533	VG-537	VG-501	VG-505	VG-511	VG-518
Static Load (lbs) 2:1 safety factor included	100	100 300	700	700	2000	2000	2600	4000
Available Thread Sizes	5/16-18	5/16-18 (D=1.0) 3/8-16 1/2-13 (D=1.5)	3/8-16 M10 1/2-13 M12 5/8-11 M16	3/8-16 M10 1/2-13 M12 5/8-11 M16	1/2-13 M12 5/8-11 M16 3/4-10 M20	3/8-16 M10 1/2-13 M12 5/8-11 M16	1/2-13 M12 5/8-11 M16 3/4-10 M20	1/2-13 M12 5/8-11 M16 3/4-10 M20
Overall Length (L) ±1/8" Note: Not all thread sizes are available in all lengths	2.13"	2.31" 3.06" 3.98"	3.70"	3.90" 6.10"	4.54" 6.22" 7.71" 10.71"	3.74" 5.93"	4.52" 6.20" 7.69" 10.69"	4.68" 6.36" 7.85" 10.85"
Articulation	N/A	±15°	±15°	±15° Loc-A-Lign ±5°	±15°	±15° Loc-A-Lign ±5°	±15° Loc-A-Lign ±5°	±15° Loc-A-Lign ±5°
Loc-A-Lign™ Available	N/A	N/A	N/A	Yes	N/A	Yes	N/A	
Vibration Pad	Standard on VG-580	VG-534	VG-538	VG-504	VG-506	VG-512	VG-516	
Lag Holes Available	N/A	N/A	N/A	N/A	Double	Single, Double	N/A	
Page Number	368	352	352	353	354	355-358	360	
Solid Base Available	N/A	N/A	N/A	VG-501D page 363	VG-505D page 364	N/A	N/A	
Socket Style	N/A	N/A	N/A	N/A	N/A	VG-511B page 365	N/A	

Machine & Equip. Components

✓ Lag Holes

Selected bases are available with single or double lag holes. Single lag holes are especially convenient when access to the base for anchoring purposes is limited.



✓ Threaded Tube Ends

Easily installed on either round or square tubing, tube ends make it easy to add levelers to most conveyor or machinery supports. Simply place the friction fit tube end into the tubing and knock together with a rubber hammer.



✓ Socket Style Bases

Sockets available in stainless or plated steel. For those applications where an existing stud is present or a custom spindle is required, we can provide a socket style base. Threaded rod for all socket sizes are available in carbon, zinc plated or stainless steel.



Leveler Ordering Information:

VG - 511 - 02 - S34 - L7

model # spindle material/diameter base style approx. OAL

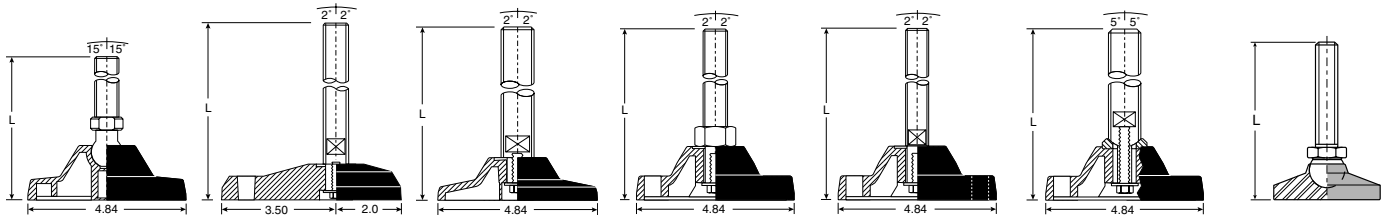

VG-513	VG-525	VG-517-K	VG-520	VG-520-K	VG-520-T	VG-590 Series
4400	7200	7000	7000	7000	7000	5000 - 22000
3/4-10 M20 1-8 M24	3/4-10 M20 1-8 M24 1 1/8-7 1 1/4-7	3/4-10 M20 1-8 M24 1 1/8-7 1 1/4-7	3/4-10 M20 1-8 M24	3/4-10 M20 1-8 M24 1 1/8-7 1 1/4-7	1-8 M24 1 1/8-7 1 1/4-7	1/2-13 M12 5/8-11 M16 3/4-10 M20 1-8
5.53" 7.03" 8.15" 8.52" 11.52"	7.25"	7.50"	5.97" 7.48" 10.07"	7.50"	7.45" 9.95" 11.95"	1.5" - 9.88"
±15°	±3°	±2°	±2°	±2°	±5°	±15°
N/A	N/A	N/A	N/A	N/A	Yes	N/A
VG-514 VG-514N	N/A	VG-514 VG-514N	VG-514 VG-514N	VG-514 VG-514N	VG-514 VG-514N	N/A
N/A	Single	N/A	Double	Double	Double	N/A
359	364	361	361	362	362	367-368
N/A	VG-525 Page 364	N/A	N/A	N/A	N/A	Standard
VG-513B page 365	N/A	N/A	N/A	N/A	N/A	590B series page 368

Machine & Equip. Components



533

Articulating Leveler

Support for light duty machines.

Maximum Recommended Static Load: 700 lbs.

Includes 2:1 safety factor.

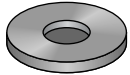

VG-534 Vibration Pad

Neoprene rubber.

Fits any VG-533 series leveler.

Sold separately. See page 363.

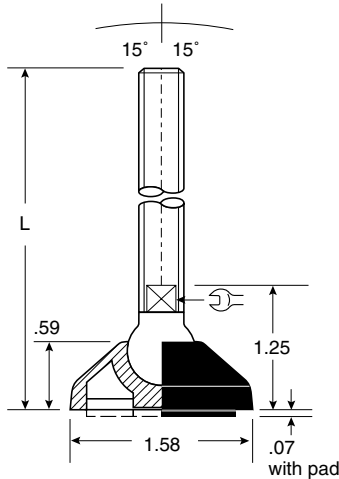

Base Material: Reinforced polyamide

Part Number	Stem Thread	Stem Material		"L" Dim
		Zinc	Stainless	
VG-533-01-P38-L3	3/8-16	P		3.70"
VG-533-01-S38-L3	3/8-16		S	3.70"
VG-533-01-P12-L3	1/2-13	P		3.70"
VG-533-01-S12-L3	1/2-13		S	3.70"
VG-533-01-P58-L3	5/8-11	P		3.70"
VG-533-01-S58-L3	5/8-11		S	3.70"
VG-533-01-PM10-L3	M10	P		3.70"
VG-533-01-SM12-L3	M12		S	3.70"
VG-533-01-PM16-L3	M16	P		3.70"
VG-533-01-SM16-L3	M16		S	3.70"

537

Articulating Leveler

Support for light duty machines.

Maximum Recommended Static Load: 700 lbs.

Includes 2:1 safety factor.

Machine & Equip. Components

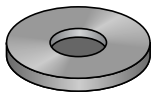

VG-538 Vibration Pad

Neoprene rubber.

Fits any VG-537 series leveler.

Sold separately. See page 363.

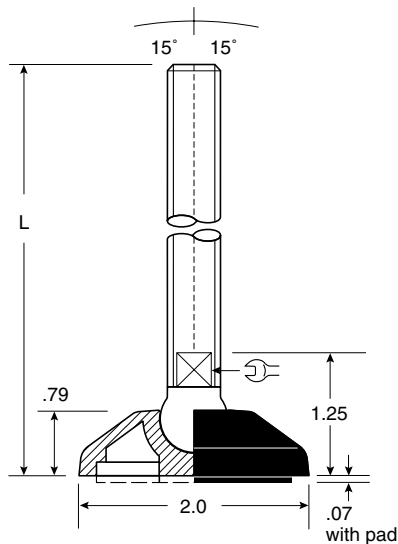

Base Material: Reinforced polyamide

Part Number	Stem Thread	Stem Material		"L" Dim
		Zinc	Stainless	
VG-537-01-P38-L3	3/8-16	P		3.90"
VG-537-01-S38-L3	3/8-16		S	3.90"
VG-537-01-P12-L3	1/2-13	P		3.90"
VG-537-01-S12-L3	1/2-13		S	3.90"
VG-537-01-P12-L5	1/2-13	P		6.10"
VG-537-01-S12-L5	1/2-13		S	6.10"
VG-537-01-P58-L3	5/8-11	P		3.90"
VG-537-01-S58-L3	5/8-11		S	3.90"
VG-537-01-P58-L5	5/8-11	P		6.10"
VG-537-01-S58-L5	5/8-11		S	6.10"
VG-537-01-PM10-L3	M10	P		3.90"
VG-537-01-PM12-L3	M12	P		3.90"
VG-537-01-SM12-L3	M12		S	3.90"
VG-537-01-PM12-L5	M12	P		6.10"
VG-537-01-SM12-L5	M12		S	6.10"
VG-537-01-PM16-L3	M16	P		3.90"
VG-537-01-SM16-L3	M16		S	3.90"
VG-537-01-PM16-L5	M16	P		6.10"



501

Articulating Leveler

Conveyor and machinery support.

Maximum Recommended Static Load: 2000 lbs.
Includes 2:1 safety factor.

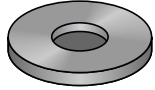

VG-504 Vibration Pad

Neoprene rubber.
Fits any VG-501 series leveler.
Sold separately. See page 363.

NOTE:

The VG-501 style levelers are available with the underside cavity entirely and permanently filled with urethane, adding 1/8" to the leveler height. Please specify by replacing base style -01 with a -U1 in the part number:

VG-501-01-P12-L3 becomes VG-501-U1-P12-L3

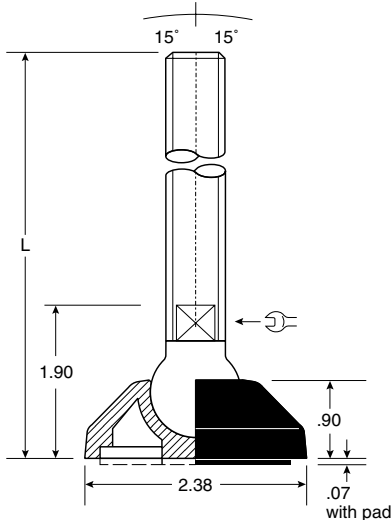

Base Material: Reinforced polyamide				
Part Number	Stem Thread	Stem Material		"L" Dim
		Zinc	Stainless	
VG-501-01-P12-L3	1/2-13	P		4.54"
VG-501-01-S12-L3	1/2-13		S	4.54"
VG-501-01-P12-L5	1/2-13	P		6.22"
VG-501-01-S12-L5	1/2-13		S	6.22"
VG-501-01-P58-L3	5/8-11	P		4.54"
VG-501-01-S58-L3	5/8-11		S	4.54"
VG-501-01-P58-L5	5/8-11	P		6.22"
VG-501-01-S58-L5	5/8-11		S	6.22"
VG-501-01-P58-L8	5/8-11	P		7.71"
VG-501-01-S58-L8	5/8-11		S	7.71"
VG-501-01-P34-L5	3/4-10	P		6.22"
VG-501-01-S34-L5	3/4-10		S	6.22"
VG-501-01-P34-L8	3/4-10	P		7.71"
VG-501-01-S34-L8	3/4-10		S	7.71"
VG-501-01-P34-L10	3/4-10	P		10.71"
VG-501-01-S34-L10	3/4-10		S	10.71"
VG-501-01-PM16-L3	M16	P		4.51"
VG-501-01-SM16-L3	M16		S	4.51"
VG-501-01-PM16-L5	M16	P		6.22"
VG-501-01-SM16-L5	M16		S	6.22"
VG-501-01-PM16-L8	M16	P		7.71"
VG-501-01-SM16-L8	M16		S	7.71"
VG-501-01-SM20-L8	M20		S	7.71"

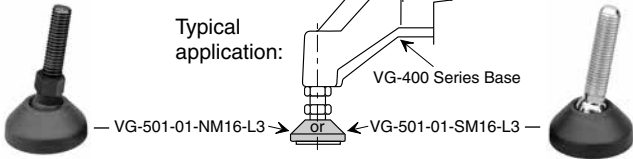

501-T

Loc-A-Lign™ Series Articulating Leveler

Conveyor and machinery support where resistance to stem pull-out is required.

Maximum Recommended Static Load: 2000 lbs.
Includes 2:1 safety factor.



VG-504 Vibration Pad

Neoprene rubber.
Fits any VG-501 series leveler.
Sold separately. See page 363.

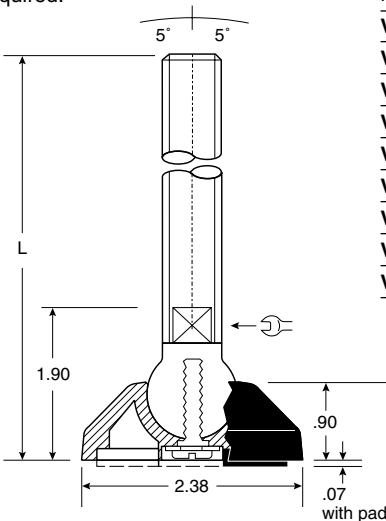

Base Material: Reinforced polyamide				
Loc-A-Lign Fastener: Stainless steel or zinc plated				
Part Number	Stem Thread	Stem Material		"L" Dim
		Zinc	Stainless	
VG-501-01-P12-L5T	1/2-13	P		6.22"
VG-501-01-S12-L5T	1/2-13		S	6.22"
VG-501-01-P58-L5T	5/8-11	P		6.22"
VG-501-01-S58-L5T	5/8-11		S	6.22"
VG-501-01-P58-L8T	5/8-11	P		7.71"
VG-501-01-S58-L8T	5/8-11		S	7.71"
VG-501-01-P34-L8T	3/4-10	P		7.71"
VG-501-01-S34-L8T	3/4-10		S	7.71"
VG-501-01-S34-L10T	3/4-10		S	10.71"

Machine & Equip. Components

Adjustable Levelers — Medium Duty



VG-505-01-

VG-505-02-

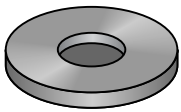

VG-506 Vibration Pad

Neoprene rubber.
Fits any VG-505 series leveler.
Sold separately. See page 363.

505

Articulating Leveler

Conveyor and machinery support.

Maximum Recommended

Static Load: 2000 lbs.

Includes 2:1 safety factor.

Base Material: Reinforced polyamide

Part Number		Stem Thread	Stem Material		"L" Dim
Without Lag Holes	With Two Lag Holes		Zinc	Stainless	
VG-505-01-P38-L3	VG-505-02-P38-L3	3/8-16	P		3.74"
VG-505-01-S38-L3	VG-505-02-S38-L3	3/8-16		S	3.74"
VG-505-01-P12-L3	VG-505-02-P12-L3	1/2-13	P		3.74"
VG-505-01-S12-L3	VG-505-02-S12-L3	1/2-13		S	3.74"
VG-505-01-P12-L5	VG-505-02-P12-L5	1/2-13	P		5.93"
VG-505-01-S12-L5	VG-505-02-S12-L5	1/2-13		S	5.93"
VG-505-01-P58-L3	VG-505-02-P58-L3	5/8-11	P		3.74"
VG-505-01-S58-L3	VG-505-02-S58-L3	5/8-11		S	3.74"
VG-505-01-P58-L5	VG-505-02-P58-L5	5/8-11	P		5.93"
VG-505-01-S58-L5	VG-505-02-S58-L5	5/8-11		S	5.93"
VG-505-01-PM10-L3	VG-505-02-PM10-L3	M10	P		3.74"
VG-505-01-SM10-L3	VG-505-02-SM10-L3	M10		S	3.74"
VG-505-01-PM12-L3	-	M12	P		3.74"
VG-505-01-SM12-L3	VG-505-02-SM12-L3	M12		S	3.74"
VG-505-01-PM12-L5	VG-505-02-PM12-L5	M12	P		5.93"
VG-505-01-SM12-L5	VG-505-02-SM12-L5	M12		S	5.93"
VG-505-01-PM16-L3	VG-505-02-PM16-L3	M16	P		3.74"
VG-505-01-SM16-L3	VG-505-02-SM16-L3	M16		S	3.74"
VG-505-01-PM16-L5	VG-505-02-PM16-L5	M16	P		5.93"
VG-505-01-SM16-L5	VG-505-02-SM16-L5	M16		S	5.93"

Sanitary

NOTE: The VG-505-01 style levelers (without lag holes) are available with the underside cavity entirely and permanently filled with urethane, adding 1/8" to the leveler height. Please specify by replacing base style -01 with a -U1 in the part number: VG-505-01-P12-L3 becomes VG-505-U1-P12-L3



The urethane filling completely seals the bottom of the leveler, eliminating entrapment areas that can harbor bacterial growth. The material also has a vibration dampening effect and is extremely skid resistant.

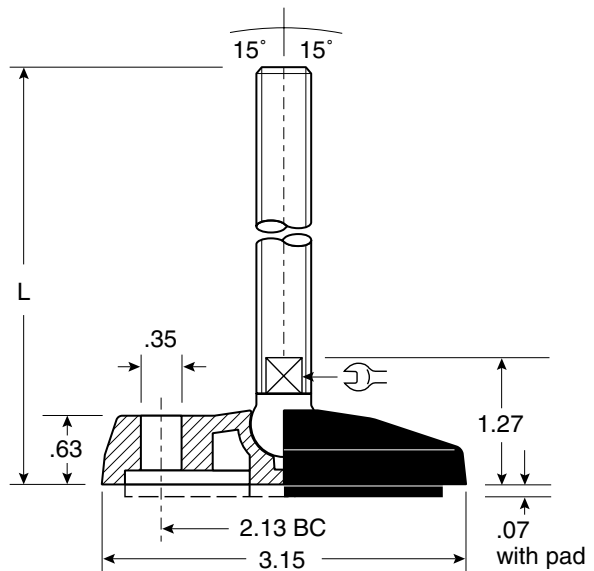



511

Articulating Leveler

Conveyor and machinery support.

Maximum Recommended Static Load: 2600 lbs.

Includes 2:1 safety factor.



VG-511-01-

VG-511-02-

VG-511-03-

VG-511-04-

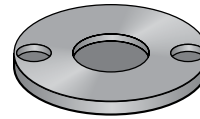
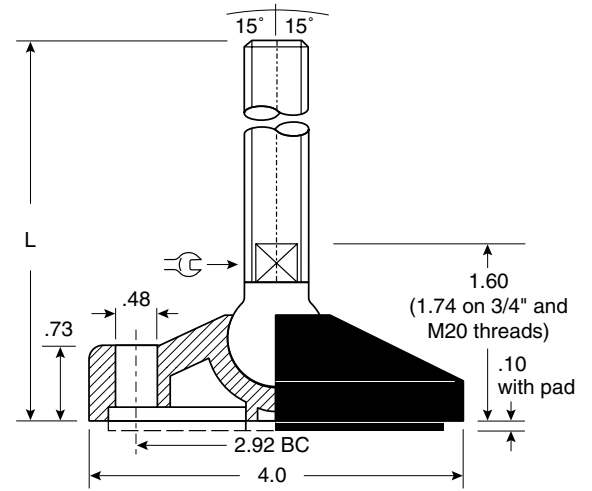

VG-512 Vibration Pad

Neoprene rubber.

Fits any VG-511 series leveler.

Sold separately. See page 363.

Machine & Equip. Components

Base Material: Reinforced polyamide							
Without Lag Holes	With Two Lag Holes	Stem With One Lag Hole	Stem Material With Skinned Lag Holes	Thread	Zinc	Stainless	"L" Dim
VG-511-01-P12-L3	VG-511-02-P12-L3	VG-511-03-P12-L3	-	1/2-13	P		4.52"
VG-511-01-S12-L3	VG-511-02-S12-L3	VG-511-03-S12-L3	VG-511-04-S12-L3	1/2-13		S	4.52"
VG-511-01-P12-L5	VG-511-02-P12-L5	VG-511-03-P12-L5	VG-511-04-P12-L5	1/2-13	P		6.20"
VG-511-01-S12-L5	VG-511-02-S12-L5	VG-511-03-S12-L5	VG-511-04-S12-L5	1/2-13		S	6.20"
VG-511-01-P58-L3	VG-511-02-P58-L3	VG-511-03-P58-L3	VG-511-04-P58-L3	5/8-11	P		4.52"
VG-511-01-S58-L3	VG-511-02-S58-L3	VG-511-03-S58-L3	VG-511-04-S58-L3	5/8-11		S	4.52"
VG-511-01-P58-L5	VG-511-02-P58-L5	VG-511-03-P58-L5	VG-511-04-P58-L5	5/8-11	P		6.20"
VG-511-01-S58-L5	VG-511-02-S58-L5	VG-511-03-S58-L5	VG-511-04-S58-L5	5/8-11		S	6.20"
VG-511-01-P58-L7	VG-511-02-P58-L7	VG-511-03-P58-L7	VG-511-04-P58-L7	5/8-11	P		7.69"
VG-511-01-S58-L7	VG-511-02-S58-L7	VG-511-03-S58-L7	VG-511-04-S58-L7	5/8-11		S	7.69"
VG-511-01-P34-L5	VG-511-02-P34-L5	VG-511-03-P34-L5	VG-511-04-P34-L5	3/4-10	P		6.20"
VG-511-01-S34-L5	VG-511-02-S34-L5	VG-511-03-S34-L5	VG-511-04-S34-L5	3/4-10		S	6.20"
VG-511-01-P34-L7	VG-511-02-P34-L7	VG-511-03-P34-L7	VG-511-04-P34-L7	3/4-10	P		7.69"
VG-511-01-S34-L7	VG-511-02-S34-L7	VG-511-03-S34-L7	VG-511-04-S34-L7	3/4-10		S	7.69"
VG-511-01-P34-L10	VG-511-02-P34-L10	VG-511-03-P34-L10	VG-511-04-P34-L10	3/4-10	P		10.69"
VG-511-01-S34-L10	VG-511-02-S34-L10	VG-511-03-S34-L10	VG-511-04-S34-L10	3/4-10		S	10.69"
VG-511-01-PM12-L3	VG-511-02-PM12-L3	VG-511-03-PM12-L3	-	M12	P		4.52"
VG-511-01-PM16-L3	VG-511-02-PM16-L3	VG-511-03-PM16-L3	-	M16	P		4.52"
VG-511-01-SM16-L3	VG-511-02-SM16-L3	VG-511-03-SM16-L3	VG-511-04-SM16-L3	M16		S	4.52"
VG-511-01-PM16-L5	VG-511-02-PM16-L5	VG-511-03-PM16-L5	-	M16	P		6.20"
VG-511-01-SM16-L5	VG-511-02-SM16-L5	VG-511-03-SM16-L5	VG-511-04-SM16-L5	M16		S	6.20"
VG-511-01-PM16-L7	VG-511-02-PM16-L7	VG-511-03-PM16-L7	VG-511-04-PM16-L7	M16	P		7.69"
VG-511-01-SM16-L7	VG-511-02-SM16-L7	VG-511-03-SM16-L7	VG-511-04-SM16-L7	M16		S	7.69"
VG-511-01-SM20-L5	VG-511-02-SM20-L5	-	VG-511-04-SM20-L5	M20		S	6.20"
VG-511-01-PM20-L7	VG-511-02-PM20-L7	VG-511-03-PM20-L7	-	M20	P		7.69"
VG-511-01-SM20-L7	VG-511-02-SM20-L7	VG-511-03-SM20-L7	VG-511-04-SM20-L7	M20		S	7.69"

Adjustable Levelers — Medium Duty



VG-511H-01-

VG-511H-02-

VG-511H-03-

VG-511H-04-

511H

Articulating Leveler

Conveyor and machinery support.

Maximum Recommended

Static Load: 2600 lbs.

Includes 2:1 safety factor.

Base Material: Reinforced polyamide

Without Lag Holes	With Two Lag Holes	With One Lag Hole	Stem With Skinned Lag Holes	Stem Thread	Material Zinc Stainless	"L" Dim
VG-511H-01-P58-L5	-	-	VG-511H-04-P58-L5	5/8-11	P	5.73"
VG-511H-01-S58-L5	VG-511H-02-S58-L5	VG-511H-03-S58-L5	VG-511H-04-S58-L5	5/8-11	S	6.15"
VG-511H-01-P58-L7	VG-511H-02-P58-L7	VG-511H-03-P58-L7	-	5/8-11	P	7.31"
VG-511H-01-S58-L7	VG-511H-02-S58-L7	VG-511H-03-S58-L7	VG-511H-04-S58-L7	5/8-11	S	7.69"
VG-511H-01-P34-L5	VG-511H-02-P34-L5	VG-511H-03-P34-L5	-	3/4-10	P	6.15"
VG-511H-01-S34-L5	VG-511H-02-S34-L5	VG-511H-03-S34-L5	VG-511H-04-S34-L5	3/4-10	S	6.15"
-	VG-511H-02-P34-L7	VG-511H-03-P34-L7	VG-511H-04-P34-L7	3/4-10	P	7.69"
VG-511H-01-S34-L7	VG-511H-02-S34-L7	VG-511H-03-S34-L7	VG-511H-04-S34-L7	3/4-10	S	7.69"
VG-511H-01-P34-L10	VG-511H-02-P34-L10	VG-511H-03-P34-L10	-	3/4-10	P	9.95"
VG-511H-01-S34-L10	VG-511H-02-S34-L10	VG-511H-03-S34-L10	VG-511H-04-S34-L10	3/4-10	S	9.95"
VG-511H-01-P100-L7	VG-511H-02-P100-L7	VG-511H-03-P100-L7	VG-511H-04-P100-L7	1-8	P	7.69"
VG-511H-01-S100-L7	VG-511H-02-S100-L7	VG-511H-03-S100-L7	VG-511H-04-S100-L7	1-8	S	7.69"
VG-511H-01-P100-L10	VG-511H-02-P100-L10	VG-511H-03-P100-L10	-	1-8	P	9.95"
VG-511H-01-S100-L10	VG-511H-02-S100-L10	VG-511H-03-S100-L10	VG-511H-04-S100-L10	1-8	S	9.95"
VG-511H-01-SM20-L7	VG-511H-02-SM20-L7	VG-511H-03-SM20-L7	VG-511H-04-SM20-L7	M20	S	7.69"
VG-511H-01-SM20-L10	VG-511H-02-SM20-L10	-	VG-511H-04-SM20-L10	M20	S	9.95"
VG-511H-01-PM24-L7	VG-511H-02-PM24-L7	-	-	M24	P	7.69"
VG-511H-01-SM24-L7	VG-511H-02-SM24-L7	-	VG-511H-04-SM24-L7	M24	S	7.69"

Machine & Equip. Components



Sanitary

NOTE: The VG-511-01 or VG-511H-01 style levelers (without lag holes) are available with the underside cavity entirely and permanently filled with urethane, adding 1/8" to the leveler height. Please specify by replacing base style -01 with a -U1 in the part number:

VG-511-01-P58-L7 becomes VG-511-U1-P58-L7

The urethane filling completely seals the bottom of the leveler, eliminating entrapment areas that can harbor bacterial growth. The material also has a vibration dampening effect and is extremely skid resistant.

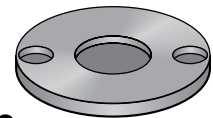

VG-512 Vibration Pad

Neoprene rubber.

Fits any VG-511 series leveler.

Sold separately. See page 363.

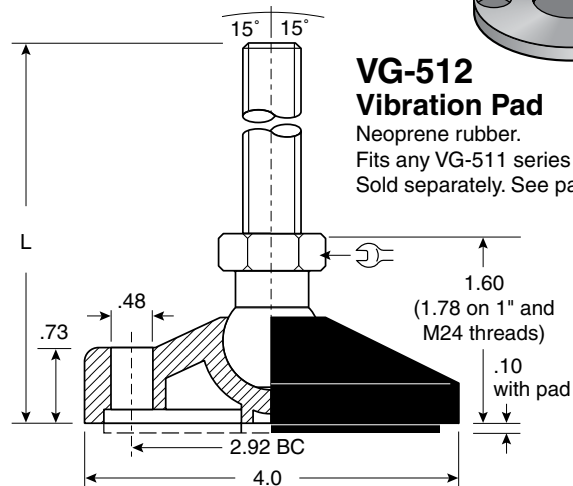



511-T

Loc-A-Lign™ Series Articulating Leveler

Conveyor and machinery support where resistance to stem pull-out is required.

**Maximum Recommended
Static Load: 2600 lbs.**
Includes 2:1 safety factor.



Base Material: Reinforced polyamide.
Loc-A-Lign fastener: Stainless steel or zinc plated

Without Lag Holes	With Two Lag Holes	With One Lag Hole	With Skinned Lag Holes	Stem Thread	Stem Material Zinc Stainless	"L" Dim
VG-511-01-P12-L5T	VG-511-02-P12-L5T	VG-511-03-P12-L5T	-	1/2-13	P	6.20"
VG-511-01-S12-L5T	VG-511-02-S12-L5T	VG-511-03-S12-L5T	-	1/2-13	S	6.20"
-	VG-511-02-P58-L5T	VG-511-03-P58-L5T	VG-511-04-P58-L5T	5/8-11	P	6.20"
VG-511-01-S58-L5T	VG-511-02-S58-L5T	VG-511-03-S58-L5T	VG-511-04-S58-L5T	5/8-11	S	6.20"
VG-511-01-P58-L7T	VG-511-02-P58-L7T	VG-511-03-P58-L7T	VG-511-04-P58-L7T	5/8-11	P	7.69"
VG-511-01-S58-L7T	VG-511-02-S58-L7T	VG-511-03-S58-L7T	VG-511-04-S58-L7T	5/8-11	S	7.69"
VG-511-01-P34-L5T	VG-511-02-P34-L5T	VG-511-03-P34-L5T	-	3/4-10	P	6.20"
-	VG-511-02-S34-L5T	VG-511-03-S34-L5T	VG-511-04-S34-L5T	3/4-10	S	6.20"
VG-511-01-P34-L7T	VG-511-02-P34-L7T	VG-511-03-P34-L7T	VG-511-04-P34-L7T	3/4-10	P	7.69"
VG-511-01-S34-L7T	VG-511-02-S34-L7T	VG-511-03-S34-L7T	VG-511-04-S34-L7T	3/4-10	S	7.69"
VG-511-01-P34-L10T	VG-511-02-P34-L10T	-	-	3/4-10	P	10.69"
VG-511-01-S34-L10T	VG-511-02-S34-L10T	VG-511-03-S34-L10T	VG-511-04-S34-L10T	3/4-10	S	10.69"
-	VG-511-02-PM16-L5T	VG-511-03-PM16-L5T	-	M16	P	6.20"
VG-511-01-SM16-L5T	VG-511-02-SM16-L5T	VG-511-03-SM16-L5T	VG-511-04-SM16-L5T	M16	S	6.20"
VG-511-01-PM16-L7T	-	VG-511-03-PM16-L7T	VG-511-04-PM16-L7T	M16	P	7.69"
VG-511-01-SM16-L7T	VG-511-02-SM16-L7T	VG-511-03-SM16-L7T	VG-511-04-SM16-L7T	M16	S	7.69"
VG-511-01-SM20-L7T	VG-511-02-SM20-L7T	VG-511-03-SM20-L7T	VG-511-04-SM20-L7T	M20	S	7.69"
-	VG-511-02-PM20-L10T	VG-511-03-PM20-L10T	-	M20	P	10.69"
VG-511-01-SM20-L10T	VG-511-02-SM20-L10T	VG-511-03-SM20-L10T	-	M20	S	10.69"

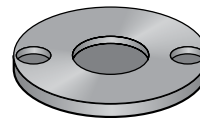
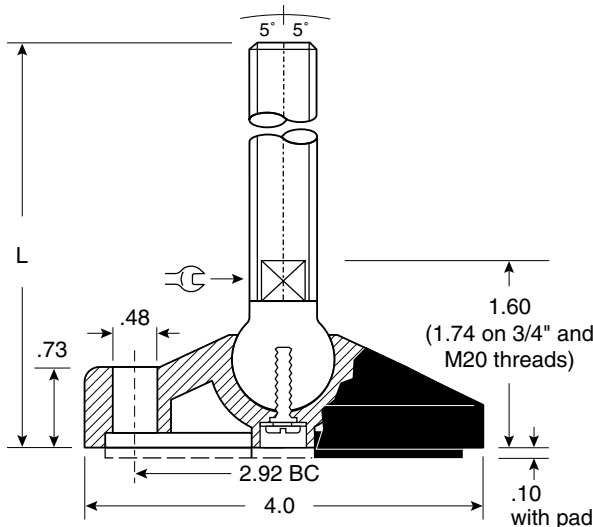

VG-512 Vibration Pad

Neoprene rubber.
Fits any VG-511 series leveler.
Sold separately. See page 363.

Machine & Equip.
Components

Adjustable Levelers — Medium Duty



511H-T

Articulating Leveler

Conveyor and machinery support.

Maximum Recommended Static Load: 2600 lbs.

Includes 2:1 safety factor.



Base Material: Reinforced polyamide

Without Lag Holes	With Two Lag Holes	With One Lag Hole	With Skinned Lag Holes	Stem Thread	Stem Material Zinc Stainless	"L" Dim
VG-511H-01-P58-L5T	VG-511H-02-P58-L5T	VG-511H-03-P58-L5T	-	5/8-11	P	5.73"
VG-511H-01-S58-L5T	VG-511H-02-S58-L5T	VG-511H-03-S58-L5T	VG-511H-04-S58-L5T	5/8-11	S	6.15"
-	-	-	VG-511H-04-S58-L7T	5/8-11	S	7.69"
VG-511H-01-S34-L5T	-	-	VG-511H-04-S34-L5T	3/4-10	S	6.15"
VG-511H-01-S34-L7T	VG-511H-02-S34-L7T	VG-511H-03-S34-L7T	VG-511H-04-S34-L7T	3/4-10	S	7.69"
-	VG-511H-02-S34-L10T	VG-511H-03-S34-L10T	VG-511H-04-S34-L10T	3/4-10	S	9.95"
VG-511H-01-P100-L7T	-	-	-	1-8	P	7.69"
-	VG-511H-02-S100-L7T	VG-511H-03-S100-L7T	VG-511H-04-S100-L7T	1-8	S	7.69"
VG-511H-01-S100-L10T	VG-511H-02-S100-L10T	VG-511H-03-S100-L10T	VG-511H-04-S100-L10T	1-8	S	9.95"
VG-511H-01-SM20-L5T	VG-511H-02-SM20-L5T	-	-	M20	S	6.15"
VG-511H-01-PM20-L7T	VG-511H-02-PM20-L7T	VG-511H-03-PM20-L7T	VG-511H-04-PM20-L7T	M20	P	7.69"
-	VG-511H-02-SM20-L7T	VG-511H-03-SM20-L7T	VG-511H-04-SM20-L7T	M20	S	7.69"
-	VG-511H-02-PM20-L10T	-	-	M20	P	9.95"
VG-511H-01-SM20-L10T	VG-511H-02-SM20-L10T	-	-	M20	S	9.95"

Machine & Equip. Components

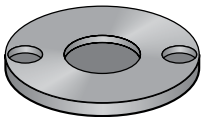

VG-512 Vibration Pad

Neoprene rubber.
Fits any VG-511 series leveler.
Sold separately. See page 363.

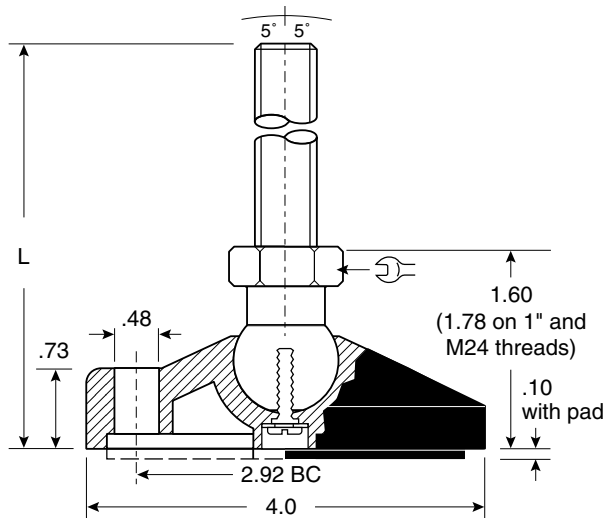



513

Articulating Leveler Machinery Support

Maximum Recommended
Static Load: 4400 lbs.
Includes 2:1 safety factor.

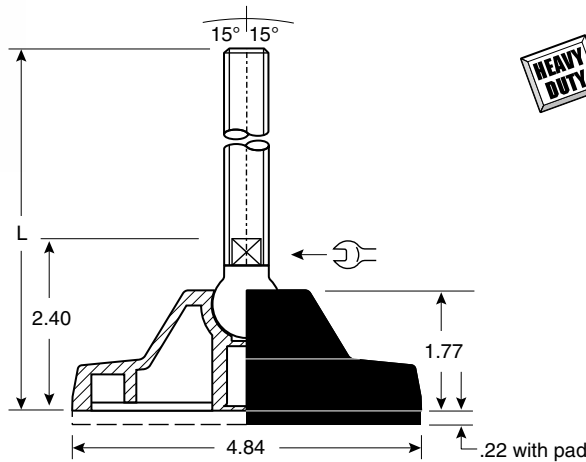

Base Material: Reinforced polyamide

Part Number	Stem Thread	Stem Material		"L" Dim
		Zinc	Stainless	
VG-513-01-P34-L5	3/4-10	P		7.03"
VG-513-01-S34-L5	3/4-10		S	7.03"
VG-513-01-P34-L8	3/4-10	P		8.55"
VG-513-01-S34-L8	3/4-10		S	8.55"
VG-513-01-SM20-L5	M20		S	7.03"
VG-513-01-PM20-L8	M20	P		8.55"
VG-513-01-SM20-L8	M20		S	8.55"

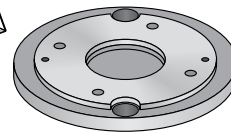

VG-514 Vibration Pad

Neoprene rubber with steel plate for even weight distribution. Sold separately. See page 363. Max. load: 7000 lbs.

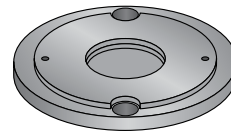

VG-514N Vibration Pad

Neoprene rubber for even weight distribution. Sold separately. See page 363. Max. load: 2600 lbs.



513H

Articulating Leveler Machinery Support

Maximum Recommended
Static Load: 4400 lbs.
Includes 2:1 safety factor.

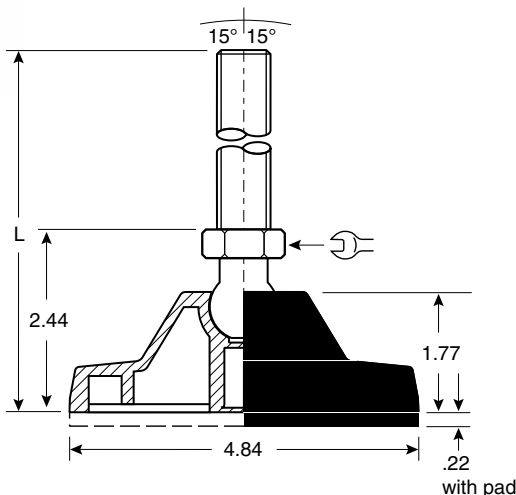

Base Material: Reinforced polyamide

Part Number	Stem Thread	Stem Material		"L" Dim
		Zinc	Stainless	
VG-513H-01-P34-L5	3/4-10	P		7.03"
VG-513H-01-S34-L5	3/4-10		S	7.03"
VG-513H-01-P34-L7	3/4-10	P		8.55"
VG-513H-01-S34-L7	3/4-10		S	8.55"
VG-513H-01-P34-L10	3/4-10	P		10.83"
VG-513H-01-S34-L10	3/4-10		S	10.83"
VG-513H-01-P100-L7	1-8	P		8.55"
VG-513H-01-S100-L7	1-8		S	8.55"
VG-513H-01-P100-L10	1-8	P		10.83"
VG-513H-01-S100-L10	1-8		S	10.83"
VG-513H-01-PM20-L8	M20	P		8.55"
VG-513H-01-SM20-L8	M20		S	8.55"
VG-513H-01-PM20-L10	M20	P		10.83"
VG-513H-01-PM24-L8	M24	P		8.55"
VG-513H-01-SM24-L8	M24		S	8.55"
VG-513H-01-SM24-L10	M24		S	10.83"

Machine & Equip. Components

Adjustable Levelers — Heavy Duty

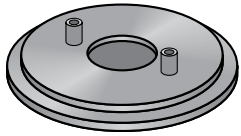

VG-516 Vibration Pad

Flexible PVC. Fits any VG-518 series leveler. Sold separately. See page 363.

518

Support Leveler Machinery Support

Maximum Recommended Static Load: 4000 lbs.
Includes 2:1 safety factor.

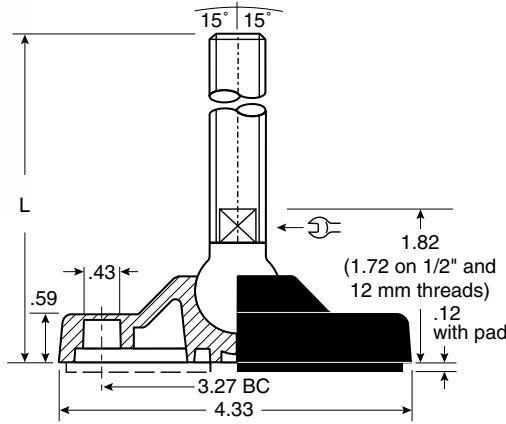

Base Material: Reinforced polyamide

Part Number	Stem Thread	Stem Material		"L" Dim
		Zinc	Stainless	
VG-518-01-S12-L3	1/2-13		S	4.68"
VG-518-01-P12-L5	1/2-13	P		6.36"
VG-518-01-S12-L5	1/2-13		S	6.36"
VG-518-01-P58-L3	5/8-11	P		4.68"
VG-518-01-S58-L3	5/8-11		S	4.68"
VG-518-01-P58-L5	5/8-11	P		6.36"
VG-518-01-S58-L5	5/8-11		S	6.36"
VG-518-01-P58-L7	5/8-11	P		7.85"
VG-518-01-S58-L7	5/8-11		S	7.85"
VG-518-01-P34-L5	3/4-10	P		6.36"
VG-518-01-S34-L5	3/4-10		S	6.36"
VG-518-01-P34-L7	3/4-10	P		7.85"
VG-518-01-S34-L7	3/4-10		S	7.85"
VG-518-01-P34-L10	3/4-10	P		10.85"
VG-518-01-S34-L10	3/4-10		S	10.85"
VG-518-01-PM12-L3	M12	P		4.68"
VG-518-01-PM16-L5	M16	P		6.36"
VG-518-01-SM16-L5	M16		S	6.36"
VG-518-01-PM16-L7	M16	P		7.85"
VG-518-01-SM16-L7	M16		S	7.85"
VG-518-01-SM20-L7	M20		S	7.85"

518H

Support Leveler Machinery Support

Maximum Recommended Static Load: 4000 lbs.
Includes 2:1 safety factor.

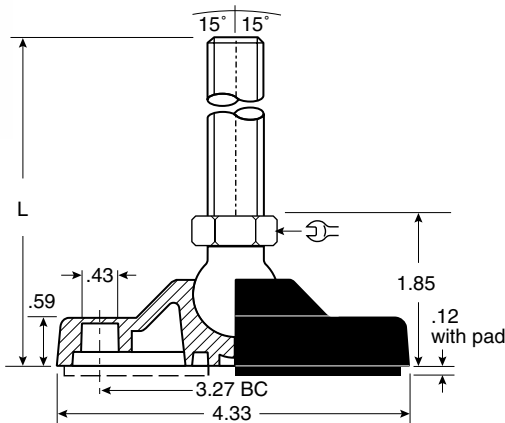

Part Number	Stem Thread	Stem Material		"L" Dim
		Zinc	Stainless	
VG-518H-01-P34-L5	3/4-10	P		6.29"
VG-518H-01-S34-L5	3/4-10		S	6.29"
VG-518H-01-P34-L7	3/4-10	P		7.83"
VG-518H-01-S34-L7	3/4-10		S	7.83"
VG-518H-01-P34-L10	3/4-10	P		10.09"
VG-518H-01-S34-L10	3/4-10		S	10.09"
VG-518H-01-P100-L7	1-8	P		7.83"
VG-518H-01-S100-L7	1-8		S	7.83"
VG-518H-01-P100-L10	1-8	P		10.09"
VG-518H-01-S100-L10	1-8		S	10.09"
VG-518H-01-SM20-L8	M20		S	7.83"
VG-518H-01-SM20-L10	M20		S	10.09"

VG-516 Vibration Pad

Flexible PVC. Fits any VG-518 series leveler. Sold separately. See page 363.

Machine & Equip. Components

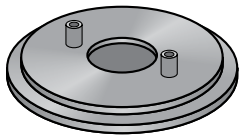
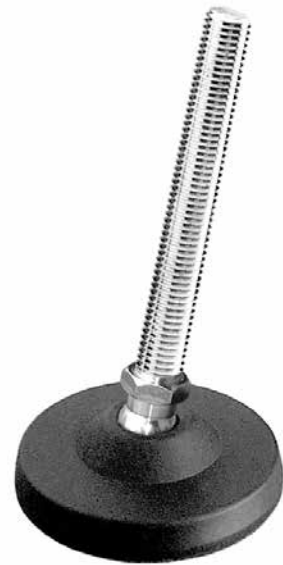



517-K

Support Leveler
Machinery Support

Maximum Recommended Static Load: 7000 lbs.
Includes 2:1 safety factor.

Base Material: Reinforced polyamide

Part Number	Stem Thread	Stem Material		"L" Dim
		Zinc	Stainless	
VG-517-01-P34-L7K	3/4-10	P		7.50"
VG-517-01-S34-L7K	3/4-10		S	7.50"
VG-517-01-P100-L7K	1-8	P		7.48"
VG-517-01-S100-L7K	1-8		S	7.48"
VG-517-01-P113-L7K	1 1/8-7	P		7.48"
VG-517-01-S113-L7K	1 1/8-7		S	7.48"
VG-517-01-S125-L7K	1 1/4-7		S	7.48"
VG-517-01-SM20-L7K	M20		S	7.48"

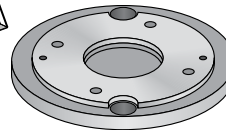
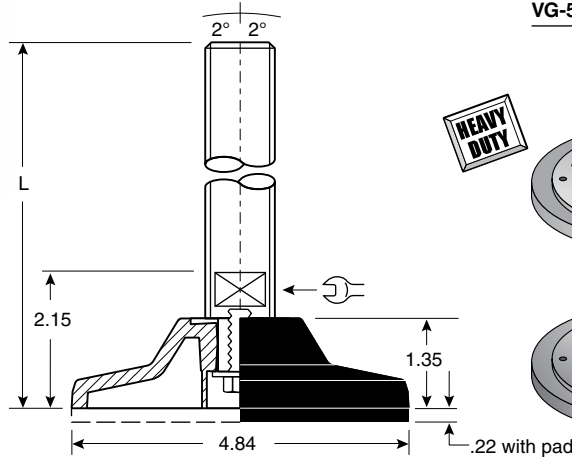

VG-514 Vibration Pad

Neoprene rubber with steel plate for even weight distribution. Sold separately. See page 363. Max. load: 7000 lbs.

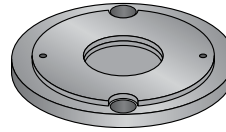

VG-514N Vibration Pad

Neoprene rubber for even weight distribution. Sold separately. See page 363. Max. load: 2600 lbs.



520



Support Leveler
Machinery Support with adjusting nut welded to stem.

Maximum Recommended Static Load: 7000 lbs.
Includes 2:1 safety factor.

Base Material: Reinforced polyamide

Part Number	Stem Thread	Stem Material		"L" Dim
		Zinc	Stainless	
VG-520-02-P34-L5	3/4-10	P		5.97"
VG-520-02-S34-L5	3/4-10		S	5.97"
VG-520-02-P34-L7	3/4-10	P		7.48"
VG-520-02-S34-L7	3/4-10		S	7.48"
VG-520-02-P34-L10	3/4-10	P		10.07"
VG-520-02-S34-L10	3/4-10		S	10.07"
VG-520-02-P100-L7	1-8	P		7.48"
VG-520-02-S100-L7	1-8		S	7.48"
VG-520-02-P100-L10	1-8	P		10.07"
VG-520-02-S100-L10	1-8		S	10.07"
VG-520-02-PM20-L7	M20	P		7.48"
VG-520-02-SM20-L7	M20		S	7.48"
VG-520-02-SM20-L10	M20		S	10.07"
VG-520-02-PM24-L7	M24	P		7.48"
VG-520-02-PM24-L10	M24	P		10.07"
VG-520-02-SM24-L10	M24		S	10.07"

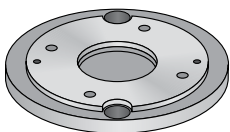
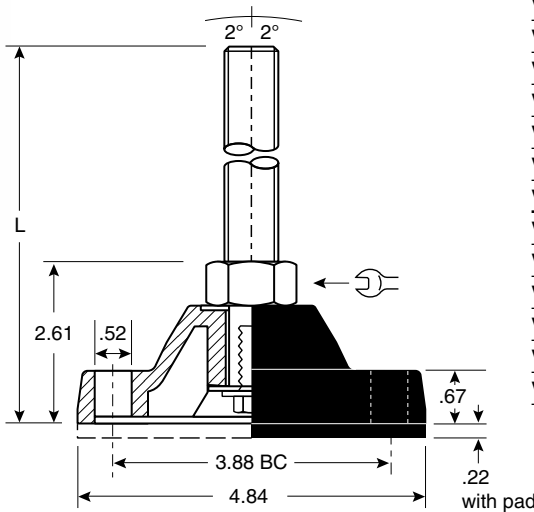

VG-514 Vibration Pad

Neoprene rubber with steel plate for even weight distribution. Sold separately. See page 363. Max. load: 7000 lbs.

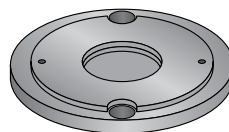

VG-514N Vibration Pad

Neoprene rubber for even weight distribution. Sold separately. See page 363. Max. load: 2600 lbs.

Machine & Equip. Components

Adjustable Levelers — Heavy Duty

520-K

Support Leveler Machinery Support

**Maximum Recommended
Static Load: 7000 lbs.**
Includes 2:1 safety factor.

Base Material: Reinforced polyamide

Part Number	Stem Thread	Stem Material		"L" Dim
		Zinc	Stainless	
VG-520-02-P34-L7K	3/4-10	P		7.50"
VG-520-02-S34-L7K	3/4-10		S	7.50"
VG-520-02-P100-L7K	1-8	P		7.50"
VG-520-02-S100-L7K	1-8		S	7.50"
VG-520-02-P113-L7K	1 1/8-7	P		7.50"
VG-520-02-S113-L7K	1 1/8-7		S	7.50"
VG-520-02-S125-L7K	1 1/4-7		S	7.50"
VG-520-02-SM20-L7K	M20		S	7.50"

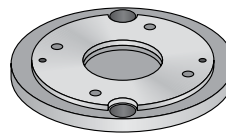
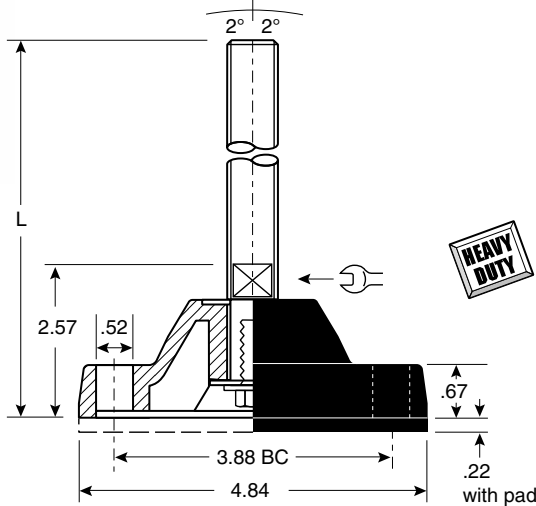

VG-514 Vibration Pad

Neoprene rubber with steel plate for even weight distribution. Sold separately. See page 363. Max. load: 7000 lbs.

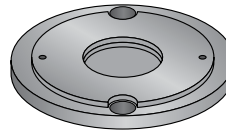

VG-514N Vibration Pad

Neoprene rubber for even weight distribution. Sold separately. See page 363. Max. load: 2600 lbs.

520-T

Loc-A-Lign™ Series Articulating Leveler

Conveyor and machinery support where resistance to stem pull-out is required.

**Maximum Recommended
Static Load: 7000 lbs.**
Includes 2:1 safety factor.

Base Material: Reinforced polyamide

Loc-A-Lign fastener: Stainless steel or zinc plated

Part Number	Stem Thread	Stem Material		"L" Dim
		Zinc	Stainless	
VG-520-02-P100-L7T	1-8	P		7.45"
VG-520-02-S100-L7T	1-8		S	7.45"
VG-520-02-P100-L10T	1-8	P		9.95"
VG-520-02-S100-L10T	1-8		S	9.95"
VG-520-02-P100-L12T	1-8	P		11.95"
VG-520-02-S100-L12T	1-8		S	11.95"
VG-520-02-P113-L7T	1 1/8-7	P		7.45"
VG-520-02-S113-L7T	1 1/8-7		S	7.45"
VG-520-02-P113-L10T	1 1/8-7	P		9.95"
VG-520-02-S113-L10T	1 1/8-7		S	9.95"
VG-520-02-S125-L7T	1 1/4-7		S	7.45"
VG-520-02-S125-L10T	1 1/4-7		S	9.95"
VG-520-02-P125-L12T	1 1/4-7	P		11.95"
VG-520-02-S125-L12T	1 1/4-7		S	11.95"
VG-520-02-SM24-L7T	M24		S	7.45"

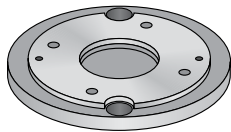
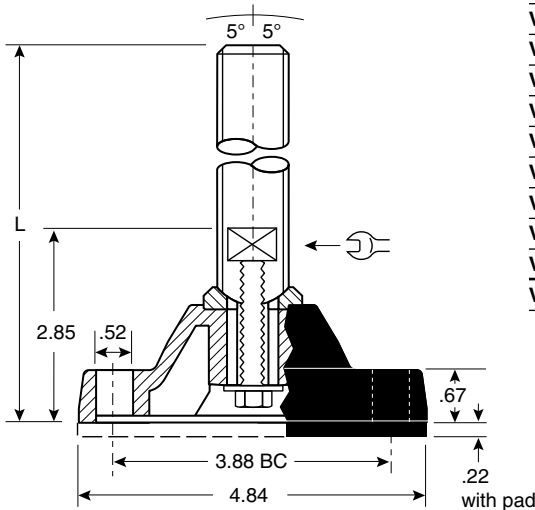

VG-514 Vibration Pad

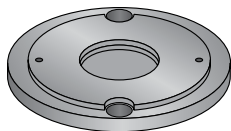

VG-514N Vibration Pad

Machine & Equip.
Components

Adjustable Levelers — Solid Bases



Vibration Pads for Adjustable Levelers

Vibration and skid reduction.
Neoprene Shore: A70-80

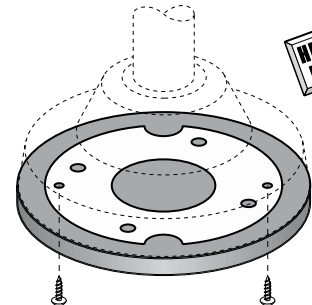
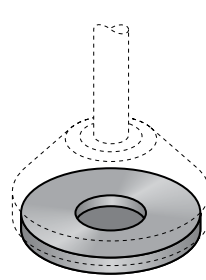

HEAVY DUTY

Press in type: Neoprene rubber.

Screw in type: Rubber and metal

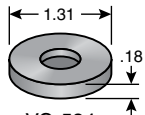

VG-534
For use with:
VG-533 series

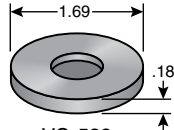

VG-538
For use with:
VG-537 series

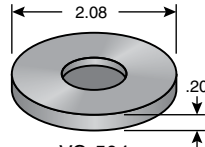

VG-504
For use with:
VG-501 series

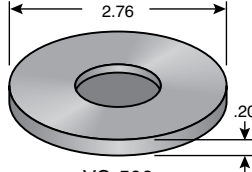

VG-506
For use with:
VG-505 series

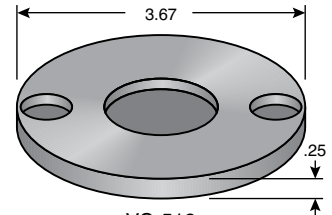

VG-512
For use with:
VG-511 series

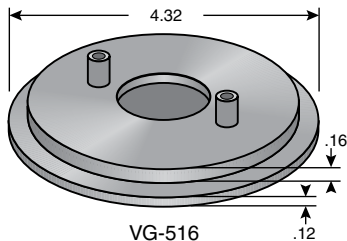

VG-516
For use with:
VG-518 series

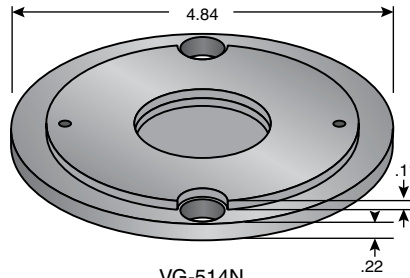

VG-514N
For use with: VG-513 series,
VG-517-K series, VG-520 series.
Max. load: 2600 lbs.

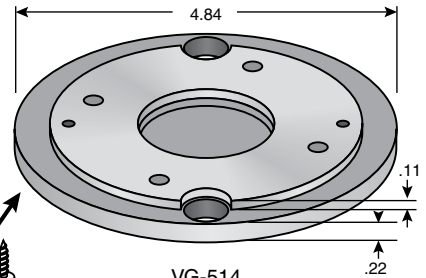

VG-514
For use with: VG-513 series,
VG-517-K series, VG-520 series.
Max. load: 7000 lbs.



501D

Articulating Leveler with Solid Base

Conveyor and machinery support

Maximum Recommended
Static Load: 3000 lbs.
Includes 2:1 safety factor.



VG-501D-01-S12-L3

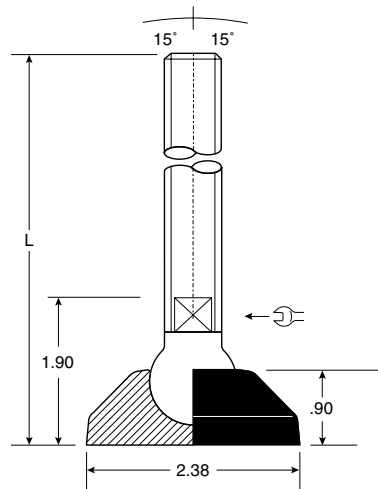
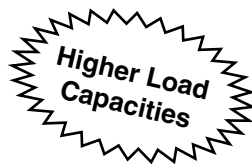

The new solid base design will support heavier loads and does not have any cavities in the base material.

Base Material: Reinforced polyamide

Part Number	Stem Thread	Stem Material	"L" Dim
VG-501D-01-P12-L3	1/2-13	P	4.54"
VG-501D-01-S12-L3	1/2-13	S	4.54"
VG-501D-01-P58-L3	5/8-11	P	4.54"
VG-501D-01-S58-L3	5/8-11	S	4.54"
VG-501D-01-P58-L8	5/8-11	P	7.71"
VG-501D-01-S58-L8	5/8-11	S	7.71"
VG-501D-01-P34-L8	3/4-10	P	7.71"
VG-501D-01-S34-L8	3/4-10	S	7.71"
VG-501D-01-P34-L10	3/4-10	P	10.71"
VG-501D-01-S34-L10	3/4-10	S	10.71"
VG-501D-01-SM12-L3	M12	S	4.51"
VG-501D-01-PM16-L3	M16	P	4.51"
VG-501D-01-SM16-L3	M16	S	4.51"
VG-501D-01-PM16-L8	M16	P	7.71"
VG-501D-01-SM16-L8	M16	S	7.71"
VG-501D-01-SM20-L8	M20	S	7.71"

Machine & Equip. Components



Adjustable Levelers — Solid Bases



505D

Articulating Leveler with Solid Base

Conveyor and machinery support.

Maximum Recommended Static Load: 3000 lbs. Includes 2:1 safety factor.

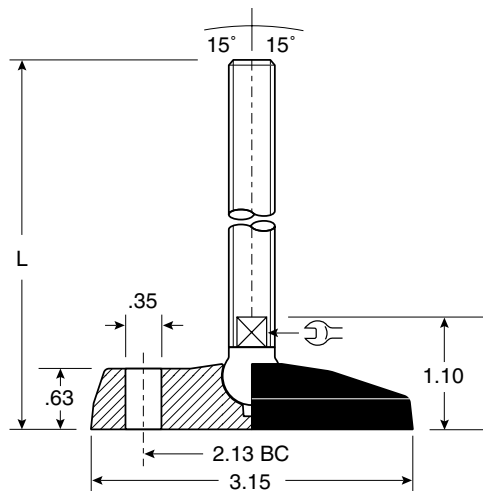

The new solid base design will support heavier loads, and does not have any cavities in the base material.

Base Material: Reinforced polyamide

Part Number With Two Lag Holes	Stem Thread	Stem Material		"L" Dim
		Zinc	Stainless	
VG-505D-02-P38-L3	3/8-16	P		3.74"
VG-505D-02-S38-L3	3/8-16		S	3.74"
VG-505D-02-P12-L3	1/2-13	P		3.74"
VG-505D-02-S12-L3	1/2-13		S	3.74"
VG-505D-02-P12-L5	1/2-13	P		5.93"
VG-505D-02-S12-L5	1/2-13		S	5.93"
VG-505D-02-P58-L3	5/8-11	P		3.74"
VG-505D-02-S58-L3	5/8-11		S	3.74"
VG-505D-02-P58-L5	5/8-11	P		5.93"
VG-505D-02-S58-L5	5/8-11		S	5.93"
VG-505D-02-SM10-L3	M10		S	3.74"
VG-505D-02-SM12-L5	M12		S	5.93"
VG-505D-02-PM16-L3	M16	P		3.74"
VG-505D-02-SM16-L3	M16		S	3.74"
VG-505D-02-PM16-L5	M16	P		5.93"
VG-505D-02-SM16-L5	M16		S	5.93"

Machine & Equip.
Components

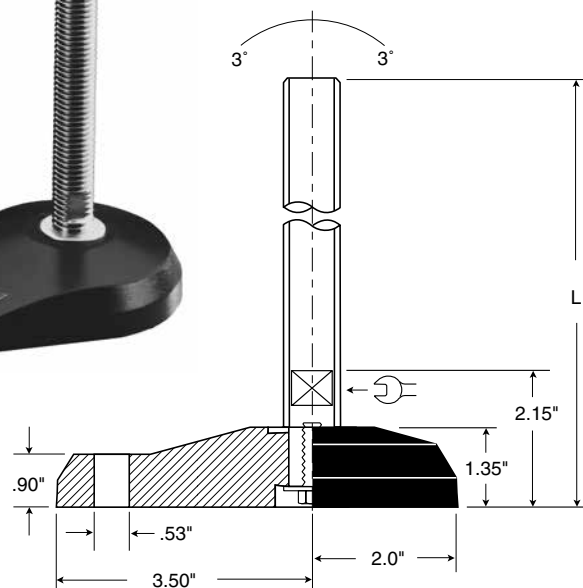
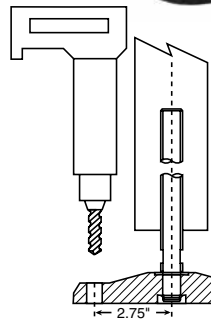

The lag hole is offset enough to allow sufficient clearance for the use of a heavy duty drill.

525

Support Leveler with Solid Base

Machinery support where lag hole accessibility or high chemical resistance is required.

Maximum Recommended Static Load: 7200 lbs.
Includes 2:1 safety factor.

Base Material: Reinforced polyamide

Part Number	Stem Thread	Stem Material		"L" Dim
		Zinc	Stainless	
VG-525-02-P34-L7K	3/4-10	P		7.25"
VG-525-02-S34-L7K	3/4-10		S	7.25"
VG-525-02-P100-L7K	1-8	P		7.25"
VG-525-02-S100-L7K	1-8		S	7.25"
VG-525-02-P113-L7K	1 1/8-7	P		7.25"
VG-525-02-P125-L7K	1 1/4-7	P		7.25"
VG-525-02-S125-L7K	1 1/4-7		S	7.25"
VG-525-02-PM20-L7K	M20	P		7.25"
VG-525-02-SM20-L7K	M20		S	7.25"
VG-525-02-PM24-L7K	M24	P		7.25"
VG-525-02-SM24-L7K	M24		S	7.25"



501B

Socket Style

Conveyor and machinery support. Vibration pad sold separately. See page 363.

Maximum Recommended Static Load: 2000 lbs.
Includes 2:1 safety factor.

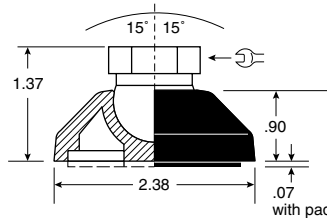

Base Material: Reinforced polyamide base, stainless steel threaded ball.

Part Number	Stem Thread
VG-501B-01-S12	1/2-13
VG-501B-01-S58	5/8-11
VG-501B-01-S34	3/4-10
VG-501B-01-SM16	M16

Valu Guide socket style levelers can be used on existing studs or with Valu Guide threaded rod to fabricate custom stem lengths.

511B

Socket Style

Conveyor and machinery support. Vibration pad sold separately. See page 363.

Maximum Recommended Static Load: 2600 lbs. Includes 2:1 safety factor.



VG-511B-01



VG-511B-03



VG-511B-02



VG-511B-04

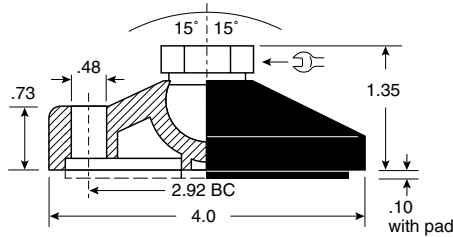

Materials: Reinforced polyamide base, stainless steel threaded ball.

Part Number				Stem Thread
Without Lag Holes	With One Lag Hole	With Two Lag Holes	With Skinned Lag Holes	
VG-511B-01-S12	VG-511B-03-S12	VG-511B-02-S12	VG-511B-04-S12	1/2-13
VG-511B-01-S58	VG-511B-03-S58	VG-511B-02-S58	VG-511B-04-S58	5/8-11
VG-511B-01-S34	VG-511B-03-S34	VG-511B-02-S34	VG-511B-04-S34	3/4-10

513B

Socket Style

Machinery support. Vibration pad sold separately. See page 363.

Maximum Recommended Static Load: 4400 lbs. Includes 2:1 safety factor.

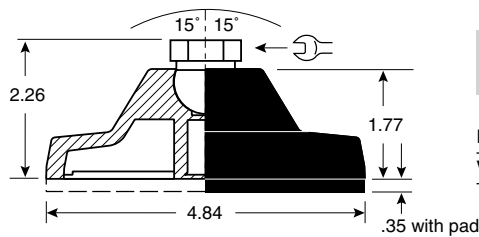

Materials: Reinforced polyamide base, stainless steel threaded ball.

Part Number	Stem Thread
VG-513B-01-S34	3/4-10

Machine & Equip. Components



Custom Leveler Request for Quote

Valu Guide will be pleased to quote on levelers manufactured to your special requirements. This page may be copied and used to fax or mail your specifications. Check the box next to the appropriate leveler and use the **Modification** section to denote the changes. For assistance, please contact Valu Guide customer service at 866-765-8744

Fax: 866-447-6587

Person Requesting Custom Information _____

Company Name _____

Address _____

City _____ State _____ Zip _____

Phone () _____ Fax () _____

Select Leveler to be Modified:

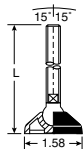
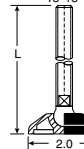
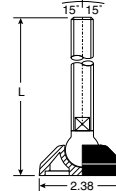
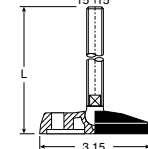
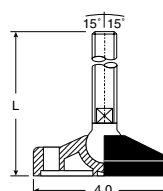
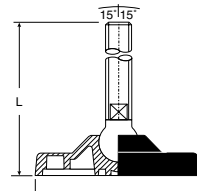
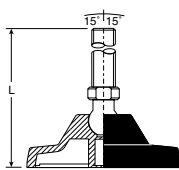
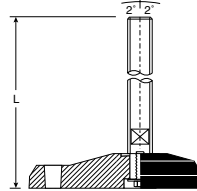
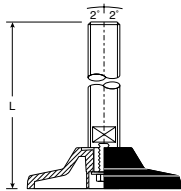
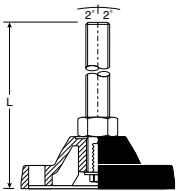
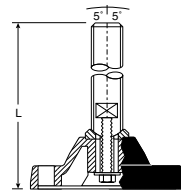
					
<input type="checkbox"/> VG-533	<input type="checkbox"/> VG-537	<input type="checkbox"/> VG-501	<input type="checkbox"/> VG-505	<input type="checkbox"/> VG-511	<input type="checkbox"/> VG-518
		<input type="checkbox"/> VG-501-T		<input type="checkbox"/> VG-511-T	
					
<input type="checkbox"/> VG-513	<input type="checkbox"/> VG-525	<input type="checkbox"/> VG-517-K	<input type="checkbox"/> VG-520	<input type="checkbox"/> VG-520-K	<input type="checkbox"/> VG-520-T

Select Modifications:

- BASE MATERIAL:** Reinforced polyamide Reinforced polypropylene
- BASE CONFIGURATION:** Standard Solid Urethane filled
- LAG HOLES REQUIRED:** 0 1 2
- VIBRATION PADS REQUIRED:** Yes No
- STEM MATERIAL:** Plated steel 304 stainless steel 316 stainless steel
- STEM REQUIREMENTS:** Overall leveler height (L) _____ Socket style
- Thread diameter _____
- Screwdriver slot (min. 100 pieces ordered)
- Wrench Flat (min. 100 pieces ordered)

OTHER: _____

QUANTITY REQUIRED: This order: _____

Annually: _____

DATE DELIVERY REQUIRED: _____

Machine & Equip.
Components

Adjustable Levelers — Solid Metal Bases

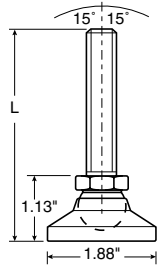

592

Metal Leveler

Equipment and machine support requiring a metal leveler.

Maximum Recommended Static Load: 5000 lbs.

Includes 2:1 safety factor.

Base Material: Zinc plated or stainless steel

Part Number	Stem Thread	Stem Material		"L" Dim
		Zinc	Stainless	
VG-592-01-P12-L3	1/2-13	P		3.13"
VG-592-01-S12-L3	1/2-13		S	3.13"
VG-592-01-P12-L5	1/2-13	P		5.13"
VG-592-01-S12-L5	1/2-13		S	5.13"

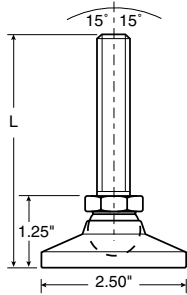

594

Metal Leveler

Equipment and machine support requiring a metal leveler.

Maximum Recommended Static Load: 6000 lbs.

Includes 2:1 safety factor.

Base Material: Zinc plated or stainless steel

Part Number	Stem Thread	Stem Material		"L" Dim
		Zinc	Stainless	
VG-594-01-S58-L3	5/8-11		S	3.25"
VG-594-01-P58-L5	5/8-11	P		5.25"
VG-594-01-S58-L5	5/8-11		S	5.25"
VG-594-01-PM16-L3	M16	P		3.25"
VG-594-01-SM16-L3	M16		S	3.25"

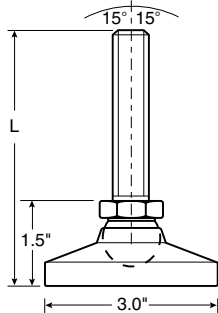

596

Metal Leveler

Equipment and machine support requiring a metal leveler.

Maximum Recommended Static Load: 7200 lbs.

Includes 2:1 safety factor.

Base Material: Zinc plated or stainless steel

Part Number	Stem Thread	Stem Material		"L" Dim
		Zinc	Stainless	
VG-596-01-P34-L3	3/4-10	P		3.5"
VG-596-01-S34-L3	3/4-10		S	3.5"
VG-596-01-P34-L5	3/4-10	P		5.5"
VG-596-01-S34-L5	3/4-10		S	5.5"
VG-596-01-SM20-L3	M20		S	3.5"

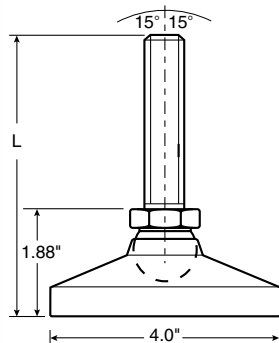

598

Metal Leveler

Equipment and machine support requiring a metal leveler.

Maximum Recommended Static Load: 22000 lbs.

Includes 2:1 safety factor.

Base Material: Zinc plated or stainless steel

Part Number	Stem Thread	Stem Material		"L" Dim
		Zinc	Stainless	
VG-598-01-P100-L6	1-8	P		6.13"
VG-598-01-S100-L6	1-8		S	6.13"
VG-598-01-P100-L10	1-8	P		9.88"
VG-598-01-S100-L10	1-8		S	9.88"

Machine & Equip. Components



Adjustable Levelers — Solid Metal Bases

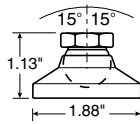

592B

Socket Style

Equipment and machine support requiring a metal leveler.

Max. Rec. Static Load: 5000 lbs.
Includes 2:1 safety factor.

Base Material: Zinc plated or stainless steel

Part Number	Stem Thread	Stem Material	
		Zinc	Stainless
VG-592B-01-P12	1/2-13	P	
VG-592B-01-S12	1/2-13		S

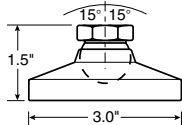

596B

Socket Style

Equipment and machine support requiring a metal leveler.

Max. Rec. Static Load: 7200 lbs.
Includes 2:1 safety factor.

VG-596B-01-P34	3/4-10	P	
VG-596B-01-S34	3/4-10		S
VG-596B-01-PM20	M20	P	
VG-596B-01-SM20	M20		S

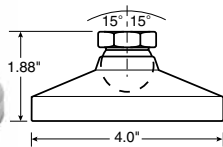

598B

Socket Style

Equipment and machine support requiring a metal leveler.

Max. Rec. Static Load: 22000 lbs.
Includes 2:1 safety factor.

VG-598B-01-P100	1-8	P	
VG-598B-01-S100	1-8		S

Machine & Equip. Components

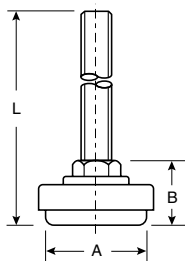

580-NY

Adjustable Glides (Nylon Base)

Light duty leveling.

Maximum Recommended Static Load: 100 lbs.
Includes 2:1 safety factor.

Base Material: Nylon base with zinc or black plated steel finish.
Rockwell rating of base: R105 to R118 steel finish.

Part Number	Stem Thread	Steel Finish		
		Zinc	Black	A B L
VG-580-NY-P516-L2	5/16-18	P		1.0" 0.63" 2.13"

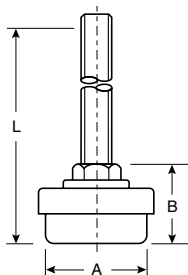

580-NE

Adjustable Glides (Neoprene Base)

Light duty leveling.

Maximum Recommended Static Load: 300 lbs.
(5/16-18 thread: 100 lbs.)
Includes 2:1 safety factor.

Base Material: Neoprene base with zinc or black plated steel finish.
Shore rating of base: 70 to 80

Part Number	Stem Thread	Steel Finish		
		Zinc	Black	A B L
VG-580-NE-P516-L2	5/16-18	P		1.0" 0.81" 3.98"
VG-580-NE-P38-L4	3/8-16	P		1.50" 0.98" 3.98"
VG-580-NE-B38-L4	3/8-16		B	1.50" 0.98" 3.98"
VG-580-NE-P12-L3	1/2-13	P		1.50" 1.06" 3.06"
VG-580-NE-B12-L3	1/2-13		B	1.50" 1.06" 3.06"



307

Post Cap

Holds support legs made of 1-1/2 pipe or 2 inch OD tubing. Adapts to a variety of mounting configurations. Stainless steel tightening hardware included.

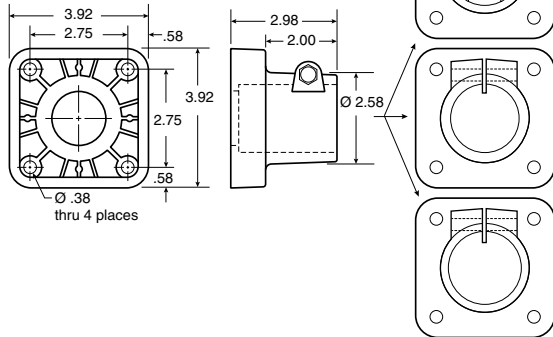

Accepts
1-1/2"
sq. tube

Accepts
1-1/2" pipe

Accepts
2" OD tube



Material: Reinforced polyamide with stainless steel fasteners.

Part Number	Pipe Size	Tube Size
VG-307-1.50	1-1/2	-
VG-307-T2.0	-	2 (OD)
VG-307SQ-T1.50	-	1-1/2 SQ.

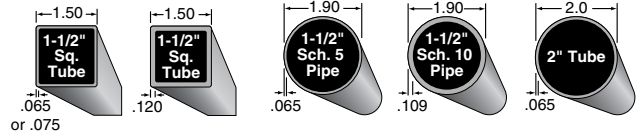

See page 342-343 for threaded tube ends.

308

Post Cap

Holds support legs made of pipe or tube. Adapts to a variety of mounting configurations. Stainless steel tightening hardware included.

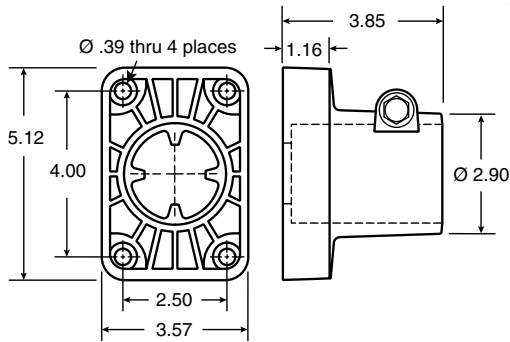

Material: Reinforced polyamide with stainless steel fasteners.

Part Number	Pipe Size	Tube Size
VG-308-1.50	1-1/2	-
VG-308-T2.0	-	2 (OD)
VG-308-2.00	2	-

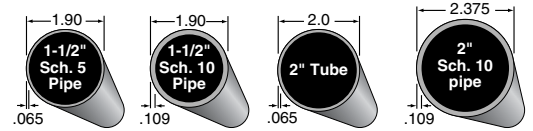

See page 342-343 for threaded tube ends.

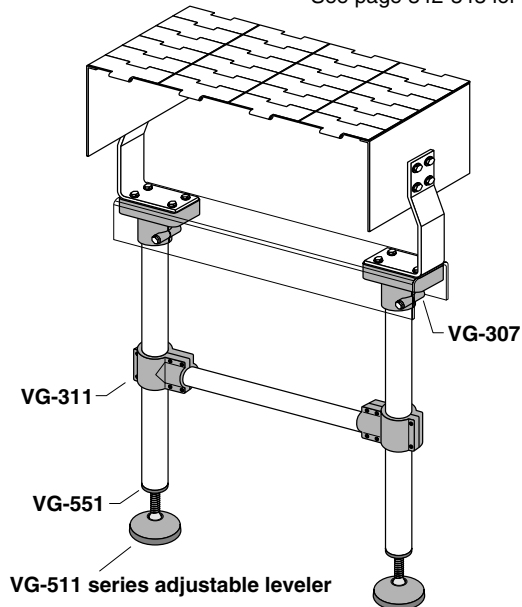
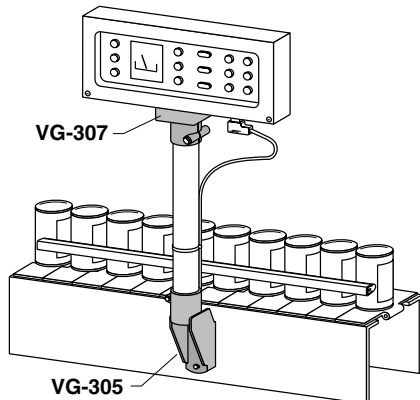

Machine & Equip.
Components

Post Caps and Leg Ties



305

Side Mount Post Cap

Holds support legs made of 1-1/2 inch pipe, 1-1/2 square tubing, or 2 inch OD tubing.

Max. Recommended Static Load: 4400 lbs.
Includes 2:1 safety factor.

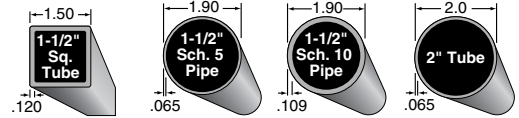
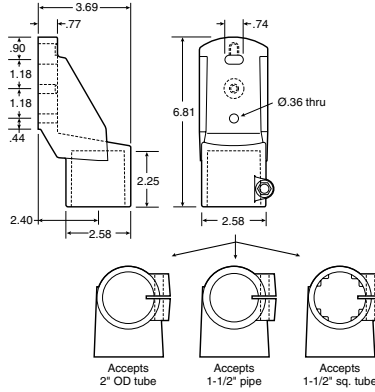

See page 342-343 for threaded tube ends.

Material: Reinforced polyamide with stainless steel fasteners.

Part Number	Pipe Size	Tube Size
VG-305-1.50	1-1/2	-
VG-305-T2.0	-	2 (OD)
VG-305SQ-T1.50	-	1-1/2 SQ.

147

Side Mounting Top Bracket

Holds support legs made of 2 inch OD tubing.

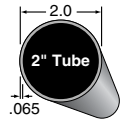
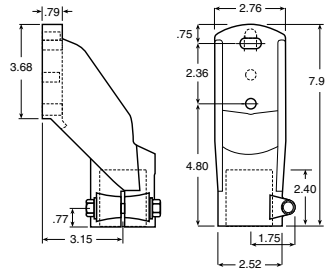

See page 342-343 for threaded tube ends.

Material: Reinforced polyamide with stainless steel fasteners.

Part Number	Pipe Size	Tube Size
14744N	2	-

14053

Side Mounting Bracket

For supporting side guides.

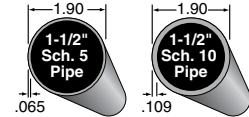
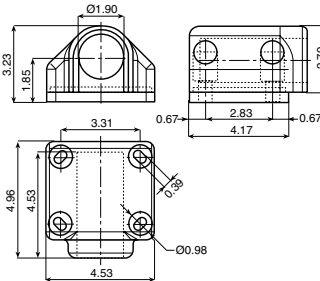

Material: Reinforced polyamide.

Part Number	Pipe Size
14053	1-1/2

C115

Connector for Square Tubing

Hardware included.

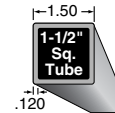
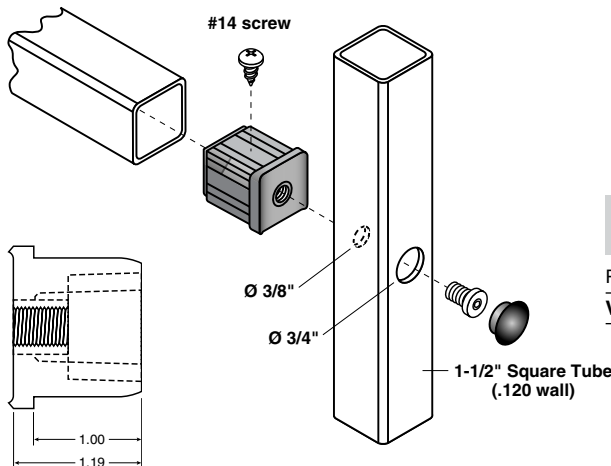
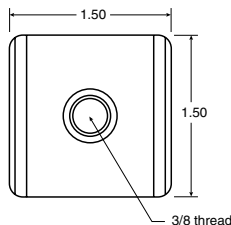

Material: Reinforced polyamide with stainless steel fasteners.

Part Number	Fits Tube Size
VG-C115	1-1/2 SQ.



311

Tee Leg Tie

Ties conveyor support legs together at 90° for reinforcement.

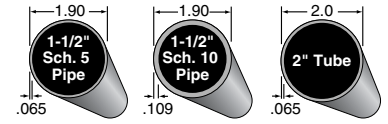
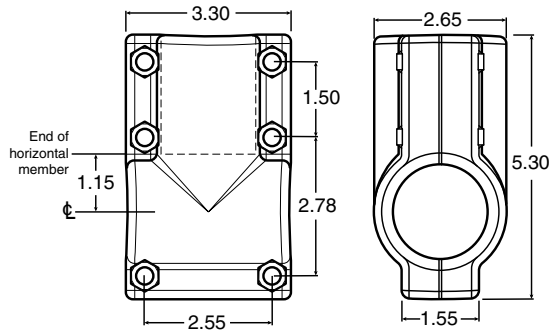
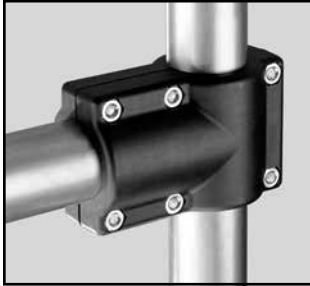

See page 342-343 for threaded tube ends.

Material: Reinforced polyamide with stainless steel fasteners.

Part Number	Vertical Member	Horizontal Member
14729	1-1/4" pipe	1-1/4" pipe
14734	1-1/2" pipe	1-1/4" pipe
VG-311-1515-M	1-1/2" pipe	1-1/2" pipe
VG-311-T2020	2" tube	2" tube

13827

Connecting Joints

Holds support legs made from round tubing. Hardware not included.

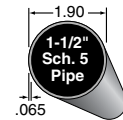
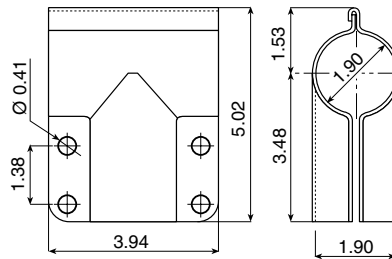

Material: Stainless steel.

Part Number	Vertical Member	Horizontal Member
13827	1-1/2" pipe	1-1/2" pipe

13828

Connecting Joints

Holds support legs made from round tubing. Hardware not included.

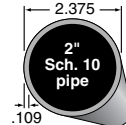
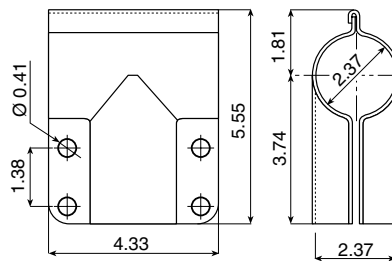

Material: Stainless steel.

Part Number	Vertical Member	Horizontal Member
13828	2" pipe	2" pipe

Machine & Equip.
Components

Bipod Bases

350/150 series

Bipod Base

Leg base for machinery support. Threaded leg inserts for adjustable levelers and stainless steel tightening hardware included.

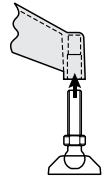
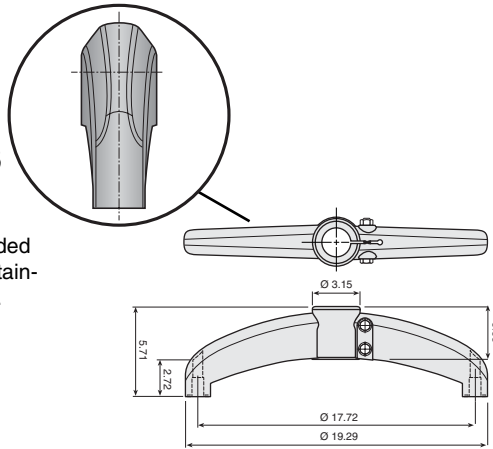

Part Number	Type	Thread
35058	1-1/4" pipe	5/8
35060	1-1/2" pipe	5/8
35062	2" tube	5/8
35064	2" pipe	5/8
15058	1-1/4" pipe	M16
15060	1-1/2" pipe	M16
15062	2" tube	M16
15064	2" pipe	M16

350/150 series

Bipod Base & Cross-Tie

Leg base for machinery support plus 1-1/4 or 1-1/2 pipe cross-tie arm openings for increased lateral stability. Threaded leg inserts for adjustable levelers and stainless steel tightening hardware included.

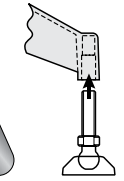
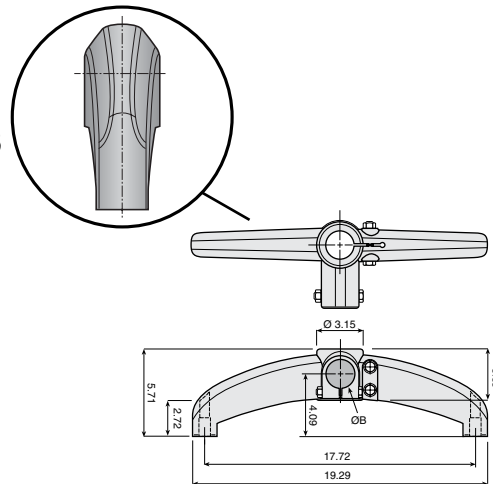

Part Number	Type	Horiz. Tie (B)	Thread
35066	1-1/4" pipe	1-1/4" pipe	5/8
35068	1-1/2" pipe	1-1/4" pipe	5/8
35070	2" tube	1-1/4" pipe	5/8
35072	2" pipe	1-1/4" pipe	5/8
35074	1-1/2" pipe	1-1/2" pipe	5/8
35076	2" tube	1-1/2" pipe	5/8
35078	2" pipe	1-1/2" pipe	5/8
15068	1-1/2" pipe	1-1/4" pipe	M16
15070	2" tube	1-1/4" pipe	M16
15072	2" pipe	1-1/4" pipe	M16
15074	1-1/2" pipe	1-1/2" pipe	M16
15076	2" tube	1-1/2" pipe	M16

Machine & Equip.
Components



Tripod and Bipod Bases

Bases can be used with the following:

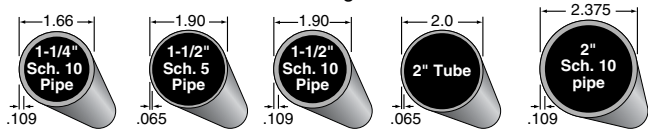

Material: Reinforced polyamide with stainless steel fasteners and threaded brass inserts.

350/150 series

Tripod Base

Leg base for machinery support. Threaded leg inserts for adjustable levelers and stainless steel tightening hardware included.

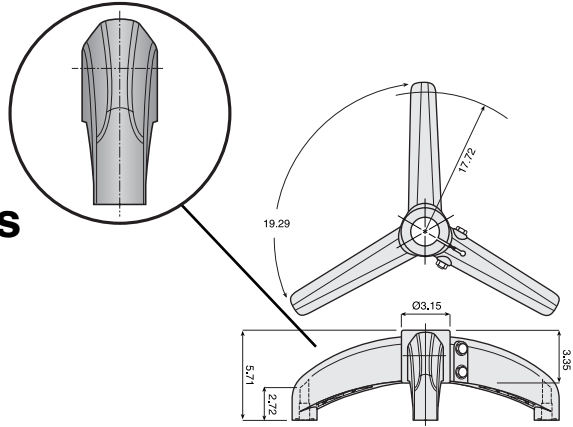

Part Number	Type	Thread
35082	1-1/4" pipe	5/8
35084	1-1/2" pipe	5/8
35086	2" tube	5/8
35088	2" pipe	5/8
15084	1-1/2" pipe	M16
15086	2" tube	M16
15088	2" pipe	M16

350/150 series

Bipod Base & Cross-Tie

Leg base for machinery support plus 1-1/4 or 1-1/2 pipe cross-tie arm openings for increased lateral stability. Threaded leg inserts for adjustable levelers and stainless steel tightening hardware included.

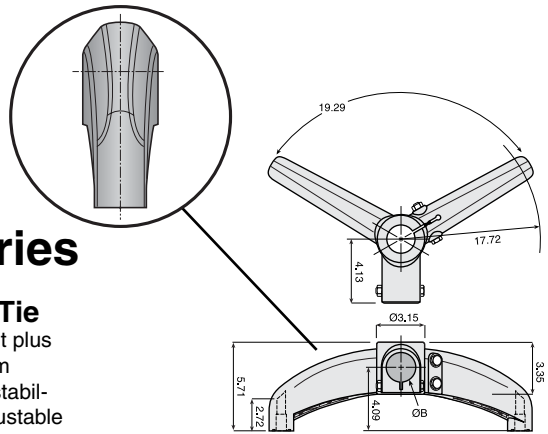

Part Number	Type	Horiz. Tie (B)	Thread
35094	2" tube	1-1/4" pipe	5/8
35098	1-1/2" pipe	1-1/2" pipe	5/8
35100	2" tube	1-1/2" pipe	5/8
35102	2" pipe	1-1/2" pipe	5/8
15090	1-1/4" pipe	1-1/4" pipe	M16
15092	1-1/2" pipe	1-1/4" pipe	M16
15094	2" tube	1-1/4" pipe	M16
15096	2" pipe	1-1/4" pipe	M16
15100	2" tube	1-1/2" pipe	M16
15102	2" pipe	1-1/2" pipe	M16

15500

Split Bipod Base

Leg base for machinery support. Threaded leg inserts for adjustable levelers or direct floor mounting and stainless steel tightening hardware included.

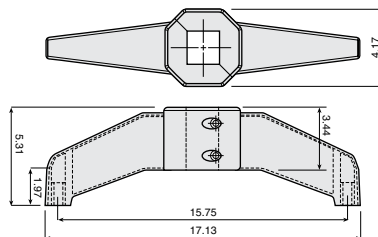

Part Number	Type	Thread
15500	2.0" 50 mm	M16

Machine & Equip. Components

Sanitary Legs



452

Sanitary Leg Weld Cap

Attaches to VG-450 Sanitary Leg and can be welded to conveyor frame. Set screw holds leg in place.

Material: Stainless steel

Part Number

VG-452

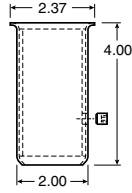

450

Sanitary Leg

Stainless steel leg base for conveyor support. Has about 1-1/4 inch of leveling adjustment per leg.

Material: Stainless steel

Part Number

VG-450

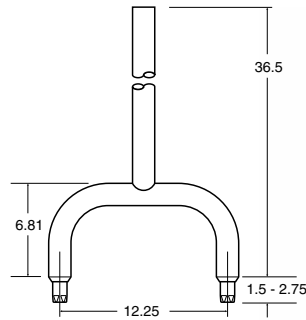

Recommended Maximum Load

Support member: 2 inch schedule 40 pipe.
Maximum bolt torque: 300 ft. lbs.

VG-402: 1900 lbs.
VG-410: 1700 lbs.

Support member: 2 inch tube (thin wall).
Maximum bolt torque: 150 ft. lbs.

VG-402: 1400 lbs.
VG-410: 1100 lbs.

Support Member	Substructure Compatibility								
1-1/4" pipe	VG-402	VG-404	VG-410						
1-1/2" pipe	VG-402	VG-403	VG-404	VG-410	VG-305	VG-307	VG-308	VG-311	
2" tube	VG-402	VG-403	VG-404	VG-410	VG-305	VG-307	VG-308	VG-311	
2" pipe	VG-402	VG-403	VG-404	VG-410				VG-308	

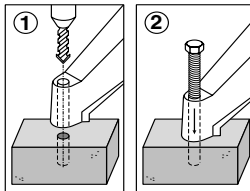

Direct Floor Anchoring

Structural reinforcing in the design allows the base to withstand loads required for floor anchoring. Drill with 1/2 bit as shown.

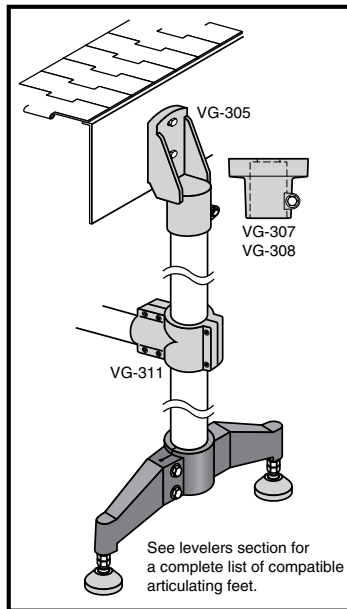
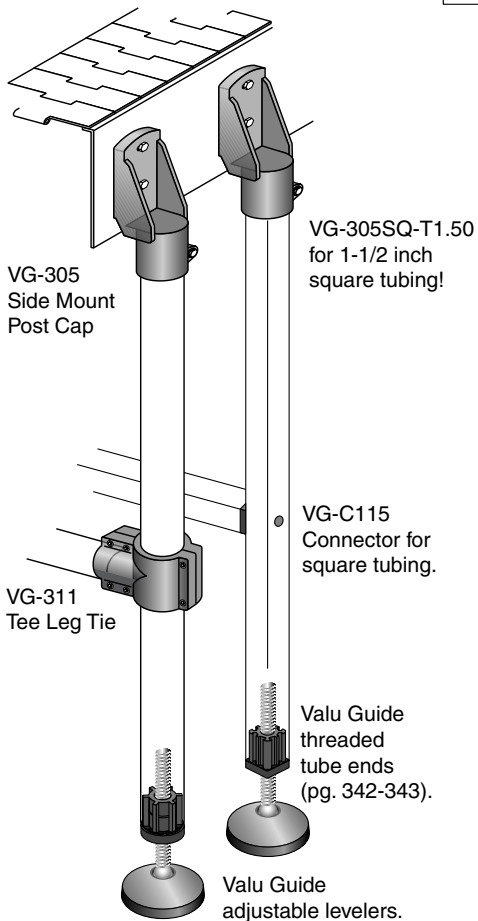

See levelers section for a complete list of compatible articulating feet.

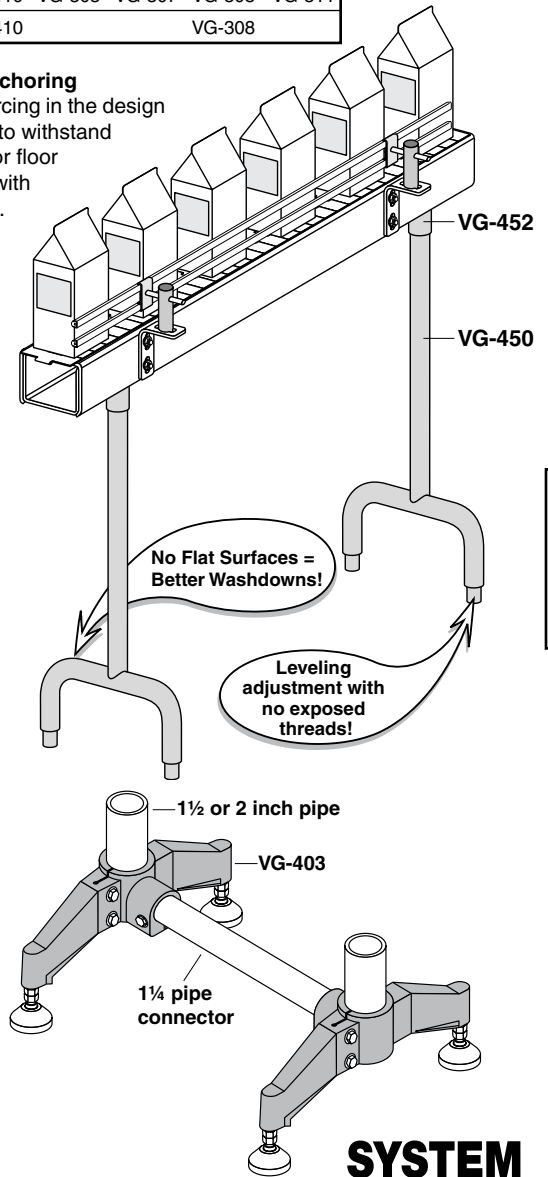

SYSTEM PLAST™



Adjustable Ratchet Handles - Male



RH

Male Ratchet Handles

For use in areas where frequent adjusting is required, where handle movement is restricted, or where adjustability without tools is desired. Reinforced polyamide handles are strong, sanitary, and corrosion resistant. Choose from multiple sizes, colors, and materials.

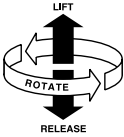
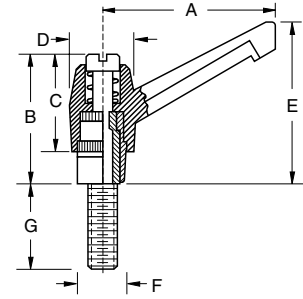
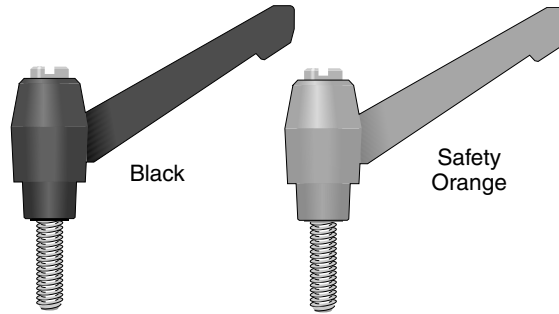

	Black	Orange	Material		Thread	G	Inches (Millimeters)					
			Black Oxide Coated Steel	Stainless Steel			A	B	C	D	E	F
 RH-10	RH-10-BK-MP1032-15	-	•		10-32	0.59	1.63 (41)	1.21 (31)	0.91 (23)	0.63 (16)	1.51 (38)	0.42 (11)
	RH-10-BK-MS1032-15	-		•	10-32	0.59						
	RH-10-BK-MP1032-20	-	•		10-32	0.79						
	RH-10-BK-MS1024-15	RH-10-OR-MS1024-15		•	10-24	0.59						
	RH-10-BK-MP1024-20	-	•		10-24	0.79						
	RH-10-BK-MS1024-20	RH-10-OR-MS1024-20		•	10-24	0.79						
	RH-10-BK-MP1420-20	RH-10-OR-MP1420-20	•		1/4-20	0.79						
	RH-10-BK-MS1420-20	RH-10-OR-MS1420-20		•	1/4-20	0.79						
	RH-10-BK-MP1420-25	RH-10-OR-MP1420-25	•		1/4-20	0.98						
	RH-10-BK-MS1420-25	RH-10-OR-MS1420-25		•	1/4-20	0.98						
	RH-10-BK-MP1420-30	RH-10-OR-MP1420-30	•		1/4-20	1.18						
RH-10-BK-MS1420-30	RH-10-OR-MS1420-30		•	1/4-20	1.18							
 RH-20	RH-20-BK-MP51618-15	RH-20-OR-MP51618-15	•		5/16-18	0.59	2.16 (55)	1.39 (35)	1.02 (26)	0.80 (20)	1.94 (49)	0.53 (13)
	RH-20-BK-MS51618-15	RH-20-OR-MS51618-15		•	5/16-18	0.59						
	RH-20-BK-MP51618-20	RH-20-OR-MP51618-20	•		5/16-18	0.79						
	RH-20-BK-MS51618-20	RH-20-OR-MS51618-20		•	5/16-18	0.79						
	RH-20-BK-MP51618-30	RH-20-OR-MP51618-30	•		5/16-18	1.18						
	RH-20-BK-MS51618-30	RH-20-OR-MS51618-30		•	5/16-18	1.18						
	RH-20-BK-MP51618-40	RH-20-OR-MP51618-40	•		5/16-18	1.57						
	RH-20-BK-MS51618-40	RH-20-OR-MS51618-40		•	5/16-18	1.57						
	RH-20-BK-MP51618-50	RH-20-OR-MP51618-50	•		5/16-18	1.97						
	RH-20-BK-MS51618-50	RH-20-OR-MS51618-50		•	5/16-18	1.97						
 RH-30	RH-30-BK-MP3816-20	RH-30-OR-MP3816-20	•		3/8-16	0.79	3.13 (80)	1.82 (46)	1.36 (35)	1.06 (27)	2.58 (66)	0.72 (18)
	RH-30-BK-MS3816-20	RH-30-OR-MS3816-20		•	3/8-16	0.79						
	RH-30-BK-MP3816-30	RH-30-OR-MP3816-30	•		3/8-16	1.18						
	RH-30-BK-MS3816-30	RH-30-OR-MS3816-30		•	3/8-16	1.18						
	RH-30-BK-MP3816-40	RH-30-OR-MP3816-40	•		3/8-16	1.57						
	RH-30-BK-MS3816-40	RH-30-OR-MS3816-40		•	3/8-16	1.57						
	RH-30-BK-MP3816-50	RH-30-OR-MP3816-50	•		3/8-16	1.97						
	RH-30-BK-MS3816-50	RH-30-OR-MS3816-50		•	3/8-16	1.97						
	RH-30-BK-MP1213-30	RH-30-OR-MP1213-30	•		1/2-13	1.18						
	RH-30-BK-MS1213-40	RH-30-OR-MS1213-40		•	1/2-13	1.57						
	RH-30-BK-MS1213-40	RH-30-OR-MS1213-40		•	1/2-13	1.57						
	RH-30-BK-MS1213-50	-		•	1/2-13	1.97						
	RH-30-BK-MP1213-60	RH-30-OR-MP1213-60	•		1/2-13	2.36						
	RH-30-BK-MS1213-60	RH-30-OR-MS1213-60		•	1/2-13	2.36						

Machine & Equip. Components

Adjustable Ratchet Handles - Female



RH

Female Ratchet Handles

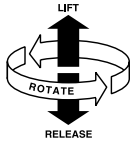
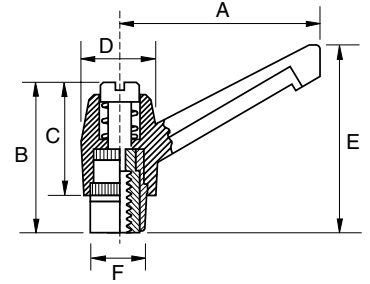
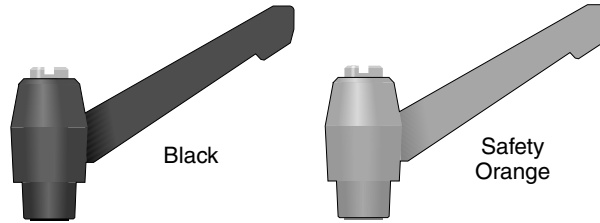

	Black	Orange	Material		Thread	Inches (Millimeters)					
			Black Oxide Coated Steel	Stainless Steel		A	B	C	D	E	F
RH-10	RH-10-BK-FP1032	RH-10-OR-FP1032	•		10-32	1.63 (41)	1.21 (31)	0.91 (23)	0.63 (16)	1.51 (38)	0.42 (11)
	RH-10-BK-FP1024	RH-10-OR-FP1024	•		10-24						
	RH-10-BK-FS1024	RH-10-OR-FS1024		•	10-24						
	RH-10-BK-FP1420	RH-10-OR-FP1420	•		1/4-20						
	RH-10-BK-FS1420	RH-10-OR-FS1420		•	1/4-20						
RH-20	RH-20-BK-FP1420	RH-20-OR-FP1420	•		1/4-20	2.16 (55)	1.39 (35)	1.02 (26)	0.80 (20)	1.94 (49)	0.53 (13)
	RH-20-BK-FS1420	RH-20-OR-FS1420		•	1/4-20						
	RH-20-BK-FP51618	RH-20-OR-FP51618	•		5/16-18						
	RH-20-BK-FS51618	RH-20-OR-FS51618		•	5/16-18						
RH-30	RH-30-BK-FP51618	RH-30-OR-FP51618	•		5/16-18	3.13 (80)	1.82 (46)	1.36 (35)	1.06 (27)	2.58 (66)	0.72 (18)
	RH-30-BK-FS51618	RH-30-OR-FS51618		•	5/16-18						
	RH-30-BK-FP3816	RH-30-OR-FP3816	•		3/8-16						
	RH-30-BK-FS3816	RH-30-OR-FS3816		•	3/8-16						
	RH-30-BK-FP1213	RH-30-OR-FP1213	•		1/2-13						
	RH-30-BK-FS1213	RH-30-OR-FS1213		•	1/2-13						

*Note: Threaded inserts for female handles are made of nickel plated brass to avoid galling (surface wear) or seizing.

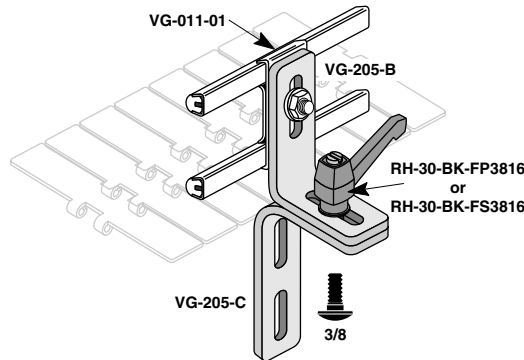

Recommended Maximum Torque:

- RH-10** 5 N•m or 45 in/lbs
- RH-20** 11.3 N•m or 100 in/lbs
- RH-30** 28.3 N•m or 250 in/lbs
- RH-40** 56.5 N•m or 500 in/lbs

ORDERING INFORMATION

RH-10-BK-MP1032-15

- Stud length (male only): 15 mm or .59 in., 20 mm or .79 in., 25 mm or .98 in., 30 mm or 1.18 in., 40 mm or 1.57 in., 50 mm or 1.97 in., 60 mm or 2.36 in.
- Bolt size in metric or: 1032=10-32, 1024=10-24, 1420=1/4-20, 51618=5/16-18, 3816= 3/8-16, 1213=1/2-13
- Configuration and material: M=male, F=female, P=black oxide coated steel, S=stainless steel
- Color: BK= black, OR=orange
- Ratchet Handle size: 10=small, 20=medium, 30=large, 40=extra large

Machine & Equip. Components



Adjustable Metric Ratchet Handles - Male



RH

Metric Male Ratchet Handles

For use in areas where frequent adjusting is required, where handle movement is restricted, or where adjustability without tools is desired. Reinforced polyamide handles are strong, sanitary, and corrosion resistant. Choose from multiple sizes, colors, and materials.

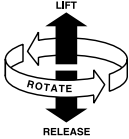
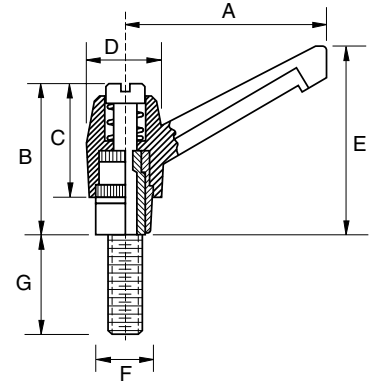
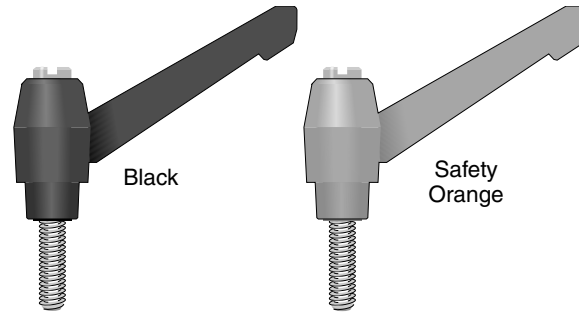

	Black	Orange	Material		Thread	Inches (Millimeters)						
			Black Oxide Coated Steel	Stainless Steel		G	A	B	C	D	E	F
<p>RH-10</p>	RH-10-BK-MPM5-15	-	•		M5 x .08	15	1.63 (41)	1.21 (31)	0.91 (23)	0.63 (16)	1.51 (38)	0.42 (11)
	RH-10-BK-MSM5-15	-		•	M5 x .08	15						
	RH-10-BK-MPM5-20	RH-10-OR-MPM5-20	•		M5 x .08	20						
	RH-10-BK-MSM5-20	RH-10-OR-MSM5-20		•	M5 x .08	20						
	RH-10-BK-MPM5-25	-	•		M5 x .08	25						
	RH-10-BK-MSM5-25	RH-10-OR-MSM5-25		•	M5 x .08	25						
	RH-10-BK-MPM6-15	RH-10-OR-MPM6-15	•		M6 x 1	15						
	RH-10-BK-MSM6-15	RH-10-OR-MSM6-15		•	M6 x 1	15						
	RH-10-BK-MPM6-20	RH-10-OR-MPM6-20	•		M6 x 1	20						
	RH-10-BK-MSM6-20	RH-10-OR-MSM6-20		•	M6 x 1	20						
	RH-10-BK-MPM6-25	RH-10-OR-MPM6-25	•		M6 x 1	25						
	RH-10-BK-MSM6-25	RH-10-OR-MSM6-25		•	M6 x 1	25						
RH-10-BK-MPM6-30	RH-10-OR-MPM6-30	•		M6 x 1	30							
RH-10-BK-MSM6-30	RH-10-OR-MSM6-30		•	M6 x 1	30							
<p>RH-20</p>	RH-20-BK-MPM8-15	-	•		M8 x 1.25	15	2.16 (55)	1.39 (35)	1.02 (26)	0.80 (20)	1.94 (49)	0.53 (13)
	RH-20-BK-MSM8-15	RH-20-OR-MSM8-15		•	M8 x 1.25	15						
	RH-20-BK-MPM8-20	RH-20-OR-MPM8-20	•		M8 x 1.25	20						
	RH-20-BK-MSM8-20	RH-20-OR-MSM8-20		•	M8 x 1.25	20						
	RH-20-BK-MPM8-30	RH-20-OR-MPM8-30	•		M8 x 1.25	30						
	RH-20-BK-MSM8-30	RH-20-OR-MSM8-30		•	M8 x 1.25	30						
	RH-20-BK-MPM8-40	RH-20-OR-MPM8-40	•		M8 x 1.25	40						
	RH-20-BK-MSM8-40	RH-20-OR-MSM8-40		•	M8 x 1.25	40						
	RH-20-BK-MPM8-50	RH-20-OR-MPM8-50	•		M8 x 1.25	50						
	RH-20-BK-MSM8-50	RH-20-OR-MSM8-50		•	M8 x 1.25	50						
<p>RH-30</p>	RH-30-BK-MPM10-20	RH-30-OR-MPM10-20	•		M10 x 1.5	20	3.13 (80)	1.82 (46)	1.36 (35)	1.06 (27)	2.58 (66)	0.72 (18)
	RH-30-BK-MSM10-20	RH-30-OR-MSM10-20		•	M10 x 1.5	20						
	RH-30-BK-MPM10-30	RH-30-OR-MPM10-30	•		M10 x 1.5	30						
	RH-30-BK-MSM10-30	RH-30-OR-MSM10-30		•	M10 x 1.5	30						
	RH-30-BK-MPM10-40	RH-30-OR-MPM10-40	•		M10 x 1.5	40						
	RH-30-BK-MSM10-40	RH-30-OR-MSM10-40		•	M10 x 1.5	40						
	RH-30-BK-MPM10-50	RH-30-OR-MPM10-50	•		M10 x 1.5	50						
	RH-30-BK-MSM10-50	RH-30-OR-MSM10-50		•	M10 x 1.5	50						
	RH-30-BK-MPM12-20	-	•		M12 x 1.75	20						
	RH-30-BK-MPM12-30	-	•		M12 x 1.75	30						
	RH-30-BK-MSM12-30	-		•	M12 x 1.75	30						
	RH-30-BK-MPM12-40	-	•		M12 x 1.75	40						
	RH-30-BK-MSM12-40	-		•	M12 x 1.75	40						
	RH-30-BK-MPM12-50	-	•		M12 x 1.75	50						
	RH-30-BK-MSM12-50	-		•	M12 x 1.75	50						
	RH-30-BK-MPM12-60	-	•		M12 x 1.75	60						

Machine & Equip. Components



RH

Metric Female Ratchet Handles

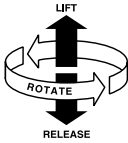
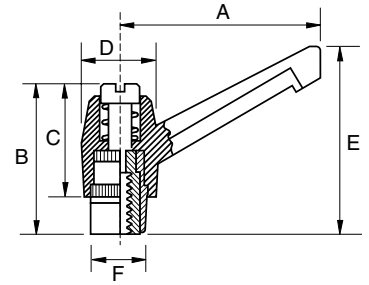
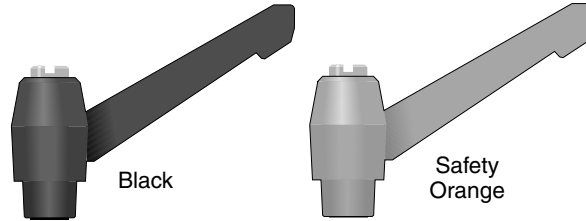

	Black	Orange	Black Oxide Coated Steel*	Stainless Steel*	Thread	Inches (Millimeters)					
						A	B	C	D	E	F
RH-10	RH-10-BK-FSM5	-		•	M5 x .08						
	RH-10-BK-FPM6	RH-10-OR-FPM6	•		M6 x 1	1.63 (41)	1.21 (31)	0.91 (23)	0.63 (16)	1.51 (38)	0.42 (11)
	RH-10-BK-FSM6	RH-10-OR-FSM6		•	M6 x 1						
RH-20	RH-20-BK-FPM6	-	•		M6 x 1						
	RH-20-BK-FSM6	RH-20-OR-FSM6		•	M6 x 1	2.16 (55)	1.39 (35)	1.02 (26)	0.80 (20)	1.94 (49)	0.53 (13)
	RH-20-BK-FPM8	RH-20-OR-FPM8	•		M8 x 1.25						
	RH-20-BK-FSM8	RH-20-OR-FSM8		•	M8 x 1.25						
RH-30	RH-30-BK-FPM8	-	•		M8 x 1.25						
	RH-30-BK-FSM8	-		•	M8 x 1.25						
	RH-30-BK-FPM10	RH-30-OR-FPM10	•		M10 x 1.5	3.13 (80)	1.82 (46)	1.36 (35)	1.06 (27)	2.58 (66)	0.72 (18)
	RH-30-BK-FSM10	RH-30-OR-FSM10		•	M10 x 1.5						
	RH-30-BK-FPM12	-	•		M12 x 1.75						
	RH-30-BK-FSM12	-		•	M12 x 1.75						

*Note: Threaded inserts for female handles are made of nickel plated brass to avoid galling (surface wear) or seizing.

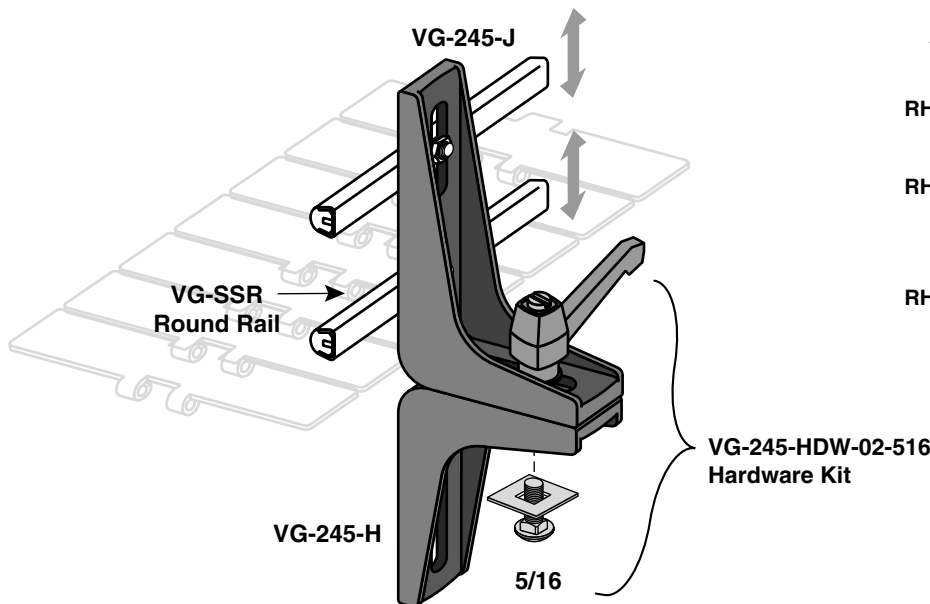

Recommended Maximum Torque:

- RH-10** 5 N•m or 45 in/lbs
- RH-20** 11.3 N•m or 100 in/lbs
- RH-30** 28.3 N•m or 250 in/lbs

Machine & Equip. Components



Handles

631

Standard Duty Handle

Sleek, medium duty handle used for doors, cabinets and other applications.

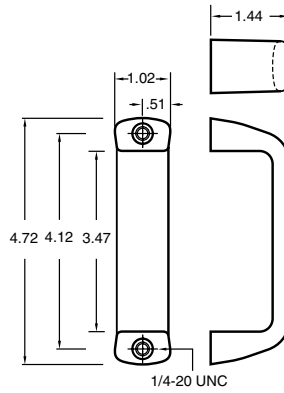
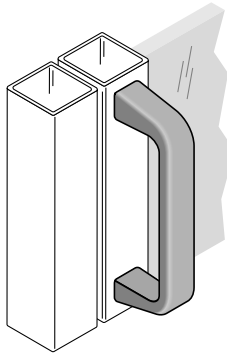

Materials: Reinforced gray or black polyamide with female threaded brass insert.

Part Number	Color	Thread
VG-631-14	Black	1/4-20
VG-631-14-GR	Gray	1/4-20

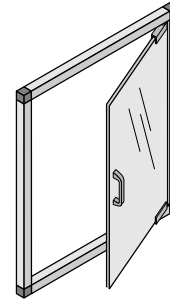

632

Heavy Duty Handle

Corrosion resistant design offers exceptional durability for doors, cabinets, clean-out panels, lift up covers and applications requiring a stronger handle.

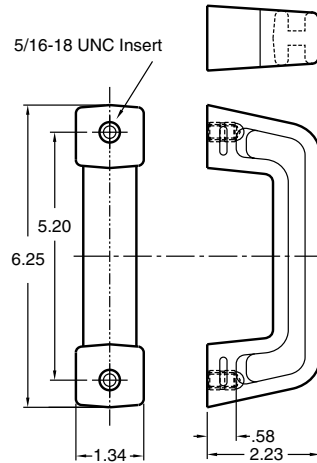
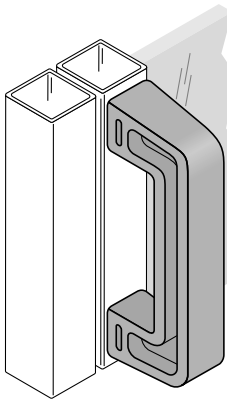

Materials: Reinforced black polyamide with female threaded brass insert.

Part Number	Color	Thread
VG-632-516	Black	5/16-18

Machine & Equip.
Components

630

Safety Handle

Closed designed handle allows easy opening without pinched fingers and scraped knuckles when handles are mounted side by side on adjacent doors. Fasteners and tube hole caps included.

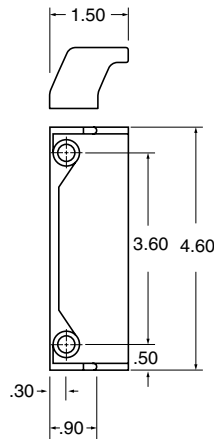
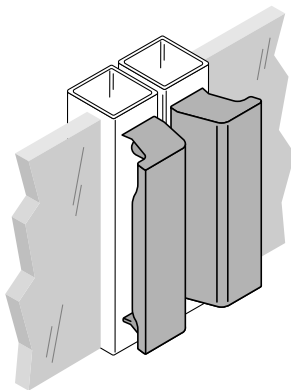

Materials: Reinforced black polyamide with 304 stainless steel screws and polyamide caps included.

Part Number	Color	Thread
VG-630-BK	Black	M6

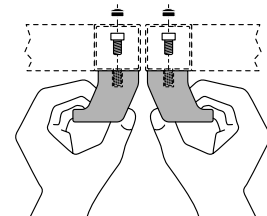



633

Standard Duty Hinge

Attractive, corrosion resistant design offers exceptional durability for doors, cabinets, clean-out panels and lift up covers. Fastening holes are pre-drilled, each ribbed for additional strength.

Fasteners not included.

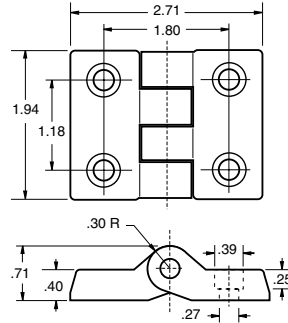
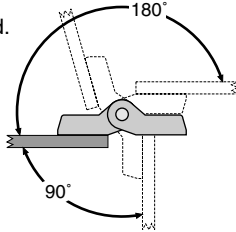

Materials: Reinforced gray or black polyamide with stainless steel pin.

Part Number	Color
VG-633	Black
VG-633-GR	Gray

Two Hinge Load Capacity

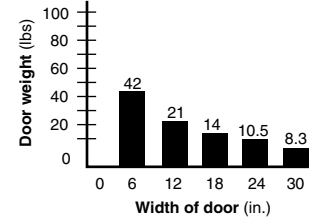

634

Heavy Duty Hinge

Corrosion resistant design offers exceptional durability with a higher load capacity. Fastening holes are predrilled on both the full surface or offset styles, each ribbed for additional strength.

Fasteners not included.

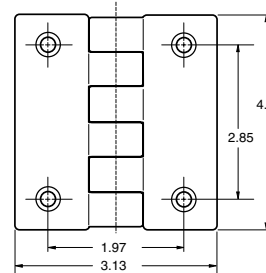

Materials: Reinforced black polyamide with stainless steel pin.

Part Number	Color	Fastener(in.)
VG-634-AA	Black	1/4
VG-634-AB	Black	1/4
VG-634-BB	Black	1/4
VG-634-CC	Black	5/16
VG-634-CD	Black	5/16
VG-634-DD	Black	5/16

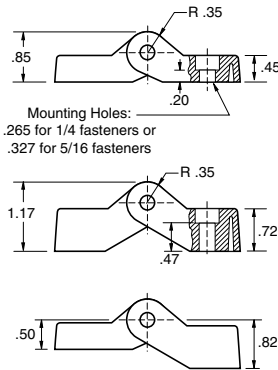
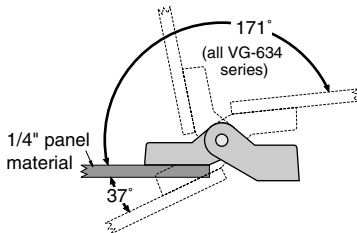

VG-634-AA (1/4 mount)
VG-634-CC (5/16 mount)

VG-634-BB (1/4 mount)
VG-634-DD (5/16 mount)

VG-634-AB (1/4 mount)
VG-634-CD (5/16 mount)

Two Hinge Load Capacity

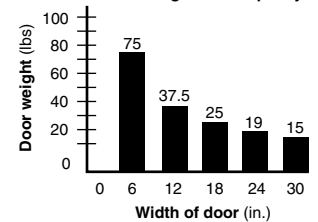

635

Standard Duty Hinge

Attractive, corrosion resistant design offers exceptional durability for swinging doors and panels. Designed for 1/4 inch gap between door and frame. Fasteners not included.

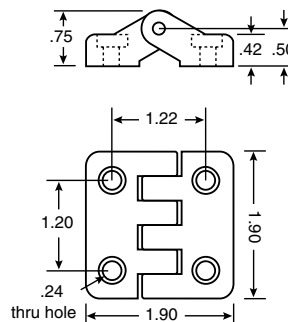
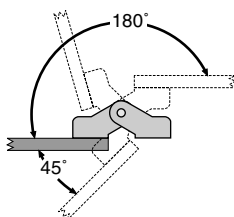

Materials: Reinforced gray or black polyamide.

Part Number	Color
VG-635-BK	Black
VG-635-GR	Gray

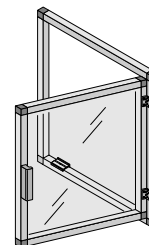

Machine & Equip. Components



Hinges and Typical Substructure Applications

400 series

Standard Duty Hinge

Attractive, corrosion resistant design offers exceptional durability for doors, cabinets, clean-out panels and lift up covers. Fasteners not included.



Materials: Reinforced black polyamide with threaded brass insert.

Part Number	Type	A	B	C	D	E	F	G	H
40018	3	1.54	1.56	1.00	1.00	0.35	0.37	0.55	0.17
40009	1	1.93	1.93	1.22	1.18	0.43	0.51	0.67	M6
40031	4	1.93	1.93	1.22	1.18	0.43	0.51	0.67	0.21

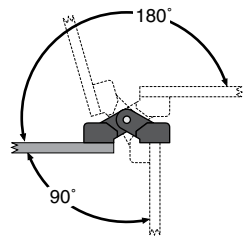
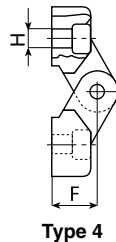
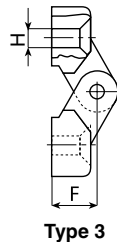
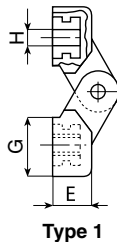
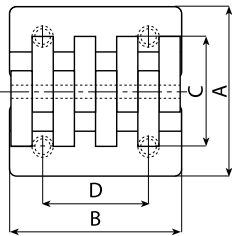

Machine & Equip. Components

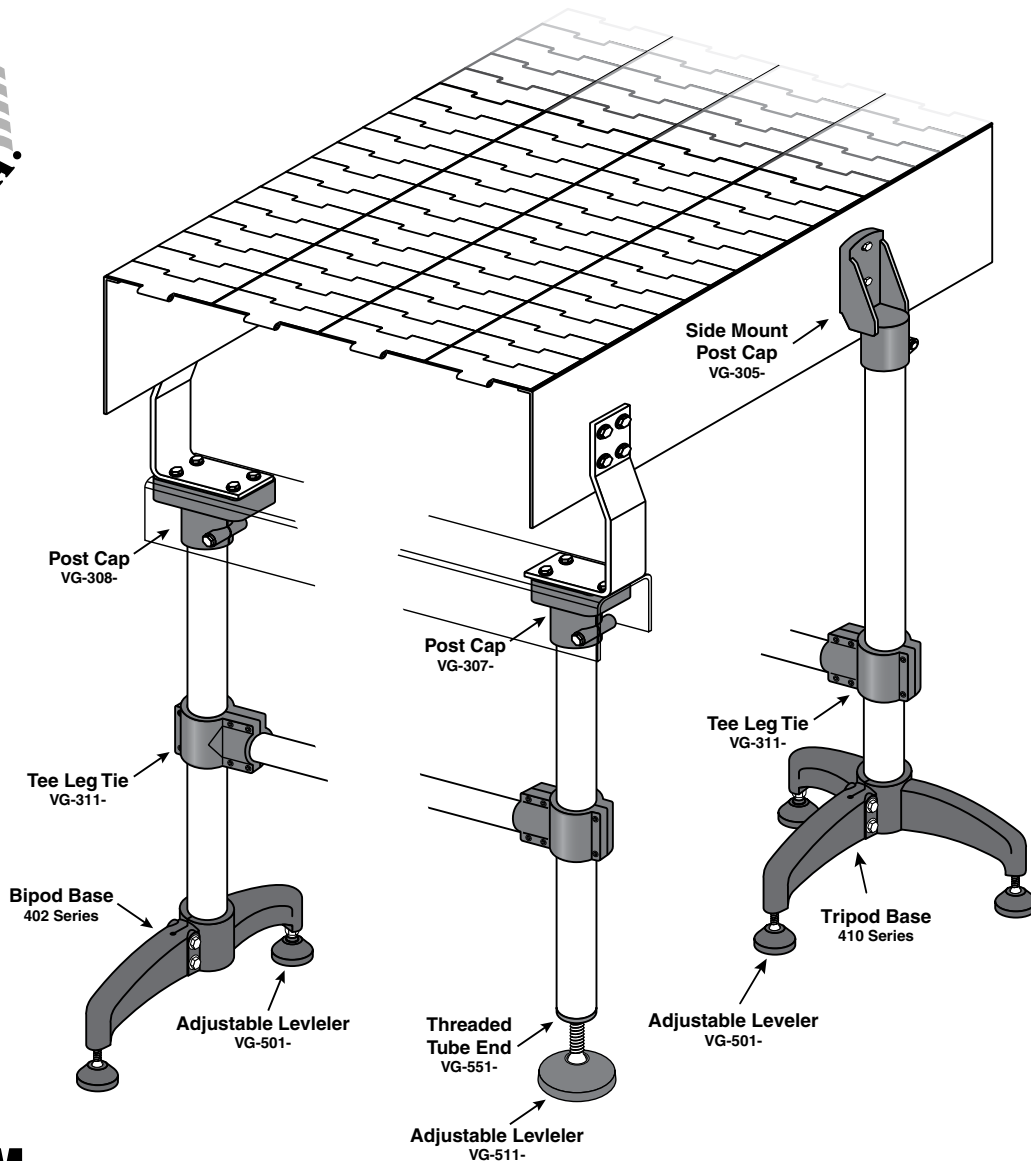

SYSTEM PLAST™

©2015 Regal-Beloit Corporation, All Rights Reserved.

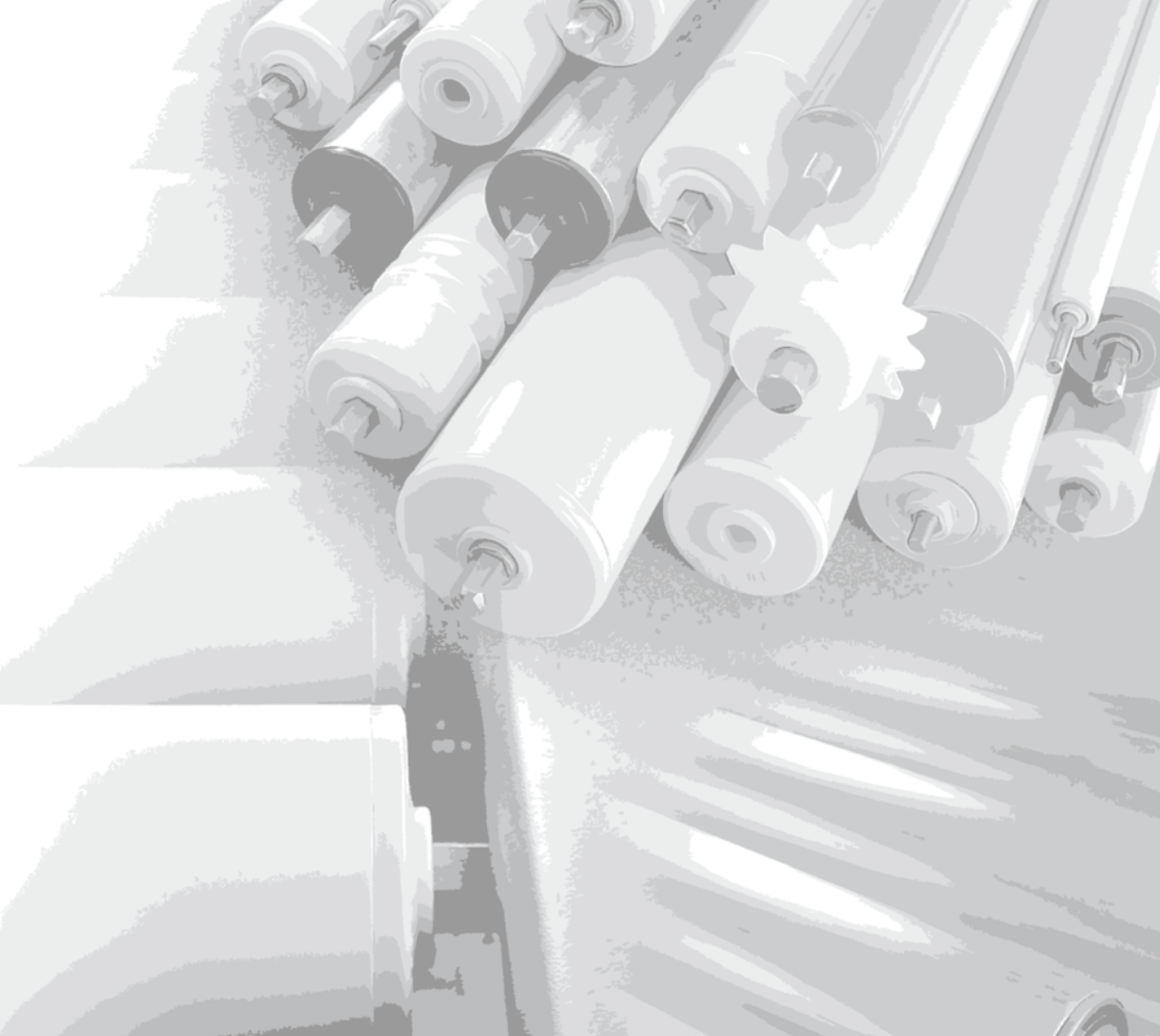

ROLLER PRODUCTS

Section 9

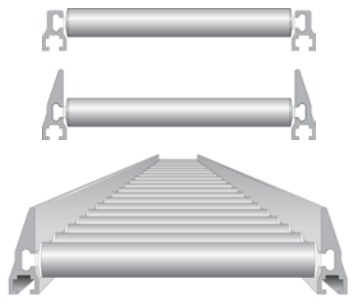

Roll-Tech Page 384



Return Rollers Page 386



Standard Roller Selection..... Page 392



Custom Roller Selection..... Page 396

- Sleeve & Ball Bearing Rollers
- Belt Driven Rollers
- Sprocket Rollers
- Blind Bore Rollers
- PVC Rollers
- Tapered Rollers
- Thru Bore Rollers
- Sealed End Rollers
- Metal Rollers

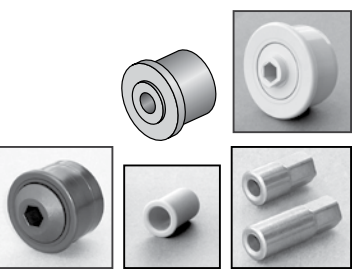
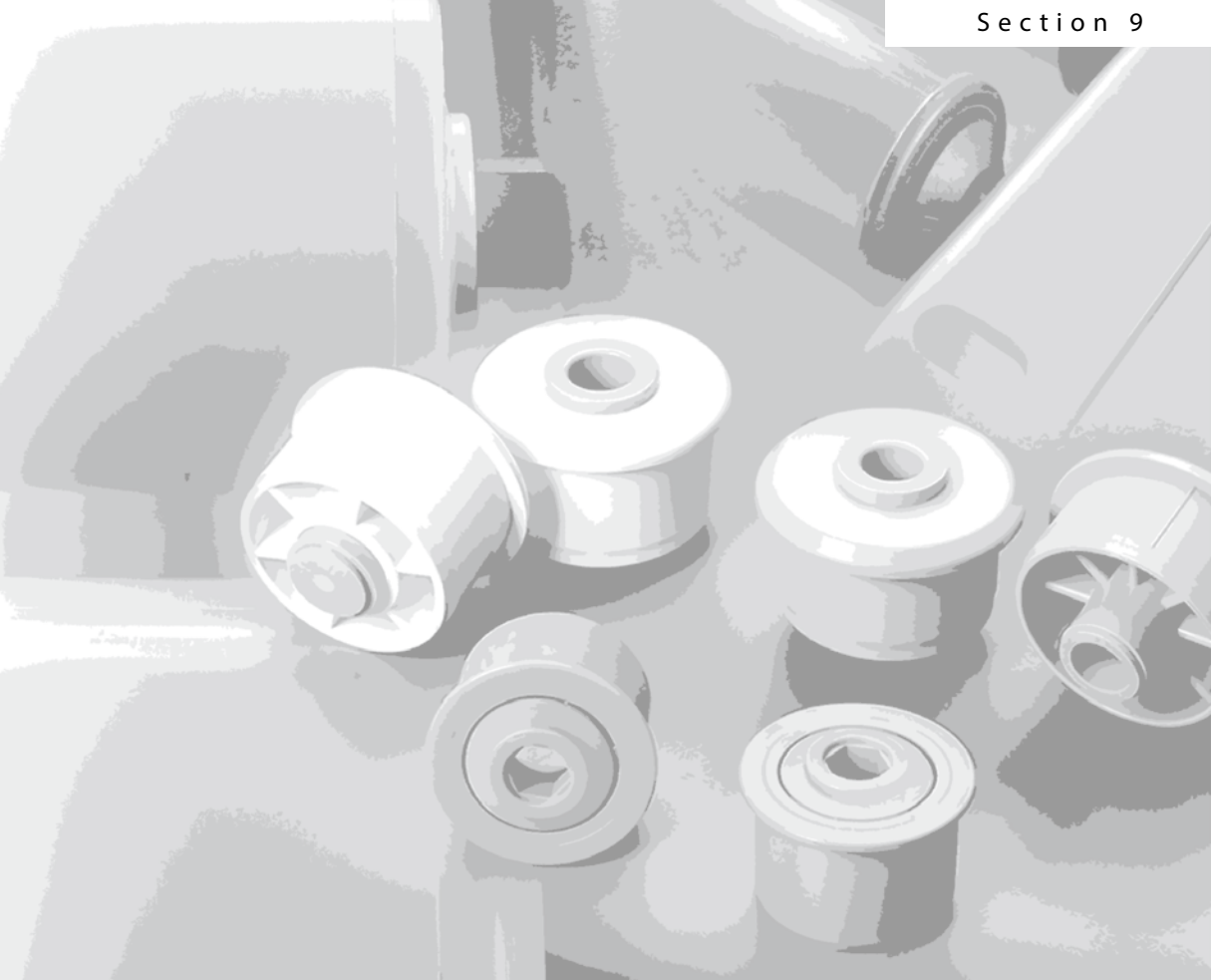

Roller Components... Page 406

- Roller End Bearings
- Nolu-S End Cap Insert
- Conveyor Roll Pins
- Machined Bearings
- ABS End Cap
- Shaft Adapters
- Ball Bearings

Roll-Tech Mini Roller Conveyors

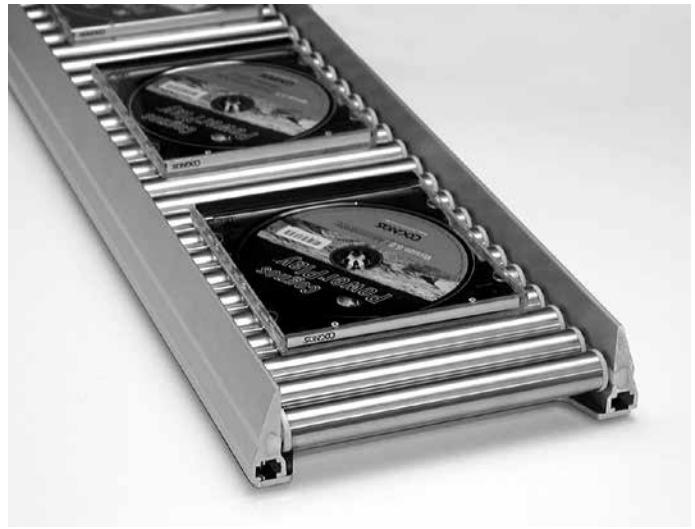

System Plast mini roller conveyors can be used in areas where traditional 1.9 inch diameter (or larger) rollers are too big or are too widely spaced. The close fit and low profile of these mini roller conveyors can help make work areas more efficient. Common applications include: shipping departments, assembly areas, deep shelving, and specialized gravity conveying situations.

- **Perfect for Smaller Containers and Packages**
- **Fully Assembled, Ready to Mount**
- **With or Without Side Guides**
- **Smooth, Quiet Ball Bearing Roller Ends**

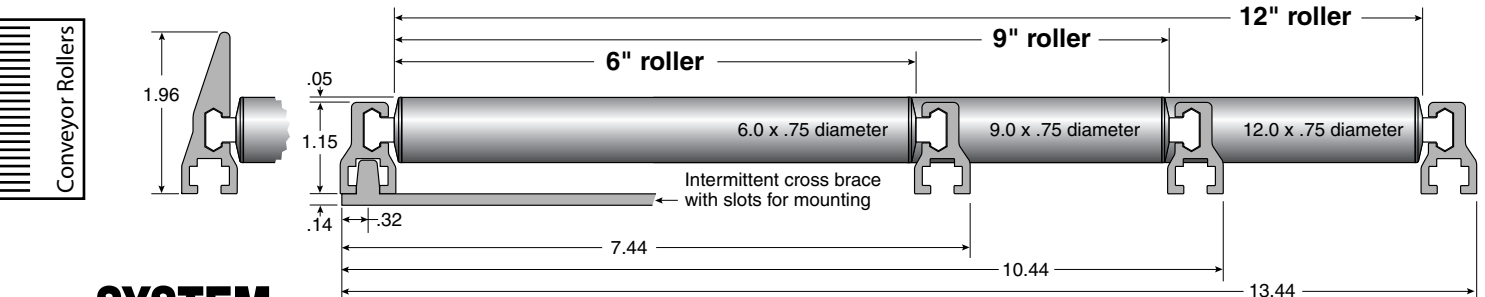
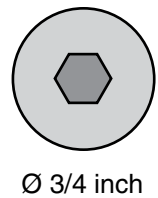
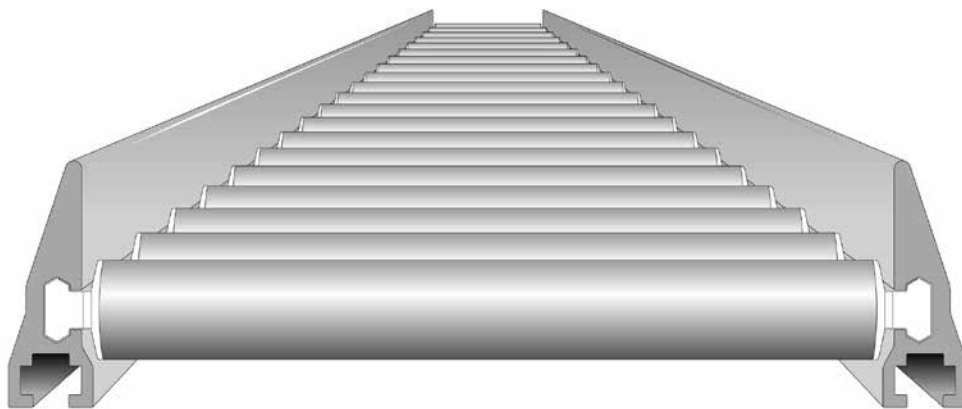
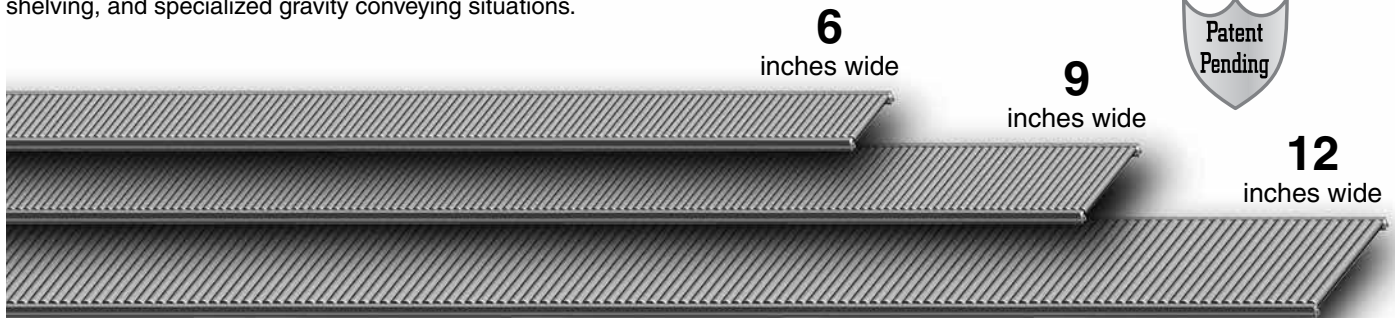

SYSTEM PLAST™

©2015 Regal-Beloit Corporation, All Rights Reserved.

Roll-Tech Mini Roller Conveyors



Flat Roller Bed

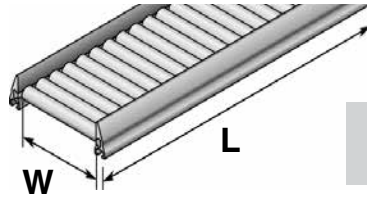

Material: Conveyor side channels: aluminum, cross member mounting brackets: stainless steel, rollers: aluminum or stainless steel.

ARB-AL



Mini Roller Conveyor with Aluminum Rollers

Roller body diameter is .75 inches. Available in 5 or 10 ft. lengths, and 6, 9, or 12 inch widths. Ball bearing roller ends.

Part Number	Roller Width (W) in Inches	Length (L) in Feet
VG-ARB-AL34-BB-6-5	6	5
VG-ARB-AL34-BB-6-10	6	10
VG-ARB-AL34-BB-9-5	9	5
VG-ARB-AL34-BB-9-10	9	10
VG-ARB-AL34-BB-12-5	12	5
VG-ARB-AL34-BB-12-10	12	10

ASRB-AL



Mini Roller Conveyor with Side Guides and Aluminum Rollers

Roller body diameter is .75 inches. Available in 5 or 10 ft. lengths, and 6, 9, or 12 inch widths. Ball bearing roller ends.

VG-ASRB-AL34-BB-6-5	6	5
VG-ASRB-AL34-BB-6-10	6	10
VG-ASRB-AL34-BB-9-5	9	5
VG-ASRB-AL34-BB-9-10	9	10
VG-ASRB-AL34-BB-12-5	12	5
VG-ASRB-AL34-BB-12-10	12	10

ARB-SS



Mini Roller Conveyor with Stainless Steel Rollers

Roller body diameter is .75 inches. Available in 5 or 10 ft. lengths, and 6, 9, or 12 inch widths. Ball bearing roller ends.

VG-ARB-SS34-BB-6-5	6	5
VG-ARB-SS34-BB-9-5	9	5
VG-ARB-SS34-BB-9-10	9	10
VG-ARB-SS34-BB-12-5	12	5
VG-ARB-SS34-BB-12-10	12	10

ASRB-SS



Mini Roller Conveyor with Side Guides and Stainless Steel Rollers

Roller body diameter is .75 inches. Available in 5 or 10 ft. lengths, and 6, 9, or 12 inch widths. Ball bearing roller ends.

VG-ASRB-SS34-BB-6-5	6	5
VG-ASRB-SS34-BB-6-10	6	10
VG-ASRB-SS34-BB-9-5	9	5
VG-ASRB-SS34-BB-9-10	9	10
VG-ASRB-SS34-BB-12-5	12	5
VG-ASRB-SS34-BB-12-10	12	10



Mounting is simple with special slots on each cross member.

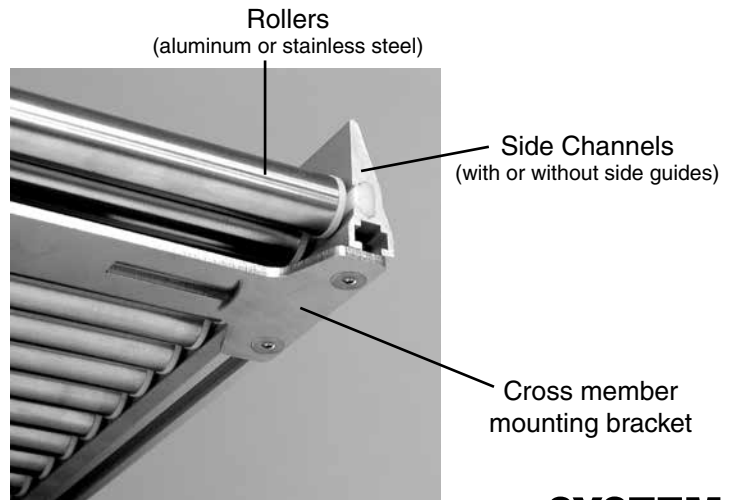

Conveyor Rollers

SYSTEM PLAST™



Return Rollers

The Next Generation of conveyor chain return rollers!

- Sanitary, watertight, sealed
- Excellent wear and chemical resistance
- Low noise, low friction

Our conveyor chain return rollers are made from impact resistant material. They are highly resistant to chemicals and have self lubricating characteristics. A urethane sleeve or ribbed rubber cover option is available for better traction, low noise, and long service life. Other options include a completely solid version, plus side flanges for each type of roller.

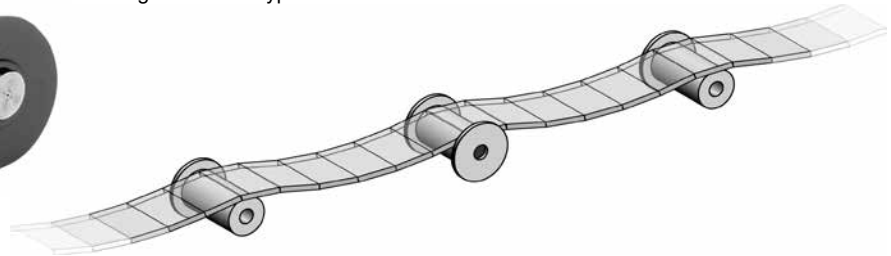
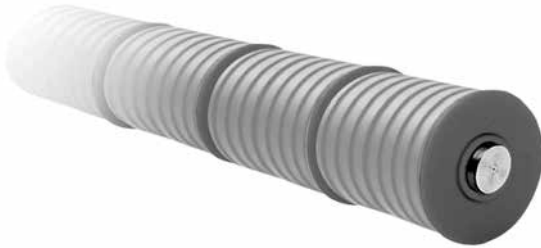

Material: Impact resistant, green HDPE. 3/4" roller is orange HDPE.

R3
Return Roller

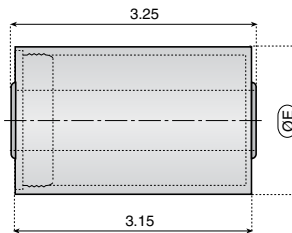

Part Number	Ref. Code	Color (G=Green) (O=Orange)	Shaft Sized Bore Diameter	E Roller Dia.
12831	R3-18-50	G	18mm or 11/16 in.	1.97
12835	R3-18-60	G	18mm or 11/16 in.	2.36
32892	R3-75-50	O	3/4 in.	1.97
32836	R3-75-60	O	3/4 in.	2.36
12892	R3-20-50	G	20mm	1.97
12836	R3-20-60	G	20mm	2.36

R15
Return Roller

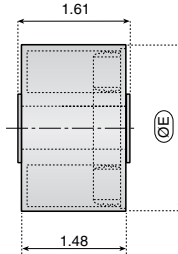

Part Number	Ref. Code	Color (G=Green) (O=Orange)	Shaft Sized Bore Diameter	E Roller Dia.
121965	R15-18-50	G	18mm or 11/16 in.	1.97
122111V	R15-18-60	G	18mm or 11/16 in.	2.36
321966	R15-75-50	O	3/4 in.	1.97
32535	R15-75-60	O	3/4 in.	2.36
12535V	R15-20-60	G	20mm	2.36

RF3
Return Roller with Flange

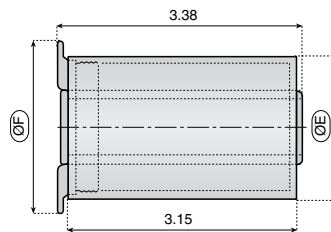

Part Number	Ref. Code	Color (G=Green) (O=Orange)	Shaft Sized Bore Diameter	F Flange Dia.	E Roller Dia.
12833	RF3-18-50	G	18mm or 11/16 in.	2.56	1.97
12837	RF3-18-60	G	18mm or 11/16 in.	2.95	2.36
32763	RF3-75-50	O	3/4 in.	2.56	1.97
32838	RF3-75-60	O	3/4 in.	2.95	2.36
12763	RF3-20-50	G	20mm	2.56	1.97
12838	RF3-20-60	G	20mm	2.95	2.36

RF15
Return Roller with Flange

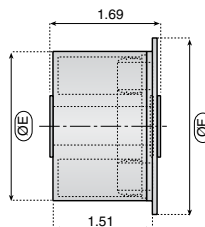

Part Number	Ref. Code	Color (G=Green) (O=Orange)	Shaft Sized Bore Diameter	F Flange Dia.	E Roller Dia.
121969F	RF15-18-50	G	18mm or 11/16 in.	2.56	1.97
122114V	RF15-18-60	G	18mm or 11/16 in.	2.95	2.36
321970F	RF15-75-50	O	3/4 in.	2.56	1.97
32536	RF15-75-60	O	3/4 in.	2.95	2.36
121970F	RF15-20-50	G	20mm	2.56	1.97
12536V	RF15-20-60	G	20mm	2.95	2.36

Conveyor Rollers

Return Rollers

Material: Impact resistant, green HDPE with thermoplastic rubber cover. 3/4" roller is orange HDPE.

R3B

Return Roller with Rubber Surface

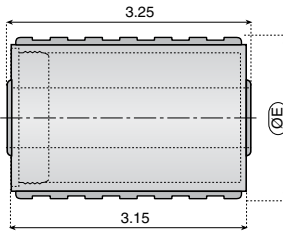

Part Number	Ref. Code	Color (G=Green) (O=Orange)	Shaft Sized Bore Diameter	E Roller Dia.
12831RN	R3B-18-50	G	18mm or 11/16 in.	2.24
12835RN	R3B-18-60	G	18mm or 11/16 in.	2.64
32892RN	R3B-75-50	O	3/4 in.	2.24
32836RN	R3B-75-60	O	3/4 in.	2.64
12892RN	R3B-20-50	G	20mm	2.24
12836RN	R3B-20-60	G	20mm	2.64

R15B

Return Roller with Rubber Surface

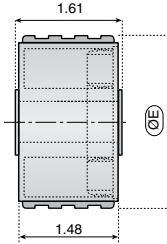

Part Number	Ref. Code	Color (G=Green) (O=Orange)	Shaft Sized Bore Diameter	E Roller Dia.
122111RN	R15B-18-60	G	18mm or 11/16 in.	2.64
321966RN	R15B-75-50	O	3/4 in.	2.24
32535RN	R15B-75-60	O	3/4 in.	2.64
121966RN	R15B-20-50	G	20mm	2.24
12535RN	R15B-20-60	G	20mm	2.64

RF3B

Return Roller with Flange and Rubber Surface

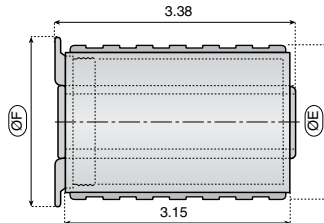

Part Number	Ref. Code	Color (G=Green) (O=Orange)	Shaft Sized Bore Diameter	F Flange Dia.	E Roller Dia.
32763RNF	RF3B-75-50	O	3/4 in.	2.56	2.24
32838RNF	RF3B-75-60	O	3/4 in.	2.95	2.64

RF15B

Return Roller with Flange and Rubber Surface

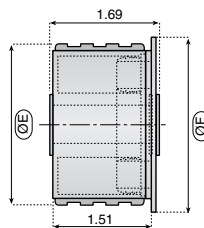

Part Number	Ref. Code	Color (G=Green) (O=Orange)	Shaft Sized Bore Diameter	F Flange Dia.	E Roller Dia.
121969RNF	RF15B-18-50	G	18mm or 11/16 in.	2.56	2.24
122114RN	RF15B-18-60	G	18mm or 11/16 in.	2.95	2.64
321970RNF	RF15B-75-50	O	3/4 in.	2.56	2.24
32536RN	RF15B-75-60	O	3/4 in.	2.95	2.64
121970RNF	RF15B-20-50	G	20mm	2.56	2.24
12536RN	RF15B-20-60	G	20mm	2.95	2.64

SE-582

Threaded End for 3/4 dia. Shafts

Use this insert and 3/4 x .065 tubing to make threaded shafts in minutes, with just a saw. Bypass machine shop delays and use less material. Cut tubing to length, deburr, and press in VG-SE-582 shaft ends.

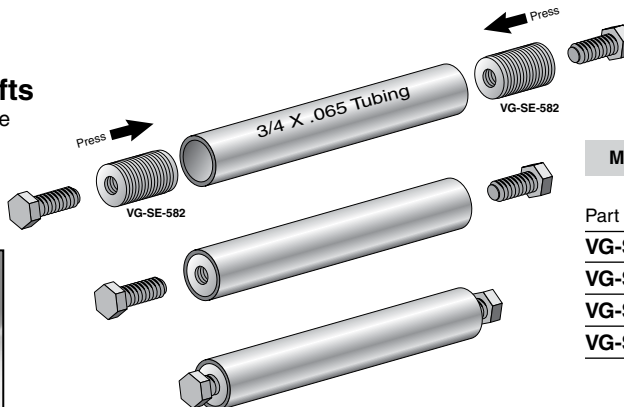

Materials: Stainless Steel.

Part Number	End Insert Thread	Pull Out Load (lbs.)
VG-SE-582-516	5/16-18	900
VG-SE-582-38	3/8-16	900
VG-SE-582-M8	M8	900
VG-SE-582-M10	M10	900

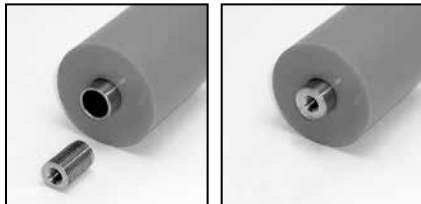

Conveyor Rollers



Return Rollers

RP3

Solid Return Roller

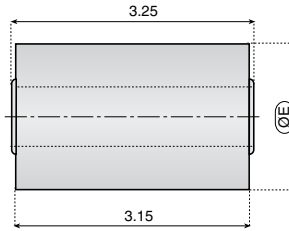

Material: Black Polypropylene.

Part Number	Ref. Code	Color (G=Green) (O=Orange)	Shaft Sized Bore Diameter	E Roller Dia.
121985	RP3-18-50	G	18mm or 11/16 in.	1.97
121987	RP3-18-60	G	18mm or 11/16 in.	2.36
321991	RP3-75-50	O	3/4 in.	1.97
321993	RP3-75-60	O	3/4 in.	2.36
121991	RP3-20-50	G	20mm	1.97

RP3B

Solid Return Roller with Rubber Surface

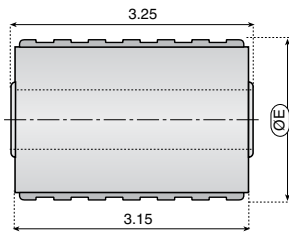

Material: Black Polypropylene with thermoplastic rubber cover.

Part Number	Ref. Code	Color (G=Green) (O=Orange)	Shaft Sized Bore Diameter	E Roller Dia.
121987RN	RP3B-18-60	G	18mm or 11/16 in.	2.64
321993RN	RP3B-75-60	O	3/4 in.	2.64

RF

Roller Flange



Material: Impact resistant, green HDPE.

Flange for 3/4 inch shaft is orange HDPE.

Part Number	Ref. Code	Shaft Sized Bore Diameter	Flange Diameter
12841	RF-18-70	18mm or 11/16 in.	2.75
32534	RF-75-70	3/4 in.	2.75
12534	RF-20-70	20mm	2.75

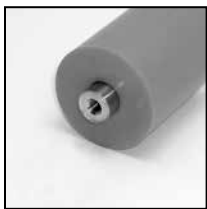

Bypass machine shop delays!

Make 3/4 in. diameter threaded shafts in minutes using VG-SE-582 shaft ends. See page 387 for details

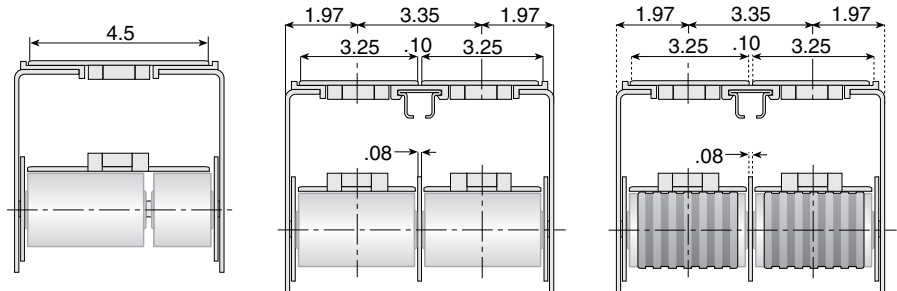

Conveyor Rollers



Our rollers have many varying configurations and material types. Combine this with our custom roller capability, and it becomes necessary to provide some information to help you select the perfect roller for your needs. Conveyor rollers are usually used on either gravity (no power) systems, or on powered systems that use a belt, chain or sprocket to drive the roller.

Driven Systems

In the majority of driven applications, we recommend the use of rollers equipped with our self-lubricating sleeve bearings to obtain the longest service. This is because our sleeve bearings need no maintenance and eliminate all of the problems associated with traditional ball bearings.

Gravity Systems

For gravity systems as well as certain driven applications, we offer different ball bearing options for a variety of applications. From light duty ball bearings for PVC tubing, to heavy-duty ball bearings for steel tubing, System Plast has the ball bearing roller to suit your application.

Sleeve Bearings

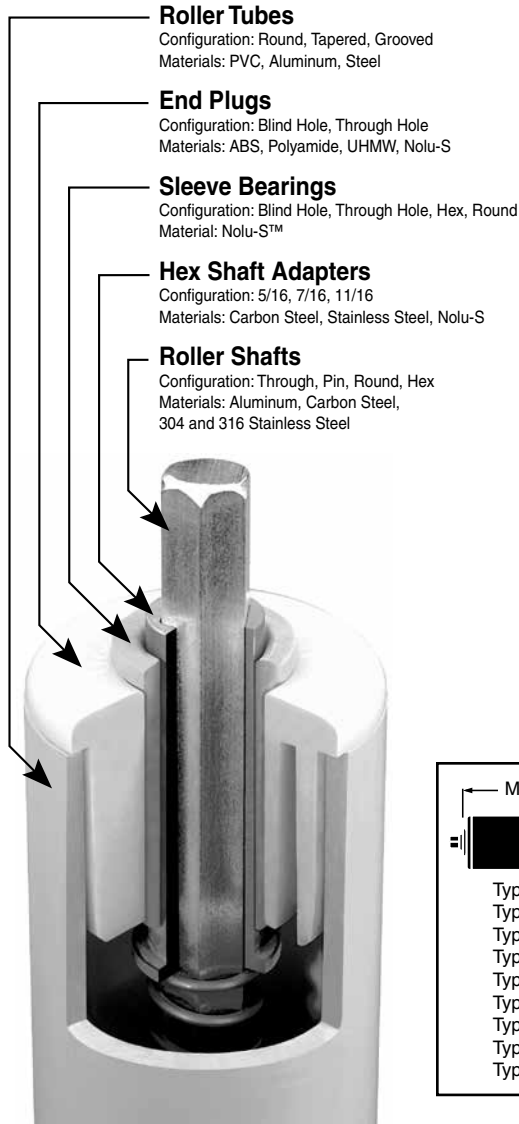

Ball Bearings

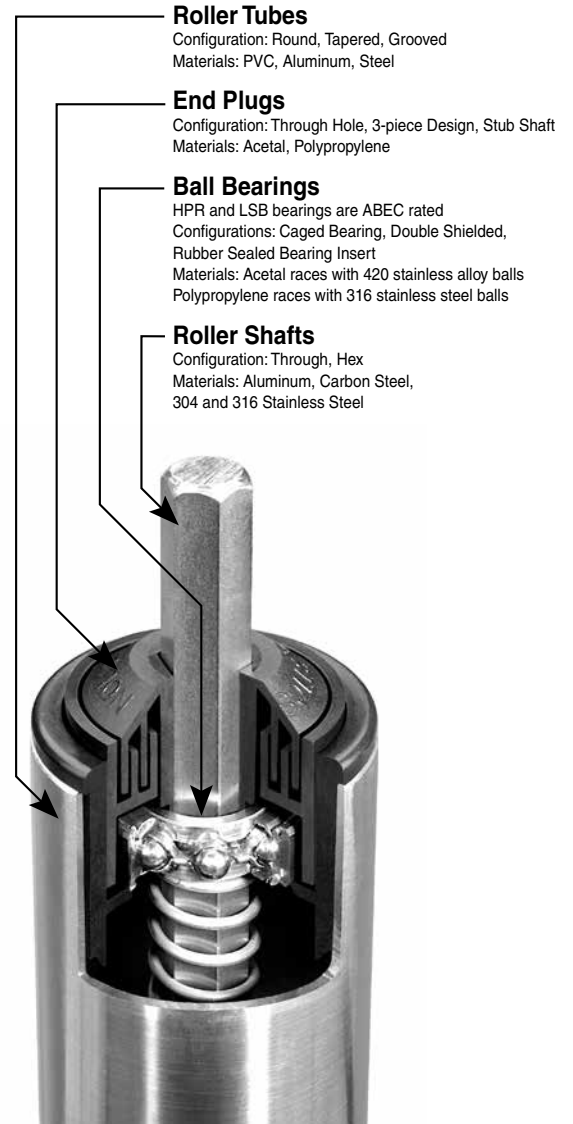

Nolu-S™ Premium low friction bearing material!

Nolu-S is a proprietary alloy of food grade lubricants combined with UHMW. This creates a material which retains most of the properties of UHMW while significantly reducing friction. Nolu-S advantages include protection of expensive mating surfaces, lower noise levels and FDA and USDA approved ingredients.

Conveyor Rollers



"Off The Shelf"

- Steel or PVC Rollers
- Popular Replacement Sizes
- Readily Available Inventory
- Easy Ordering and Re-ordering

These rollers represent our standard product offering. The rollers within each category are the same except for the roller width, which is determined by the distance between the conveyor frames.

See page 413 - 414 for Technical information.

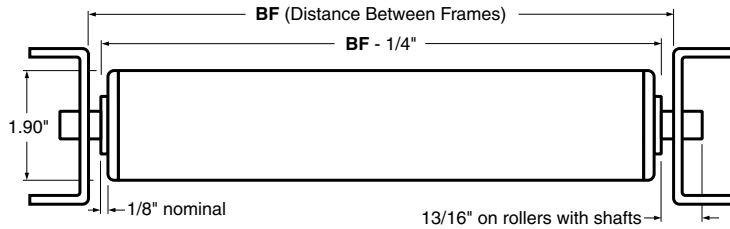

Dimensions for all standard rollers unless otherwise noted

Ideal for dry conditions and lighter loads!

APS

PVC Roller with Sleeve Bearings

Roller body diameter is 1.9 inches. Sleeve bearing material is long lasting Nyla-Ride. Available in 8 standard lengths. To modify this roller, see Type A on page 396.

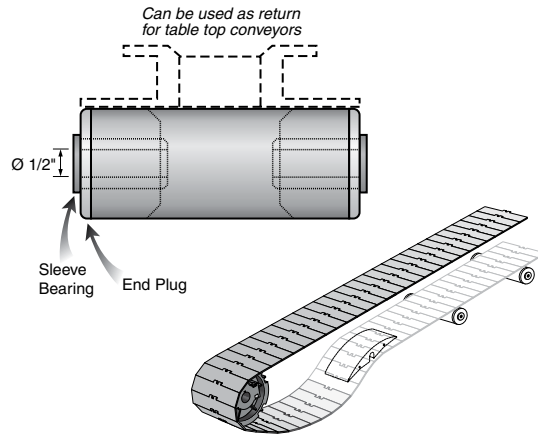

Material: PVC roller body with ABS end plugs and Nyla-Ride sleeve bearings.

Part Number	Chain/Roller width	BF
APS-3.5	3.25	3.50
APS-4.8	4.5	4.75
APS-7.8	7.5	7.75
APS-10.3	10	10.25
APS-13	-	13
APS-16	-	16
APS-18	-	18
APS-22	-	22

APS12

PVC Roller with Sleeve Bearings and Round Thru Shaft

Roller body diameter is 1.9 inches. Internal spring keeps roller centered on the 1/2 in. round shaft. Sleeve bearing material is long lasting Nyla-Ride. Available in 6 standard lengths. To modify this roller, see Type A on page 396.

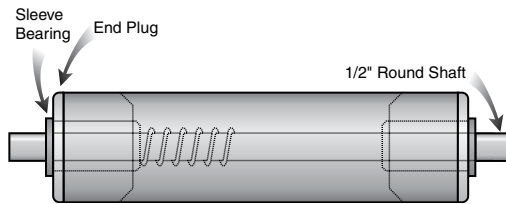

Material: PVC roller body with ABS end plugs and Nyla-Ride sleeve bearings. Carbon steel round shaft.

Part Number	Chain/Roller width	BF
APS12-10.3	10	10.25
APS12-13	-	13
APS12-18	-	18
APS12-22	-	22

APS7

PVC Roller with Sleeve Bearings and Hex Thru Shaft

Roller body diameter is 1.9 inches. Internal spring keeps roller centered on the 7/16 hex shaft. Sleeve bearing material is long lasting Nyla-Ride. Available in 6 standard lengths. To modify this roller, see Type A on page 396.

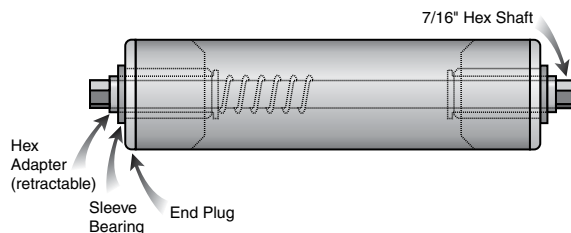

Material: PVC roller body with ABS end plugs and Nyla-Ride sleeve bearings. Carbon steel hex shaft.

Part Number	Chain/Roller width	BF
APS7-7.8	7.5	7.75
APS7-13	-	13
APS7-16	-	16
APS7-22	-	22

Conveyor Rollers



BPS12

PVC Roller with Sleeve Bearings

Roller body diameter is 1.9 inches. Available in 8 standard lengths. Blind hole sleeve bearing material is long lasting Nyla-Ride and will accommodate $\text{\O}1/2"$ stub shafts. **Roller stub shafts not included.** To modify this roller, see Type B on page 396.

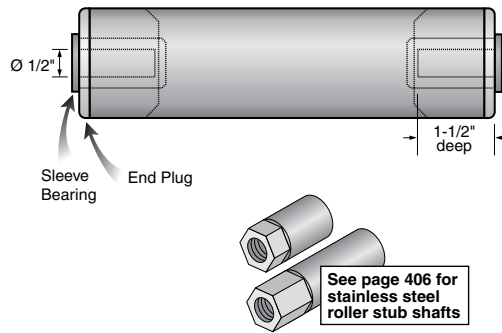

Material: PVC roller body with ABS end plugs and Nyla-Ride sleeve bearings.

Part Number	Chain/Roller width	BF
BPS12-4.8	4.5	4.75
BPS12-7.8	7.5	7.75
BPS12-13	-	13
BPS12-18	-	18
BPS12-22	-	22

DPL7

PVC Roller with Ball Bearings and Hex Thru Shaft

Roller body diameter is 1.9 inches. Internal spring keeps roller centered on the 7/16 hex shaft. Ball bearing material is acetal plastic with 420 stainless steel balls. Available in 6 standard lengths. To modify this roller, see Type D on page 397.

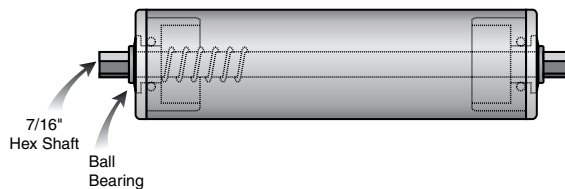

Material: PVC roller body. Ball bearings are acetal plastic with 420 stainless steel balls. Carbon steel hex shaft.

Part Number	BF
DPL7-10.3	10.25
DPL7-13	13
DPL7-16	16
DPL7-18	18
DPL7-22	22

ICD7

Steel Roller for Driven Systems with Ball Bearings and Hex Thru Shaft

Roller body diameter is 1.9 inches. Internal spring keeps roller centered on the 7/16 hex shaft. Ball bearing is labyrinth sealed plastic with a sealed bearing insert. Available in 7 standard lengths. To modify this roller, see Type I on page 400.

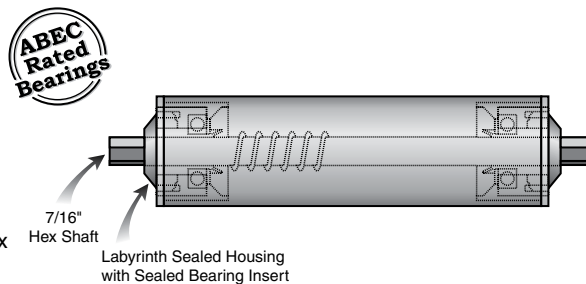

Material: Carbon steel roller body. Ball bearings are labyrinth sealed plastic with a sealed bearing insert. Carbon steel hex shaft.

Part Number	BF
ICD7-10.3	10.3
ICD7-13	13
ICD7-16	16

ICG7

Steel Roller for Gravity Systems with Ball Bearings and Hex Thru Shaft

Roller body diameter is 1.9 inches. Internal spring keeps roller centered on the 7/16 hex shaft. Ball bearing is labyrinth sealed plastic with carbon steel balls. Available in 7 standard lengths. To modify this roller, see Type I on page 400.

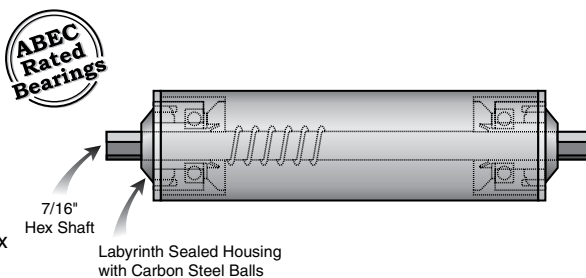

Material: Carbon steel roller body. Ball bearings are labyrinth sealed plastic with carbon steel balls. Carbon steel hex shaft.

Part Number	BF
ICG7-10.3	10.3
ICG7-13	13
ICG7-18	18

Conveyor Rollers



System Plast offers a line of conveyor rollers and components which are engineered to provide totally maintenance free service. These rollers are quiet, need no lubrication, are extremely corrosion resistant, and can be used in wet applications. Contamination does not readily adhere to the surface of our rollers, which helps to keep the conveyor clean

and trouble-free. Our plastic rollers work well with conveyor belts, and can actually increase conveyor belt life through reduced belt abrasion. These rollers are available in a vast selection of sizes, materials and configurations as shown on the following pages. Please call 866-765-8744 to review your design requirements or fax your specifications to 866-447-6587.

Roller Selection Flowchart

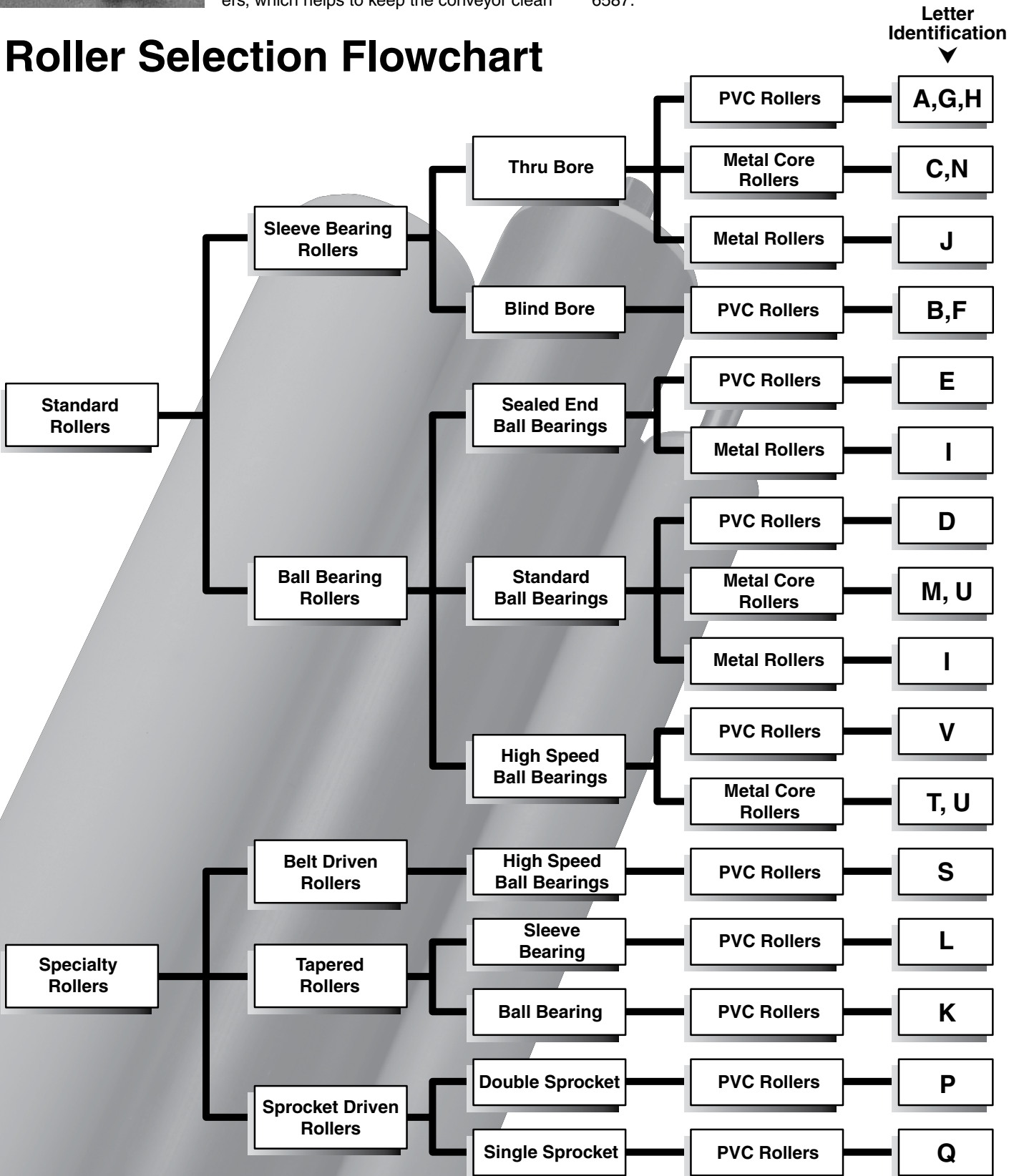

Roller Components

Standard and custom roller options are shown in the chart below.			Roller Type																				
			A	B	C	D	E	F	G	H	I	J	K	L	M	N	P	Q	S	T	U	V	
Shaft	Shape	7/16 hex	●		●				●	●	●	●	●	●	●	●	●	●	●	●	●		
		5/16 hex			●	●																●	●
		1/2 round	●	●	●	●		●	●	●		●		●		●	●	●					
		5/8 round		●																			
		1/4 round																					
		Other round				●	*	●															
	Material	Carbon steel	●		●				●	●	●	●	●	●	●	●	●	●	●	●	●	●	
		304 stainless	●		●	●	●	●	●	●	●	●	●	●	●	●	●	●	●	●	●	●	●
		316 stainless	●		●	●			●	●	●	●	●	●	●	●	●	●	●	●	●	●	●
	Through (included)	●		●	●			●	●	●	●	●	●	●	●	●	●	●	●	●	●	●	
Stub (sold separately)		●		●		●														●	●		
Hex adapter available	●		●				●	●		●		●		●	●	●	●						
Roller	Diameter	.81							●	◆													
		1.06				●			●														
		1.19				●			●														
		1.31				●			●														
		1.66				●			●														
		1.90	●	●	●		●	●	●	●				●	●	●	●	●	◆				
		2.25	●	●		●			●								●	●		◆		●	
		2.38	●	●	●		●	●	●	●						●	●	●					
		2.50	●	●					●								●	●					
		2.88	●	●					●								●	●					
	Material	PVC	●	●			●	●	●	●			●	●	●	●	●	●	●				
		Aluminum			●	●					●									●		●	
		UHMW			●															●			
		Stainless steel								●	●												
		Carbon steel								●	●			●	●								
Urethane																					●		
Tapered											●	●								●			
With sprocket																●	●			●			
Grooved																		●					
Bearing	Type	Sleeve			●		●	●	●		●		●										
		Plug with sleeve	●	●				●								●	●	●					
		Ball				●						●		●					●	●			
		Ball, sealed				●					●											●	
	Material	Plastic with metal balls			●	●			●		●		●						●	●	●		
		Nyla-Ride	●	●												●	●	●			●	●	
		Nolu-S UHMW	●	●	●				●		●		●			●	●	●					
		Acetal					●	●															
UHMW							●		●														

* 5/16 threaded stub shaft included

◆ Roller diameter depends on bearing selection

◆ 2.0 inches

Conveyor Rollers



Rollers

Type A

PVC Roller with High Performance Sleeve Bearing

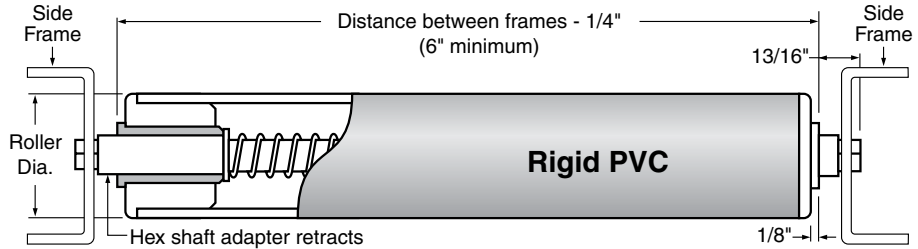

Our most popular all plastic roller, designed for belt driven conveyors and inclined gravity systems. Standard shafts extend 13/16" at each end of a roller. Custom extended shaft lengths are available. This roller can be purchased without a shaft if you prefer (leave shaft information out of part number).

Roller material: beige, rigid PVC.
End plug material: beige ABS.

See page 396 for Type A Roller standard part numbers.

Bearing Type:	Sleeve
Bore Type:	Through
Roller Material:	PVC

Shaft Material		Hex Adapter Material		Roller Diameter		Bearing Material		Distance Between Frames
Part No.	Description	Part No.	Description	Part No.	Description	Part No.	Description	
CS	Carbon steel	C	Carbon steel	R220	1.90"	S	Nolu-S	
304SS	304 stainless	316SS	316 stainless	R250	2.25"			
316SS	316 stainless			R270	2.38"			
				R280	2.50"			
				R320	2.88"			

7/16 hex shaft ▶	A-7/16hex-	<input type="text"/>	<input type="text"/>	<input type="text"/>	<input type="text"/>	<input type="text"/>
1/2" round shaft ▶	A-1/2	<input type="text"/>	<input type="text"/>	<input type="text"/>	<input type="text"/>	<input type="text"/>

Type B

PVC Roller with High Performance Blind Bore Sleeve Bearing

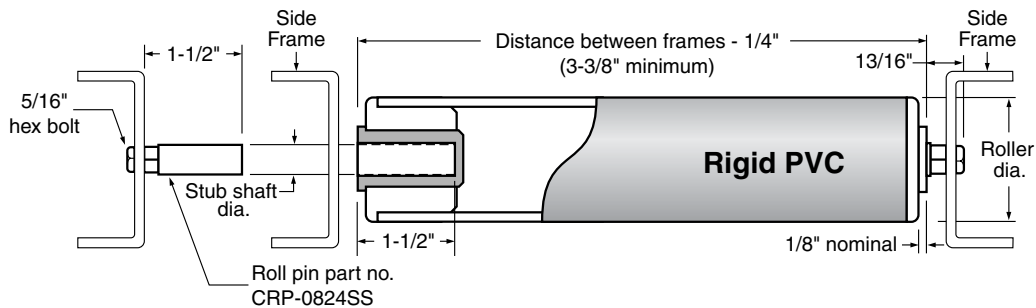
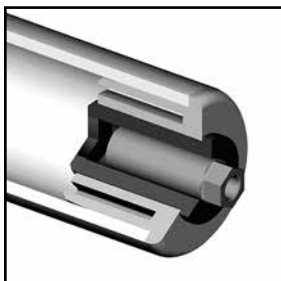

Designed for belt driven conveyors and inclined gravity systems where added cleanliness is required. The blind bore sleeve bearing can accommodate a 1/2" or 5/8" stainless steel stub shaft or extended pin chain attachments. The standard roller is bored to suit part number CRP-0824SS which is 1/2" dia., 316 stainless steel, and can be bolted to your side frame.

Roller material: beige, rigid PVC.
End plug material: beige ABS.

See page 396 for Type B Roller standard part numbers.

Bearing Type:	Sleeve
Bore Type:	Blind
Roller Material:	PVC

Stub Shaft Diameter	Roller Diameter		Bearing Material		Distance Between Frames
Part No.	Description	Part No.	Description		
1/2"	R220	1.90"	S	Nolu-S	
5/8"	R250	2.25"			
	R270	2.38"			
	R280	2.50"			
	R320	2.88"			

B-	<input type="text"/>	<input type="text"/>	<input type="text"/>	<input type="text"/>
-----------	----------------------	----------------------	----------------------	----------------------

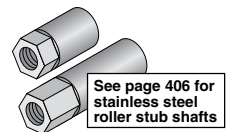

See page 406 for stainless steel roller stub shafts

Conveyor Rollers

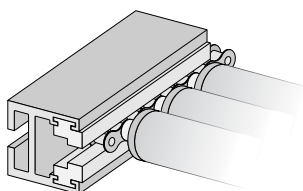



Type C

UHMW Roller with High Performance Sleeve Bearing

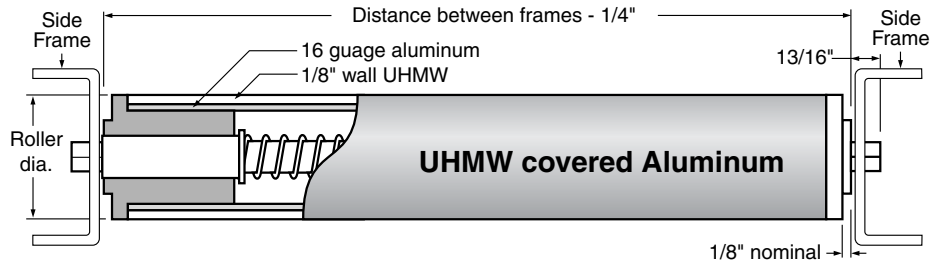
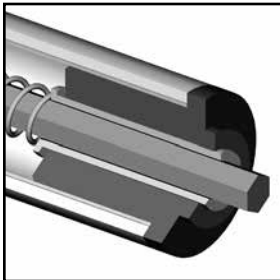

Our UHMW roller, reinforced with an aluminum tube, offers maximum abrasion resistance. Designed primarily for belt driven conveyors, the plastic sleeve bearings is an excellent choice for applications exposed to abrasive or corrosive products, candy production or printing where a non-stick surface is required. Standard shafts extend 13/16" at each end of a roller. Custom extended shaft lengths are available.

Roller material: aluminum, UHMW.

Bearing Type:	Sleeve
Bore Type:	Through
Roller Material:	UHMW covered aluminum

Shaft Diameter		Shaft Material		Hex Adapter Material		Roller Diameter		Bearing Material		Distance Between Frames
Part No.	Description	Part No.	Description	Part No.	Description	Part No.	Description	Part No.	Description	
7/16 hex	7/16" hex	CS	Carbon steel	C	Carbon steel	R220	1.90"	S	Nolu-S	
5/16 hex	5/16" hex	304SS	304 stainless	316SS	316 stainless	R270	2.38"			
1/2	1/2" round	316SS	316 stainless		<i>Use with hex shaft.</i>					

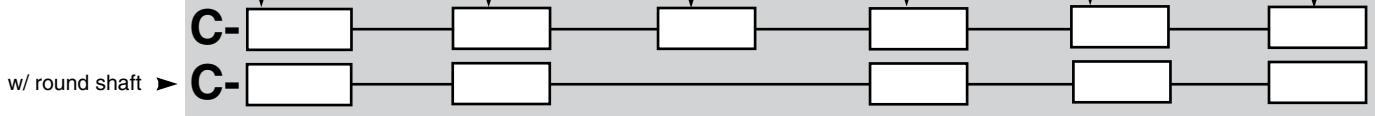

Type D

PVC Roller with Nolu Plastic Ball Bearing

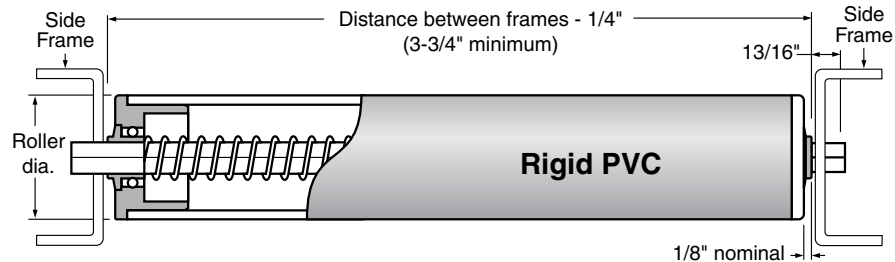
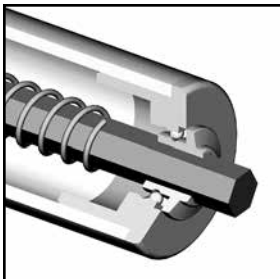

A cost effective lighter duty roller designed primarily for gravity conveyor applications. Standard shafts extend 13/16" at each end of a roller. Custom extended shaft lengths are available.

Roller material: beige, rigid PVC.

Bearing Type:	Ball
Bore Type:	Through
Roller Material:	PVC

See page 397 for Type D Roller standard part numbers.

Shaft Material		Roller Diameter, Shaft Diameter and Bearing Material				Distance Between Frames
Part No.	Description	Part No.	Roller Dia.	Shaft Dia.	Bearing Material	
CS	Carbon steel	NBB110	.81"	1/4" round	Acetal w/ 420 stainless balls	
304SS	304 stainless	NBB130	1.06"	5/16" hex	Acetal w/ 420 stainless balls	
316SS	316 stainless	NBB145	1.19"	5/16" round	Acetal w/ 420 stainless balls	
		NBB150	1.31"	5/16" hex	Acetal w/ 420 stainless balls	
		NBB220	1.90"	7/16" hex	Acetal w/ 420 stainless balls	
		SPB220	1.90"	7/16" hex	Polypropylene w/ 316 stainless balls	



Conveyor Rollers



Type E

PVC Roller with Sealed End Ball Bearing

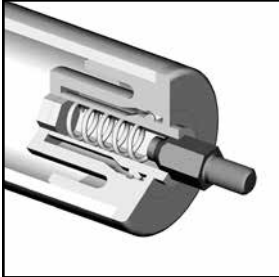

Bearing Type:	Ball
Bore Type:	Blind
Roller Material:	PVC

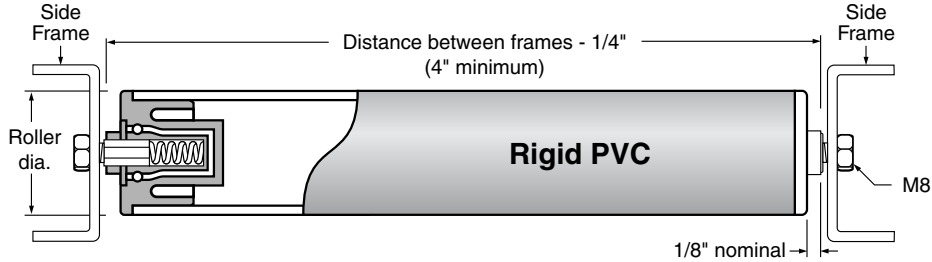

Our low friction roller with sealed end bearings prevents fluids and other contaminants from entering the tube. Useful in the processing industry due to the corrosion resistant materials that are USDA accepted for incidental contact with food products. Spring loaded, stainless steel stub shafts ease the assembly into a frame capable of accepting the M8 threaded attachments,

Roller material: beige, rigid PVC.

Estimated Bearing Life For Plastic Ball Bearings

Radial load lbs. per roller: 5 10 15

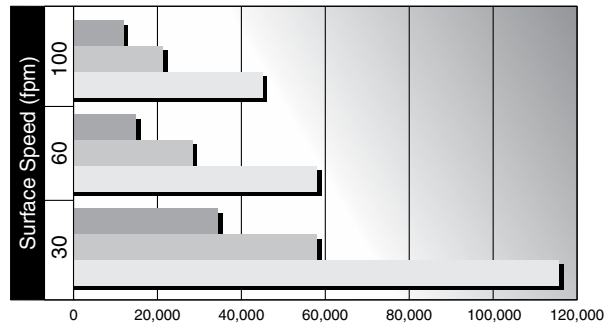

Estimated bearing life will be reduced by impact loads and by exposure of contaminants. If the distance between frames is greater than 12", load capacity will be limited by the rigidity of the PVC tubing.

Roller Diameter	Part No.	Description	Distance Between Frames
SBR220	1.90"		
SBR270	2.37"		

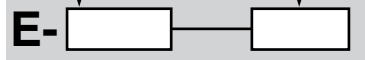

Type F

PVC Roller with Blind-Bore Sleeve Bearing

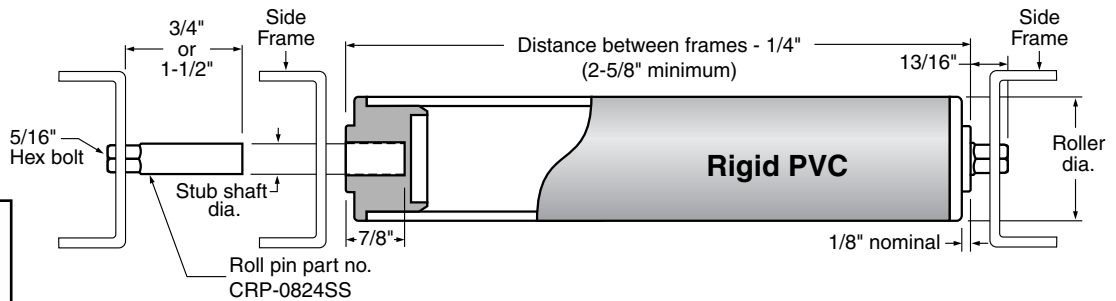
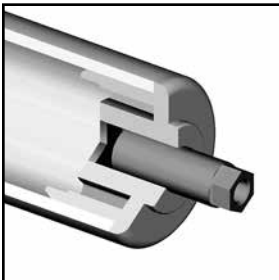

Type F roller is designed to provide added cleanliness and reduce potential areas of contamination. The one piece, blind bore sleeve bearing can accommodate a stainless steel roller stub shaft or extended pin chain attachment up to $\text{\O} 5/8$ ". Unless specified otherwise, rollers come with $\text{\O} 1/2$ " bores that can be used with our $\text{\O} 1/2$ ", 316 stainless steel roller stub shafts (see page 406) which are bolted directly to the side frame.

Roller material: beige, rigid PVC.
End plugs/bearing: beige acetal.

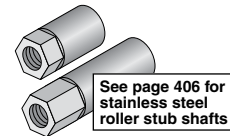

See page 406 for stainless steel roller stub shafts

Stub Shaft Diameter	Roller Diameter	Part No.	Description	Distance Between Frames
1/2" (other)	NR220	1.90"		
	NR270	2.38"		





Type G

PVC Roller with Sleeve Bearings

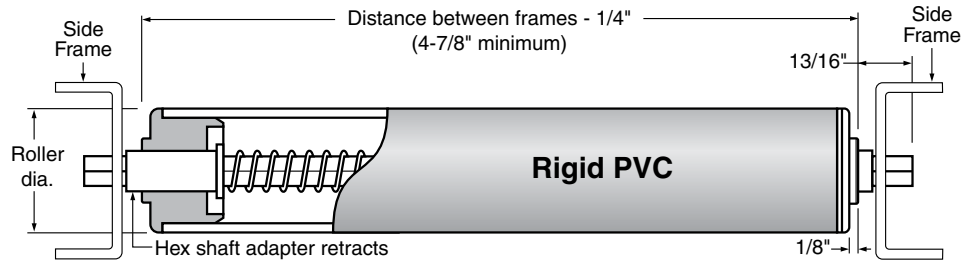
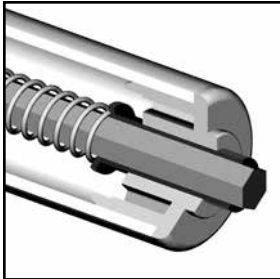

Our economical, light duty roller with a selection of steel shaft assemblies. Designed to support the return side of belt conveyors and inclined gravity systems. Standard shafts extend 13/16" at each end of a roller. Custom extended shaft lengths are available. This roller can be purchased without a shaft if you prefer (leave shaft information out of part number).

Roller material: beige, rigid PVC.
End plug material: beige acetal.
Bearing material: beige acetal.

Bearing Type:	Sleeve
Bore Type:	Through
Roller Material:	PVC

	Shaft Material Part No. Description	Hex Adapter Material Part No. Description	Roller Diameter Part No. Description	Distance Between Frames
7/16 hex shaft ➤	CS Carbon steel	C Carbon steel	NR220 1.90"	
	304SS 304 stainless	316SS 316 stainless	NR270 2.38"	
	316SS 316 stainless	S Nolu-S		
		<i>Use with hex shaft.</i>		
w/ round shaft ➤	G-7/16hex-			
	G-1/2			

Type H

PVC Roller with One Piece End Plugs of Sleeve Bearing Material

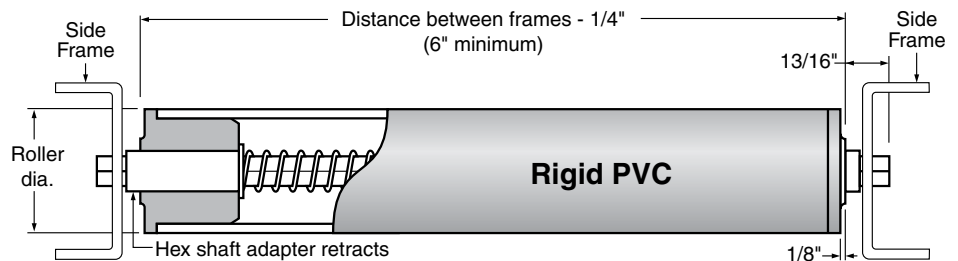
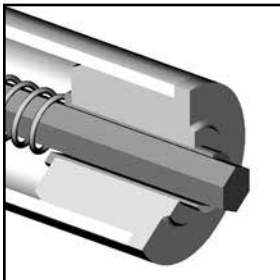

Designed for belt driven conveyors offering all the advantages of a plastic roller and eliminates all the problems associated with the use of ball bearings. Standard shafts extend 13/16" at each end of a roller. This roller can be purchased without a shaft if you prefer (leave shaft information out of part number).

Roller material: beige, rigid PVC.
Bearing material: UHMW, Nolu-S.

Bearing Type:	Sleeve
Bore Type:	Through
Roller Material:	PVC

	Shaft Material Part No. Description	Hex Adapter Material Part No. Description	Roller Diameter and Material UHMW# Nolu-S # Description	Distance Between Frames
7/16 hex shaft	CS Carbon steel	C Carbon steel	HT130 or ST130 1.06"	
	304SS 304 stainless	316SS 316 stainless	HT145 or ST145 1.19"	
	316SS 316 stainless		HR190 or ST190 1.66"	
			HR220 or SR220 1.90"	
			HR250 or SR250 2.25"	
			HR270 or SR270 2.38"	
			HR280 or SR280 2.5"	
			HR320 or SR320 2.88"	
		<i>Use with hex shaft.</i>		
w/ round shaft	H-7/16hex-			
	H-1/2			

Conveyor Rollers



Type I

Steel Roller with Plastic Ball Bearing

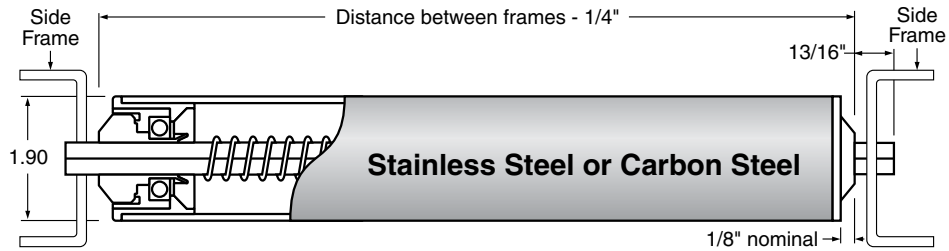
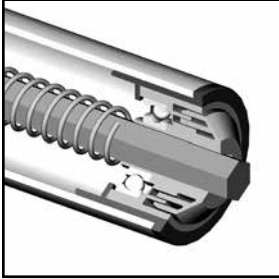

Designed primarily for belt driven conveyors and inclined gravity systems where a heavy duty roller is required. Standard shafts are 7/16" hex and extend 13/16" at each end of a roller. Custom extended shaft lengths are available.

Roller material: stainless or carbon steel.

See page 393 for Type I Roller standard part numbers.

Bearing Type:	Ball
Bore Type:	Through
Roller Material:	Steel

Shaft Material	Bearing	Shaft Diameter	Tubing Material	Distance
Part No. Description	Part No. Description	Description	Part No. Description	Between Frames
CS Carbon steel	222LSB-224-01 Plastic housing with carbon steel caged bearing insert	7/16	2 Carbon steel	
304SS 304 stainless	222LSB-224-02 Plastic housing with carbon steel double shielded bearing insert		3 304 stainless	
316SS 316 stainless	222LSB-224-03 Plastic housing with carbon steel double rubber sealed bearing insert			



Type J

Steel / Aluminum Roller with Non-Metallic Sleeve Bearings

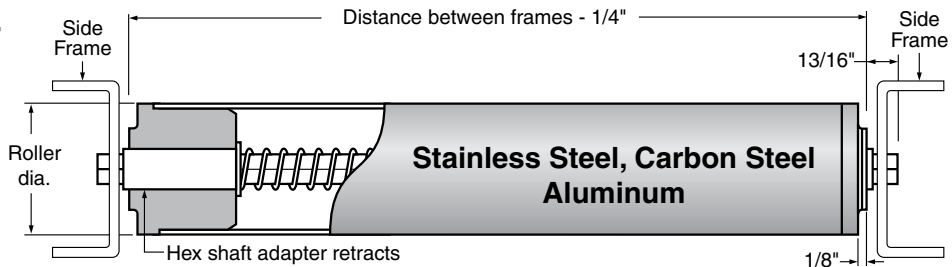
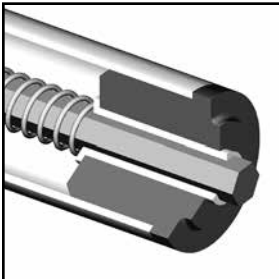

Roller can be produced from most standard tube sizes and using a conveyor roll end bearing from the table on page 407. Designed primarily for belt driven conveyors and inclined gravity systems. It provides the same rigidity as other metal tube rollers and yet eliminates all the problems associated with the use of ball bearings. Standard shafts extend 13/16" at each end of a roller. Custom extended shaft lengths are available. This roller can be purchased without a shaft if you prefer (leave shaft information out of part number).

Roller material: stock steels or aluminum.

Bearing Type:	Sleeve
Bore Type:	Through
Roller Material:	Steel

Shaft Material	Hex Adapter Material	Roller Dia., Gage,	Tubing Material	Distance
Part No. Description	Part No. Description	Bearing Material & Bore size (see pg. 451) (e.g. HR-234J)	Part No. Description	Between Frames
CS Carbon steel	C Carbon steel		2 Carbon steel	
304SS 304 stainless	316SS 316 stainless		3 304 stainless	
316SS 316 stainless			5 Aluminum	

Use with hex shaft.





Type K

Tapered PVC Roller with Plastic Ball Bearing

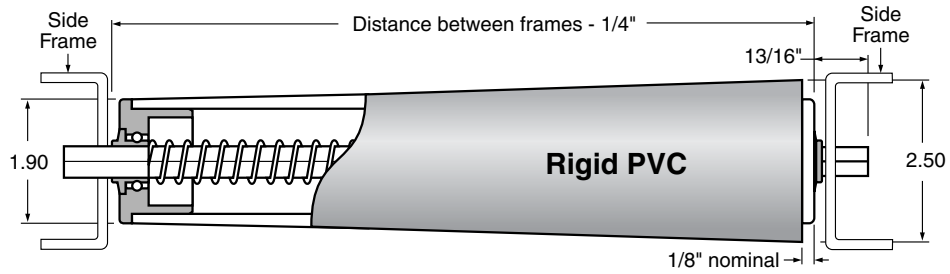
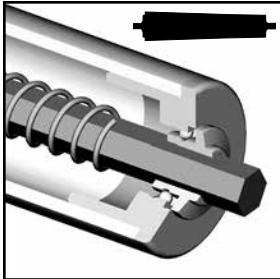

Designed primarily for gravity conveyors where a clean, corrosion free environment is required. The bearings are unaffected by most normal washdown procedures. Standard shafts extend 13/16" at each end of a roller. Custom extended shaft lengths are available.

Roller material: gray, rigid PVC hollow bar.

Bearing Type:	Ball
Bore Type:	Through
Roller Material:	PVC

Shaft Material	Roller Diameter, Shaft Diameter and Bearing Material	Distance Between Frames
Part No. Description	Part No. Roller Dia. Shaft Dia. Bearing Material	
CS Carbon steel	NBB220 1.90" 7/16" hex Acetal w/ 420 stainless balls	↓
304SS 304 stainless	SPB220 1.90" 7/16" hex Polypropylene w/ 316 stainless balls	
316SS 316 stainless		

K-	<input type="text"/>	<input type="text"/>	<input type="text"/>
-----------	----------------------	----------------------	----------------------

Type L

Tapered PVC Roller with High Performance Sleeve Bearings

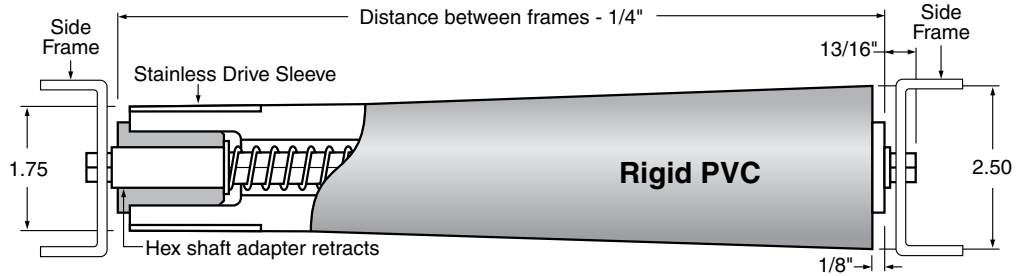
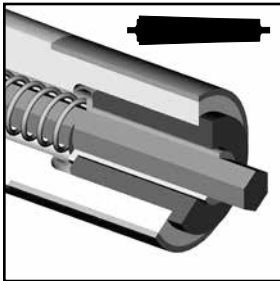

Designed for belt driven systems or can be fitted with UHMW sprockets. Standard shafts extend 13/16" at each end of a roller. Custom extended shaft lengths are available.

Roller material: gray, rigid PVC hollow bar.

Bearing Type:	Sleeve
Bore Type:	Through
Roller Material:	PVC

Shaft Material	Hex Adapter Material	Bearing Material	Distance Between Frames
Part No. Description	Part No. Description	Part No. Description	
CS Carbon steel	C Carbon steel	S Nolu-S	↓
304SS 304 stainless	316SS 316 stainless		
316SS 316 stainless			

7/16 hex shaft ▶	L-7/16hex-	<input type="text"/>	<input type="text"/>	<input type="text"/>	<input type="text"/>
w/ round shaft ▶	L-1/2	<input type="text"/>	<input type="text"/>	<input type="text"/>	<input type="text"/>

Conveyor Rollers



Rollers

Type M

Steel Reinforced PVC Roller with Plastic Ball Bearing

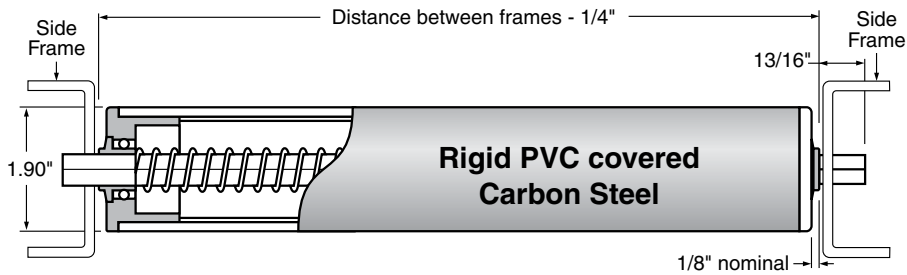
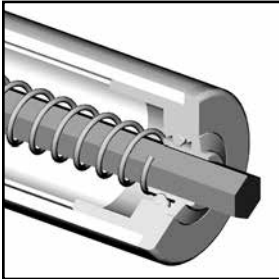

Designed primarily for gravity conveyors where a clean, corrosion free environment is required. The reinforcing tube will increase the load carrying capacity to the limit of the bearings. Standard shafts extend 13/16" at each end of a roller. Custom extended shaft lengths are available.

Roller material: beige, rigid PVC over carbon steel.

Bearing Type:	Ball
Bore Type:	Through
Roller Material:	PVC and steel

Shaft Material	Roller Diameter, Shaft Diameter and Bearing Material			Distance Between Frames		
Part No.	Description	Part No.	Roller Dia.	Shaft Dia.	Bearing Material	
CS	Carbon steel	NBB220	1.90"	7/16" hex	Acetal w/ 420 stainless balls	↓
304SS	304 stainless	SPB220	1.90"	7/16" hex	Polypropylene w/ 316 stainless balls	
316SS	316 stainless					

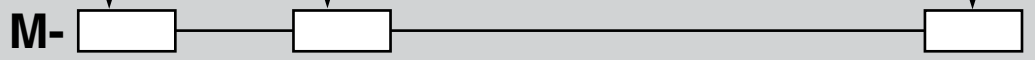

Type N

Steel Reinforced PVC Roller with High Performance Sleeve Bearings

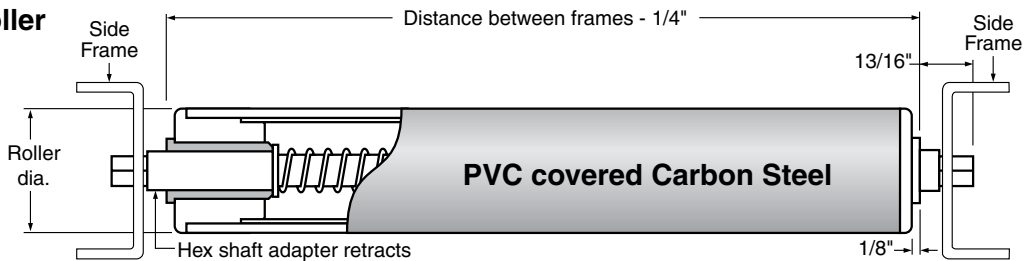
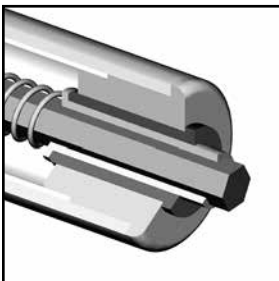

Designed primarily for belt driven conveyors and inclined gravity systems. Offers all the advantages of a plastic roller and eliminates the problem associated with the use of ball bearings. Standard shafts extend 13/16" at each end of a roller. Custom extended shaft lengths are available.

Roller material: beige, rigid PVC over carbon steel.
End Plug material: beige, ABS.

Bearing Type:	Sleeve
Bore Type:	Through
Roller Material:	PVC and steel

Shaft Material	Hex Adapter Material		Roller Diameter		Bearing Material		Distance Between Frames	
Part No.	Description	Part No.	Description	Part No.	Description	Part No.	Description	
CS	Carbon steel	C	Carbon steel	R220R	1.90"	S	Nolu-S	↓
304SS	304 stainless	316SS	316 stainless	R270R	2.38"			
316SS	316 stainless							

7/16 hex shaft ▶

w/ round shaft ▶

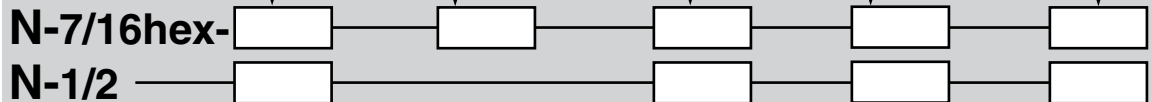

Conveyor Rollers



Type P

Double Sprocket PVC Roller with High Performance Sleeve Bearings

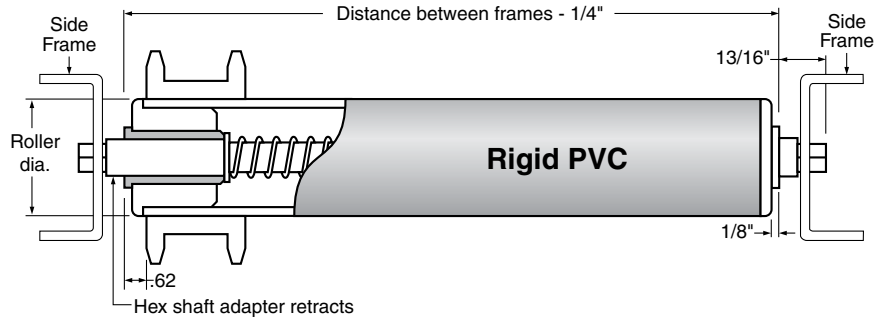
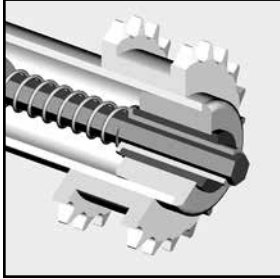

Our Type A roller with a UHMW double sprocket is available for various roller chains. In a driven system, the need for lubrication is eliminated. Better service life and chain wear is reduced. Noise levels are significantly reduced and the roller gains easy acceptance by the USDA and FDA. Standard shafts extend 13/16" at each end of a roller. Custom extended shaft lengths are available.

Roller material: beige, rigid PVC.
End Plug material: beige, ABS.

Bearing Type:	Sleeve
Bore Type:	Through
Roller Material:	PVC

Shaft Material	Hex Adapter Material	Roller Diameter	Bearing Material	Roller Chain	Number of	Distance
Part No.	Part No.	Part No.	Part No.	Number	Teeth	Between
Description	Description	Desc.	Desc.			Frames
CS Carbon steel	C Carbon steel	R220 1.90"	S Nolu-S			
304SS 304 stainless	316SS 316 stainless	R250 2.25"				
316SS 316 stainless		R270 2.38"				
		R280 2.50"				

7/16 hex shaft	P-7/16hex-	<input type="text"/>	<input type="text"/>	<input type="text"/>	<input type="text"/>	<input type="text"/>	<input type="text"/>
w/ round shaft	P-1/2	<input type="text"/>	<input type="text"/>	<input type="text"/>	<input type="text"/>	<input type="text"/>	<input type="text"/>

Type Q

Single Sprocket PVC Roller with High Performance Sleeve Bearings

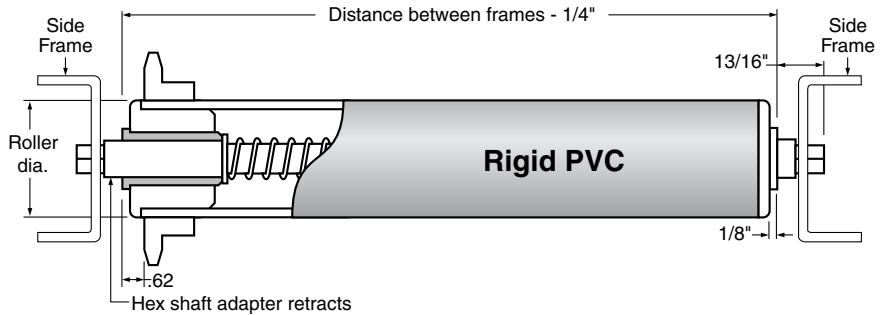
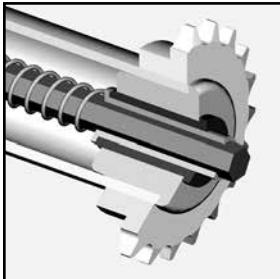

Our Type A roller with a UHMW single sprocket is available for various roller chains. In a driven system, the need for lubrication is eliminated. Better service life and chain wear is reduced. Noise levels are significantly reduced and the roller gains easy acceptance by the USDA and FDA. Standard shafts extend 13/16" at each end of a roller. Custom extended shaft lengths are available.

Roller material: beige, rigid PVC.
End Plug material: beige, ABS.

Bearing Type:	Sleeve
Bore Type:	Through
Roller Material:	PVC

Shaft Material	Hex Adapter Material	Roller Diameter	Bearing Material	Roller Chain	Number of	Distance
Part No.	Part No.	Part No.	Part No.	Number	Teeth	Between
Description	Description	Desc.	Desc.			Frames
CS Carbon steel	C Carbon steel	R220 1.90"	S Nolu-S			
304SS 304 stainless	316SS 316 stainless	R250 2.25"				
316SS 316 stainless		R270 2.38"				
		R280 2.50"				

7/16 hex shaft	Q-7/16hex-	<input type="text"/>	<input type="text"/>	<input type="text"/>	<input type="text"/>	<input type="text"/>	<input type="text"/>
w/ round shaft	Q-1/2	<input type="text"/>	<input type="text"/>	<input type="text"/>	<input type="text"/>	<input type="text"/>	<input type="text"/>

Conveyor Rollers



Type S



PVC Line Shaft Roller with Precision Ball Bearing

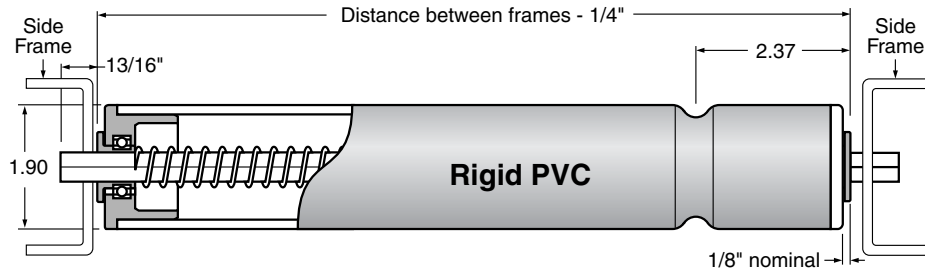
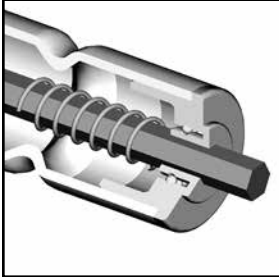

Plastic line shaft conveyor roller designed with a spring loaded 7/16" hex shaft. Noise levels are significantly reduced and surface build up is minimized. Standard shafts extend 13/16" at each end of a roller. Custom extended shaft lengths are available.

Roller material: beige, rigid PVC.

"O" ring groove material: machined into PVC.

Bearing is HPR-220 series precision ball bearing mounted in reinforced polypropylene.

Bearing Type:	Ball
Bore Type:	Through
Roller Material:	PVC

Shaft Material		Belt Diameter		Distance Between Frames
Part No.	Description	Part No.	Description	
CS	Carbon steel	3/16	3/16"	↓
304SS	304 stainless	1/4	1/4"	
316SS	316 stainless			

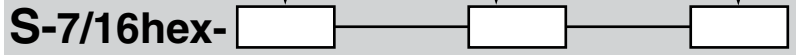

Type T



Aluminum reinforced UHMW Roller with Precision Ball Bearing

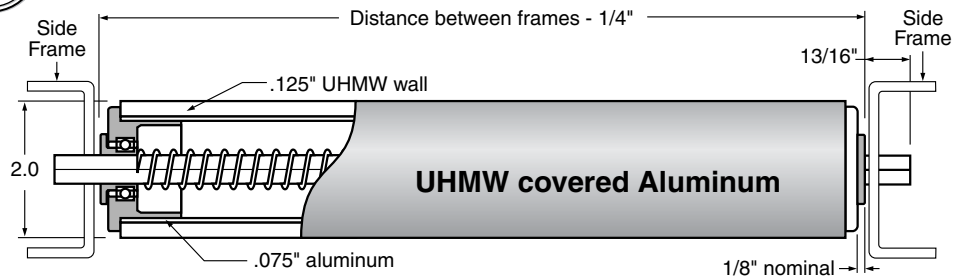
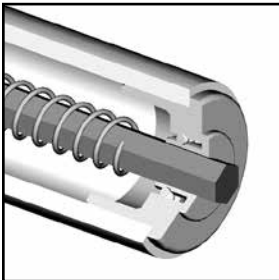

Maximum abrasion resistant roller, reinforced with an aluminum tube. Fitted with a high performance bearing assembly that provides the lowest coefficient of friction, excellent load carrying capacity and high speed capability in one roller. Noise levels are significantly reduced and surface build up is minimized. The UHMW tube offers a great non-stick roller surface for applications such as candy production or printing. Standard shafts extend 13/16" at each end of a roller. Custom extended shaft lengths are available.

Roller material: UHMW, aluminum.

Bearing is HPR-220 series precision ball bearing mounted in reinforced polypropylene.

Bearing Type:	Ball
Bore Type:	Through
Roller Material:	UHMW & Aluminum

Shaft Material		Distance Between Frames
Part No.	Description	
CS	Carbon Steel	↓
304SS	304 stainless	
316SS	316 stainless	



Conveyor Rollers



Type U

Urethane Covered Steel Roller with Plastic Ball Bearing

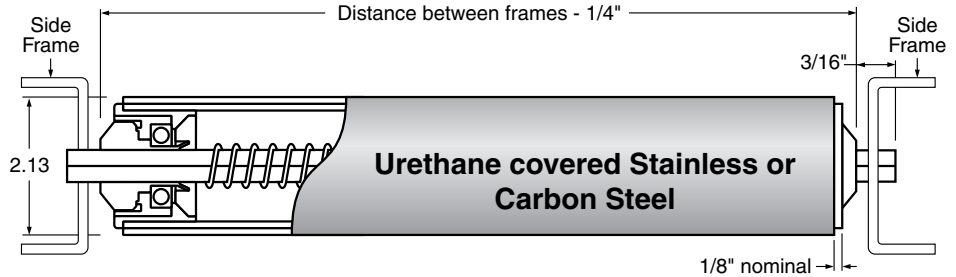
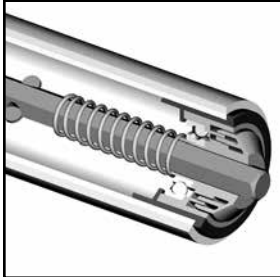

Bearing Type:	Ball
Bore Type:	Through
Roller Material:	Stainless or Carbon Steel

Designed primarily for belt driven conveyors and inclined gravity systems where a heavy duty roller is required. Urethane covering helps protect heavy products that require a flawless cosmetic appearance. Standard shafts are 7/16" hex and extend 13/16" at each end of a roller. Custom extended shaft lengths are available.

Roller material: stainless or carbon steel.

Shaft Material	Bearing	Description	Shaft Diameter	Tubing Material	Distance
Part No.	Part No.		Description	Part No.	Between
CS	222LSB-224-01	Plastic housing with carbon steel insert	7/16	2	Frames
304SS	222LSB-224-02	Plastic housing with carbon steel double shielded bearing insert		3	
316SS	222LSB-224-03	Plastic housing with carbon steel double rubber sealed bearing insert		304 stainless	

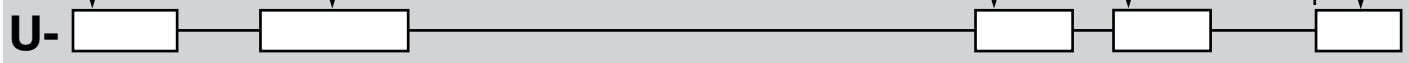

Type V

PVC Free-Turning Roller with Precision Ball Bearing

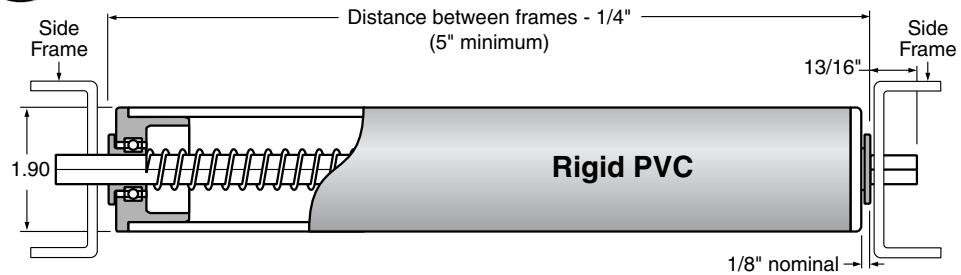
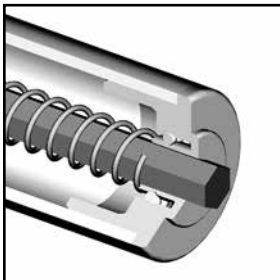

Bearing Type:	Ball
Bore Type:	Through
Roller Material:	PVC

Free turning conveyor roller that is ideal for gravity systems and the precision bearing is also designed for continuous use in driven systems, even at high speeds. Noise levels are significantly reduced and surface build up is minimized. Standard shafts extend 13/16" at each end of a roller. Custom extended shaft lengths are available.

Roller material: beige, rigid PVC.

Bearing is HPR-220 series precision ball bearing mounted in reinforced polypropylene.

Shaft Material	Distance
Part No.	Between
CS	Frames
304SS	
316SS	



Conveyor Rollers



Machined Roller End Bearings

Roller End Bearings

We constantly manufacture nonstandard rollers to solve design problems and offer maintenance free service in a specific environment. Each of these products makes use of our high performance bearing materials.

How To Order Conveyor Roller End Bearings:

The standard part numbers in our tables comprise a full line of roller end bearings manufactured from white UHMW (part numbers starting with "H"). If a custom size is required, provide us with your tubing outside diameter, the gauge thickness and shaft diameter. If an alternative material is required, revise the part number prefix as follows:

Nolu-S, use the letter "S" in place of "H"

Nolu-S is a proprietary alloy of food grade lubricants combined with UHMW. This creates a material which retains most of the properties of UHMW while significantly reducing friction. Nolu-S advantages include protection of expensive mating surfaces, lower noise levels and FDA and USDA approved ingredients.

Example: **HR-190** uses UHMW, **SR-190** uses Nolu-S

A bearing will be supplied with a bore designed for a 1/2" diameter shaft unless a suffix letter is added to the part number from the list below.

*Additional Bores

A=3/16" No Letter= 1/2" M=13/16"

B= 1/4" H= 9/16" N=7/8"

C= 5/16" J= 5/8" Q= 15/16"

E=3/8" K= 11/16" T=1"

F= 7/16" L= 3/4" U= 1-1/16"

Example: **SR-190J**

HT

Light Duty Bearings

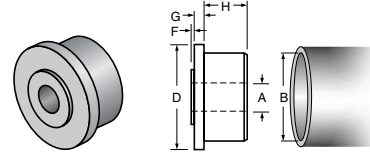

Part Number	A Bore	D Tube OD	Gauge Tube	Tube Wall	B Tube ID	F	G	H
HT-072A	3/16	1/2	20	.035	.430	1/16	1/8	5/16
HT-073A	3/16	1/2	18	.049	.402	1/16	1/8	5/16
HT-082A	3/16	5/8	20	.035	.555	1/16	1/8	5/16
HT-090A	3/16	.706	1/2 EMT	.042	.622	1/16	1/8	1/2
HT-102B	1/4	3/4	20	.035	.680	1/16	1/8	1/2
HT-104B	1/4	3/4	16	.065	.620	1/16	1/8	1/2
HT-112B	1/4	7/8	20	.035	.805	1/16	1/8	1/2
HT-113B	1/4	7/8	18	.049	.777	1/16	1/8	1/2
HT-120B	1/4	.922	3/4 EMT	.049	.824	1/16	1/8	1/2
HT-122E	3/8	1	20	.035	.930	1/16	1/8	1/2
HT-127E	3/8	1	17	.058	.884	1/16	1/8	1/2
HT-124E	3/8	1	16	.065	.870	1/16	1/8	1/2
HT-137E	3/8	1-1/8	17	.058	1.009	1/16	1/8	1/2
HT-134E	3/8	1-1/8	16	.065	.995	1/16	1/8	1/2
HT-140E	3/8	1.163	1 EMT	.057	1.049	1/16	1/8	1/2
HT-142	1/2	1-1/4	20	.035	1.180	1/16	1/8	9/16
HT-144	1/2	1-1/4	16	.065	1.120	1/16	1/8	1/2
HT-150	1/2	1.315	1 Pipe	.133	1.049	1/16	1/8	9/16



CRP

Stainless Steel Roller Stub Shafts

Available for use in blind hole bearings. Our standard parts are 1/2 inch dia. and are available in two lengths, 3/4 inch and 1-1/2 inch. A 7/16 inch hex section is provided on the outside portion so that an open end wrench may be used to tighten the pin against the conveyor frame using a 5/16 inch UNC bolt.

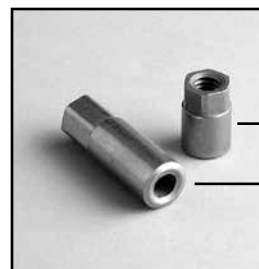
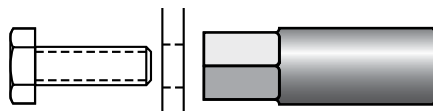

CRP-0812SS (HP version)

CRP-0824SS (HL version)

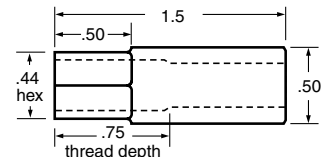
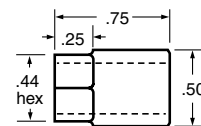

Machined Roller End Bearings



HR

Standard Duty Bearings

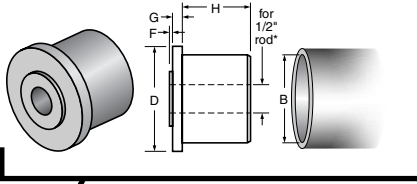

HP

Blind Hole Bearings

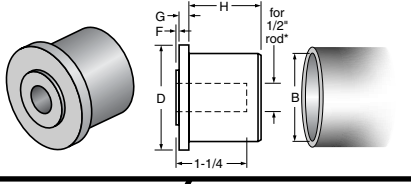

HL

Blind Hole Bearings, Long

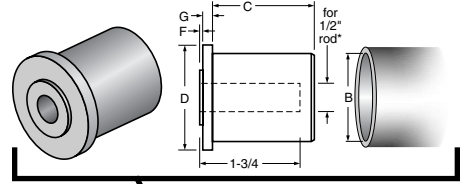

Part Number	Part Number	H
HR-163		1
HR-164		1
HR-174	HP-174	1-1/4
HR-175	HP-175	1-1/4
HR-180		1-1/4
HR-190		1-1/4
HR-200		1-1/4
HR-204	HP-204	1-1/4
HR-214		1-1/4
HR-220	HP-220	1-1/4
HR-224		1-1/4
HR-233		1-1/4
HR-234	HP-234	1-1/4
HR-235		1-1/4
HR-236		1-1/4
HR-238		1-1/4
HR-250		1-1/4
HR-255		1-1/4
HR-256		1-1/4
HR-258		1-1/4
HR-264		1-1/4
HR-270	HP-270	1-1/4
HR-280		1-1/4
HR-284		1-1/4
HR-285		1-1/4
HR-288		1-1/4
HR-320		1-1/4
HR-334	HP-334	1-3/8
HR-338		1-3/8

Tube OD D	Tube Gauge	Tube Wall	Tube ID B	F	G
1-3/8	18	.049	1.277	1/16	3/16
1-3/8	16	.065	1.245	1/16	3/16
1-1/2	18	.049	1.402	1/16	3/16
1-1/2	16	.065	1.370	1/16	3/16
1-1/2	14	.083	1.334	1/16	3/16
1.510	1-1/4 EMT	.065	1.380	1/16	3/16
1-5/8	16	.065	1.495	1/16	3/16
1.660	1-1/4 Pipe	.140	1.380	1/16	3/16
1.740	1-1/2 EMT	.065	1.610	1/16	3/16
1-3/4	16	.065	1.620	1/16	3/16
1-3/4	14	.083	1.584	1/16	3/16
1-3/4	11	.120	1.510	1/16	3/16
1-7/8	16	.065	1.745	1/16	3/16
1-7/8	13	.095	1.685	1/16	3/16
1.900	1-1/2 Pipe	.145	1.610	1/16	3/16
1.900	16	.065	1.770	1/16	3/16
2	18	.049	1.902	1/8	1/4
2	16	.065	1.870	1/8	1/4
2	14	.083	1.834	1/8	1/4
2	13	.095	1.810	1/8	1/4
2	11	0.12	1.760	1/8	1/4
2.197	2 EMT	0.065	2.067	1/8	1/4
2-1/4	2-1/4 Nolu	.154	1.942	1/8	1/4
2-1/4	18	.049	2.152	1/8	1/4
2-1/4	16	.065	2.120	1/8	1/4
2-1/4	14	.083	2.084	1/8	1/4
2-1/4	13	.095	2.060	1/8	1/4
2-1/4	11	.120	2.010	1/8	1/4
2-1/4	10	.134	1.982	1/8	1/4
2-3/8	16	.065	2.245	1/8	1/4
2-3/8	13	.095	2.185	1/8	1/4
2-3/8	11	.120	2.135	1/8	1/4
2.375	2 Pipe	.154	2.067	1/8	1/4
2-1/2	2-1/2 Nolu	.154	2.192	1/8	1/4
2-1/2	18	.049	2.402	1/8	1/4
2-1/2	16	.065	2.370	1/8	1/4
2-1/2	14	.083	2.334	1/8	1/4
2-1/2	13	.095	2.310	1/8	1/4
2-1/2	11	.120	2.260	1/8	1/4
2-1/2	10	.134	2.232	1/8	1/4
2-3/4	16	.065	2.620	1/8	1/4
2-3/4	13	.095	2.560	1/8	1/4
2-3/4	11	.120	2.510	1/8	1/4
2.875	2-1/2 Pipe	.203	2.469	1/8	1/4
3	18	.049	2.902	1/8	1/4
3	16	.065	2.870	1/8	1/4
3	14	.083	2.834	1/8	1/4
3	13	.095	2.810	1/8	1/4
3	11	.120	2.760	1/8	1/4

Part Number	C
HL-174	1-7/8
HL-204	1-7/8
HL-220	1-7/8
HL-233	1-3/4
HL-234	1-3/4
HL-255	1-3/4
HL-270	1-3/4

Molded Roller End Bearings



Ideal for dry conditions and lighter loads!

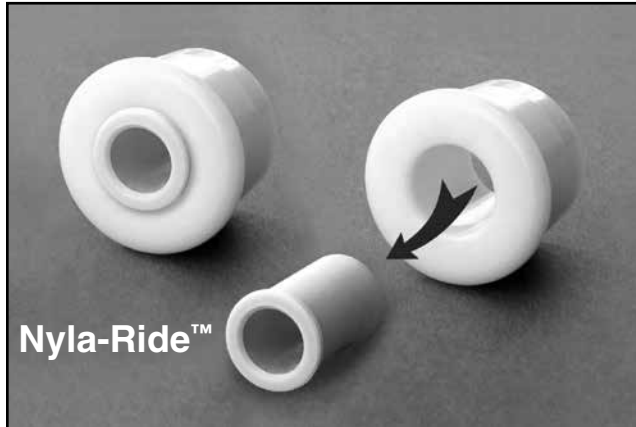

Nyla-Ride™

Nyla-Ride™ is a new lubricated nylon material that combines the strength properties of nylon with a lower coefficient of friction.

Thru Bore

Part Number	Roller OD	A Tube ID	B Bore Dia.	C	Tube Name
NT4-R220	1.9	1.61	1/2	.19	1-1/2" sch. 40 pipe
NT4.5-R220	1.9	1.61	9/16	.19	1-1/2" sch. 40 pipe
NT5-R220	1.9	1.61	5/8	.19	1-1/2" sch. 40 pipe
NT4-R221	1.9	1.5	1/2	.16	1-1/2" sch. 80 pipe
NT5-R221	1.9	1.5	5/8	.16	1-1/2" sch. 80 pipe
NT5-R250	2-1/4	1.94	5/8	.19	2-1/4" exact pipe
NT4-R270	2-3/8	2.07	1/2	.19	2" sch. 40 pipe
NT4.5-R270	2-3/8	2.07	9/16	.19	2" sch. 40 pipe
NT5-R270	2-3/8	2.07	5/8	.19	2" sch. 40 pipe
NT4-R271	2-3/8	1.94	1/2	.16	2" sch. 80 pipe
NT4.5-R271	2-3/8	1.94	9/16	.16	2" sch. 80 pipe
NT5-R271	2-3/8	1.94	5/8	.16	2" sch. 80 pipe
NT4-R280	2-1/2	2.20	1/2	.19	2-1/4" sch. 40 pipe
NT5-R280	2-1/2	2.20	5/8	.19	2-1/4" sch. 40 pipe
NT4-R320	2-7/8	2.47	1/2	.19	2-1/2" sch. 40 pipe
NT4.5-R320	2-7/8	2.47	9/16	.19	2-1/2" sch. 40 pipe
NT5-R320	2-7/8	2.47	5/8	.19	2-1/2" sch. 40 pipe

NT, NB

ABS End Cap with Nyla-Ride™ Bearing Insert

Used to fill the ends of the larger PVC tube sizes so that a small inexpensive flanged bearing can be used. Parts are available for five standard PVC conveyor roller sizes from 1.90" to 2-7/8" dia.



1/2" .50

1/4" pipe .54

5/8 .625

Shaft sizes available

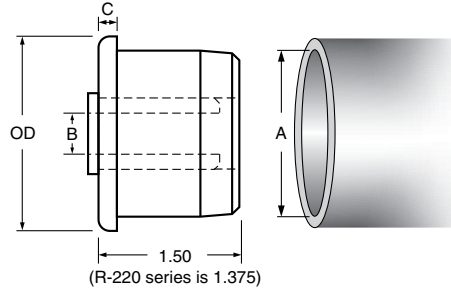

Blind Bore

Part Number	Roller OD	A Tube ID	B Bore Dia.	C	Tube Name
NB4-R220	1.9	1.61	1/2	.19	1-1/2" sch. 40 pipe
NB4.5-R220	1.9	1.61	9/16	.19	1-1/2" sch. 40 pipe
NB5-R220	1.9	1.61	5/8	.19	1-1/2" sch. 40 pipe
NB4-R221	1.9	1.5	1/2	.16	1-1/2" sch. 80 pipe
NB5-R221	1.9	1.5	5/8	.16	1-1/2" sch. 80 pipe
NB4-R270	2-3/8	2.07	1/2	.19	2" sch. 40 pipe
NB4.5-R270	2-3/8	2.07	9/16	.19	2" sch. 40 pipe
NB4-R271	2-3/8	1.94	1/2	.16	2" sch. 80 pipe
NB5-R271	2-3/8	1.94	5/8	.16	2" sch. 80 pipe
NB4-R280	2-1/2	2.20	1/2	.19	2-1/4" sch. 40 pipe
NB4-R320	2-7/8	2.47	1/2	.19	2-1/2" sch. 40 pipe
NB5-R320	2-7/8	2.47	5/8	.19	2-1/2" sch. 40 pipe

Color Coded inserts for easy bore size identification!

Nyla-Ride™ Bearing Insert

Through bore. Used with ABS end cap.

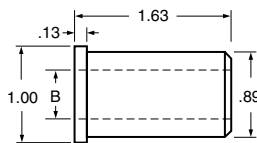

Part Number	Color	B (Bore Dia.)
NT-4	Orange	1/2
NT-4.5	Green	9/16
NT-5	Blue	5/8

Nyla-Ride™ Bearing Insert

Blind bore. Used with ABS end cap.

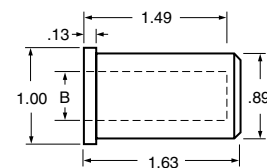

Part Number	Color	B (Bore Dia.)
NB-4	Orange	1/2
NB-4.5	Green	9/16
NB-5	Blue	5/8

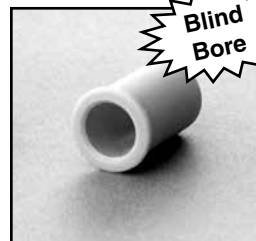

Conveyor Rollers



Premium low friction bearing material!

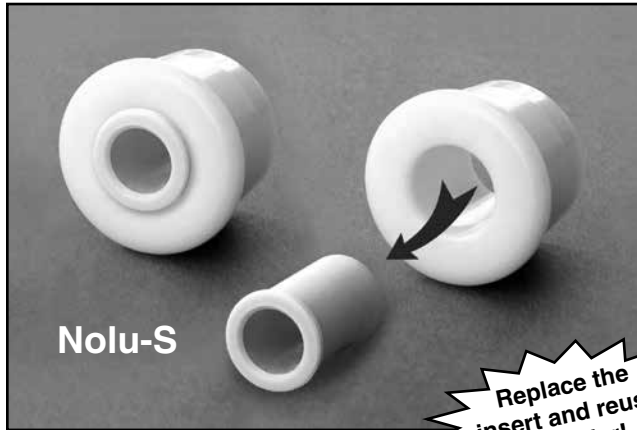

Nolu-S

Replace the insert and reuse the roller!

ST, SB

Friction Reducing Nolu-S!!

ABS End Cap with Nolu-S Bearing Insert

Used to fill the ends of the larger PVC tube sizes so that a small inexpensive flanged bearing can be used. Parts are available for five standard PVC conveyor roller sizes from 1.90" to 2-7/8" dia.

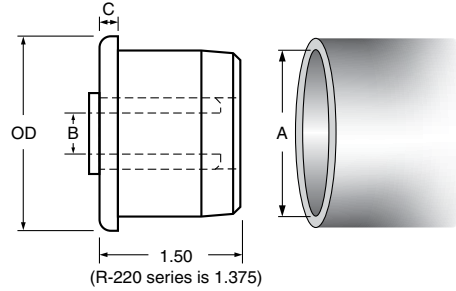

1/2" .50

1/4" pipe .54

5/8 .625

Shaft sizes available

Thru Bore

Part Number	Roller OD	A Tube ID	B Bore Dia.	C	Tube Name
ST4-R220	1.9	1.61	1/2	.19	1-1/2" sch. 40 pipe
ST4.5-R220	1.9	1.61	9/16	.19	1-1/2" sch. 40 pipe
ST5-R220	1.9	1.61	5/8	.19	1-1/2" sch. 40 pipe
ST4-R221	1.9	1.5	1/2	.16	1-1/2" sch. 80 pipe
ST4.5-R221	1.9	1.5	9/16	.16	1-1/2" sch. 80 pipe
ST5-R221	1.9	1.5	5/8	.16	1-1/2" sch. 80 pipe
ST4-R250	2-1/4	1.94	1/2	.19	2-1/4" exact pipe
ST5-R250	2-1/4	1.94	5/8	.19	2-1/4" exact pipe
ST4-R270	2-3/8	2.07	1/2	.19	2" sch. 40 pipe
ST4.5-R270	2-3/8	2.07	9/16	.19	2" sch. 40 pipe
ST5-R270	2-3/8	2.07	5/8	.19	2" sch. 40 pipe
ST5-R271	2-3/8	1.94	5/8	.16	2" sch. 80 pipe
ST5-R280	2-1/2	2.20	5/8	.19	2-1/4" sch. 40 pipe
ST4-R320	2-7/8	2.47	1/2	.19	2-1/2" sch. 40 pipe
ST5-R320	2-7/8	2.47	5/8	.19	2-1/2" sch. 40 pipe

Blind Bore

Part Number	Roller OD	A Tube ID	B Bore Dia.	C	Tube Name
SB4-R220	1.9	1.61	1/2	.19	1-1/2" sch. 40 pipe
SB4.5-R220	1.9	1.61	9/16	.19	1-1/2" sch. 40 pipe
SB5-R220	1.9	1.61	5/8	.19	1-1/2" sch. 40 pipe
SB4-R221	1.9	1.5	1/2	.16	1-1/2" sch. 80 pipe
SB4-R250	2-1/4	1.94	1/2	.19	2-1/4" exact pipe
SB4-R270	2-3/8	2.07	1/2	.19	2" sch. 40 pipe
SB4-R271	2-3/8	1.94	1/2	.16	2" sch. 80 pipe
SB4.5-R271	2-3/8	1.94	9/16	.16	2" sch. 80 pipe
SB4-R320	2-7/8	2.47	1/2	.19	2-1/2" sch. 40 pipe
SB4.5-R320	2-7/8	2.47	9/16	.19	2-1/2" sch. 40 pipe

Nolu-S Bearing Insert
Through bore. Used with ABS end cap.

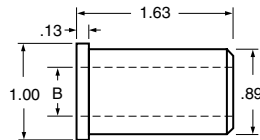

Part Number	B (Bore Dia.)
ST-4	1/2
ST-4.5	9/16
ST-5	5/8

Nolu-S Bearing Insert
Blind bore. Used with ABS end cap.

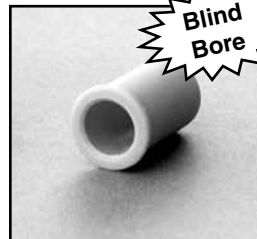
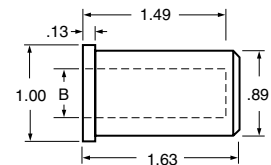

Part Number	B (Bore Dia.)
SB-4	1/2
SB-4.5	9/16
SB-5	5/8

Conveyor Rollers

Roller Components



CR4

Round Roller Shafts

Female threads on both ends.

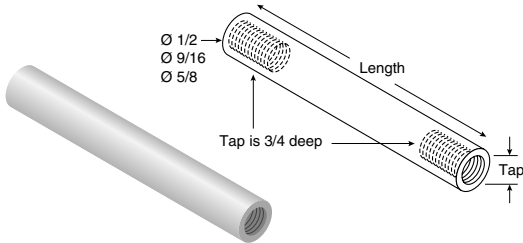

Material: 303 stainless steel.

Ø 1/2" Part Number	Length	Tap
VF-CR4-SS-0325-516	3.50	5/16-18
VF-CR4-SS-0325-38	3.50	3/8-16
VF-CR4-SS-0400-516	4.25	5/16-18
VF-CR4-SS-0400-38	4.25	3/8-16
VF-CR4-SS-0450-516	4.75	5/16-18
VF-CR4-SS-0450-38	4.75	3/8-16
VF-CR4-SS-0600-516	6.25	5/16-18
VF-CR4-SS-0600-38	6.25	3/8-16
VF-CR4-SS-0750-516	7.75	5/16-18
VF-CR4-SS-0750-38	7.75	3/8-16

Ø 9/16" Part Number	Length	Tap
VF-CR4.5-SS-0450-38	4.75	3/8-16
VF-CR4.5-SS-0600-38	6.25	3/8-16

Ø 5/8" Part Number	Length	Tap
VF-CR5-SS-0325-38	3.50	3/8-16
VF-CR5-SS-0400-38	4.25	3/8-16
VF-CR5-SS-0450-38	4.75	3/8-16
VF-CR5-SS-0600-38	6.25	3/8-16
VF-CR5-SS-0750-38	7.75	3/8-16

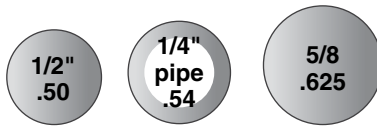

Shaft sizes available

CRP

Stainless Steel Roller Stub Shaft

For use in blind hole bearings. Stub shaft is 1/2 inch dia. and an 1-1/2 inch in length. A 7/16 inch hex section is provided on the outside portion so that an open end wrench may be used to tighten the pin against the conveyor frame using a 5/16 inch UNC bolt.

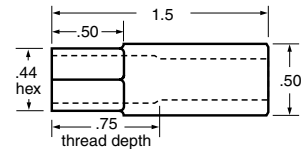
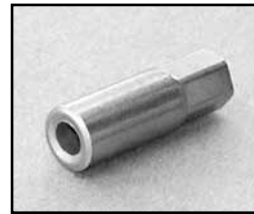

CRP-0824SS

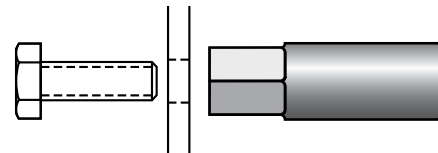

HXA

Steel Hex Shaft Adapters

Used to slip over hex shafting so that the outside diameter of the adapter becomes a journal surface on which the bearing in the roller can rotate. Parts are available in both carbon and 316 stainless steel.

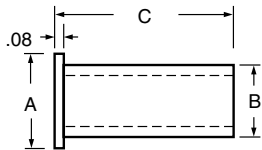
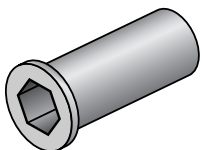

Part Number	Material	Hex Shaft	A Dia.	B Dia.	C Length
HXA-522SS	stainless steel	5/16"	3/4"	0.565	1-3/8"
HXA-722	steel	7/16"	13/16"	0.628	1-3/8"
HXA-732	steel	7/16"	13/16"	0.628	2"
HXA-732SS	stainless steel	7/16"	13/16"	0.628	2"
HXA-1132	steel	11/16"	1-1/8"	0.94	2"
HXA-1132SS	stainless steel	11/16"	1-1/8"	0.94	2"

FF-166

ABS Shaft Caps

Used on the ends of 7/16" hex or round shafts. They provide a simple method of retaining the shaft in the roller assembly. Primarily they are designed to offer a means of mounting the roller in the side frames, in a way that metal to metal contact can be avoided. With an 11/16" wide, open ended slot in the side frame, wear and noise can be eliminated.

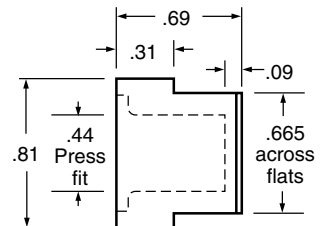
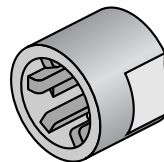

Conveyor Rollers



NBB

Plastic Ball Bearings

Designed for use with Nolu PVC tubing. Standard bearings use high performance Acetal Races and 420 stainless alloy balls. The same bearings are available with Polypropylene races and 316 stainless steel balls for use in highly corrosive environments such as battery manufacturing plants. However, custom made bearings can be designed to meet your needs.

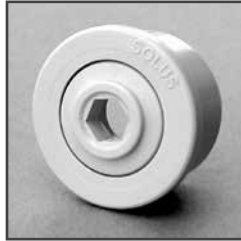

Part Number	Material	B Dia.	C	D Dia.	E	F	A Shaft
NBB-110	Acetal	.63	.125	.81	.06	.625	1/4" dia.
NBB-130	Acetal	.83	.10	1.06	.12	.625	5/16" hex
NBB-145	Acetal	1.03	.125	1.18	.118	.729	5/16" dia.
NBB-150	Acetal	1.06	.125	1.31	.187	.750	5/16" hex
NBB-220	Acetal	1.62	.12	1.90	.185	.935	7/16" hex
SPB-220	Polypropylene	1.62	.12	1.90	.185	.935	7/16" hex

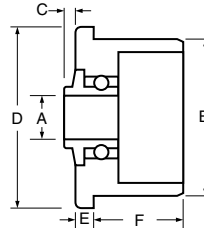

LSB

Labyrinth Sealed Ball Bearings

Designed for use with carbon or stainless steel tubing. These bearing assemblies are created using a unique 3 piece housing which makes it extremely difficult for contaminants to reach the core bearing. These roll end bearings can be ordered with a variety of bearing inserts.

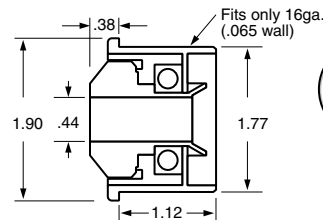

Part Number	Description	Shaft Size
222LSB-224-02	HDPE housing with carbon steel double shielded bearing insert	7/16
222LSB-224-03	HDPE housing with carbon steel double rubber sealed bearing insert	7/16

SBR

Stub Shaft Ball Bearings

Designed for use in light duty gravity applications. The stainless steel stub shafts are spring loaded to ease the assembly into a frame which has been threaded to accept the M8 roller shaft threads. Acetal housing.

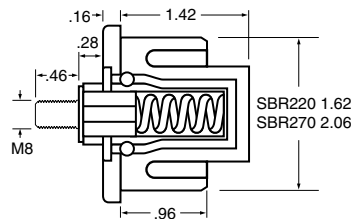

Part Number	OD
SBR-220	1.90"
SBR-270	2.37"

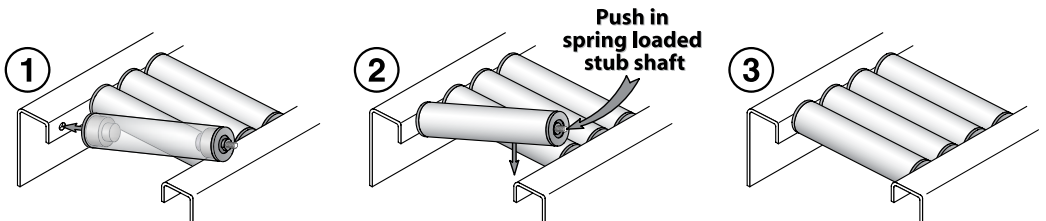

HPR

High Performance Ball Bearings

Designed for use with Nolu PVC tubing. These bearings are fitted with a special polypropylene housing assembly incorporating a high performance, shielded 6000 series ball bearing. This bearing is ideal for continuous use in driven systems and the precision bearing can also be used in gravity applications.

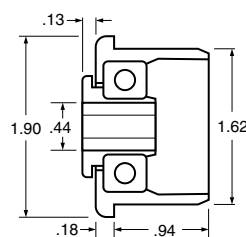

Part Number	Shaft Size
HPR-220	7/16"

Conveyor Rollers

Roller End Bearings



VRE

Roller Ends

Easily assembled onto any lengths of pipe. Fast installation. Quiet, sanitary operation. Glue fit assembly into 1-1/2 inch schedule 40 PVC pipe. Thru shaft bore.

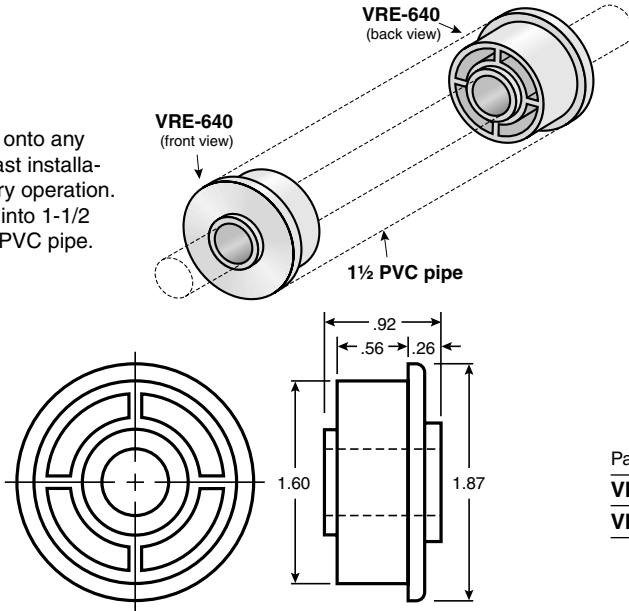

Part Number	Shaft	Tube Name
VRE-640-1540-12	1/2	1-1/2" sch. 40 PVC pipe
VRE-640-1540-58	5/8	1-1/2" sch. 40 PVC pipe

NRB

Acetal End Bearings

Inexpensive, injection molded conveyor roll bearings designed for light duty applications. However, with a 7/16" hex shaft, a low cost, higher performance roller can be produced by combining the Acetal bearing with a Nolu-S Hex Adapter. These Acetal bearings are available with various bore sizes and fit our most popular PVC tubing sizes.

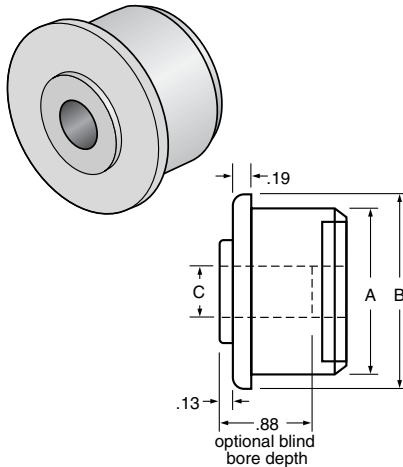

Part Number	C Dia.	A Dia.	B Dia.	Tube Name
NRB-220/5	5/16	1.62	1.90	1-1/2" sch. 40 pipe
NRB-220/8	1/2	1.62	1.90	1-1/2" sch. 40 pipe
NRB-220/8B*	1/2	1.62	1.90	1-1/2" sch. 40 pipe
NRB-220/9	9/16	1.62	1.90	1-1/2" sch. 40 pipe
NRB-220/10	5/8	1.62	1.90	1-1/2" sch. 40 pipe
NRB-270/8	1/2	2.09	2.37	2" sch. 40 pipe
NRB-270/8B*	1/2	2.09	2.37	2" sch. 40 pipe
NRB-270/10	5/8	2.09	2.37	2" sch. 40 pipe

*Blind bore

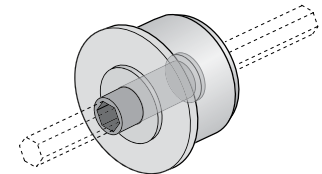

Nolu-S Rod

Nolu-S Rod

Nolu-S material and its outstanding characteristics; low friction, higher speed capability, self lubrication, is available in bulk extruded rod form. These rods are ideal for machining various types of plastic components including roller end bearings.

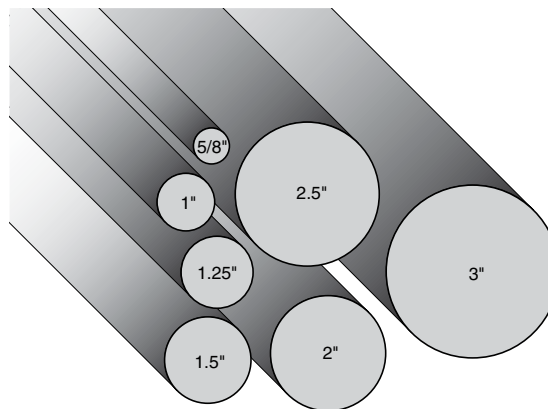

Part Number	Diameter (in.)	Length (ft.)
012R10A-5	5/8	5
012R16A-5	1	5
012R20A-5	1-1/4	5
012R24A-5	1-1/2	5
012R32A-5	2	5
012R40A-5	2-1/2	5
012R48A-5	3	5
012R10A-10	5/8	10
012R16A-10	1	10
012R20A-10	1-1/4	10
012R24A-10	1-1/2	10
012R32A-10	2	10
012R40A-10	2-1/2	10
012R48A-10	3	10

Conveyor Rollers



Sleeve Bearings or Ball Bearings?

Bearing selection is the key to improved conveyor roller performance and the elimination of downtime. Bearing performance depends not only on the use of an engineered bearing material, but also on the material selected for the mating surface.

Sleeve Bearing Types

Nolu-S Plastic Sleeve Bearings

Nolu-S is a proprietary alloy of food grade lubricants combined with UHMW. This creates a material which retains most of the properties of UHMW while significantly reducing friction. Nolu-S advantages include protection of expensive mating surfaces, lower noise and FDA and USDA approved ingredients. These bearings are used in the highest performance units produced by System Plast.

Nyla-Ride™ Bearing Inserts

Nyla-Ride™ is a new lubricated nylon material that combines the strength properties of nylon with a lower coefficient of friction. Color coding easily identifies the bore size.

UHMW Plastic Sleeve Bearings

The most abrasion resistant plastic ever developed. At slow speeds these bearings provide wear resistance where there is a high concentration of abrasive particles. However, as the conveyor speed increases, Nolu-S bearings must be used to reduce friction and wear.

Nolu Acetal Plastic Bearing

Inexpensive, injection molded conveyor roll bearings designed for light duty applications. However, with a 7/16" hex shaft, a low cost, higher performance roller can be produced by combining the Acetal bearing with a Nolu-S Hex Adapter. These Acetal bearings are available with various bore sizes and fit our most popular PVC tubing sizes.

Ball Bearing Types

Nolu Plastic Ball Bearings

Designed for use with the Nolu PVC tubing. Standard bearings use high performance Acetal Races and 420 stainless alloy balls. The same bearings are available with Polypropylene races and 316 stainless steel balls for use in highly corrosive environments such as battery manufacturing plants. However, custom made bearings can be designed to meet your needs.

LSB Ball Bearing

Designed for use with 1.9 diameter, 16 gauge tubing. This revolutionary three piece housing design makes it increasingly difficult for abrasives and contaminants to reach the bearing insert. A variety of 6000 Series inserts can be provided.

HPR-220 Nolu High Performance Ball Bearings

A special high performance ball bearing assembly designed to be used in many demanding applications. This bearing assembly consists of a high performance 6000 Series shielded ball bearing encased in a reinforced Polypropylene housing. This configuration provides the lowest coefficient of friction, excellent load capacity, and high speed capabilities. It is available to fit our most popular PVC size and comes standard with a 7/16" hex bore.

Roller Tubes

High Impact PVC Tube

Available in nine standard diameters ranging from 13/16" to 2-7/8" dia. The recommended load capacity at room temperature is shown in chart #1, the service temperature range being between -10°F and +140°F.

Steel Reinforcing Tube

Used to increase the stiffness of the above PVC tubing by a factor of 10. This tube is made of carbon steel and therefore must be encapsulated by using blind hole bearings if corrosion is anticipated. The recommended capacity of our standard PVC rollers should never be exceeded (max. 200lbs./roller).

Roller Components

ABS Plastic End Plug

Used to fill the ends of the larger PVC tube sizes so that a small inexpensive flanged bearing can be used. Parts are available for five standard PVC conveyor roller sizes from 1.90" to 2-7/8" dia.

Steel Hex Adapters

Used to slip over hex shafting so that the outside diameter of the adapter becomes a journal surface on which the bearing in the roller can rotate. Parts are available for 5/16" hex, 7/16" hex and 11/16" hex assemblies in both carbon and 316 stainless steel.

Nolu-S Plastic Hex Adapters

Also used to slip over 7/16" hex shafting. They are primarily designed for use with Nolu Acetal plastic bearings. In use, an oil film is generated at the bearing surface which reduces friction and wear. The service temperature range is normally between -10°F and +140° F. Steel hex adapters should be used where there is a high concentration of abrasive particles.

Stainless Steel Roller Stub Shafts

Available for use in blind hole bearings. Our standard parts are Ø1/2" and are available in two lengths, 3/4" and 1-1/2". A 7/16" hex section is provided on the outside portion so that a "C" wrench may be used to tighten the pin against the conveyor frame using a 5/16" UNC bolt.

ABS Plastic Shaft Caps

Used on the ends of 7/16" hex or round shafts. They provide a simple method of retaining the shaft in the roller assembly. Primarily they are designed to offer a means of mounting the roller in the side frames in a way that metal to metal contact can be avoided. With an 11/16" wide, open ended slot in the side frame, noise and frame wear can be eliminated.

UHMW Sprockets

Available to custom fit our standard rollers to a driven system. These UHMW sprockets are problem solvers in dirty or corrosive environments. They extend the life of the chain and are much quieter.



Roller Capacity

A roller should be selected which will provide maximum rigidity within normal design limitations. Choose the largest diameter possible and keep the length to a minimum. This will minimize deflection in the roller and transmit more even loading to the bearings. However, many bearing failures can be attributed, in part, to design loads which were based solely on the strength

of the tube stock without regard for bearing capacity. The recommended maximum roller load capacity is the lower of the two readings from Chart #1 and Chart #2. Nolu produces a steel reinforced version of these rollers which will increase the capacity from Chart #1 by a factor of 10. Nolu PVC rollers can be designed to carry up to 200 lbs.

Chart #1

This chart shows the load capacity of our High-Impact PVC Tubing

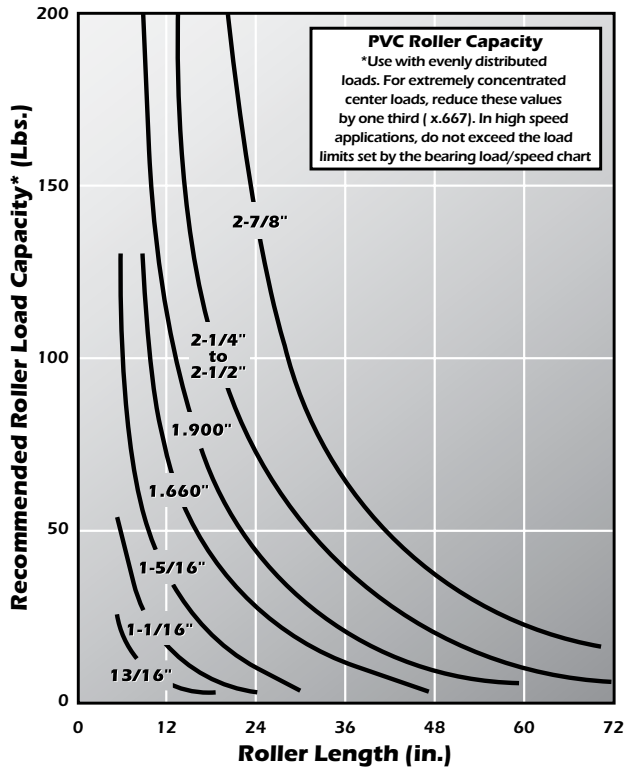
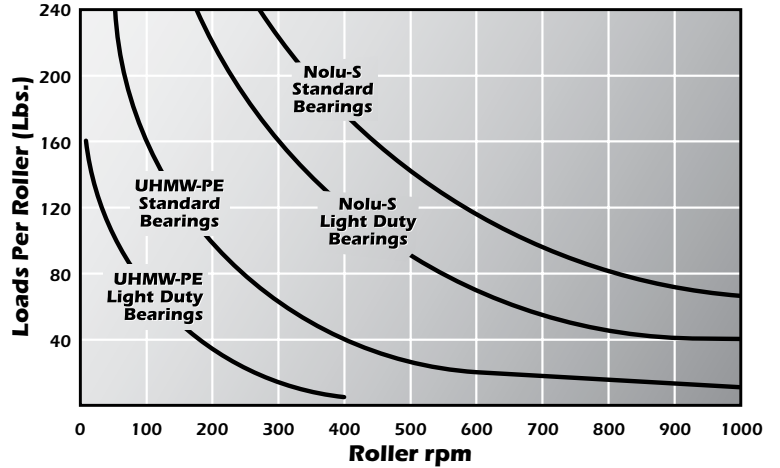

Chart #2

This chart identifies the performance limitations of our high performance sleeve bearings



Bearing Service Life

Surface Speed (feet per minute)	Radial Load (lbs. per roller)			Static Load Capacity
	5	10	15	
30	58,000 hours	29,000 hours	23,000 hours	45 lbs.
60	29,000 hours	14,000 hours	11,000 hours	45 lbs.
100	17,000 hours	8,000 hours	7,000 hours	45 lbs.

Table #1

Estimated average bearing life for Nolu plastic ball bearings in a clean environment. Bearing life will be reduced by impact loads and by exposure to contamination. With longer rollers the load capacity may be limited to the rigidity of the PVC tube, see chart #1 above.



SYSTEM PLAST™

Custom Plastics

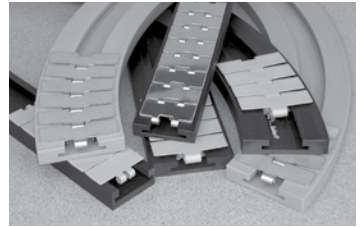

Premium Plastic
Fabrication Page **416**

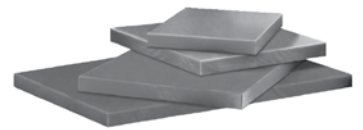

Engineered Plastic
Materials Page **418**

MACHINED PLASTICS & TECHNICAL INFORMATION

Section 10

Material Physical
Properties Page **421**

Chemical
Resistance Page **422**

Index Page **425**

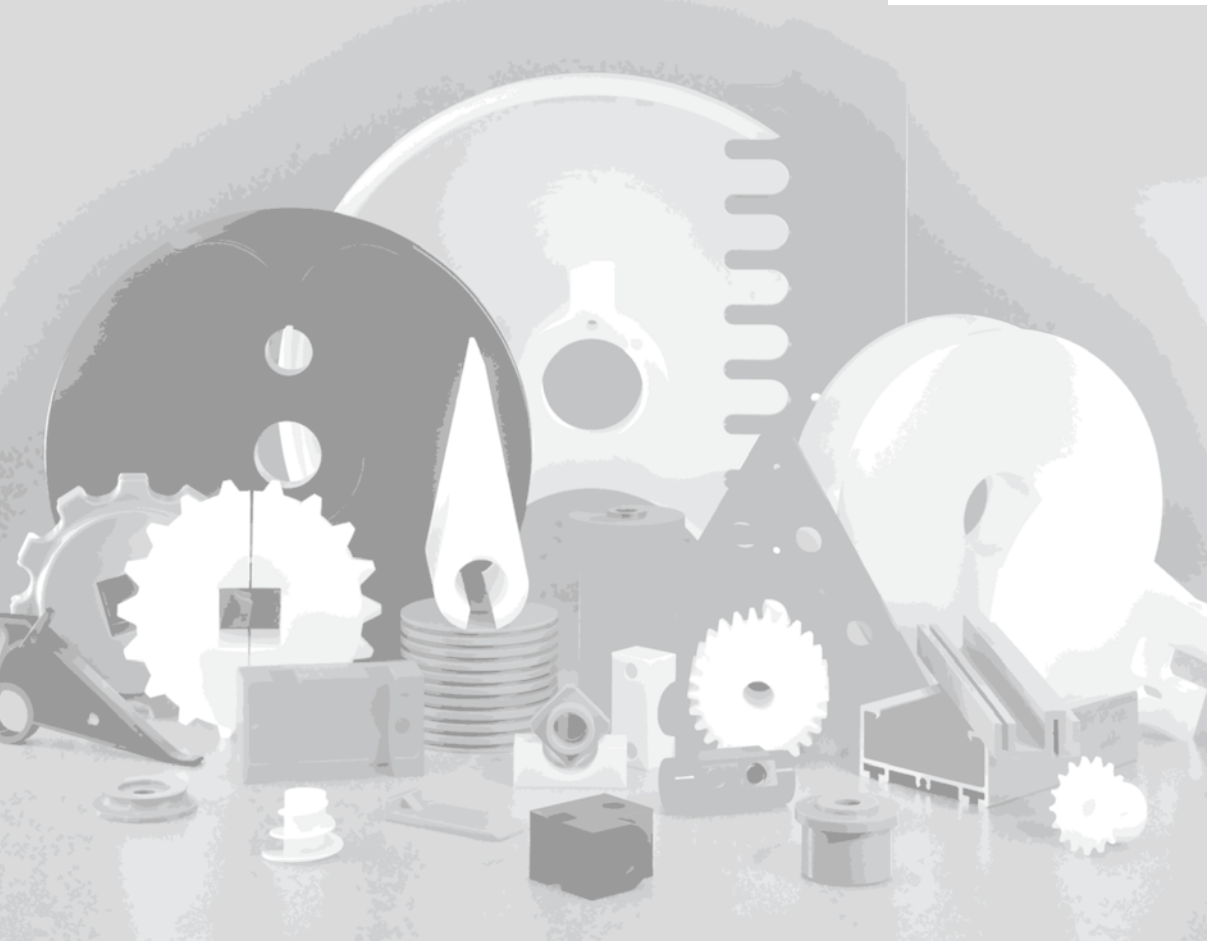

Plastic Design and Manufacturing

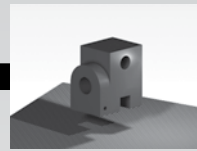
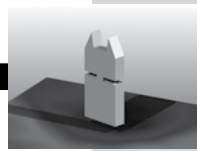
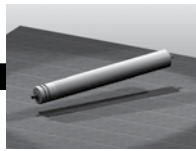
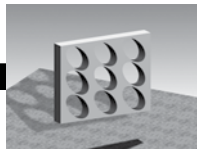
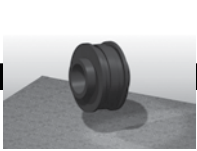

We put our leadership on the line for you.

When you're looking for a high quality, wear resistant plastic product, look to System Plast™. Our full line of products combines stainless steel, aluminum and engineered plastics to achieve reliability, superior performance and a compactness of design.

As one of the world's leading processors of precision engineered plastics, System Plast has a tradition of innovation and quality. Our components have become the standard of quality and performance in a wide range of industries, including conveyor manufacturing, materials handling, power transmission, packaging, and many more.



In addition to manufacturing excellence, System Plast has earned a reputation for out-standing customer service, offering a full range of design, custom fabrication, and support services. We look forward to hearing from you.

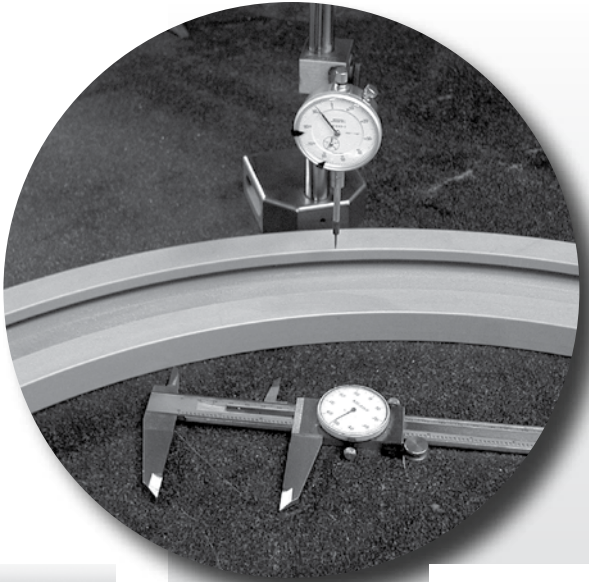

Engineering:

The department of infinite possibilities.

Customers around the world know that the shortest distance between a problem and a solution is to call the System Plast™ Engineering Department. We have the knowledge and experience to take your “wish list” and turn it into an effective product design. One that will solve your problem in the most effective and cost-efficient way possible.

After all, this is the same engineering department that holds patents for such innovations as Nolu-S, an internally-lubricated UHMW. And, it is the originator of many components that have now become industry standards.

System Plast engineers use the latest in design technologies. These advanced systems allow us to develop and modify designs quickly and cost-efficiently. And, they enable our engineers to quickly transmit designs to and from customers.

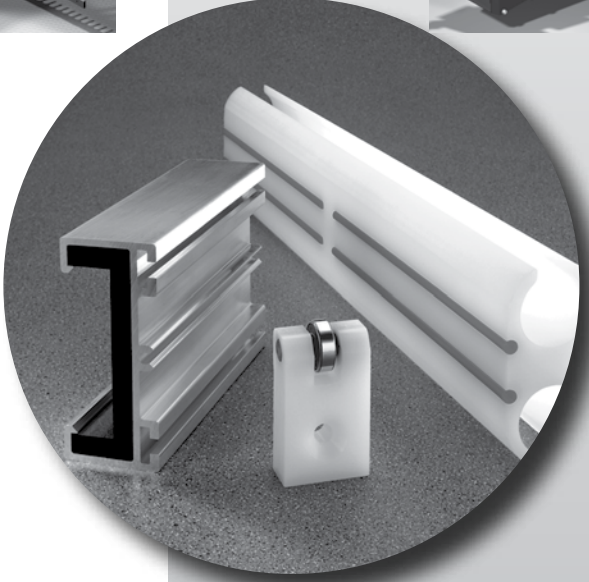
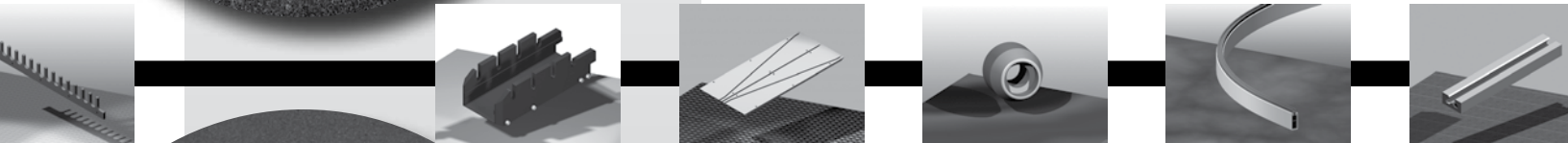

Production:

Achieving precision.

It's often very easy to tell System Plast parts from competitive products. Because our parts are smooth, well-finished, and free of burrs and seam lines. This is a reflection of the intense devotion to detail that marks every aspect of our production capabilities.

System Plast operates some of the industry's most advanced and versatile production facilities. A unique combination of computer controlled machinery and experienced operators provide the ability to turn out virtually any component, in any quantity.

Our precision fabrication capabilities include:

- Turning
- Milling
- Shaping and Sawing
- Planning
- Punch Press
- Drill Press
- Hot Stamping
- Roll Forming
- Tool & Die Shop
- Reverse Engineering



Quality and Service:

Your expectation, our standard.

Customers expect the best from System Plast. We're committed to delivering nothing less. In every phase of our operation, from design, to production, to quality assurance, we are committed to complying with your stringent quality standards.

Our quality processes begin with complete training of all personnel in the principles of total quality manufacturing techniques. Because the best time to control quality is at the very start. Then, we verify quality at every step, through in-process inspections and bar coding, followed by final inspections by full-time quality control specialists.

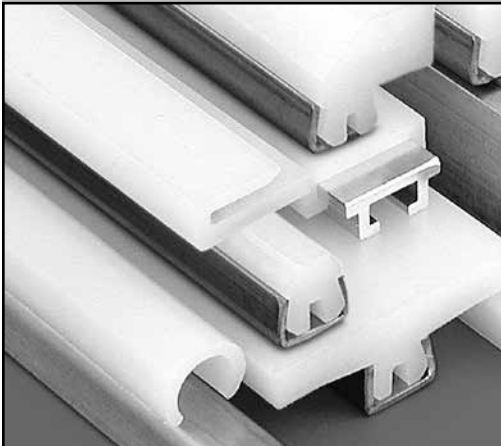

Material name: **UHMW-PE Natural** white

This bright white, ultra high molecular weight material is the choice for a wide variety of applications. The low friction characteristics of UHMW allow containers to move at high speed with minimum drag, container damage, and noise. The result is a material of higher wear resistance, which is color stable, and of uniform consistency. The value added material meets FDA (Food and Drug Administration) specification. CFR 177. 1520.1

Features:

- Extruded or machined
- Wide selection of shapes
- Extended coil lengths of various shapes available
- Smooth surface

Benefits:

- Low friction
- High wear resistance
- Higher temperature resistance



Material name: **Nolu-BR** black, **Nolu-GR** green

Nolu-BR is a proprietary blend of UHMW resins that is popular for use in conveyor chain tracks. Nolu-BR or GR maintains excellent chemical and corrosion resistance, while providing low friction, superior rigidity, and resistance to wear.

Features:

- Machined
- Popular conveyor chain solid track material

Benefits:

- High wear and abrasion resistance
- Economic material
- Chemical resistant



Material name: **Nolu-S** grey

Nolu-S is a blend of UHMW and other dry lubricants that maintain good wear characteristics while significantly reducing coefficients of friction. Its unique self-lubricating properties make it ideal for applications requiring reduced friction, noise reduction, and higher dry-running speeds.

Features:

- Extruded or machined
- Very low coefficient of friction - promotes material flow
- High-impact strength
- Chemical resistant with minimal moisture absorption
- FDA & USDA approved ingredients
- Noise suppressant
- Easy to machine – most general power tools are sufficient

Benefits:

- Extends the life of mating surfaces
- Lowers mating surface scratching or damage
- Reduces energy consumption
- Minimizes product pulsation on conveyors
- Low noise operation

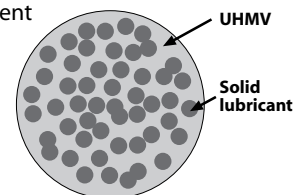

Engineered Plastic Materials

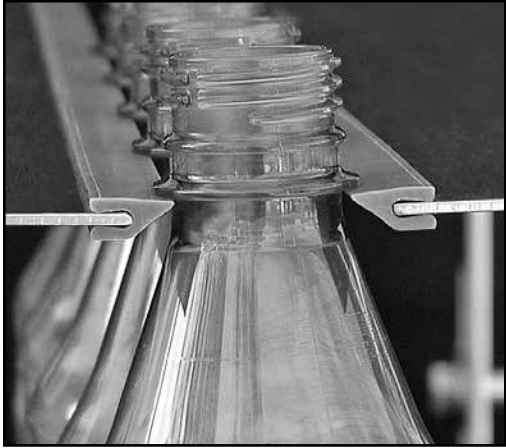

Material name: **Nolu-SR** dark grey

Nolu-SR features a much harder, longer wearing composition which is used in most high speed / high load applications. Nolu-SR helps guide PET containers in high speed, air conveying applications. It is the material of choice, proven to increase throughput, reduces jam ups and extend product life. Nolu-SR chain tracks offer the ultimate in UHMW wear resistance combined with low friction properties. Nolu-SR, in specific applications, is used as a superior alternative to Nylatron.*

Features:

- Extruded or machined
- Superior wear resistance – greater than standard virgin or repro material
- Low coefficient of friction – promotes material flow
- High-impact strength
- Chemical resistant with minimal moisture absorption
- FDA & USDA approved ingredients
- Easy to machine – most general power tools are sufficient

Benefits:

- High wear resistance
- Lowers mating surface scratching or damage
- Reduces energy consumption
- Suitable for running dry at higher speed
- Extends the life of mating surfaces
- Reduces conveyor chain loads or damage
- Low noise operation
- Reduces product pulsation on conveyors

Nolu-SR versus Nylatron

Nolu-SR reduces chainpull and avoids problems of overload in curves.

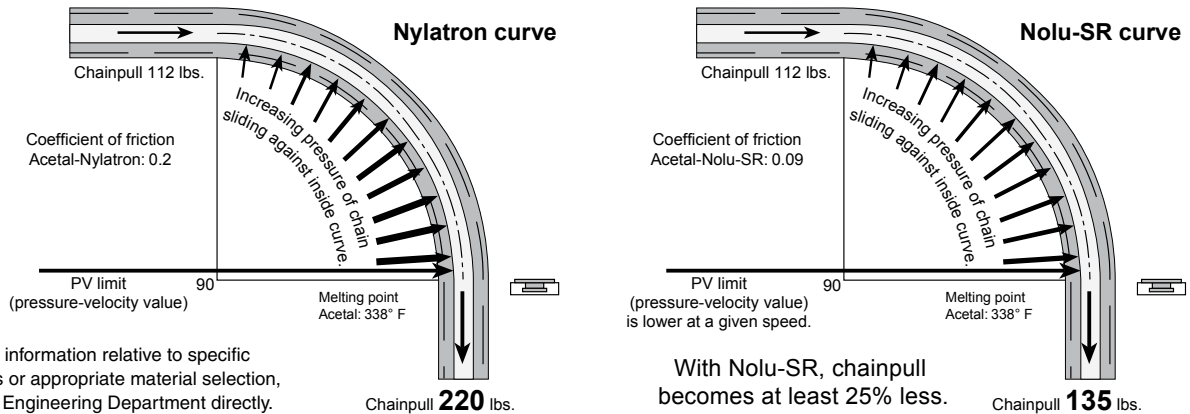

*For further information relative to specific applications or appropriate material selection, contact our Engineering Department directly.

Important notes about Nolu-S and Nolu-SR materials:

Storage:

Nolu-S and Nolu-SR should be stored at room temperature, or between the extremes of 40° F (5° C) and 95° F (35° C). This will help prevent premature aging of the material. Products made with Nolu-S and Nolu-SR should be stored in a manner to prevent distortion or warping over time due to heavy stacking pressure.

Extruded profiles stored in coils will have the tendency to retain a certain deformation when uncoiled, therefore consistency in the profile cross section over the full length of the coil cannot be guaranteed.

Nolu-S and Nolu-SR do not contain UV stabilizers, and should not be exposed to direct sunlight for extended periods of time.

Cleaning:

Regular cleaning intervals are recommended for Nolu-S and Nolu-SR. A solution mixture of warm water and commercially available soap-type agents with a pH value of 4.5 to 9.0 should be used. It is important to thoroughly rinse off any cleaning agent residue before reusing Nolu-S and Nolu-SR. Thermoplastics by nature have the tendency to develop some static charge over time. This causes the collection of dust particles and other ambient contaminants on thermoplastic materials. Cleaning all friction contact surfaces is recommended to obtain the best performance of Nolu-S and Nolu-SR.

	Specific Gravity	Tensile Strength	Tensile Modulus of Elasticity, 73°F	Elongation (at break), 73°F	Flexural Modulus of Elasticity, 73°F	Shear Strength	Compressive Strength	Coefficient of Friction (Dry vs Steel) Dynamic	Hardness, Rockwell, 73°F	Coefficient of Linear Thermal Expansion *	MIN. Continuous Service Temp In Air	MAX. Continuous Service Temp In Air	Water Absorption Immersion 24 Hours
	MECHANICAL						THERMAL						
Units	-	psi	psi	%	psi	psi	psi	-	-	in./in./°F	°F	°F	% by wt.
Test Method ASTM	D792	D638	D638	D638	D790	D732	D695	D1894	D785	D696	-	-	D570
Nolu-S	.94	2,800	90,000	360	100,000	2,900	3,000	0.06-0.12	R61	9-12 x 10 ⁻⁵	40	140	0.1
Nolu-SR	.94	3,100	100,000	150	110,000	3,100	3,300	0.06-0.13	R63	9-12.5 x 10 ⁻⁵	40	140	0.09

* For a 10 ft. length of extrusion, a temperature variation of 10° F would result in a deviation from the original length of approximately 0.1 to 0.15 inches.

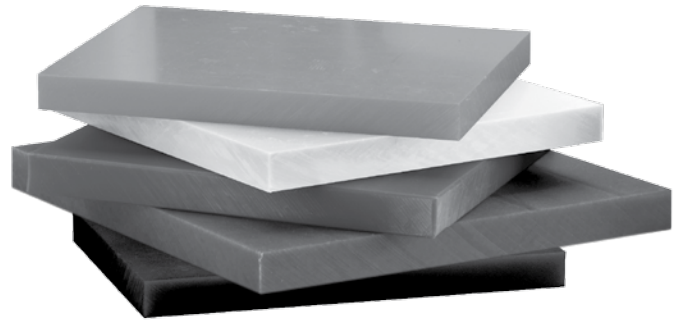

Sheets

Dimensions: 48 inches wide and 120 inches long.

Thickness tolerance: 0/+10%

Thickness	UHMW-PE Natural	Nolu-BR	Nolu-GR	Nolu-S	Nolu-SR
3/16	*	*	*	012S03B1	273S03B1
1/4	011S04B1	*	017S04B1	012S04B1	*
3/8	011S06B1	081S06B1	017S06B1	012S06B1	273S06B1
1/2	011S08B1	081S08B1	017S08B1	012S08B1	273S08B1
5/8	011S10B1	081S10B1	017S10B1	012S10B1	273S10B1
3/4	011S12B1	081S12B1	017S12B1	012S12B1	273S12B1
7/8	*	*	*	*	*
1	011S16B1	081S16B1	*	012S16B1	273S16B1
1-3/16	*	081S19B1	*	012S19B1	273S19B1
1-1/4	011S20B1	081S20B1	*	012S20B1	*
1-3/8	*	081S22B1	*	012S22B1	*
1-1/2	011S24B1	081S24B1	*	012S24B1	*
1-3/4	*	081S28B1	*	012S28B1	*
2	011S32B1	*	*	012S32B1	*
2-1/2	011S40B1	*	*	012S40B1	*
2-3/4	*	*	*	*	*
3	*	*	*	012S48B1	*

*On request and for adequate quantities these sheets can be produced

Physical Properties for Guide Rail and Materials

	Specific Gravity	Tensile Strength	Tensile Modulus of Elasticity, 73°F	Elongation (at break), 73°F	Flexural Modulus of Elasticity, 73°F	Shear Strength	Compressive Strength	Coefficient of Friction (Dry vs Steel) Dynamic	Hardness, Rockwell, 73°F	Tensile Impact, 73°F	Coefficient of Linear Thermal Expansion	Melting Point	MIN. Continuous Service Temp In Air	MAX. Continuous Service Temp In Air	Water Absorption Immersion 24 Hours	Water Absorption Saturation	Effect of sunlight
	MECHANICAL										THERMAL						
Units	-	psi	psi	%	psi	psi	psi	-	-	ft. lb./in ²	in./in./°F	°F	°F	°F	% by wt.	-	-
Test Method ASTM	D792	D638	D638	D638	D790	D732	D695	D1894	D785	D1822	D696	D789	-	-	D570	D570	-
UHMW-PE	0.93	3,000	100,000	350	100,000	3,300	3,400	0.09-0.15	R64	1,000	9-12 x 10 ⁻⁵	280-289	-40	160-180	0	-	**
Nolu-BR, GR	.93	3,100	110,000	200	110,000	3,500	3,600	0.09-0.15	R68	-	9-12 x 10 ⁻⁵	280-300	-40	160-180	0	-	**
Nolu-S	.94	2,800	90,000	360	100,000	2,900	3,000	0.06-0.12	R61	-	9-12 x 10 ⁻⁵	-	40*	140	0.1	-	Acceptable
Nolu-SR	.94	3,100	100,000	150	110,000	3,100	3,300	0.06-0.13	R63	-	9-12 x 10 ⁻⁵	280-300	40*	140	0.09	-	Acceptable
Nylon 6/6 (Polyamide)	1.14-1.18	10,000-14,000	250,000-400,000	20-200	175,000-410,000	9,600	5,000	0.17-0.25	R110-120	90-180	4-6 x 10 ⁻⁵	482-500	+14	180-200	0.5-1.4	6-8	**
Acetal	1.41	8,800-11,000	400,000-450,000	30	375,000-450,000	8,000-9,000	15,000-16,000	.25	R120-122	90	4.5-6 x 10 ⁻⁵	335-347	-40	180	0.22-0.25	0.90	Limited
Teflon blend (hi-temp material)	2.1-2.2	1,500-3,000	50,000-90,000	100-200	90,000-110,000	-	-	0.04-0.10	R10-20	30-200	5.5-8 x 10 ⁻⁵	612-630	-400	500	0.1	-	**
Polypropylene	0.9	4,300-5,000	160,000-250,000	100-600	200,000	-	6,500	-	R94	-	5.8-10.2 x 10 ⁻⁵	327	-40	212	0.1	<0.1	**

* Application conditions such as variations in temperature, humidity, particulates, load, speed, etc., determine the appropriate value. Please contact the System Plast engineering department to discuss specific requirements.

** Requires addition of UV stabilizer. Contact System Plast for further information.

Note: These are typical values intended for reference and comparison purposes only.

Valu Guide vs. half round

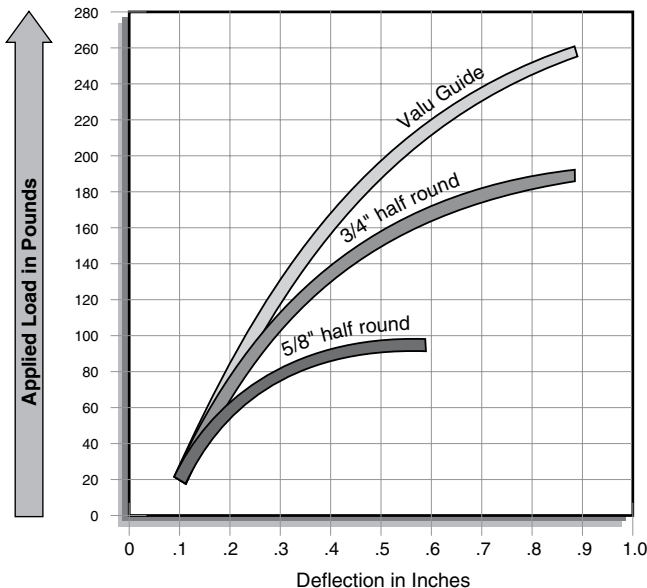

Valu Guide vs. half round

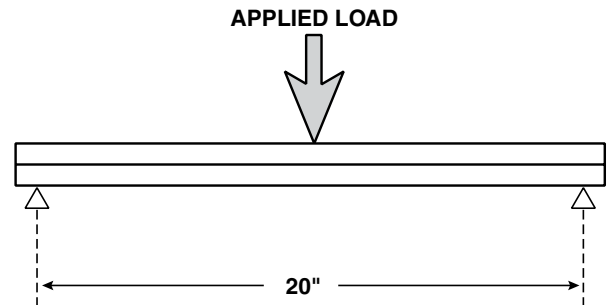

Moment of inertia:

$$I_{xx} = 0.0062 \text{ in}^4$$

$$I_{yy} = 0.0027 \text{ in}^4$$

Material:

Sheath = 304 stainless steel

Insert = UHMW

Valu Guide was proven stronger in test performed by an independent testing lab in Anaheim, CA.

Ref. "National Testing Standards" Report No. 12718

The information listed herein is stated to the best of our knowledge and is intended to provide a general guideline for the materials and its uses. The values given are based on laboratory testing backed with global industry experience. All properties in these tables have performed equal or better in laboratory testing. However, the data should not be considered as guaranteed specific properties. Suggested applications are provided for information only and are not specific recommendations.

Chemical Resistance

The following chemicals and fluids are known to attack or be compatible with the materials shown below as supplied by System Plast. The degree of compatibility is shown by a code letter which indicates the effect of the chemical at room temperature. We must emphasize that this chart should be used only as a general guide. If more information or clarification is required, please contact System Plast.

A = No attack, possibly slight absorption. Negligible effect on mechanical properties.
 B = Slight attack by absorption. Some swelling and a small reduction of mechanical properties likely.
 C = Moderate attack or appreciable absorption. Material will have a limited life.
 D = Material will decompose or dissolve in a short time.
 - = No data available.

Where aqueous solutions are shown the concentration as a weight percentage is given.

Aq. = Aqueous Solution
 Sat. = Saturated Aqueous Solution
 Conc. = Concentrated Aqueous Solution

This information, based on experience, is in line with accepted engineering practice and is believed to be reliable. However, we do not warrant the conformity of our materials to the listed properties or the suitability of our materials for a particular purpose.

Chemical	Concentration %	Polyamide (Nylon)	Acetal	UHMW	PTFE (Hi-Temp)	Polypropylene	Neoprene Rubber
Acetaldehyde Aq.	40	B	A	A	A	A	C
Acetamide Aq.	50	A	-	-	A	A	A
Acetic Acid Aq.	10	C	C	A	A	A	D
Acetone		A	B	A	A	A	D
Acrylonitrile		A	-	-	A	A	D
Alcohols, Aliphatic		A	A	A	A	A	-
Allyl Chloride		C	-	A	A	A	-
Allyl Alcohol		A	-	A	A	A	-
Aluminum Chloride	10	-	-	A	A	A	A
Aluminum Sulfate	10	-	-	A	A	A	A
Ammonia Aq.	10	A	D	A	A	A	A
Ammonia Gas		B	-	A	A	A	A
Ammonium Carbonate Aq.	10	A	-	A	A	A	A
Ammonium Chloride Aq.	10	A	-	A	A	A	A
	37	A	-	A	A	A	-
Amyl Acetate		A	-	A	A	A	D
Amyl Alcohol		A	-	A	A	A	B
Aniline		C	A	A	A	A	D
Antimony Trichloride Aq.	10	C	-	A	A	A	-
Barium Chloride Aq.	10	A	-	A	A	A	A
Barium Sulfate Aq.	10	A	-	A	A	A	-
Barium Sulfide Aq.	10	A	-	A	A	A	A
Benzaldehyde		B	-	A	A	A	D
Benzene		A	A	B	A	C	D
Benzene Sulfonic Acid		D	-	A	A	C	B
Benzyl Alcohol		C	-	A	A	C	B
Benzoic Acid Aq.	Sat.	C	-	A	A	A	D
Beverages Aq., Alcoholic		B	-	A	A	A	-
Beverages, Carbonated		B	-	A	A	A	-
Bitumen		B	-	A	A	A	-
Bleaching Lye	10	B	-	A	A	A	-
	100	B	C	A	A	A	-

Chemical	Concentration %	Polyamide (Nylon)	Acetal	UHMW	PTFE (Hi-Temp)	Polypropylene	Neoprene Rubber
Boric Acid Aq.	10	A	-	A	A	A	A
Bromine Aq.	30	D	-	-	-	-	D
Bromine Liquid		D	-	-	-	-	D
Butanol		B	-	A	A	A	A
Butyl Acetate		B	-	A	A	A	D
Butyl Phthalate		A	-	A	A	A	-
Butylene Glycol		A	-	A	A	A	-
Butylamine		-	C	-	A	-	D
Butyric Acid Aq.	20	B	-	A	A	A	D
Butyric Acid	Conc	B	-	A	A	A	D
Butyrolactone		A	-	-	A	-	-
Calcium Chloride Aq.	10	B	-	A	A	A	A
Calcium Hypochlorite		D	-	A	A	A	B
Camphor		A	A	A	A	A	-
Carbon Disulfide		A	A	B	A	D	D
Carbon Tetrachloride		A	A	B	A	D	D
Carbonic Acid	10	A	A	A	A	A	A
Carnallite Aq.	10	A	-	A	A	A	-
Chloracetic Acid Aq.	10	C	-	-	A	A	-
Chloral Hydrate		C	-	A	A	A	-
Chlorine Aq.	10	C	-	B	A	A	D
Chlorine Gas	100	C	-	B	A	A	D
Chlorobenzene		A	-	B	A	A	D
Chloroform		C	-	B	A	C	D
Chlorosulfonic Acid Aq.	10	C	-	C	A	A	D
Chrome Alum Aq.	10	A	-	A	A	A	A
Chromic Acid Aq.	1	C	-	B	A	A	D
Citric Acid Aq.	10	C	A	A	A	A	A
	Sat.	C	-	A	A	A	-
Cresols		D	-	A	A	A	-
Cresylic Acid		D	-	-	A	A	D
Cupric Chloride Aq.	10	B	-	A	A	A	B

Chemical	Concentration %	Polyamide (Nylon)	Acetal	UHMW	PTFE (Hi-Temp)	Polypropylene	Neoprene Rubber
Cupric Sulfate Aq.	0.5	B	-	A	A	A	B
Cyclohexane		A	-	A	A	A	C
Cyclohexanol		B	-	A	A	A	B
Cyclohexanone		A	-	A	A	A	D
Decalin		A	-	A	A	A	D
Detergents, Organic		A	-	A	A	A	B
Dibutylphthalate		A	-	A	A	A	D
Dichlorodifluoro Methane		A	-	-	A	A	-
Dichloroethylene		A	-	C	A	A	-
Diethyleneglycol Aq.	90	A	-	A	A	A	A
Diesel Oil		A	-	A	A	A	C
Dimethyl Carbinol		B	A	A	A	A	-
Dimethyl Aniline		A	-	A	A	A	-
Dimethyl Formamide		A	A	A	A	A	D
Dietyl Phthalate		A	-	-	A	A	D
Dioxan		A	A	A	A	A	D
Edible Oils		A	A	A	A	A	-
Ethanol Aq.	96	B	A	A	A	A	A
Ether, Diethyl		A	A	A	A	A	C
Ethyl Acetate		A	B	A	A	A	D
Ethyl Butyrate		A	-	-	A	A	-
Ethyl Chloride		A	-	-	A	D	A
Ethylene Chlorhydrin		D	-	-	A	A	B
Ethylene Chloride		B	A	B	A	A	D
Ethylene Diamine		A	A	A	A	A	A
Ethylene Dichloride		B	-	-	A	A	D
Ethylene Glycol Aq.	96	B	-	A	A	A	A
Ethylene Propionate		A	-	-	A	A	-
Ferrous Chloride Aq.	5	B	-	A	A	A	B
	10	C	-	A	A	A	B
Fluorine		D	-	C	C	A	-
Fluosilicic Acid Aq.	10	C	-	A	A	A	-

Chemical Resistance

Chemical	Concentration %	Material					
		Polyamide (Nylon)	Acetal	UHMW	PTFE (Hi-Temp)	Polypropylene	Neoprene Rubber
Fluothane		A	-	A	A	A	-
Freon 12		A	-	-	A	A	A
Formaldehyde Aq.	40	B	A	A	A	A	-
Formic Acid Aq.	3	B	D	A	A	A	-
	10	C	D	A	A	A	-
Fruit Juices	Conc	B	B	A	A	A	-
Furfural		A	-	A	A	A	D
Glycerine		A	-	A	A	A	A
Heptane		A	A	A	A	D	B
Hexane		A	A	A	A	A	B
Hydrobromic Acid Aq.	10	C	-	A	A	A	C
Hydrochloric Acid Aq.	0.4	B	D	A	A	A	B
	2	C	D	A	A	A	B
	10	D	D	A	A	C	C
Hydrofluoric Acid Aq.	4	C	D	A	B	A	A
Hydrogenated Veg. Oils		A	-	A	A	A	-
Hydrogen Peroxide	0.5	C	D	A	A	A	A
	1	C	D	A	A	A	A
	3	D	D	A	A	A	B
Hydrogen Sulfide Aq.	Sat.	A	C	A	A	A	B
Hydroquinone		B	-	-	A	A	D
Iodine		C	D	A	A	C	D
Isooctane		A	-	A	A	A	B
Isopropyl Alcohol		B	A	A	A	A	B
Isopropyl Ether		A	-	A	A	A	C
Lactic Acid Aq.	10	C	B	A	A	A	A
	90	D	-	A	A	A	A
Lead Acetate Aq.	10	B	-	A	A	A	B
Lead Stearate		A	A	A	A	A	-
Linseed Oil		A	A	A	A	A	C
Lubricating Oils, Petroleum		A	A	A	A	A	B
Lithium Bromide Aq.	50	D	-	-	A	A	-
Magnesium Chloride Aq.	10	A	A	A	A	A	A
Magnesium Hydroxide Aq.	10	A	A	A	A	A	B
Magnesium Sulfate Aq.	10	A	A	A	A	A	A
Maleic Acid Aq.	Conc	C	-	A	A	A	D
Malonic Acid Aq.	Conc	C	-	-	A	A	-
Manganese Sulfate Aq.	10	A	A	-	A	A	-
Mercuric Chloride Aq.	6	C	B	A	A	A	A
Methanol		B	A	A	A	A	A
Methyl Acetate		A	B	-	A	A	B
Methyl Ethyl Ketone		A	B	A	A	A	D
Methyl Pyrrolidone		A	-	-	A	D	-
Methyl Chloride		B	C	B	A	A	D
Methyl Phenyl Ether		A	-	-	A	A	-
Mineral Oils		A	A	A	A	A	B
Naphthalene		A	-	A	A	A	D
Nickel Sulfate Aq.	10	A	-	A	A	A	A

Chemical	Concentration %	Material					
		Polyamide (Nylon)	Acetal	UHMW	PTFE (Hi-Temp)	Polypropylene	Neoprene Rubber
Nitric Acid Aq.	0.1	C	D	A	A	A	D
	10	D	D	A	A	A	D
Nitrobenzene		C	B	A	A	A	D
Nitromethane		B	-	-	A	A	C
Oleic Acid		A	C	A	A	A	D
Oleum		D	D	C	A	A	D
Oxalic Acid Aq.	10	B	C	A	A	A	B
Ozone		C	C	B	A	A	-
Paraffin		A	A	A	A	A	C
Perchloroethylene		B	A	-	A	A	D
Perchloric Acid Aq.	10	C	C	A	A	C	B
Petrol (Gasoline)		A	A	A	A	C	D
Petroleum Ether		A	A	A	A	A	-
Phenol Aq.	6	C	D	A	A	A	C
	75	D	D	A	A	A	D
Phenol, molten		D	D	A	A	A	D
Phosphoric Acid Aq.	0.3	B	C	A	A	A	C
	3	C	C	A	A	A	D
	10	D	C	A	A	A	D
Phthalic Acid Aq.	Sat.	B	-	A	A	A	-
Potassium Acetate Aq.	50	A	A	A	A	A	B
Potassium Bicarb. Aq.	60	A	-	A	A	A	-
Potassium Bromide Aq.	10	A	-	A	A	A	-
Potassium Carbonate Aq.	60	A	-	A	A	A	-
Potassium Chloride Aq.	90	A	-	A	A	A	A
Potassium Dichromate Aq.	5	B	-	A	A	A	A
Potassium Ferrocyanide Aq.	30	A	-	-	A	A	-
Potassium Hydroxide Aq.	10	A	-	A	A	A	B
	50	C	-	A	B	A	B
Potassium Nitrate Aq.	10	A	B	A	A	A	A
Potassium Permanganate Aq.	1	C	A	A	A	A	-
Potassium Sulfate Aq.	Conc	A	-	A	A	A	A
Potassium Sulfide Aq.	90	A	-	-	A	A	A
Pyridine		A	A	A	A	A	D
Propane Gas		A	-	A	A	A	B
Resorcinol		C	-	-	A	A	-
Salicylic Acid		A	-	-	A	A	-
Silicone Fluids		A	A	A	A	A	A
Silver Nitrate		A	A	A	A	A	A
Soap Solutions		A	A	A	A	A	B
Sodium Acetate Aq.	60	B	-	A	A	A	B
Sodium Benzoate Aq.	10	A	-	A	A	A	-
Sodium Bicarbonate Aq.	50	A	A	A	A	A	A
Sodium Bisulfite Aq.	10	A	-	A	A	A	A
Sodium Bromide Aq.	10	A	-	-	A	A	-
Sodium Carbonate Aq.	20	A	A	A	A	A	A
	50	A	-	A	A	B	A
Sodium Chlorate Aq.	10	A	-	A	A	A	-

Chemical	Concentration %	Material					
		Polyamide (Nylon)	Acetal	UHMW	PTFE (Hi-Temp)	Polypropylene	Neoprene Rubber
Sodium Chloride Aq.	10	A	A	A	A	A	A
	90	A	A	A	A	A	-
Sodium Cyanide Aq.	10	A	A	A	A	A	A
Sodium Hydroxide Aq.	10	A	D	A	A	A	B
	50	A	D	A	B	A	-
Sodium Hypochlorite 15%		D	D	A	A	A	D
Sodium Nitrate Aq.	50	A	B	A	A	A	B
Sodium Perborate Aq.	10	B	-	A	A	A	B
Sodium Phosphate Aq.	90	A	-	-	A	A	B
Sodium Silicate		A	A	A	A	A	A
Sodium Sulfate Aq.	90	A	A	A	A	A	A
Sodium Sulfide Aq.	90	A	-	A	A	A	A
Sodium Thiosulfate Aq.	10	A	A	A	A	A	A
Stannic Chloride Aq.	10	C	-	-	A	A	D
Stannic Sulfate Aq.	10	C	-	-	A	A	-
Stearic Acid		A	-	A	A	A	B
Sulfur Dioxide (Dry Gas)	100	B	B	A	A	A	D
Sulfuric Acid Aq.	2	C	D	A	A	A	D
	5	D	D	A	A	C	-
Sulfurous Acid Aq.	10	D	C	A	A	A	B
Tallow		A	A	A	A	A	B
Tar		B	-	-	A	A	C
Tartaric Acid Aq.	10	B	-	A	A	A	A
Tetrachloroethylene		A	-	B	A	A	D
Tetrahydrofuran		A	A	B	A	A	D
Tetralin		A	-	A	A	A	D
Thionyl Chloride		C	B	C	A	A	-
Thiophene		A	-	B	A	A	-
Toluene		A	A	B	A	C	D
Trichloroethylene		B	B	B	A	A	D
Triethanolamine		A	-	A	A	A	B
Turpentine		A	A	A	A	A	D
Trisodium Phosphate Aq.	95	B	-	-	A	A	D
Urea		A	A	A	A	A	-
Vegetable Oils		A	A	A	A	A	C
Vinegar		C	C	A	A	A	B
Vinyl Chloride		A	-	-	A	A	-
Water		A	A	A	A	A	B
White Spirit		A	A	A	A	A	B
Wines & Spirits		B	A	A	A	A	A
Xylene		A	A	B	A	D	D
Xylenol		D	-	-	A	-	D
Zinc Chloride Aq.	10	B	-	A	A	A	A
Zinc Oxide		A	-	A	A	A	-
Zinc Sulfate Aq.	10	A	-	A	A	A	A

Chemical Resistance for Conveyor Chain Materials

☺ = Good resistance ☹ = Average resistance depending on conditions ☹ = Insufficient resistance (not recommended)

Chemical	Acetal Resin		PBT Polyester (NG)		400 series Stainless Steel		304 Stainless Steel		Chemical	Acetal Resin		PBT Polyester (NG)		400 series Stainless Steel		304 Stainless Steel	
	Conc.%	Result	Conc.%	Result	Conc.%	Result	Conc.%	Result		Conc.%	Result	Conc.%	Result	Conc.%	Result	Conc.%	Result
Acetic acid	5	☹	10	☹	5-50	☹	20	☹	Methylene chloride		☹		☹		☹		☹
Acetone		☹		☹		☹	25	☹	Milk		☹		-		☹		☹
Acrylonitrile	-	-	-	-	-	-	-	-	Mineral oil		☹		-		☹		☹
Aluminium chloride		☹		-		☹		☹	Nitric acid	5	☹		☹		☹	65	☹
Aluminium sulphate		☹		-		-		-	Nitrobenzene		☹		-		-		-
Amyl alcohol	-	-	-	-		☹		☹	Oleic acid		☹		-		☹		☹
Ammonia		☹	10	☹		☹	100	☹	Oxalic acid		☹		-	10	☹	65	☹
Ammonium chloride	-	-	-	-		☹		☹	Paraffin		☹		-		☹		-
Aniline	-	-	-	-		☹		☹	Petroleum		☹		☹		☹		☹
Barium chloride	-	-	-	-		-		☹	Petroleum ether		☹		-		-		☹
Beer		☹		☹		☹		☹	Phenol		☹		☹		☹		☹
Benzene		☹		-		☹	70	☹	Phosphoric acid	10	☹		-		☹	50	☹
Benzic acid	-	-	-	-		☹	100	☹	Potassium bichromate		-		-		-		-
Benzol		☹		-		☹		☹	Potassium bromide		-		-		-		-
Boric acid	-	-	-	-		☹		☹	Potassium hydroxide	25	☹	5	☹		☹		☹
Brine	-	-	-	-		☹		☹	Potassium permanganate		-		-		-		☹
Butter		☹		-		☹		☹	Sea water		☹		-		☹		☹
Butyl acetate	-	-	-	-		-		-	Silicone oil		-		☹		-		-
Butyl alcohol	-	-	-	-		☹		☹	Silver nitrate		-		-		☹		☹
Butyl glycole		☹	10	☹		-		-	Sodium carbonate		☹		-		☹	100	☹
Calcium chloride		☹		-		☹		☹	Sodium chloride		☹	5	☹		☹		☹
Carbon sulphide		☹		-		☹		☹	Sodium hydroxide		-		☹		☹		☹
Carbon tetrachloride		☹		-		☹	10	☹	Sodium hypochlorite		☹		-		☹		☹
Chlorine water		☹		☹		☹		☹	Sodium silicate		-		-		☹	100	☹
Chloroform		☹		-		☹		☹	Sodium sulphate		-		-		☹	100	☹
Chromic acid	-	-	-	-		☹	10	☹	Soft drinks		☹		☹		☹		☹
Citric acid		☹	10	☹		☹	25	☹	Suds		☹		☹		☹		☹
Cyclohexane	-	-	-	-		-		-	Sulphuric acid	40	☹	10	☹		☹		☹
Cyclohexanol	-	-	-	-		-		-	Tartaric acid	30	☹		-		☹	50	☹
Decalin	-	-	-	-		-		-	Tetrahydrofuran		-		-		-		-
Dioxane	-	-	-	-		-		-	Tetralin		-		-		-		☹
Distilled water		☹		-		☹		☹	Tincture of iodine		-		-		-		☹
Ethyl acetate	-	-		☹		☹		☹	Toluol		-		☹		☹		-
Ethyl alcohol		☹		☹		☹	10	☹	Transformer oil		-		-		-		-
Ethyl chloride	-	-	-	-		☹		☹	Trichloroethylene		-		-		☹		☹
Ethyl ether	-	-	-	-		☹		-	Triethanolamin		-		-		-		-
Ferric chloride	-	-	-	-		☹		☹	Turpentine		☹		☹		☹		☹
Food fats		☹		☹		☹		☹	Vaseline		-		-		☹		-
Food oils		☹		☹		☹		☹	Vegetable juice		☹		☹		☹		☹
Formaldehyde		☹		☹		☹	100	☹	Vegetable oils		☹		☹		☹		☹
Formic acid	10	☹		-		☹		☹	Vinegar		☹		-		☹		☹
Freon 12	-	-	-	-		☹		☹	Water and soap		☹		☹		☹		☹
Fresh water		☹		☹		☹		☹	Whisky		-		☹		☹		☹
Fruit juice		☹		☹		☹		☹	Wine		☹		☹		☹		☹
Gasoline	-	-	-	-		☹		☹	Xylol		☹		-		☹		☹
Glycerine		☹		-		☹		☹									
Hydrochloric acid	35	☹	10	☹		☹		☹									
Hydrofluoric acid	-	-	-	-		☹		☹									
Hydrogen peroxide	-	-	-	-		☹		☹									
Isopropyl alcohol	-	-		☹		☹		☹									
Lactic acid		☹		-		☹		☹									
Linseed oil		☹		-		☹		☹									
Magnesium chloride	-	-	-	-		☹		☹									
Methyl acetate	-	-	-	-		-		☹									
Methyl alcohol		☹		☹		☹	80	☹									

Data shown in this table was taken from laboratory tests performed on unstrained samples and are merely indicative. Chemical resistance under normal working conditions can depend on various factors, such as stress and temperature, concentration of the chemical agent and duration of its effects.

Product Description Index

- 1400 Chain Series, 59
1700 Chain Series, 54
1701 Chain Series, 56
1702 Chain Series, 54
1843 Chain Series, 50
1863 Chain Series, 51
1873 Chain Series, 46, 52
2121 Belt Series, 76, 78
2250 Chain-Belt Series, 82, 84
2251 Chain-Belt Series, 94, 96, 98
2252 Belt Series, 88, 90, 92
2260 Chain-Belt Series, 86
600 Chain Series, 58
812 Chain Series, 8
815 Chain Series, 8
820 Chain Series, 16
821 Chain Series, 22
828 Chain Series, 20
831 Chain Series, 18, 36
843 Chain Series, 48
863 Chain Series, 49
878 Chain Series, 24, 38, 44
879 Chain Series, 26, 28, 30, 40
880 Chain Series, 26, 28, 30
881 Chain Series, 10, 12, 14
881O Chain Series, 10, 12
882 Chain Series, 32, 34, 42
Accessory Holder, 332-333, 336, 338
Adjustable Glides, 368
Adjustable Clamp, 231
Adjustable Levelers, 344-368
Adjustable Support Bar, 324
Adjusting Rods, 230, 279, 296-297
Aluminum Guide Rail, 247, 257-261
Bar Caps, 242-245
Bars Covers, 255-256
BeadRail™, 275
BeadWall™, 280-281
Bearings, Roller, 406-409
Belt Side Guide, 188
Belt Support Wear Strip, 176-181, 188
Bipod Base, 373-374
Bolt Slot Cover, 284
Bottle Guides, 247
Bottle Indicator, 335
Braced Angle Bracket, 283
Brackets, 289-324
Cable Guides, 194-195
Cable Pulleys, 193-194
Case/Crate Conveyor Chains, 58-59
Chain Guide Shoe, 182-183
Chain Guide, 206-207
Chain Guide Wear Strip, 180-182
Chain Return Shoe, 187
Channel Clamps, 182
Chemical Resistance, 422-424
Clamp and Metal Rod, 227, 237
Combiner Bracket, 283
Combiner Section Ends, 283
Connecting Joints, 371
Corner Block, 219
Corner Clip, 284
Cross Blocks, 327-331, 338
Cross Clamp, 333
Double Rail Clamps, 225-226, 236
Drip Pan Holders, 326
Drive Rivet, 185
DynaPlate, 156-158
Extended Chain Guide, 191, 207
Fixed Bracket, 324-325
Flat Top Belts, 76-79, 88-93
Flat Top Belts with Rollers, 80-81, 94-95
Flat Top Chains Belts, 84-87, 96-99
Flexible Roller Guides, 276-279
Flight Edging, 263
Guide Rail, 200-217
Half Round Bar Covers, 253
Half Round Bars, 253
Hand Knobs, 307
Handles, 380
Hanger Bearings, 264
Heavy Duty BeadWall™, 281
Heavy Duty Brackets, 291
Heavy Duty Clips, 232
Heavy Duty Combiner Bracket, 283
Hinges, 381-382
Hi-Temp Rail, 213
Idler Wheels, 104-105
J-Leg, 248-251
Jointed Adjusting Rods, 229, 297
Jointed SpeedSet Rod Adapter, 303
Lane Divider Bracket, 284
Lane Divider, 216-217, 279
LBP 2120 belt series, 80
LBP 821 chain series, 60
LBP 831 chain series, 64
LBP 878 chain series, 72
LBP 882 chain series, 66, 68, 70
LBP 8257 chain series, 62
Leg Tie, 368
Levelers, 344-368
Locking Shaft Collars, 340
Machined Hub, 126
Magnetic Corner Track, 146-153
Magnetic Side Flexing Chains, 14-15, 30-31
Metal "L" Brackets, 321-322
Metal Levelers, 367
Modular Belts, 74
Modular Transfer Plates, 156-162
Mounting Bar, 228, 325
M-Profile, 276-278
Multiflex Chains, 54-57
Neck Guides, 246
Nolu-S Rod, 412
Nose Bar, 75
Nose Plow, 285
Nyla-Ride™, 408
Photocell Mounts, 334-335
Plastic "L" Brackets, 304-305
Plastic Double Rail Clamp, 226, 236
Plastic Fabrication, 415-419
Plastic Materials, 418-420
PolyGlide, 214-215
Post Brackets, 317-319
Post Caps, 369-370
Protective Caps, 325
Quick Adjust Head, 303
Rail Bender Rollers, 220-223
Rail Benders, 220, 222
Rail Bridge Kit, 233
Rail Clips/Clamps, 224-228
Rail Splice Clamp, 232-233
Ratchet Handles, 331, 376-379
Reflector Mount, 336, 338
Reflector Mounting Assembly, 337, 339
Return Rollers, 164-166, 386-388
Rod End, 229, 237, 412
Rod Mount Brackets, 308-309
Rod Mounts, 323
Roller Chain Break Tool, 53
Roller Chain Guide Assembly, 189-190
Roller Chain Guide, UHMW, 191-192
Roller Combiner, 282
Roller End Bearings, 406-412
Roller Module Clamp, 279
Roller Stub Shaft, 406
Rollers, 391-405
Rollers, Return, 164-168, 386-388
Roll-Tech, 384-385
Round Bar, 262
Round Bar Covers, 252
Round Rod and Clamps, 237
Safe Transfer Module, 154-155
Safety Cap, 325
Safety Handle, 380
SaniStar, 344-347
Sanitary Leg, 375
Self Tightening Clip, 234-235
Sensor Mount, 228, 331
Sensor Mounting Assembly, 337, 339
Serpentine Wear Strip, 187
Shaft Collar, 340
Side Flexing Chains, 10-13, 24-29, 32-35, 38-47, 50-53, 66-73
Side Guide, 240
Side Mounting Bracket, 370
Side Plow, 285
Side Transfer Shoes, 183
Single Rail Clamps, 224
Solid Guide Rail, 208-211
Spacers for Brackets, 306
SpeedRail™, 269-271, 274
SpeedRoll™, 271-273
SpeedSet Bracket, 298-303, 315-316
SpeedSet Cartridge, 320
SpeedSet Spacers, 300
Spiral Conveyor Wear Strips, 244, 254
Splice Clamp, 232
Splice Kits, 284
Splice Sleeve, 232
Splicing Pins, 270, 273
Sprockets for Belt Series 2121, 116-118
Sprockets for Belt Series 2252, 122-123
Sprockets for Belt Series LBP2120, 116-118
Sprockets for Belt Series LBP2251, 122-123
Sprockets for Case/Crate Chain Series 600, 125
Sprockets for Case/Crate Chain Series 1400, 124
Sprockets for Case/Crate Chain Series 1431, 124
Sprockets for Chain Series 812, 102-103
Sprockets for Chain Series 815, 102-103
Sprockets for Chain Series 815VG, 102-103
Sprockets for Chain Series 820, 108-109
Sprockets for Chain Series 821, 110-111
Sprockets for Chain Series 821VG, 110-111
Sprockets for Chain Series 828, 112-113
Sprockets for Chain Series 831, 108-109
Sprockets for Chain Series 831VG, 108-109
Sprockets for Chain Series 878TAB VG, 112-113
Sprockets for Chain Series 878TAB, 112-113, 126
Sprockets for Chain Series 878TGS, 112-113
Sprockets for Chain Series 879, 112-113
Sprockets for Chain Series 879M, 112-113
Sprockets for Chain Series 879TAB VG, 112-113
Sprockets for Chain Series 879TAB, 112-113
Sprockets for Chain Series 880, 112-113
Sprockets for Chain Series 880M, 112-113
Sprockets for Chain Series 880TAB, 112-113
Sprockets for Chain Series 881, 106-107
Sprockets for Chain Series 8810, 106-107
Sprockets for Chain Series 8810T, 106-107
Sprockets for Chain Series 881M, 102-103
Sprockets for Chain Series 881MO, 102-103
Sprockets for Chain Series 881T, 106-107
Sprockets for Chain Series 881TVG, 106-107
Sprockets for Chain Series 881VG, 106-107
Sprockets for Chain Series 882, 114-115
Sprockets for Chain Series 882M, 114-115
Sprockets for Chain Series 882T, 114-115
Sprockets for Chain Series 882TVG, 114-115
Sprockets for Chain Series LBP821, 110-111
Sprockets for Chain Series LBP831, 108-109
Sprockets for Chain Series LBP878T, 112-113
Sprockets for Chain Series LBP882T, 114-115
Sprockets for Chain Series 2250TAB, 120-121
Sprockets for Chain-Belt Series 2251TAB, 120-121
Sprockets for Chain-Belt Series 2260, 120-121
Sprockets for Multiflex Chain, 119, 125
Sprockets, 102-125
Stacking Ring, 306
Stainless Steel Brackets, 310-322
Stainless Steel Leveler, 344-349
Stainless Steel Rod, 227, 237
Standard Duty Bracket, 292-295
Static Dissipative Rail, 212
Straight Running Chains, 8-9, 16-23, 36-37, 48-49, 60-65
Support Bars, 324
Support Rods, 336, 338
Swivel Cap, 293
Swivel Clamp, 230
Tab Chain Guide, 178, 204
Tangential Sprocket, 126
T-Clamp, 336, 338
Tee Guide Rail, 176-180, 202-205, 210-211
T-head bolts, 284
Threaded End, 165, 431
Threaded Rod, 365
Triple Rail Clamp, 226
Tripod Base, 373-374
T-Rod, 332
Tube Cap, 343
Tube Covers, 254
Tube Ends, 342-343
Turning Disk, 129
Twist Insert, 219
UHMW and Aluminum Rails, 257-262
UHMW Tape Roll, 196
Universal Mount, 334
ValuFlex, 169-175
ValuTrac, 130-145
V-Belt Guide, 194
Vibration Pads, 363
Wear Bed Grid, 218
Wear Strip, UHMW, 184, 186-187, 252
Wide Guide™, 238-239

Part Number Index

011R..., 262	11072, 68	11383, 26	11536G, 52
011S..., 464	11073, 70	11386, 26	11537G, 52
012R..., 262	11074, 70	11388, 72	11538G, 52
012R..., 456	11075, 70	11389, 24	11539G, 52
012S..., 464	11076, 62	11390, 24	11540G, 52
017R..., 262	11077, 62	11391, 38	11541G, 52
017S..., 464	11078, 62	11395M, 30	11542G, 52
081S..., 464	11087, 59	11396M, 30	11543, 50
10001L, 8	11093, 42	11397MG, 30	11544G, 50
10003, 8	11094, 42	11398MG, 30	11545, 50
10004, 8	11095, 42	11404, 44	11546G, 50
10005, 8	11096, 59	11407, 44	11547, 51
10006, 8	11098, 59	11408, 44	11552G, 51
10007, 8	11100G, 16	11409, 44	11557, 51
10009L, 8	11102G, 16	11420G, 24	11562G, 51
10011, 8	11103G, 16	11421M, 30	11593, 48
10012, 8	11104G, 16	11429, 50	11594G, 48
10013, 8	11105G, 18	11430G, 50	11595G, 48
10014, 8	11106G, 18	11433, 50	11597, 48
10016, 8	11107G, 18	11434G, 50	11598G, 48
10018, 8	11130, 20	11459, 32	11599G, 48
10019, 8	11132G, 20	11460, 32	11607, 18
10020, 8	11134, 20	11461, 32	11608, 18
10021, 8	11151, 16	11462G, 32	11609, 18
10036L, 8	11154, 16	11463G, 32	11614, 48
10085L, 8	11155, 16	11464G, 32	11615, 48
10095L, 8	11156, 16	11480, 32	11616, 48
10107, 10	11160, 18	11481, 32	11617, 48
10108, 10	11161, 18	11482, 32	11622, 49
10109, 10	11162, 18	11483, 34	11623, 49
10110, 12	11170, 22	11484, 34	11624, 49
10111, 12	11171, 22	11485, 34	11625, 49
10112, 12	11172, 22	11486, 34	11633, 52
10201, 14	11185, 26	11500G, 28	11634, 52
10203, 14	11187, 26	11500MG, 30	11635, 52
10206L, 14	11193, 26	11501G, 28	11636, 52
10208L, 14	11194, 26	11501MG, 30	11637, 52
10213L, 14	11195, 28	11502G, 26	11638, 52
10255L, 14	11195M, 30	11503G, 26	11639, 52
10265L, 14	11197, 28	11504G, 28	11644, 48
10302, 8	11197M, 30	11505G, 28	11645, 48
10304, 8	11198, 28	11506, 26	11646, 48
10305, 8	11198M, 30	11507, 26	11647, 48
10306, 8	11199, 28	11508G, 26	11652, 49
10307, 8	11221, 36	11509G, 26	11653, 49
10400, 10	11242, 40	11510G, 22	11654, 49
10401, 10	11245, 40	11511G, 22	11655, 49
10402, 10	11322, 98	11512G, 22	11663, 52
10403, 12	11322XPG, 98	11513G, 34	11664, 52
10404, 12	11323, 82	11514G, 34	11665, 52
10405, 12	11323XPG, 82	11515G, 34	11666, 52
11002, 22	11324, 82	11516G, 34	11667, 52
11004, 22	11324XPG, 82	11517G, 48	11668, 52
11006, 22	11325, 96	11518G, 48	11689, 52
11007, 58	11325XPG, 96	11519G, 48	11706G, 52
11009, 58	11328, 98	11520G, 48	11708G, 52
11040, 34	11328XPG, 98	11521G, 48	11720, 48
11041, 34	11329, 86	11522G, 48	11721G, 48
11042, 34	11329XPG, 86	11523G, 49	11723, 48
11043, 34	11362, 16	11525G, 49	11724G, 48
11053, 64	11365, 16	11526G, 49	11730, 46
11054, 64	11368, 16	11527G, 49	11731, 46
11055, 60	11371, 16	11528G, 49	11732, 46
11056, 60	11374, 16	11529G, 49	11736, 44
11057, 60	11377, 28	11530G, 49	11737, 44
11068, 68	11377M, 30	11531G, 52	11738, 44
11069, 68	11377ST, 38	11532G, 52	11739, 44
11070, 66	11380, 28	11533G, 52	11740, 44, 46
11071, 66	11380M, 30	11534G, 52	11741, 46
	11380ST, 28	11535G, 52	11742, 44, 46

Part Number Index

11746, 44, 47	121330S, 110	12293S, 110	123117S, 121
11762, 46	121331S, 110	12294S, 110	123118S, 121
11763, 46	121332S, 110	12295S, 110	123119S, 121
11766, 46	121333S, 110	123000VS, 118	123120S, 121
11767, 46	121334S, 110	123001VS, 118	123122S, 121
11775, 46	121335S, 110	123002VS, 118	123123S, 121
11951, 54	121336S, 110	123003VS, 118	123124S, 121
11953, 54	121337S, 110	123004VS, 118	123125S, 121
11954, 54	121338S, 110	123005VS, 118	123126S, 121
11955, 54	121339S, 110	123007VS, 118	123127S, 121
11956, 56	121340S, 110	123009VS, 118	123128S, 121
11958, 56	121341S, 110	123010VS, 118	123129S, 121
121017, 120	121342S, 110	123011VS, 118	123130S, 121
121023, 120	121343S, 110	123012VS, 118	123131S, 121
121029, 120	121344S, 110	123013VS, 118	123132S, 121
121125, 108	121752S, 112	123058S, 123	123133S, 121
121126S, 108	121753S, 112	123059S, 123	123134S, 121
121127S, 108	121754S, 112	123060S, 123	123136S, 121
121128S, 108	121755S, 112	123061S, 123	123137S, 121
121129S, 108	121756S, 112	123062S, 123	123138S, 121
121147S, 108	121757S, 112	123063S, 123	123139S, 121
121148S, 108	121758S, 112	123064S, 123	123140S, 121
121149S, 108	121759S, 112	123066S, 123	123150S, 123
121150S, 108	121760S, 112	123067S, 123	123151S, 123
121151S, 108	121761S, 112	123068S, 123	123152S, 123
121152S, 108	121762S, 112	123069S, 123	123154S, 123
121153S, 108	121763S, 112	123070S, 123	123155S, 123
121154S, 108	121764S, 112	123071S, 123	123156S, 123
121155S, 108	121765S, 112	123072S, 123	123162S, 123
121156S, 108	121766S, 112	123073S, 123	123163S, 123
121157S, 108	121767S, 112	123074S, 123	123164S, 123
121159S, 108	121768S, 114	123075S, 123	123190VS, 118
121160S, 108	121769S, 114	123076S, 123	123191VS, 118
121161S, 108	121769SK, 114	123077S, 123	123192VS, 118
121162S, 108	121770S, 114	123078S, 123	123193VS, 118
121163S, 108	121771S, 114	123080S, 123	123194VS, 118
121164S, 108	121772S, 114	123081S, 123	123195VS, 118
121165S, 108	121772SK, 114	123082S, 123	123197VS, 118
121166S, 108	121773S, 114	123083S, 123	123198VS, 118
121199, 102	121774S, 114	123084S, 123	123199VS, 118
121200S, 102	121775S, 114	123085S, 123	12326, 125
121201S, 102	121775SK, 114	123086S, 123	12327, 125
121203S, 102	121776S, 114	123087S, 123	12328, 125
121217, 106	121777S, 114	123088S, 123	12329, 125
121239S, 102	121778S, 114	123089S, 123	12331, 124
121240S, 102	121778SK, 114	123090S, 123	12332, 124
121241S, 102	121779S, 114	123091S, 123	12333, 124
121242S, 102	121965, 164, 386	123092S, 123	12334, 124
121243S, 102	121966RN, 165, 387	123094S, 123	12346S, 114
121244S, 102	121969F, 164, 386	123095S, 123	12347S, 114
121245S, 102	121969RNF, 165, 387	123096S, 123	12347SK, 114
121246S, 102	121970F, 164, 386	123097S, 123	12348S, 114
121247S, 102	121970RNF, 165, 387	123098S, 123	12349S, 114
121248S, 102	121985, 166, 388	123099S, 121	12350S, 114
121249S, 102	121987, 166, 388	123100S, 121	12350SK, 114
121250S, 102	121987RN, 166, 388	123101S, 121	12351S, 114
121251S, 102	121991, 166, 388	123102S, 121	12352S, 114
121252S, 102	122111RN, 165, 387	123103S, 121	12353S, 114
121253S, 102	122111V, 164, 386	123104S, 121	12353SK, 114
121254S, 102	122114RN, 165, 387	123105S, 121	12354S, 114
121255S, 102	122114V, 164, 386	123106S, 121	12355S, 114
121256S, 102	12284S, 110	123108S, 121	12356S, 114
121257S, 102	12285S, 110	123109S, 121	12356SK, 114
121258S, 102	12286S, 110	123110S, 121	12357S, 114
121307, 110	12287S, 110	123111S, 121	12382S, 112
121308S, 110	12288S, 110	123112S, 121	12383S, 112
121309S, 110	12289S, 110	123113S, 121	12384S, 112
121310S, 110	12290S, 110	123114S, 121	12385S, 112
121311S, 110	12291S, 110	123115S, 121	12386S, 112
121329S, 110	12292S, 110	123116S, 121	12387S, 112

Part Number Index

12388S, 112	125501VS, 116	12908, 102	14755, 342
12389S, 112	125502RIVS, 116	12910, 112	14757, 343
12390S, 112	125502VS, 116	12911, 112	14764, 342
12391S, 112	125503RIVS, 116	12912, 112	14767, 342
12392S, 112	125503VS, 116	12913, 112	14797, 343
12393S, 112	125504RIVS, 116	12914, 114	15058, 373
12394S, 112	125504VS, 116	12915, 114	15060, 373
12395S, 112	125505RIVS, 116	12916, 114	15062, 373
12396S, 112	125505VS, 116	12917, 114	15064, 373
12397S, 112	125506GV, 116	12924S, 108	15068, 373
125250GF, 122	125506RIVS, 116	12925S, 108	15070, 373
125250RS, 122	125506VS, 116	12926S, 108	15072, 373
125250S, 122	125507RIVS, 116	12927S, 108	15074, 373
125251RS, 122	125507VS, 116	12928S, 108	15076, 373
125251S, 122	125508RIVS, 116	12929S, 108	15084, 373
125252RS, 122	125508VS, 116	12930S, 108	15086, 373
125252S, 122	125509RIVS, 116	12931S, 108	15088, 373
125253RS, 122	125509VS, 116	12932S, 108	15090, 374
125253S, 122	12550S, 102	12933S, 108	15092, 374
125254GF, 122	125510GV, 116	12934S, 108	15094, 374
125254RS, 122	125510RIVS, 116	12936S, 108	15096, 374
125254S, 122	125510VS, 116	12937S, 108	15100, 374
125255RS, 122	125511RIVS, 116	12938S, 108	15102, 374
125255S, 122	125511VS, 116	12939S, 108	15335N, 373
125256RS, 122	125512RIVS, 116	12961, 108	15337N, 373
125256S, 122	125512VS, 116	12962, 108	15339N, 373
125257RS, 122	125513RIVS, 116	12963, 108	15344N, 373
125257S, 122	125513VS, 116	12964, 108	15350N, 373
125258GF, 122	12551S, 102	12967, 106	15351N, 373
125258RS, 122	125600GV, 117	12968, 106	15352N, 373
125258S, 122	125600RVS, 117	12969, 106	15354N, 372
125259RS, 122	125600VS, 117	12970V, 124	15360N, 372
125259S, 122	125601RVS, 117	12971V, 124	15361N, 372
125260RS, 122	125601VS, 117	12972V, 124	15362N, 372
125260S, 122	125602RVS, 117	131170, 231	15500, 374
125261RS, 122	125602VS, 117	13129V, 293	15507N, 372
125261S, 122	125603RVS, 117	13130V, 293	15511N, 372
125262GF, 122	125603VS, 117	13149..., 335	15703N, 372
125262RS, 122	12730, 119, 125	13150, 335	15725N, 372
125262S, 122	12745, 119, 125	13182, 329	15727N, 372
125263RS, 122	12750, 119, 125	13490A, 309	15729N, 372
125263S, 122	12763, 164, 430	13641, 291	15731N, 372
125264RS, 122	12763RNF, 165, 387	13648, 291	15732N, 372
125264S, 122	12772G, 126	13715, 239	15736N, 372
125265RS, 122	12777, 127	13716, 239	15738N, 372
125265S, 122	12778, 127	13717, 239	15826N, 372
12529S, 102	12779, 127	13718, 239	16142, 279
12530S, 102	12780, 127	13781V, 293	16152, 279
12534, 166, 432	12781L, 126	13783V, 293	16500, 278
12535RN, 165, 431	12782L, 126	13809, 325	16550, 278
12535V, 164, 430	12783, 129	13827, 371	1660..., 276
12536RN, 165, 431	12831, 164, 386	13828, 371	1665..., 276
12536V, 164, 430	12831RN, 165, 387	13833, 279	16770..., 159
12538S, 102	12833, 164, 386	13982, 239	16771..., 159
12539S, 102	12835, 164, 386	14053, 370	16772..., 159
12540S, 102	12835RN, 165, 387	14076N, 183	16773..., 159
12541S, 102	12836, 164, 386	14077N, 183	16777..., 159
12542S, 102	12836RN, 165, 387	14087N, 183	16778..., 159
12543S, 102	12837, 164, 386	14088N, 183	1680..., 277
12544S, 102	12838, 164, 386	14109, 182	1682..., 277
12545S, 102	12838RNF, 165, 387	14110..., 182	16S00020..., 156
12546S, 102	12841, 166, 388	14111, 182	16S00021..., 157
12547S, 102	12892, 164, 386	14143A, 75	16S00022..., 158
12548S, 102	12892RN, 165, 387	14144A, 75	16S00023..., 156
12549S, 102	12901, 110	14145A, 75	16S00024..., 157
125500GV, 116	12902, 110	14607, 343	16S00025..., 158
125500RIVS, 116	12903, 110	14729, 371	1700-, 119, 125
125500VS, 116	12905, 102	14734, 371	177003U, 344
125500VS, 116	12906, 102	14744N, 370	177004U, 344
125501RIVS, 116	12907, 102	14751, 342	177005U, 344

Part Number Index

177006U, 344	19082..., 238	261013, 90	32076, 107
177010U, 344	19098..., 239	261014, 90	32077B, 105
177011U, 344	19500, 222	261015, 90	32078B, 105
177053U, 344	19506, 222	261016, 90	32079B, 105
177054U, 344	19507, 222	261017, 90	32080B, 105
177055U, 344	222LSB-, 455	261018, 90	32081B, 105
177056U, 344	251800, 94	261019, 90	32082B, 105
177060U, 344	251801, 94	261102, 78	32083B, 105
177061U, 344	251802, 94	261103, 78	32084B, 105
177062U, 344	251803, 94	261104, 78	32085, 111
177104U, 344	251804, 94	261105, 78	32086, 111
177105U, 344	251805, 94	261106, 78	32086S, 111
177108U, 344	251806, 94	261107, 78	32087, 111
177109U, 344	251807, 94	261108, 78	32089, 111
177110U, 344	251808, 94	261109, 78	32090, 111
177158U, 344	251809, 94	261110, 78	32090S, 111
177159U, 344	251810, 94	261111, 78	32092, 111
177160U, 344	251811, 94	261112, 78	32099, 103
177203U, 345	251812, 94	261113, 78	32100, 103
177204U, 345	251813, 94	261114, 78	321001, 113
177205U, 345	251814, 94	261115, 78	321002, 113
177206U, 345	251815, 94	261116, 78	321003, 113
177210U, 345	251816, 94	261117, 78	321004, 113
177211U, 345	251817, 94	261118, 78	321005, 113
177254U, 345	256500, 80	261119, 78	321006, 113
177255U, 345	256501, 80	26200, 92	321007, 113
177258U, 345	256502, 80	26201, 92	321008, 113
177259U, 345	256503, 80	26202, 92	321009, 115
177260U, 345	256504, 80	26203, 92	32101, 103
177300U, 346	256505, 80	26204, 92	321010, 115
177301U, 346	256506, 80	26205, 92	321011, 115
177302U, 346	256507, 80	26206, 92	321012, 115
177303U, 346	256508, 80	26207, 92	321013, 115
177310U, 346	256509, 80	26208, 92	321014, 115
177311U, 346	256510, 80	26209, 92	321015, 115
177312U, 346	256511, 80	26210, 92	321016, 115
177313U, 346	256512, 80	26211, 92	321018, 120
177321U, 346	256513, 80	26212, 92	321019, 120
177322U, 346	256514, 80	26213, 92	32102, 103
177323U, 346	256515, 80	26214, 92	321020, 120
177350U, 347	256516, 80	26215, 92	321024, 120
177351U, 347	256517, 80	26216, 92	321025, 120
177352U, 347	26000, 88	26217, 92	321026, 120
177353U, 347	26002, 88	26218, 92	321027, 120
177360U, 347	26003, 88	26219, 92	321030, 120
177361U, 347	26004, 88	273S..., 464	321031, 120
177362U, 347	26010, 88	300..., 331	321032, 120
177363U, 347	26011, 88	32053, 103	321033, 120
19001..., 181	26012, 88	32054, 103	32104, 109
19003..., 181, 248	26014, 88	32055, 103	32105, 109
19004..., 181	26050, 76	32056, 103	32106, 109
19005..., 181	26051, 76	32057, 109	321065, 96
19006..., 180	26052, 76	32058, 109	321066, 96
19007..., 181, 248	26053, 76	32059, 109	321067, 96
190265, 276-278	26054, 76	32060, 109	32107, 109
19044SB, 222	26056, 76	32061, 107	321070, 96
19045..., 180	26057, 76	32062, 107	321071, 96
19048..., 182	26058, 76	32063, 107	321072, 96
19050..., 239	26059, 76	32064, 107	321073, 96
19052..., 240	261002, 90	32065, 103	321075, 96
19053..., 181, 240	261003, 90	32066, 103	321076, 96
19067..., 180	261004, 90	32067, 103	321077, 96
19070..., 180, 182	261005, 90	32068, 103	321078, 96
19071..., 180, 182	261006, 90	32069, 109	321080, 103
19072..., 180, 182	261007, 90	32070, 109	321081, 103
19073, 180, 182	261008, 90	32071, 109	321082, 103
19077, 276-278	261009, 90	32072, 109	321083, 103
19079, 276-278	261010, 90	32073, 107	321085, 103
19080..., 181, 240	261011, 90	32074, 107	321086, 103
19081..., 181, 240	261012, 90	32075, 107	321087, 103

Part Number Index

321088, 103	32483, 106	34211, 342	882-, 114-115
32109, 107	32484, 106	34219, 342	APS..., 392
321090, 103	32534, 166, 388	34221, 342	BPS12-, 393
321091, 103	32535, 164, 386	34763, 342	CRP-, 406, 410
321092, 103	32535RN, 165, 387	34764, 342	DPL7-, 393
321093, 103	32536, 164, 386	34768, 342	HA-, 192
321095, 109	32536RN, 165, 387	35058, 373	HAC-, 264
321096, 109	32711, 113	35060, 373	HC-, 192
321097, 109	32731, 119, 125	35062, 373	HE-, 192
321098, 109	32732, 119, 125	35064, 373	HG-, 192
32110, 107	32733, 119, 125	35066, 373	HGCP-, 193
321100, 109	32734, 119, 125	35068, 373	HL-, 407
321101, 109	32736, 119, 125	35070, 373	HP-, 407
321102, 109	32737, 119, 125	35072, 373	HPR-220, 411
321103, 109	32738, 119, 125	35074, 373	HR-, 407
321105, 109	32739, 119, 125	35076, 373	HS-, 184
321106, 109	32741, 119, 125	35078, 373	HT-, 406
321107, 109	32742, 119, 125	35082, 374	HW684WSHS, 284
321108, 109	32743, 119, 125	35084, 374	HXA-, 410
32111, 107	32744, 119, 125	35086, 374	ICD7-, 393
32112, 107	32746, 119, 125	35088, 374	ICG7-, 393
321120, 107	32747, 119, 125	35094, 374	KMD..., 147-153
321121, 107	32748, 119, 125	35098, 374	NB..., 408
32114, 115	32749, 119, 125	35100, 374	NBB-, 411
32115, 115	32751, 119, 125	35102, 374	NRB-, 412
32116, 115	32752, 119, 125	35335N, 373	NT..., 408
32117, 115	32753, 119, 125	35337N, 373	R15..., 164-165, 386-387
32119, 115	32754, 119, 125	35339N, 373	R3..., 164-165, 386-387
32120, 115	32756, 119, 125	35344N, 373	RF..., 164-166, 386-388
32121, 115	32757, 119, 125	35350N, 373	RH-, 376-379
321218, 106	32758, 119, 125	35351N, 373	RP..., 166, 388
321219, 106	32759, 119, 125	35352N, 373	SA-, 192
32122, 115	32763, 164, 386	35354N, 372	SAA-, 264
321221, 106	32763RNF, 165, 387	35360N, 372	SAB-, 264
321283, 106	32836, 164, 386	35361N, 372	SAC-, 264
321284, 106	32836RN, 165, 387	35362N, 372	SB-, 409
321285, 106	32838, 164, 386	35507N, 372	SBR-, 411
321286, 106	32838RNF, 165, 387	35511N, 372	SC-, 192
321289, 106	32866, 104	35703N, 372	SCX-, 263
321290, 106	32867, 104	35725N, 372	SCY-, 263
321966,	32868, 104	35727N, 372	SE-, 192
164, 386	32869, 104	35729N, 372	SG-, 192
321966RN,	32870, 104	35731N, 372	SPB-, 455
165, 387	32871, 104	35732N, 372	ST..., 409
321970RNF,	32872, 104	35736N, 372	STF-1006, 193
165, 387	32873, 104	35738N, 372	STM..., 155
321970F,	32874, 104	35826N, 372	VF-CR..., 171-174, 410
164, 386	32875, 104	37692, 348	VG-011-, 225-227, 236
321991,	32876, 104	37710, 349	VG-012-, 224
166, 388	32877, 104	37712, 349	VG-013-, 232
321993,	32892, 164, 386	37713, 349	VG-013-02, 219
166, 388	32892RN, 165, 387	37737, 349	VG-014H-, 234
321993RN,	33151, 331	37738, 349	VG-015..., 235
166, 388	33167, 230	37740, 349	VG-016-, 235
32400, 113	33168..., 230	38309, 348	VG-017, 235
32401, 113	33231, 309	38310, 348	VG-018..., 234
32402, 113	33262, 329	38322, 348	VG-019-12, 237
32403, 113	33298, 303	38324, 348	VG-020..., 229
32404, 113	33313, 329	38333, 348	VG-021-, 236
32405, 113	33500, 335	38334, 348	VG-022-01, 228
32406, 113	33509, 330	38336, 348	VG-031-, 227
32473, 106	33512, 330	39044, 222	VG-032-12-, 237
32474, 106	33616, 334	40009, 382	VG-040-01, 284
32475, 106	33928, 230	40018, 382	VG-113..., 232
32477, 106	33955, 279	40031, 382	VG-117-, 233, 284
32478, 106	34014, 342	815-, 102-105	VG-118..., 233
32479, 106	34018, 343	820-, 108-109	VG-1234-SERP-, 187
32480, 106	34040, 343	821-, 110	VG-1568-, 284
32481, 106	34200, 343	880-, 112-113	VG-190-, 238
32482, 106	34201, 343	881-, 106-107	VG-191-, 238

Part Number Index

VG-200-, 325	VG-615..., 337, 339	VG-GSNG-, 204	VG-P834F-, 258
VG-201-, 324	VG-616-, 338	VG-GSR-, 200	VG-PBG5-NSD-, 247
VG-202..., 294, 301	VG-617-, 336, 338	VG-GSRBG-, 194	VG-PBG7-NSD-, 247
VG-203..., 292-293, 301	VG-618-, 336, 338	VG-GST-, 176, 178, 202, 204, 213	VG-PBWS-125-10, 188
VG-204..., 228, 324-325	VG-619-, 330, 338	VG-GSTG-, 178, 204	VG-PCR-25100-, 187
VG-205-, 321-322	VG-620-, 330	VG-GSVBG-, 194	VG-PM10BC-, 245
VG-205-G-14-S, 283	VG-621..., 328	VG-GSWF-, 200	VG-PM6BC-, 244
VG-210..., 294, 301	VG-623-, 331	VG-J..., 248-251	VG-PMBG-50-, 188
VG-211..., 317-319	VG-627..., 332	VG-LDA-100..., 217	VG-PMI-, 215
VG-212..., 227, 296-297, 303	VG-628-, 333	VG-LDNP-, 216	VG-PSBG-50-10, 188
VG-213..., 310-312, 315-316	VG-629..., 333	VG-LDP-100-, 217	VG-Q-, 320
VG-215-, 336	VG-630-BK, 380	VG-LDSP-, 216	VG-QPC-, 300
VG-221..., 291, 301	VG-631-14..., 380	VG-MBG-50-, 188	VG-QSB..., 300
VG-223..., 312-316	VG-632-516, 380	VG-NG..., 246	VG-QSC..., 300
VG-232, 296-297	VG-633..., 381	VG-P0808-, 258	VG-QT-01, 300
VG-238-, 365	VG-634-, 381	VG-P1010RBC-, 254	VG-RCBT-, 51, 53
VG-245-, 304-305	VG-635-, 381	VG-P1012-, 195	VG-RS-, 220-221
VG-252-4-38, 227	VG-641..., 323	VG-P104D-, 242	VGRU-, 196
VG-253..., 308-309	VG-650..., 187	VG-P105..., 242, 246	VG-S12HR-, 253
VG-254..., 308-309	VG-681-, 283	VG-P116..., 242	VG-S12ROD-, 237
VG-280..., 307	VG-682-, 282	VG-P125125BC-, 254	VG-S34HR-, 253
VG-281-M10F, 307	VG-684..., 275, 280	VG-P12BC-, 245	VG-S5015-, 261
VG-282..., 307	VG-685-, 281	VG-P12HR-, 253	VG-S58HR-, 253
VG-290, 306	VG-686..., 274, 285	VG-P12RD-, 252	VG-SBG-50-10, 188
VG-291, 306	VG-687..., 269-271, 284-285	VG-P12RDBAR-, 262	VG-SC..., 340
VG-292, 306	VG-688..., 272-273	VG-P1345-, 243	VG-SCAP-, 295
VG-305..., 370	VG-690, 220	VG-P14..., 244	VG-SE-582-, 165, 387
VG-307..., 369	VG-691..., 220-221	VG-P1515BC-, 254	VG-SPM-, 214
VG-308-, 369	VG-692, 220-221	VG-P1520..., 254	VG-SSCG-, 191, 206
VG-311-, 371	VG-693..., 220	VG-P18..., 242	VG-SSCT-, 194
VG-340-, 189-190	VG-694..., 220	VG-P1878BC-, 255, 259	VG-SSECG-, 191, 207
VG-360-, 190	VG-695, 220	VG-P18CC-, 248	VG-SSF-, 191, 200-201, 206, 212-213
VG-370..., 189	VG-696, 221	VG-P1910BC-, 255	VG-SSFS-, 208-209
VG-380-, 190	VG-697..., 220	VG-P1x1BC-, 254	VG-SSLD-, 216
VG-450, 375	VG-698..., 221	VG-P2007-, 257	VG-SSLT-, 176-177, 204-205
VG-452, 375	VG-699-, 221	VG-P204-, 242	VG-SSLTs-, 176-177, 210-211
VG-501..., 353, 363, 365	VG-710-U..., 186	VG-P2115BC-, 256	VG-SSM-, 200-201
VG-504, 363	VG-730-, 219	VG-P251..., 255-256	VG-SSMS-, 208-209
VG-505..., 354, 364	VG-750-, 185	VG-P2520..., 256, 259	VG-SSMT-, 200-201
VG-506, 363	VG-761-10, 219	VG-P2x2BC-10, 254	VG-SSNG-, 204-205
VG-511..., 355-358, 365	VG-770-, 326	VG-P316..., 243	VG-SSR-, 200-201, 212
VG-512, 363	VG-771-, 326	VG-P34HR-, 253	VG-SSRBG-, 194
VG-513..., 359, 365	VG-A1000-, 195, 257	VG-P34HRL-, 253	VG-SSRS-, 208-209
VG-514..., 363	VG-A1315-, 195	VG-P34RD-, 252	VG-SST-, 176-179, 202-205, 213
VG-516, 363	VG-A1878..., 259	VG-P350-, 260	VG-SSTG-, 178-179, 204-205
VG-517-01-, 361	VG-A225-, 258	VG-P37..., 190	VG-SSTS-, 176-177, 210-211
VG-518..., 360	VG-A2520-, 259	VG-P38BC-, 245	VG-SSUT-, 188
VG-520-, 361-362	VG-A275-, 258	VG-P38HD-, 245	VG-SSVBG-, 194
VG-525-02-, 364	VG-A350-, 260	VG-P38RD-, 252	VG-SSWF-, 200-201
VG-533-01-, 352	VG-A500-, 195, 257	VG-P38RDBAR-, 262	VG-SSWFS-, 208-209
VG-534, 363	VG-A5015-, 260	VG-P3920BC-, 256	VG-T-, 196
VG-537-01-, 352	VG-A5020-, 260	VG-P417CT-10, 252	VG-VSR, 306
VG-538, 363	VG-A600-, 258	VG-P5010BC-, 254	VRE-640-1540-, 412
VG-550-, 342	VG-A900-, 258	VG-P5015..., 256, 260-261	VT-, 131-134
VG-551-, 342	VG-ABG..., 247	VG-P5020BC-, 256, 260	VT2-, 136
VG-552-, 343	VG-ARB-, 385	VG-P512..., 257	VT2K-, 144
VG-553-, 343	VG-ASRB-, 385	VG-P516BC-, 245	VT3-, 137
VG-554-, 342	VG-BWS-125-10, 188	VG-P516RD-, 252	VT3K-, 145
VG-555-, 343	VG-C115, 370	VG-P58115BC-, 254	VTK-, 140-142
VG-556-, 343	VG-CS..., 193	VG-P58HR-, 253	
VG-558-, 342	VG-CSI-538-, 242	VG-P58RD-, 252	
VG-560-, 343	VG-CTOP-, 295	VG-P611-, 258	
VG-561-, 343	VG-G5015-, 261	VG-P710-, 195	
VG-580-, 368	VG-GSCG-, 191, 206	VG-P7701-10, 252	
VG-592..., 367-368	VG-GSCT-, 194	VG-P7GA..., 243	
VG-594..., 367	VG-GSECG-, 191, 207	VG-P813..., 258	
VG-596..., 367-368	VG-GSF, 191, 200, 206, 213	VG-P816F-, 258	
VG-598..., 367-368	VG-GSLT-, 176, 204	VG-P820F-, 258	
VG-612-, 228, 331	VG-GSM-, 200	VG-P822F-, 258	
VG-614-, 336, 338	VG-GSMT-, 200	VG-P824F-, 258	

All sales are made on our STANDARD TERMS AND CONDITIONS OF SALE in effect at the time a customer's order is accepted. The current Terms and Conditions are set forth below:

STANDARD TERMS AND CONDITIONS OF SALE (February 2015)

These Terms and Conditions, the attendant quotation or acknowledgment and all documents incorporated by specific reference therein, will be the complete and exclusive statement of the terms of the agreement governing the sale of goods ("Goods") by Regal Beloit America Inc. and its divisions and subsidiaries ("Seller") to Customer ("Buyer"). Buyer's acceptance of the Goods will manifest Buyer's assent to these Terms and Conditions. If these Terms and Conditions differ in any way from the terms and conditions of Buyer's order, or other documentation, this document will be construed as a counteroffer and will not be deemed an acceptance of Buyer's terms and conditions which conflict herewith.

1. **PRICES:** Unless otherwise specified in writing by Seller, Seller's price for the goods shall remain in effect for thirty (30) days after the date of Seller's quotation or acknowledgment of Buyer's order for the Goods, whichever occurs first, provided an unconditional, complete authorization for the immediate shipment of the Goods is received and accepted by Seller within such time period. If such authorization is not received by Seller within such thirty (30) day period, Seller shall have the right to change the price for the Good to Seller's price for the Goods at the time of shipment.

2. **TAXES:** Any tax or governmental charge or increase in same hereafter becoming effective increasing the cost to Seller of producing, selling or delivering the Goods/provision of Services or of procuring material used therein, and any tax now in effect or increase in same payable by the Seller because of the manufacture, sale or delivery of the Goods/provision of Services, may at Seller's option, be added to the price.

3. **TERMS OF PAYMENT:** Subject to the approval of Seller's Credit Department, terms are net thirty (30) days from date of Seller's invoice in U.S. currency. If any payment owed to Seller is not paid when due, it shall bear interest, at a rate to be determined by Seller, which shall not exceed the maximum rate permitted by law, from the date on which it is due until it is paid. Seller shall have the right, among other remedies, either to terminate the Agreement or to suspend further performance under this and/or other agreements with Buyer in the event Buyer fails to make any payment when due. Buyer shall be liable for all expenses, including attorneys' fees, relating to the collection of past due amounts.

4. **SHIPMENT AND DELIVERY:** Shipments are made F.O.B. Seller's shipping point. Any claims for shortages or damages suffered in transit shall be submitted by the Buyer directly to the carrier. While Seller will use all reasonable commercial efforts to maintain the delivery date for the Goods or the date of provision of Services acknowledged or quoted by Seller, all such dates are approximate. Seller reserves the right to make partial shipments and to segregate "specials" and made-to-order Goods from normal stock Goods. Seller shall not be bound to tender delivery of any Goods for which Buyer has not provided shipping instructions.

5. **QUANTITY:** Buyer agrees to accept overruns of up to ten percent (10%) of the order on "made-to-order" Goods, including parts. Any such additional items shall be priced at the price per item charged for the specific quantity ordered.

6. **LIMITED WARRANTY:** Subject to the limitations of Section 7, Seller warrants that the Goods will be free from defects in material and workmanship under normal use, service and maintenance and Services will be performed by trained personnel using proper equipment and instrumentation for the particular Service provided. Any licensed firmware embodied in the Goods will execute the programming instructions provided by Seller. The foregoing warranties will apply until the expiration of the applicable warranty period. Except as specified below, Goods are warranted for twelve (12) months (unless otherwise specified by Seller in writing) from the date of shipment of the Goods by Seller. Consumables and Services (except as specified below) are warranted for a period of 90 days from the date of shipment or completion of the Services. Products purchased by Seller from a third party for resale to Buyer ("Resale Products") shall carry only the warranty extended by the original manufacturer. Buyer agrees that Seller has no liability for Resale Products beyond making a reasonable commercial effort to arrange for procurement and shipping of the Resale Products. **THIS IS THE SOLE AND EXCLUSIVE WARRANTY GIVEN BY SELLER WITH RESPECT TO THE GOODS/SERVICES AND IS IN LIEU OF AND EXCLUDES ALL OTHER WARRANTIES, EXPRESS OR IMPLIED, ARISING BY OPERATION OF LAW OR OTHERWISE, INCLUDING WITHOUT LIMITATION, MERCHANTABILITY OR FITNESS FOR A PARTICULAR PURPOSE WHETHER OR NOT THE PURPOSE OR USE HAS BEEN DISCLOSED TO SELLER IN SPECIFICATIONS, DRAWINGS OR OTHERWISE, AND WHETHER OR NOT SELLER'S PRODUCTS ARE SPECIFICALLY DESIGNED AND/OR MANUFACTURED BY SELLER FOR BUYER'S USE OR PURPOSE.**

This warranty does not extend to any losses or damages due to misuse, accident, abuse, neglect, normal wear and tear, unauthorized modification or alteration, use beyond rated capacity, or improper installation, maintenance or application. To the extent that Buyer or its agents has supplied specifications, information, representation of operating conditions or other data to Seller in the selection or design of the Goods or provision of Services and the preparation of Seller's quotation, and in the event that actual operating conditions or other conditions differ from those represented by Buyer, any warranties or other provisions contained herein which are affected by such conditions shall be null and void. If within thirty (30) days after Buyer's discovery of any warranty defects within the warranty period, Buyer notifies Seller thereof in writing, Seller shall, at its option, repair, correct, or replace F.O.B. point of manufacture, or refund the purchase price for, that portion of the goods found by Seller to be defective. Failure by Buyer to give such written notice within the applicable time period shall be deemed an absolute and unconditional waiver of Buyer's claim for such defects. Goods repaired or replaced during the warranty period shall be covered by the foregoing warranty for the remainder of the original warranty period or ninety (90) days, whichever is longer. Buyer assumes all other responsibility for any loss, damage, or injury to persons or property arising out of, connected with, or resulting from the use of Goods, either alone or in combination with other products/components.

SECTIONS 6 AND 7 APPLY TO ANY ENTITY OR PERSON WHO MAY BUY, ACQUIRE OR USE SELLER'S GOODS, INCLUDING ANY ENTITY OR PERSON WHO BUYS THE GOODS FROM SELLER'S DISTRIBUTOR AND SUCH ENTITY OR PERSON SHALL BE BOUND BY THE LIMITATIONS THEREIN.

7. **LIMITATION OF REMEDY AND LIABILITY: THE SOLE AND EXCLUSIVE REMEDY FOR BREACH OF ANY WARRANTY HEREUNDER (OTHER THAN THE WARRANTY PROVIDED UNDER SECTION 13) SHALL BE LIMITED TO REPAIR, CORRECTION, REPLACEMENT, OR REFUND OF THE PURCHASE PRICE UNDER SECTION 6. SELLER SHALL NOT BE LIABLE FOR DAMAGES CAUSED BY DELAY IN PERFORMANCE AND IN NO EVENT, REGARDLESS OF THE FORM OF THE CLAIM OR CAUSE OF ACTION (WHETHER BASED IN CONTRACT, INFRINGEMENT, NEGLIGENCE, STRICT LIABILITY, OTHER TORT OR OTHERWISE), SHALL SELLER'S LIABILITY TO BUYER AND/OR ITS CUSTOMERS EXCEED THE PRICE TO BUYER OF THE SPECIFIC GOODS OR SERVICES PROVIDED BY SELLER GIVING RISE TO THE CLAIM OR CAUSE OF ACTION. BUYER AGREES THAT IN NO EVENT SHALL SELLER'S LIABILITY TO BUYER AND/OR ITS CUSTOMERS EXTEND TO INCLUDE INCIDENTAL, CONSEQUENTIAL OR PUNITIVE DAMAGES. THE TERM "CONSEQUENTIAL DAMAGES" SHALL INCLUDE, BUT NOT BE LIMITED TO, LOSS OF ANTICIPATED PROFITS, LOSS OF USE, LOSS OF REVENUE, COST OF CAPITAL AND DAMAGE OR LOSS OF OTHER PROPERTY OR EQUIPMENT AND COSTS INCURRED INCLUDING WITHOUT LIMITATION FOR CAPITAL, FUEL AND POWER, AND CLAIMS OF BUYER'S CUSTOMERS. GOODS AND/OR SERVICES SOLD HEREUNDER ARE NOT FOR USE IN ANY NUCLEAR AND RELATED APPLICATIONS.** Buyer accepts goods and/or services with the foregoing understanding, agrees to communicate the same in writing to any subsequent purchaser or users and to defend, indemnify and hold harmless Seller from any claims, losses, suits, judgments and damages, including incidental and consequential damages, arising from such use, whether the cause of action be based in tort, contract or otherwise, including allegations that the Seller's liability is based on negligence or strict liability.

8. **BUYER RESPONSIBILITIES:** Buyer shall provide Seller ready access to the site where services are to be performed and adequate workspace and facilities to perform same as provided in these terms and conditions. Buyer shall not require Seller or its employees, as a condition to site access or otherwise, to further agree or enter into any agreement, which waives, releases, indemnifies or otherwise limits or expands any rights or obligations whatsoever. Any such agreements shall be null and void. Buyer shall inform Seller, in writing, at the time of order placement, of any known hazardous substance or condition at the site, including, but not limited to, the presence of asbestos or asbestos containing materials, and shall provide Seller with any applicable Material Data Safety Sheets regarding same. Buyer shall appoint a representative familiar with the site and the nature of the services to be performed by Seller to be present at all times that Seller personnel are at the site. Seller shall not be liable for any expenses incurred

by Buyer in removing, replacing or refurbishing any Buyer equipment or any part of Buyer's building structure that restricts Seller access. Buyer personnel shall cooperate with and provide all necessary assistance to Seller. Seller shall not be liable or responsible for any work performed by Buyer.

9. **BUYER SUPPLIED DATA:** To the extent that Seller has relied upon any data or information supplied by Buyer to Seller ("Data") in the selection or design of the Goods and/or provision of the Services and the preparation of Seller's quotation, and the Data is inadequate or inaccurate, any warranties or other provisions contained herein which are affected by such conditions shall be null and void.

10. **TECHNICAL ADVICE:** It is expressly understood that the Seller assumes no obligation or liability for any technical advice given without charge and furnished by the Seller with respect to the use of the Goods. All such technical advice, or results obtained, is given and accepted at Buyer's risk.

11. **EXCUSE OF PERFORMANCE:** Seller shall not be liable for delays in performance or for non-performance due to acts of God, acts of Buyer, war, riot, fire, flood, other severe weather, sabotage, or epidemics; strikes or labor disturbances; governmental requests, restrictions, laws, regulations, orders or actions; unavailability of or delays in transportation; default of suppliers; or unforeseen circumstances or any events or causes beyond Seller's reasonable control. Deliveries of Goods or provision of Services may be suspended for an appropriate period of time as a result of the foregoing. If Seller determines that its ability to supply the total demand for the Goods, or to obtain material used directly or indirectly in the manufacture of the Goods, is hindered, limited or made impracticable due to causes addressed in this Section 8, Seller may allocate its available supply of the Goods or such material (without obligation to acquire other supplies of any such Goods or material) among itself and its purchasers on such basis as Seller determines to be equitable without liability for any failure of performance which may result therefrom. Deliveries suspended or not made by reason of this section may be canceled by Seller upon notice to Buyer without liability, but the balance of the agreement shall otherwise remain unaffected.

12. **CANCELLATIONS AND DELAYS:** The Buyer may cancel orders only upon written notice and upon payment to Seller of cancellation charges which include, among other things, all costs and expenses incurred and commitments made by the Seller and a reasonable profit thereon. Any request by Buyer to extend the delivery schedule must be agreed to in writing by the Seller. If agreement cannot be reached, Seller may deliver product or provide services to the last known ship to address and invoice the Buyer upon completion of the product or services or prior delivery date, whichever is later.

13. **CHANGES:** Buyer may request changes or additions to the Goods/Services consistent with Seller's specifications and criteria. In the event such changes or additions are accepted by Seller, Seller may revise the price and delivery schedule. Seller reserves the right to change designs and specifications for the Goods or Services without prior notice to Buyer, except with respect to Goods being made-to-order for Buyer. Seller may cancel any order or terminate any agreement without liability to Buyer if Buyer fails to meet the conditions specified herein.

14. **TOOLING:** Tool, die, and pattern charges, if any, are in addition to the price of the Goods/Services and are due and payable upon completion of the tooling. All such tools, dies and patterns shall be and remain the property of Seller. Charges for tools, dies, and patterns do not convey to Buyer, title, ownership interests in, or rights to possession or removal, nor prevent their use by Seller for other purchasers, except as otherwise expressly provided by Seller and Buyer in writing with reference to this provision.

15. **SOFTWARE AND FIRMWARE:** Notwithstanding any other provision herein to the contrary, Seller or applicable third party owner shall retain all rights of ownership and title in its respective firmware and software, including all copyrights relating to such firmware and software and all copies of such firmware and software. Except as otherwise provided herein, Buyer is hereby granted a nonexclusive, royalty free license to use firmware and software, and copies of firmware and software, incorporated into the Goods only in conjunction with such Goods and only at the Buyer's plant site where the Goods are first used. Buyer's use of certain firmware (as specified by Seller) and all other software shall be governed exclusively by Seller's and/or third party owner's applicable license terms.

16. **ASSIGNMENT:** Buyer shall not assign its rights or delegate its duties hereunder or any interest therein or any rights hereunder without the prior written consent of the Seller, and any such assignment, without such consent, shall be void.

17. **PATENTS AND COPYRIGHTS:** Subject to Section 7, Seller warrants that the Goods and/or Services sold, except as are made specifically for Buyer according to Buyer's specifications, do not infringe any valid U.S. patent or copyright in existence as of the date of delivery. This warranty is given upon the condition that Buyer promptly notify Seller of any claim or suit involving Buyer in which such infringement is alleged, and, that Buyer cooperate fully with Seller and permit Seller to control completely the defense or compromise of any such allegation of infringement. Seller's warranty as to use only applies to infringements arising solely out of the inherent operation (i) of such Goods, or (ii) of any combination of Goods in a system designed by Seller. In the event such Goods and/or Services, singularly or in combination, are held to infringe a U.S. patent or copyright in such suit, and the use of such Goods and/or Services is enjoined, or in the case of a compromise by Seller, Seller shall have the right, at its option and expense, to procure for Buyer the right to continue using such Goods or providing such Services, or replace them with non-infringing Goods or Services; or modify same to become non-infringing; or grant Buyer a credit for the depreciated value of such Goods and accept return of them or grant Buyer a credit for such provided Services.

18. **EXPORT/IMPORT:** Buyer agrees that all applicable import and export control laws, regulations, orders, and requirements, including without limitation those of the United States and the European Union, and the jurisdictions in which the Seller and the Buyer are established or from which Goods may be supplied, will apply to their receipt and use. In no event shall Buyer use, transfer, release, import, or export Goods in violation of such applicable laws, regulations, orders or requirements.

19. **HIRING/EMPLOYEES:** Buyer agrees that during the execution of Services by Seller and for a period of twelve (12) months after the performance of Services, it will not hire any employee(s) of Seller and will not entice or counsel any such employee(s) to leave Seller's employ. Buyer agrees that this covenant shall extend to its agents and affiliates. In the event that an employee of Seller is hired or leaves the employ of Seller in such circumstances, Buyer shall pay Seller, as compensation for the cost incurred by Seller in recruiting and training the employee, the sum equivalent to six (6) months pay for each employee hired from or leaving the employment of Seller.

20. **EMPLOYEE SAFETY AND SUSPENSION OF SERVICES:** Seller may suspend or terminate Services, at its sole discretion, without liability to Buyer if Buyer fails to meet its obligations hereunder or becomes bankrupt or insolvent or if Seller determines that continuing to provide Services represents a hazardous condition for its employees.

21. **MISCELLANEOUS:** These terms and conditions set forth the entire understanding and agreement between Seller and Buyer, and supersede all other communications, negotiations and prior oral or written statements regarding the subject matter of these terms and conditions. No change, modification, rescission, discharge, abandonment, or waiver of these terms and conditions of Sale shall be binding upon the Seller unless made in writing and signed on its behalf by an officer of the Seller. No conditions, usage or trade, course of dealing or performance, understanding or agreement purporting to modify, vary, explain, or supplement these Terms and Conditions shall be binding unless hereafter made in writing and signed by the party to be bound, and no modification shall be affected by the acceptance of purchase orders or shipping instruction forms containing terms at variance with or in addition to those set forth herein. Any such modifications or additional terms are specifically rejected by Seller. No waiver by Seller with respect to any breach or default or any right or remedy and no course of dealing, shall be deemed to constitute a continuing waiver of any other breach or default or of any other right or remedy, unless such waiver be expressed in writing and signed by the party to be bound. Seller is not responsible for typographical or clerical errors made in any quotation, orders or publications. All such errors are subject to correction. The validity, performance, and all other matters relating to the interpretation and effect of this contract shall be governed by the law of the state of New York. The United Nations Convention on the International Sale of Goods shall not apply to any transaction hereunder.

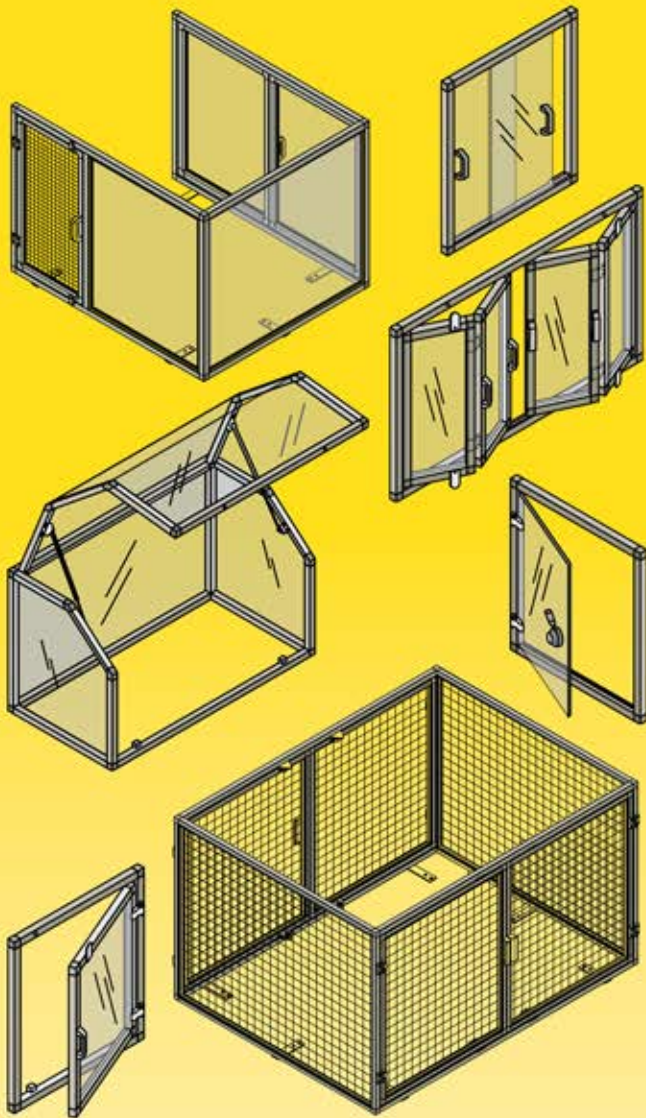

Guarding Products from ValuGuard™ Improve the Safety and Appearance of Your Machinery!

Protective enclosures keep material contained within the machine area, and prevent people or items from accidentally entering the operating machine's space. When properly constructed, the guards enhance the appearance of OEM equipment.

The product line is based on the concept that with a pre-engineered system of components, custom structures can be made faster, more attractive and more economically than by welding or other traditional fabrication methods.

These framing systems from System Plast™ can extend their versatility to almost any industry. Build shelves, counters, displays, cubicles, or even entire freestanding rooms. With a full line of accessories, the possibilities are only limited by your imagination.

For more information, please contact one of our helpful Customer Service Representatives.

**Accelerating Production
Through Innovation**

866-765-8744
www.RegalPTS.com

VALU TM
GUARD

SYSTEM PLAST™

Regal Power Transmission Solutions
7120 New Buffington Rd
Florence, KY 41042
Customer Service: 866-765-8744
Fax: 866-447-6587
Technical Service: 800-626-2093

www.RegalPTS.com
www.SystemPlastSmartGuide.com

APPLICATION CONSIDERATIONS

The proper selection and application of power transmission products and components, including the related area of product safety, is the responsibility of the customer. Operating and performance requirements and potential associated issues will vary appreciably depending upon the use and application of such products and components. The scope of the technical and application information included in this publication is necessarily limited. Unusual operating environments and conditions, lubrication requirements, loading supports, and other factors can materially affect the application and operating results of the products and components and the customer should carefully review its requirements. Any technical advice or review furnished by Regal-Beloit America, Inc. and its affiliates with respect to the use of products and components is given in good faith and without charge, and Regal assumes no obligation or liability for the advice given, or results obtained, all such advice and review being given and accepted at customer's risk.

For a copy of our Standard Terms and Conditions of Sale, Disclaimers of Warranty, Limitation of Liability and Remedy, please contact Customer Service at 1-800-626-2120. These terms and conditions of sale, disclaimers and limitations of liability apply to any person who may buy, acquire or use a Regal-Beloit America Inc. product referred to herein, including any person who buys from a licensed distributor of these branded products. Regal, New Generation, NG, Nolu, System Plast and Vulu Guide are trademarks of Regal-Beloit Corporation or one of its affiliated companies.

©2015 Regal-Beloit Corporation. All Rights Reserved. MCC15001E • Form# 9228E • Printed in USA

A Regal Brand



REGAL

www.regalbeloit.com